

(19) World Intellectual Property Organization  
International Bureau



(43) International Publication Date  
4 December 2003 (04.12.2003)

PCT

(10) International Publication Number  
WO 03/100141 A1

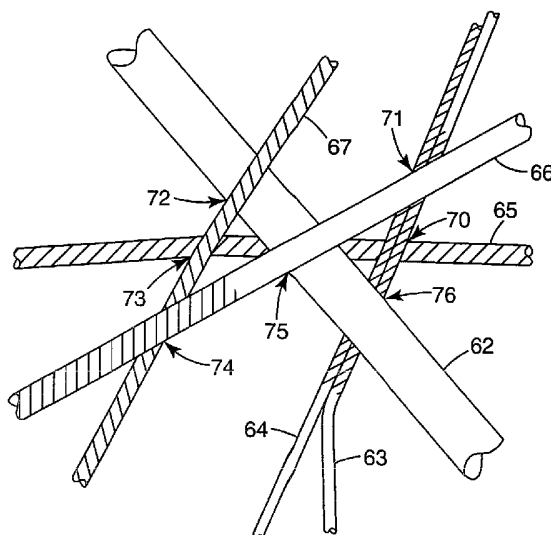
- (51) International Patent Classification<sup>7</sup>: D01D 5/098, D04H 3/03, 3/16
- (21) International Application Number: PCT/US03/11566
- (22) International Filing Date: 16 April 2003 (16.04.2003)
- (25) Filing Language: English
- (26) Publication Language: English
- (30) Priority Data:  
10/151,782 20 May 2002 (20.05.2002) US
- (71) Applicant: 3M INNOVATIVE PROPERTIES COMPANY [US/US]; 3M Center, Post Office Box 33427, Saint Paul, MN 55133-3427 (US).
- (72) Inventors: BERRIGAN, Michael, R.; Post Office Box 33427, Saint Paul, MN 55133-3427 (US). DE ROVERE, Anne, N.; Post Office Box 33247, Saint Paul, MN 55133-3427 (US). FAY, William, T.; Post Office Box 33427, Saint Paul, MN 55133-3427 (US). MUNRO, Jill, R.; Post Office Box 33427, Saint Paul, MN 55133-3427 (US). PERCHA, Pamela, A.; Post Office Box 33427, Saint Paul, MN 55133-3427 (US).
- (74) Agents: TAMTE, Roger, R. et al.; Post Office Box 33427, Saint Paul, MN 55133-3427 (US).
- (81) Designated States (*national*): AE, AG, AL, AM, AT (utility model), AT, AU, AZ, BA, BB, BG, BR, BY, BZ, CA, CH, CN, CO, CR, CU, CZ (utility model), CZ, DE (utility model), DE, DK (utility model), DK, DM, DZ, EC, EE (utility model), EE, ES, FI (utility model), FI, GB, GD, GE, GH, GM, HR, HU, ID, IL, IN, IS, JP, KE, KG, KP, KR, KZ, LC, LK, LR, LS, LT, LU, LV, MA, MD, MG, MK, MN, MW, MX, MZ, NI, NO, NZ, OM, PH, PL, PT, RO, RU, SC, SD, SE, SG, SK (utility model), SK, SL, TJ, TM, TN, TR, TT, TZ, UA, UG, UZ, VC, VN, YU, ZA, ZM, ZW.
- (84) Designated States (*regional*): ARIPO patent (GH, GM, KE, LS, MW, MZ, SD, SL, SZ, TZ, UG, ZM, ZW), Eurasian patent (AM, AZ, BY, KG, KZ, MD, RU, TJ, TM), European patent (AT, BE, BG, CH, CY, CZ, DE, DK, EE, ES, FI, FR, GB, GR, HU, IE, IT, LU, MC, NL, PT, SE, SI, SK, TR), OAPI patent (BF, BJ, CF, CG, CI, CM, GA, GN, GQ, GW, ML, MR, NE, SN, TD, TG).

**Declarations under Rule 4.17:**

— as to applicant's entitlement to apply for and be granted a patent (Rule 4.17(ii)) for the following designations AE, AG, AL, AM, AT, AU, AZ, BA, BB, BG, BR, BY, BZ, CA,

[Continued on next page]

(54) Title: BONDABLE, ORIENTED, NONWOVEN FIBROUS WEBS AND METHODS FOR MAKING THEM



(57) Abstract: Nonwoven fibrous webs comprise fibers of uniform diameter that vary in morphology along their length. The variation provides longitudinal segments that exhibit distinctive softening characteristics during a bonding operation. Some segments soften under the conditions of the bonding operation and bond to other fibers of the web, and other segments are passive during the bonding operation. Webs as described can be formed by a method that comprises a) extruding filaments of fiber-forming material; b) directing the filaments through a processing chamber in which the filaments are subjected to longitudinal stress; c) subjecting the filaments to turbulent flow conditions after they exit the processing chamber; and d) collecting the processed filaments; the temperature of the filaments being controlled so that at least some of the filaments solidify while in the turbulent field.



WO 03/100141 A1



CH, CN, CO, CR, CU, CZ, DE, DK, DM, DZ, EC, EE, ES, FI, GB, GD, GE, GH, GM, HR, HU, ID, IL, IN, IS, JP, KE, KG, KP, KR, KZ, LC, LK, LR, LS, LT, LU, LV, MA, MD, MG, MK, MN, MW, MX, MZ, NI, NO, NZ, OM, PH, PL, PT, RO, RU, SC, SD, SE, SG, SK, SL, TJ, TM, TN, TR, TT, TZ, UA, UG, UZ, VC, VN, YU, ZA, ZM, ZW, ARIPO patent (GH, GM, KE, LS, MW, MZ, SD, SL, SZ, TZ, UG, ZM, ZW), Eurasian patent (AM, AZ, BY, KG, KZ, MD, RU, TJ, TM), European patent (AT, BE, BG, CH, CY, CZ, DE, DK, EE,

ES, FI, FR, GB, GR, HU, IE, IT, LU, MC, NL, PT, SE, SI, SK, TR), OAPI patent (BF, BJ, CF, CG, CI, CM, GA, GN, GQ, GW, ML, MR, NE, SN, TD, TG)

- as to the applicant's entitlement to claim the priority of the earlier application (Rule 4.17(iii)) for all designations

**Published:**

- with international search report

For two-letter codes and other abbreviations, refer to the "Guidance Notes on Codes and Abbreviations" appearing at the beginning of each regular issue of the PCT Gazette.

## **BONDABLE, ORIENTED, NONWOVEN FIBROUS WEBS AND METHODS FOR MAKING THEM**

Bonding of oriented-fiber nonwoven fibrous webs often requires an undesirable  
5 compromise in processing steps or product features. For example, when collected webs of  
oriented fibers such as meltspun or spunbond fibers are bonded (e.g., to consolidate the  
web, increase its strength, or otherwise modify web properties), a bonding fiber or other  
bonding material is typically included in the webs in addition to the meltspun or spunbond  
fibers. Alternatively or in addition, the web is subjected to heat and pressure in a point-  
10 bonding or area-wide calendering operation. Such steps are required because the meltspun  
or spunbond fibers themselves generally are highly drawn to increase fiber strength,  
leaving the fibers with limited capacity to participate in fiber bonding.

But addition of bonding fibers or other bonding material increases the cost of the  
web, makes the manufacturing operation more complex, and introduces extraneous  
15 ingredients into the webs. And heat and pressure changes the properties of the web, e.g.,  
making the web more paperlike, stiff, or brittle.

Bonding between spunbond fibers, even when obtained with the heat and pressure  
of point-bonding or calendering, also tends to be of lower strength than desired: the bond  
strength between spunbond fibers is typically less than the bond strength between fibers  
20 that have a less-ordered morphology than spunbond fibers have; see the recent publication,  
*Structure and properties of polypropylene fibers during thermal bonding*, Subhash Chand  
et al, (Thermochimica Acta 367-368 (2001) 155-160).

While the art has recognized the deficiencies involved in bonding of oriented-fiber  
webs, no satisfactory solution is known to exist. U.S. Patent No. 3,322,607 describes one  
25 effort at improvement, suggesting among other bonding techniques that fibers be prepared  
having mixed-orientation fibers, in which some segments of the fibers have a lower  
orientation and thereby a lower softening temperature such that they function as binder  
filaments. As illustrated in Example XII of this patent (see also column 8, lines 9-52),  
such mixed-orientation fibers are prepared by leading extruded filaments to a heated feed  
30 roll and engaging the filaments on the roll for some time while the roll rotates. Low-  
orientation segments are said to result from such contact and to provide bondability in the

webs. (See also U.S. Patent No. 4,086,381, for example, at column 5, line 59 et seq, for a similar teaching.)

5 But the low-orientation bonding segments of the fibers in U.S. Patent No. 3,322,607 are also of greater diameter than other segments of higher orientation (col. 17, ll. 21-25). The result is that increased heat is needed to soften the low-orientation segments to bond the web. Also, the whole fiber-forming process is operated at a rather low speed, thereby decreasing efficiency. And according to the patent (col. 8, ll. 22-25 and 60-63) the bonding of the low-orientation segments is apparently insufficient for adequate bonding, with the result that bonding conditions are selected to provide some  
10 bonding of the high-orientation segments or fibers in addition to the low-orientation segments.

Improved bonding methods are needed, and it would be desirable if these methods could provide autogenous bonding (defined herein as bonding between fibers at an elevated temperature as obtained in an oven or with a through-air bonder – also known as  
15 a hot-air knife -- without application of solid contact pressure such as in point-bonding or calendering), and preferably with no added binding fiber or other bonding material. The high level of drawing of meltspun or spunbond fibers limits their capacity for autogenous bonding. Instead of autogenous bonding, most single-component meltspun or spunbond fibrous webs are bonded by use of heat and pressure, e.g., point-bonding or a more area-  
20 wide application of heat and calendering pressure; and even the heat-and-pressure processes are typically accompanied by use of bonding fibers or other bonding material in the web.

The present invention provides new nonwoven fibrous webs that exhibit many desired physical properties of oriented-fiber webs such as spunbond webs, but have  
25 improved and more convenient bondability. Briefly summarized, a new web of the invention comprises fibers of uniform diameter that vary in morphology over their length so as to provide longitudinal segments that differ from one another in softening characteristics during a selected bonding operation. Some of these longitudinal segments soften under the conditions of the bonding operation, i.e., are active during the selected  
30 bonding operation and become bonded to other fibers of the web; and others of the segments are passive during the bonding operation. By “uniform diameter” it is meant that the fibers have essentially the same diameter (varying by 10 percent or less) over a

significant length (i.e., 5 centimeters or more) within which there can be and typically is variation in morphology. Preferably, the active longitudinal segments soften sufficiently under useful bonding conditions, e.g., at a temperature low enough, that the web can be autogenously bonded.

5           The fibers are preferably oriented; i.e., the fibers preferably comprise molecules that are aligned lengthwise of the fibers and are locked into (i.e., are thermally trapped into) that alignment. In preferred embodiments, the passive longitudinal segments of the fibers are oriented to a degree exhibited by typical spunbond fibrous webs. In crystalline or semicrystalline polymers, such segments preferably exhibit strain-induced or chain-  
10           extended crystallization (i.e., molecular chains within the fiber have a crystalline order aligned generally along the fiber axis). As a whole, the web can exhibit strength properties like those obtained in spunbond webs, while being strongly bondable in ways that a typical spunbond web cannot be bonded. And autogenously bonded webs of the invention can have a loft and uniformity through the web that are not available with the  
15           point-bonding or calendering generally used with spunbond webs.

          The term "fiber" is used herein to mean a monocomponent fiber; a bicomponent or conjugate fiber (for convenience, the term "bicomponent" will often be used to mean fibers that consist of two components as well as fibers that consist of more than two components); and a fiber section of a bicomponent fiber, i.e., a section occupying part of  
20           the cross-section of and extending over the length of the bicomponent fiber. Monocomponent fibrous webs are often preferred, and the combination of orientation and bondability offered by the invention makes possible high-strength bondable webs using monocomponent fibers. Other webs of the invention comprise bicomponent fibers in which the described fiber of varying morphology is one component (or fiber section) of a  
25           multicomponent fiber, i.e., occupies only part of the cross-section of the fiber and is continuous along the length of the fiber. A fiber (i.e., fiber section) as described can perform bonding functions as part of a multicomponent fiber as well as providing high strength properties.

          Nonwoven fibrous webs of the invention can be prepared by fiber-forming  
30           processes in which filaments of fiber-forming material are extruded, subjected to orienting forces, and passed through a turbulent field of gaseous currents while at least some of the extruded filaments are in a softened condition and reach their freezing temperature (e.g.,

the temperature at which the fiber-forming material of the filaments solidifies) while in the turbulent field. A preferred method for making fibrous webs of the invention comprises a) extruding filaments of fiber-forming material; b) directing the filaments through a processing chamber in which gaseous currents apply a longitudinal, or orienting stress, to the filaments; c) passing the filaments through a turbulent field after they exit the processing chamber; and d) collecting the processed filaments; the temperature of the filaments being controlled so that at least some of the filaments solidify after they exit the processing chamber but before they are collected. Preferably, the processing chamber is defined by two parallel walls, at least one of the walls being instantaneously movable toward and away from the other wall and being subject to movement means for providing instantaneous movement during passage of the filaments.

In addition to variation in morphology along the length of a fiber, there can be variation in morphology between fibers of a fibrous web of the invention. For example, some fibers can be of larger diameter than others as a result of experiencing less orientation in the turbulent field. Larger-diameter fibers often have a less-ordered morphology, and may participate (i.e., be active) in bonding operations to a different extent than smaller-diameter fibers, which often have a more highly developed morphology. The majority of bonds in a fibrous web of the invention may involve such larger-diameter fibers, which often, though not necessarily, themselves vary in morphology. But longitudinal segments of less-ordered morphology (and therefore lower softening temperature) occurring within a smaller-diameter varied-morphology fiber preferably also participate in bonding of the web.

In the drawings:

Figure 1 is a schematic overall diagram of apparatus useful for forming a nonwoven fibrous web of the invention.

Figure 2 is an enlarged side view of a processing chamber useful for forming a nonwoven fibrous web of the invention, with mounting means for the chamber not shown.

Figure 3 is a top view, partially schematic, of the processing chamber shown in Figure 2 together with mounting and other associated apparatus.

Figures 4a, 4b, and 4c are schematic diagrams through illustrative fiber bonds in webs of the invention.

Figure 5 is a schematic diagram of a portion of a web of the invention, showing fibers crossing over and bonded to one another.

Figures 6, 8 and 11 are scanning electron micrographs of illustrative webs from two working examples of the invention described below.

5            Figures 8, 9, and 10 are graphs of birefringence values measured on illustrative webs from working examples of the invention described below.

Figure 12 is a graph of differential scanning calorimetry plots for webs of a working example described below.

10            Figure 1 shows an illustrative apparatus that can be used to prepare nonwoven fibrous webs of the invention. Fiber-forming material is brought to an extrusion head 10 -  
- in this particular illustrative apparatus, by introducing a fiber-forming material into  
hoppers 11, melting the material in an extruder 12, and pumping the molten material into  
the extrusion head 10 through a pump 13. Although solid polymeric material in pellet or  
other particulate form is most commonly used and melted to a liquid, pumpable state,  
15            other fiber-forming liquids such as polymer solutions could also be used.

The extrusion head 10 may be a conventional spinnerette or spin pack, generally including multiple orifices arranged in a regular pattern, e.g., straightline rows. Filaments  
15 of fiber-forming liquid are extruded from the extrusion head and conveyed to a processing chamber or attenuator 16. As part of a desired control of the process, the  
20            distance 17 the extruded filaments 15 travel before reaching the attenuator 16 can be adjusted, as can the conditions to which they are exposed. Typically, some quenching streams of air or other gas 18 are presented to the extruded filaments by conventional methods and apparatus to reduce the temperature of the extruded filaments 15. Sometimes the quenching streams may be heated to obtain a desired temperature of the extruded  
25            filaments and/or to facilitate drawing of the filaments. There may be one or more streams of air (or other fluid) -- e.g., a first stream 18a blown transversely to the filament stream, which may remove undesired gaseous materials or fumes released during extrusion; and a second quenching stream 18b that achieves a major desired temperature reduction. Depending on the process being used or the form of finished product desired, the  
30            quenching stream may be sufficient to solidify some of the extruded filaments 15 before they reach the attenuator 16. But in general, in a method of the invention extruded filamentary components are still in a softened or molten condition when they enter the

attenuator. Alternatively, no quenching streams are used; in such a case ambient air or other fluid between the extrusion head 10 and the attenuator 16 may be a medium for any temperature change in the extruded filamentary components before they enter the attenuator.

5           The filaments 15 pass through the attenuator 16, as discussed in more detail below, and then exit. Most often, as pictured in Figure 1, they exit onto a collector 19 where they are collected as a mass of fibers 20 that may or may not be coherent and take the form of a handleable web. The collector 19 is generally porous and a gas-withdrawal device 14 can be positioned below the collector to assist deposition of fibers onto the collector.

10           Between the attenuator 16 and collector 19 lies a field 21 of turbulent currents of air or other fluid. Turbulence occurs as the currents passing through the attenuator reach the unconfined space at the end of the attenuator, where the pressure that existed within the attenuator is released. The current stream widens as it exits the attenuator, and eddies develop within the widened stream. These eddies – whirlpools of currents running in  
15 different directions from the main stream – subject filaments within them to forces different from the straight-line forces the filaments are generally subjected to within and above the attenuator. For example, filaments can undergo a to-and-fro flapping within the eddies and be subjected to forces that have a vector component transverse to the length of the fiber.

20           The processed filaments are long and travel a tortuous and random path through the turbulent field. Different portions of the filaments experience different forces within the turbulent field. To some extent the lengthwise stresses on portions of at least some filaments are relaxed, and those portions consequently become less oriented than those portions that experience a longer application of the lengthwise stress.

25           At the same time, the filaments are cooling. The temperature of the filaments within the turbulent field can be controlled, for example, by controlling the temperature of the filaments as they enter the attenuator (e.g., by controlling the temperature of the extruded fiber-forming material, the distance between the extrusion head and the attenuator, and the amount and nature of the quenching streams), the length of the  
30 attenuator, the velocity and temperature of the filaments as they move through the attenuator, and the distance of the attenuator from the collector 19. By causing some or all of the filaments and segments thereof to cool within the turbulent field to the temperature



at which the filaments or segments solidify, the differences in orientation experienced by different portions of the filaments, and the consequent morphology of the fibers, become frozen in; i.e., the molecules are thermally trapped in their aligned position. The different orientations that different fibers and different segments experienced as they passed  
5 through the turbulent field are retained to at least some extent in the fibers as collected on the collector 19.

Depending on the chemical composition of the filaments, different kinds of morphology can be obtained in a fiber. As discussed below, the possible morphological forms within a fiber include amorphous, ordered or rigid amorphous, oriented amorphous,  
10 crystalline, oriented or shaped crystalline, and extended-chain crystallization (sometimes called strain-induced crystallization). Different ones of these different kinds of morphology can exist along the length of a single fiber, or can exist in different amounts or at different degrees of order or orientation. And these differences can exist to the extent that longitudinal segments along the length of the fiber differ in softening characteristics  
15 during a bonding operation.

After passing through a processing chamber and turbulent field as described, but prior to collection, extruded filaments or fibers may be subjected to a number of additional processing steps not illustrated in Figure 1, e.g., further drawing, spraying, etc. Upon  
20 collection, the whole mass 20 of collected fibers may be conveyed to other apparatus such as a bonding oven, through-air bonder, calenders, embossing stations, laminators, cutters and the like; or it may be passed through drive rolls 22 and wound into a storage roll 23. Quite often, the mass is conveyed to an oven or through-air bonder, where the mass is heated to develop autogenous bonds that stabilize or further stabilize the mass as a handleable web. The invention is particularly useful as a direct-web-formation process in  
25 which a fiber-forming polymeric material is converted into a web in one essentially direct operation (including extrusion of filaments, processing of the filaments, solidifying of the filaments in a turbulent field, collection of the processed filaments, and, if needed, further processing to transform the collected mass into a web). Nonwoven fibrous webs of the invention preferably comprise directly collected fibers or directly collected masses of  
30 fibers, meaning that the fibers are collected as a web-like mass as they leave the fiber-forming apparatus (other components such as staple fibers or particles can be collected together with the mass of directly formed fibers as described later herein).

Alternatively, fibers exiting the attenuator may take the form of filaments, tow or yarn, which may be wound onto a storage spool or further processed. Fibers of uniform diameter that vary in morphology along their length as described herein are understood to be novel and useful. That is, fibers having portions at least five centimeters long that have a 10-percent-or-less change in diameter but vary in morphology along that length, as indicated for example, by the presence of active and passive segments during a selected bonding operation, or by different degrees of order or orientation along the length, or by tests described later herein measuring gradations of density or of birefringence along the length of the fiber or fiber portion, are understood to be novel and useful. Such fibers or collections of fibers can be formed into webs, often after being chopped to carding lengths and optionally blended with other fibers, and combined into a nonwoven web form.

The apparatus pictured in Figure 1 is of advantage in practicing the invention because it allows control over the temperature of filaments passing through the attenuator, allows filaments to pass through the chamber at fast rates, and can apply high stresses on the filaments that introduce desired high degrees of orientation on the filaments.

(Apparatus as shown in the drawings has also been described in U.S. patent application, Serial No. 09/835,904, filed April 16, 2001, and the corresponding PCT Application No. PCT/US01/46545, filed November 8, 2001 and published as WO 02/055782 on July 18, 2002, both of which are incorporated by reference in the present application.) Some advantageous features of the apparatus are further shown in Figure 2, which is an enlarged side view of a representative processing device or attenuator, and Figure 3, which is a top view, partially schematic, of the processing apparatus shown in Figure 2 together with mounting and other associated apparatus. The illustrative attenuator 16 comprises two movable halves or sides 16a and 16b separated so as to define between them the processing chamber 24: the facing surfaces of the sides 16a and 16b form the walls of the chamber. As seen from the top view in Figure 3, the processing or attenuation chamber 24 is generally an elongated slot, having a transverse length 25 (transverse to the path of travel of filaments through the attenuator), which can vary depending on the number of filaments being processed.

Although existing as two halves or sides, the attenuator functions as one unitary device and will be first discussed in its combined form. (The structure shown in Figures 2 and 3 is representative only, and a variety of different constructions may be used.) The

representative attenuator 16 includes slanted entry walls 27, which define an entrance space or throat 24a of the attenuation chamber 24. The entry walls 27 preferably are curved at the entry edge or surface 27a to smooth the entry of air streams carrying the extruded filaments 15. The walls 27 are attached to a main body portion 28, and may be provided with a recessed area 29 to establish a gap 30 between the body portion 28 and wall 27. Air may be introduced into the gaps 30 through conduits 31, creating air knives (represented by the arrows 32) that increase the velocity of the filaments traveling through the attenuator, and that also have a further quenching affect on the filaments. The attenuator body 28 is preferably curved at 28a to smooth the passage of air from the air knife 32 into the passage 24. The angle ( $\alpha$ ) of the surface 28b of the attenuator body can be selected to determine the desired angle at which the air knife impacts a stream of filaments passing through the attenuator. Instead of being near the entry to the chamber, the air knives may be disposed further within the chamber.

The attenuation chamber 24 may have a uniform gap width (the horizontal distance 33 on the page of Figure 2 between the two attenuator sides is herein called the gap width) over its longitudinal length through the attenuator (the dimension along a longitudinal axis 26 through the attenuation chamber is called the axial length). Alternatively, as illustrated in Figure 2, the gap width may vary along the length of the attenuator chamber. Preferably, the attenuation chamber is narrower internally within the attenuator; e.g., as shown in Figure 2, the gap width 33 at the location of the air knives is the narrowest width, and the attenuation chamber expands in width along its length toward the exit opening 34, e.g., at an angle  $\beta$ . Such a narrowing internally within the attenuation chamber 24, followed by a broadening, creates a venturi effect that increases the mass of air inducted into the chamber and adds to the velocity of filaments traveling through the chamber. In a different embodiment, the attenuation chamber is defined by straight or flat walls; in such embodiments the spacing between the walls may be constant over their length, or alternatively the walls may slightly diverge or converge over the axial length of the attenuation chamber. In all these cases, the walls defining the attenuation chamber are regarded as parallel herein, because the deviation from exact parallelism is relatively slight. As illustrated in Figure 2, the walls defining the main portion of the longitudinal length of the passage 24 may take the form of plates 36 that are separate from, and attached to, the main body portion 28.

The length of the attenuation chamber 24 can be varied to achieve different effects; variation is especially useful with the portion between the air knives 32 and the exit opening 34, sometimes called herein the chute length 35. The angle between the chamber walls and the axis 26 may be wider near the exit 34 to change the distribution of fibers onto the collector as well as to change the turbulence and patterns of the current field at the exit of the attenuator. Structure such as deflector surfaces, Coanda curved surfaces, and uneven wall lengths also may be used at the exit to achieve a desired current force-field as well as spreading or other distribution of fibers. In general, the gap width, chute length, attenuation chamber shape, etc. are chosen in conjunction with the material being processed and the mode of treatment desired to achieve desired effects. For example, longer chute lengths may be useful to increase the crystallinity of prepared fibers. Conditions are chosen and can be widely varied to process the extruded filaments into a desired fiber form.

As illustrated in Figure 3, the two sides 16a and 16b of the representative attenuator 16 are each supported through mounting blocks 37 attached to linear bearings 38 that slide on rods 39. The bearing 38 has a low-friction travel on the rod through means such as axially extending rows of ball-bearings disposed radially around the rod, whereby the sides 16a and 16b can readily move toward and away from one another. The mounting blocks 37 are attached to the attenuator body 28 and a housing 40 through which air from a supply pipe 41 is distributed to the conduits 31 and air knives 32.

In this illustrative embodiment, air cylinders 43a and 43b are connected, respectively, to the attenuator sides 16a and 16b through connecting rods 44 and apply a clamping force pressing the attenuator sides 16a and 16b toward one another. The clamping force is chosen in conjunction with the other operating parameters so as to balance the pressure existing within the attenuation chamber 24. In other words, under preferred operating conditions the clamping force is in balance or equilibrium with the force acting internally within the attenuation chamber to press the attenuator sides apart, e.g., the force created by the gaseous pressure within the attenuator. Filamentary material can be extruded, passed through the attenuator and collected as finished fibers while the attenuator parts remain in their established equilibrium or steady-state position and the attenuation chamber or passage 24 remains at its established equilibrium or steady-state gap width.

During operation of the representative apparatus illustrated in Figures 1-3, movement of the attenuator sides or chamber walls generally occurs only when there is a perturbation of the system. Such a perturbation may occur when a filament being processed breaks or tangles with another filament or fiber. Such breaks or tangles are often accompanied by an increase in pressure within the attenuation chamber 24, e.g., because the forward end of the filament coming from the extrusion head or the tangle is enlarged and creates a localized blockage of the chamber 24. The increased pressure can be sufficient to force the attenuator sides or chamber walls 16a and 16b to move away from one another. Upon this movement of the chamber walls the end of the incoming filament or the tangle can pass through the attenuator, whereupon the pressure in the attenuation chamber 24 returns to its steady-state value before the perturbation, and the clamping pressure exerted by the air cylinders 43 returns the attenuator sides to their steady-state position. Other perturbations causing an increase in pressure in the attenuation chamber include "drips," i.e., globular liquid pieces of fiber-forming material falling from the exit of the extrusion head upon interruption of an extruded filament, or accumulations of extruded filamentary material that may engage and stick to the walls of the attenuation chamber or to previously deposited fiber-forming material.

In effect, one or both of the attenuator sides 16a and 16b "float," i.e., are not held in place by any structure but instead are mounted for a free and easy movement laterally in the direction of the arrows 50 in Figure 1. In a preferred arrangement, the only forces acting on the attenuator sides other than friction and gravity are the biasing force applied by the air cylinders and the internal pressure developed within the attenuation chamber 24. Other clamping means than the air cylinder may be used, such as a spring(s), deformation of an elastic material, or cams; but the air cylinder offers a desired control and variability.

Many alternatives are available to cause or allow a desired movement of the processing chamber wall(s). For example, instead of relying on fluid pressure to force the wall(s) of the processing chamber apart, a sensor within the chamber (e.g., a laser or thermal sensor detecting buildup on the walls or plugging of the chamber) may be used to activate a servomechanical mechanism that separates the wall(s) and then returns them to their steady-state position. In another useful apparatus of the invention, one or both of the attenuator sides or chamber walls is driven in an oscillating pattern, e.g., by a servomechanical, vibratory or ultrasonic driving device. The rate of oscillation can vary

within wide ranges, including, for example, at least rates of 5,000 cycles per minute to 60,000 cycles per second.

5 In still another variation, the movement means for both separating the walls and returning them to their steady-state position takes the form simply of a difference between the fluid pressure within the processing chamber and the ambient pressure acting on the exterior of the chamber walls. More specifically, during steady-state operation, the pressure within the processing chamber (a summation of the various forces acting within the processing chamber established, for example, by the internal shape of the processing chamber, the presence, location and design of air knives, the velocity of a fluid stream entering the chamber, etc.) is in balance with the ambient pressure acting on the outside of the chamber walls. If the pressure within the chamber increases because of a perturbation of the fiber-forming process, one or both of the chamber walls moves away from the other wall until the perturbation ends, whereupon pressure within the processing chamber is reduced to a level less than the steady-state pressure (because the gap width between the chamber walls is greater than at the steady-state operation). Thereupon, the ambient pressure acting on the outside of the chamber walls forces the chamber wall(s) back until the pressure within the chamber is in balance with the ambient pressure, and steady-state operation occurs. Lack of control over the apparatus and processing parameters can make sole reliance on pressure differences a less desired option.

20 In sum, besides being instantaneously movable and in some cases “floating,” the wall(s) of the processing chamber are also generally subject to means for causing them to move in a desired way. The walls can be thought of as generally connected, e.g., physically or operationally, to means for causing a desired movement of the walls. The movement means may be any feature of the processing chamber or associated apparatus, or an operating condition, or a combination thereof that causes the intended movement of the movable chamber walls – movement apart, e.g., to prevent or alleviate a perturbation in the fiber-forming process, and movement together, e.g., to establish or return the chamber to steady-state operation.

30 In the embodiment illustrated in Figures 1-3, the gap width 33 of the attenuation chamber 24 is interrelated with the pressure existing within the chamber, or with the fluid flow rate through the chamber and the fluid temperature. The clamping force matches the pressure within the attenuation chamber and varies depending on the gap width of the

attenuation chamber: for a given fluid flow rate, the narrower the gap width, the higher the pressure within the attenuation chamber, and the higher must be the clamping force.

Lower clamping forces allow a wider gap width. Mechanical stops, e.g., abutting structure on one or both of the attenuator sides 16a and 16b may be used to assure that minimum or maximum gap widths are maintained.

In one useful arrangement, the air cylinder 43a applies a larger clamping force than the cylinder 43b, e.g., by use in cylinder 43a of a piston of larger diameter than used in cylinder 43b. This difference in force establishes the attenuator side 16b as the side that tends to move most readily when a perturbation occurs during operation. The difference in force is about equal to and compensates for the frictional forces resisting movement of the bearings 38 on the rods 39. Limiting means can be attached to the larger air cylinder 43a to limit movement of the attenuator side 16a toward the attenuator side 16b. One illustrative limiting means, as shown in Figure 3, uses as the air cylinder 43a a double-rod air cylinder, in which the second rod 46 is threaded, extends through a mounting plate 47, and carries a nut 48 which may be adjusted to adjust the position of the air cylinder. Adjustment of the limiting means, e.g., by turning the nut 48, positions the attenuation chamber 24 into alignment with the extrusion head 10.

Because of the described instantaneous separation and reclosing of the attenuator sides 16a and 16b, the operating parameters for a fiber-forming operation are expanded. Some conditions that would previously make the process inoperable – e.g., because they would lead to filament breakage requiring shutdown for rethreading -- become acceptable; upon filament breakage, rethreading of the incoming filament end generally occurs automatically. For example, higher velocities that lead to frequent filament breakage may be used. Similarly, narrow gap widths, which cause the air knives to be more focused and to impart more force and greater velocity on filaments passing through the attenuator, may be used. Or filaments may be introduced into the attenuation chamber in a more molten condition, thereby allowing greater control over fiber properties, because the danger of plugging the attenuation chamber is reduced. The attenuator may be moved closer to or further from the extrusion head to control among other things the temperature of the filaments when they enter the attenuation chamber.

Although the chamber walls of the attenuator 16 are shown as generally monolithic structures, they can also take the form of an assemblage of individual parts each mounted

for the described instantaneous or floating movement. The individual parts comprising one wall engage one another through sealing means so as to maintain the internal pressure within the processing chamber 24. In a different arrangement, flexible sheets of a material such as rubber or plastic form the walls of the processing chamber 24, whereby the chamber can deform locally upon a localized increase in pressure (e.g., because of a plugging caused by breaking of a single filament or group of filaments). A series or grid of biasing means may engage the segmented or flexible wall; sufficient biasing means are used to respond to localized deformations and to bias a deformed portion of the wall back to its undeformed position. Alternatively, a series or grid of oscillating means may engage the flexible wall and oscillate local areas of the wall. Or, in the manner discussed above, a difference between the fluid pressure within the processing chamber and the ambient pressure acting on the wall or localized portion of the wall may be used to cause opening of a portion of the wall(s), e.g., during a process perturbation, and to return the wall(s) to the undeformed or steady-state position, e.g., when the perturbation ends. Fluid pressure may also be controlled to cause a continuing state of oscillation of a flexible or segmented wall.

As will be seen, in the preferred embodiment of processing chamber illustrated in Figures 2 and 3, there are no sidewalls at the ends of the transverse length of the chamber. The result is that fibers passing through the chamber can spread outwardly outside the chamber as they approach the exit of the chamber. Such a spreading can be desirable to widen the mass of fibers collected on the collector. In other embodiments, the processing chamber does include side walls, though a single side wall at one transverse end of the chamber is not attached to both chamber sides 16a and 16b, because attachment to both chamber sides would prevent separation of the sides as discussed above. Instead, a sidewall(s) may be attached to one chamber side and move with that side when and if it moves in response to changes of pressure within the passage. In other embodiments, the side walls are divided, with one portion attached to one chamber side, and the other portion attached to the other chamber side, with the sidewall portions preferably overlapping if it is desired to confine the stream of processed fibers within the processing chamber.

While apparatus as shown, in which the walls are instantaneously movable, are much preferred, the invention can also be run – generally with less convenience and



efficiency – with apparatus using processing chambers as taught in the prior art in which the walls defining the processing chamber are fixed in position.

A wide variety of fiber-forming materials may be used to make fibrous webs of the invention. Either organic polymeric materials, or inorganic materials, such as glass or ceramic materials, may be used. While the invention is particularly useful with fiber-forming materials in molten form, other fiber-forming liquids such as solutions or suspensions may also be used. Any fiber-forming organic polymeric materials may be used, including the polymers commonly used in fiber formation such as polyethylene, polypropylene, polyethylene terephthalate, nylon, and urethanes. Some polymers or materials that are more difficult to form into fibers by spunbond or meltblown techniques can be used, including amorphous polymers such as cyclic olefins (which have a high melt viscosity that limits their utility in conventional direct-extrusion techniques), block copolymers, styrene-based polymers, polycarbonates, acrylics, polyacrylonitriles, and adhesives (including pressure-sensitive varieties and hot-melt varieties). (With respect to block copolymers, it may be noted that the individual blocks of the copolymers may vary in morphology, as when one block is crystalline or semicrystalline and the other block is amorphous; the variation in morphology exhibited by fibers of the invention is not such a variation, but instead is a more macro property in which several molecules participate in forming a generally physically identifiable portion of a fiber.) The specific polymers listed here are examples only, and a wide variety of other polymeric or fiber-forming materials are useful. Interestingly, fiber-forming processes of the invention using molten polymers can often be performed at lower temperatures than traditional direct extrusion techniques, which offers a number of advantages.

Fibers also may be formed from blends of materials, including materials into which certain additives have been blended, such as pigments or dyes. As noted above, bicomponent fibers, such as core-sheath or side-by-side bicomponent fibers, may be prepared (“bicomponent” herein includes fibers with more than two components). In addition, different fiber-forming materials may be extruded through different orifices of the extrusion head so as to prepare webs that comprise a mixture of fibers. In other embodiments of the invention other materials are introduced into a stream of fibers prepared according to the invention before or as the fibers are collected so as to prepare a blended web. For example, other staple fibers may be blended in the manner taught in

U.S. Patent No. 4,118,531; or particulate material may be introduced and captured within the web in the manner taught in U.S. Patent No. 3,971,373; or microwebs as taught in U.S. Patent No. 4,813,948 may be blended into the webs. Alternatively, fibers prepared according to the present invention may be introduced into a stream of other fibers to  
5 prepare a blend of fibers.

Besides the variation in orientation between fibers and segments discussed above, webs and fibers of the invention can exhibit other unique characteristics. For example, in some collected webs, fibers are found that are interrupted, i.e., are broken, or entangled with themselves or other fibers, or otherwise deformed as by engaging a wall of the  
10 processing chamber. The fiber segments at the location of the interruption – i.e., the fiber segments at the point of a fiber break, and the fiber segments in which an entanglement or deformation occurs -- are all termed an interrupting fiber segment herein, or more commonly for shorthand purposes, are often simply termed “fiber ends”: these interrupting fiber segments form the terminus or end of an unaffected length of fiber, even though in  
15 the case of entanglements or deformations there often is no actual break or severing of the fiber.

The fiber ends have a fiber form (as opposed to a globular shape as sometimes obtained in meltblowing or other previous methods) but are usually enlarged in diameter over the medial or intermediate portions of the fiber; usually they are less than 300  
20 micrometers in diameter. Often, the fiber ends, especially broken ends, have a curly or spiral shape, which causes the ends to entangle with themselves or other fibers. And the fiber ends may be bonded side-by-side with other fibers, e.g., by autogenous coalescing of material of the fiber end with material of an adjacent fiber.

Fiber ends as described arise because of the unique character of the fiber-forming  
25 process illustrated in Figs. 1 -3, which (as will be discussed in further detail below) can continue in spite of breaks and interruptions in individual fiber formation. Such fiber ends may not occur in all collected webs of the invention, but can occur at least at some useful operating process parameters. Individual fibers may be subject to an interruption, e.g., may break while being drawn in the processing chamber, or may entangle with themselves  
30 or another fiber as a result of being deflected from the wall of the processing chamber or as a result of turbulence within the processing chamber; but notwithstanding such interruption, the fiber-forming process of the invention continues. The result is that the

collected web can include a significant and detectable number of the fiber ends, or interrupting fiber segments where there is a discontinuity in the fiber. Since the interruption typically occurs in or after the processing chamber, where the fibers are typically subjected to drawing forces, the fibers are under tension when they break, entangle or deform. The break, or entanglement generally results in an interruption or release of tension allowing the fiber ends to retract and gain in diameter. Also, broken ends are free to move within the fluid currents in the processing chamber, which at least in some cases leads to winding of the ends into a spiral shape and entangling with other fibers. Webs including fibers with enlarged fibrous ends can have the advantage that the fiber ends may comprise a more easily softened material adapted to increase bonding of a web; and the spiral shape can increase coherency of the web. Though in fibrous form, the fiber ends have a larger diameter than intermediate or middle portions. The interrupting fiber segments, or fiber ends, generally occur in a minor amount. The intermediate main portion of the fibers (“middles” comprising “medial segments”) have the characteristics noted above. The interruptions are isolated and random, i.e., they do not occur in a regular repetitive or predetermined manner.

The medially located longitudinal segments discussed above (often referred to herein simply as longitudinal segments or medial segments) differ from the just-discussed fiber ends, among other ways, in that the longitudinal segments generally have the same or similar diameter as adjacent longitudinal segments. Although the forces acting on adjacent longitudinal segments can be sufficiently different from one another to cause the noted differences in morphology between the segments, the forces are not so different as to substantially change the diameter or draw ratio of the adjacent longitudinal segments within the fibers. Preferably, adjacent longitudinal segments differ in diameter by no more than about 10 percent. More generally, significant lengths -- such as five centimeters or more -- of fibers in webs of the invention do not vary in diameter by more than about 10 percent. Such a uniformity in diameter is advantageous, for example, because it contributes to a uniformity of properties within the web, and allows for a lofty and low-density web. Such uniformity of properties and loftiness are further enhanced when webs of the invention are bonded without substantial deformation of fibers as can occur in point-bonding or calendering of a web. Over the full length of the fiber, the diameter may (but preferably does not) vary substantially more than 10 percent; but the change is

gradual so that adjacent longitudinal segments are of the same or similar diameter. The longitudinal segments may vary widely in length, from very short lengths as long as a fiber diameter (e.g., about 10 micrometers) to longer lengths such as 30 centimeters or more. Often the longitudinal segments are less than about two millimeters in length.

5           While adjacent longitudinal segments may not differ greatly in diameter in webs of the invention, there may be significant variation in diameter from fiber to fiber. As a whole, a particular fiber may experience significant differences from another fiber in the aggregate of forces acting on the fiber, and those differences can cause the diameter and draw ratio of the particular fiber to be different from those of other fibers. Larger-  
10 diameter fibers tend to have a lesser draw ratio and a less-developed morphology than smaller-diameter fibers. Larger-diameter fibers can be more active in bonding operations than smaller-diameter fibers, especially in autogenous bonding operations. Within a web, the predominant bonding may be obtained from larger-diameter fibers. However, we have also observed webs in which bonding seems more likely to occur between small-diameter  
15 fibers. The range of fiber diameters within a web usually can be controlled by controlling the various parameters of the fiber-forming operation. Narrow ranges of diameters are often preferred, for example, to make properties of the web more uniform and to minimize the heat that is applied to the web to achieve bonding.

          Although differences in morphology exist within a web sufficiently for improved  
20 bonding, the fibers also can be sufficiently developed in morphology to provide desired strength properties, durability, and dimensional stability. The fibers themselves can be strong, and the improved bonds achieved because of the more active bonding segments and fibers further improves web strength. The combination of good web strength with increased convenience and performance of bonds achieves good utility for webs of the  
25 invention. In the case of crystalline and semicrystalline polymeric materials, preferred embodiments of the invention provide nonwoven fibrous webs comprising chain-extended crystalline structure (also called strain-induced crystallization) in the fibers, thereby increasing strength and stability of the web (chain-extended crystallization, as well as other kinds of crystallization, can be detected by X-ray analysis). Combination of that  
30 structure with autogenous bonds, sometimes circumference-penetrating bonds, is a further advantage. The fibers of the web can be rather uniform in diameter over most of their length and independent from other fibers to obtain webs having desired loft properties.

Lofts of 90 percent (the inverse of solidity and comprising the ratio of the volume of the air in a web to the total volume of the web multiplied by 100) or more can be obtained and are useful for many purposes such as filtration or insulation. Even the less-oriented fiber segments preferably have undergone some orientation that enhances fiber strength along the full length of the fiber.

In sum, fibrous webs of the invention generally include fibers that have longitudinal segments differing from one another in morphology and consequent bonding characteristics, and that also can include fiber ends that exhibit morphologies and bonding characteristics differing from those of at least some other segments in the fibers; and the fibrous webs can also include fibers that differ from one another in diameter and have differences in morphology and bonding characteristics from other fibers within the web.

Other fiber-forming materials that are not crystalline can still benefit from high degrees of orientation. For example, noncrystalline forms of polycarbonate, polymethylmethacrylate, and polystyrene, when highly oriented, offer improved mechanical properties. The morphology of fibers of such polymers can vary along the length of the fiber, for example, from amorphous to ordered amorphous to oriented amorphous and to different degrees of order or orientation. (Application Serial No.10/151,780, filed May 20, 2002 (Attorney's Docket No. 57738US002), is particularly directed to nonwoven amorphous fibrous webs and methods for making them, and is incorporated herein by reference.)

The final morphology of the polymer chains in the filaments can be influenced both by the turbulent field and by selection of other operating parameters, such as degree of solidification of filament entering the attenuator, velocity and temperature of air stream introduced into the attenuator by the air knives, and axial length, gap width and shape (because, for example, shape influences the venturi effect) of the attenuator passage.

The best bonds are obtained when the bonding segment flows sufficiently to form a circumference-penetrating type of bond as illustrated in the schematic diagrams Figs. 4a and 4b. Such bonds develop more extensive contact between bonded fibers, and the increased area of contact increases the strength of the bond. Fig. 4a illustrates a bond in which one fiber or segment 52 deforms while another fiber or segment 53 essentially retains its cross-sectional shape. Fig. 4b illustrates a bond in which two fibers 55 and 56 are bonded and each deforms in cross-sectional shape. In both Figs. 4a and 4b,

circumference-penetrating bonds are shown: the dotted line 54 in Fig. 4a shows the shape the fiber 52 would have except for the deformation caused by penetration of the fiber 53; and the dotted lines 57 and 58 in Fig. 4b show the shapes the fibers 56 and 55, respectively, would have except for the bond. Fig. 4c schematically illustrates two fibers bonded together in a bond that may be different from a circumference-penetrating bond, in which material from exterior portions (e.g., a concentric portion or portions) of one or more of the fibers has coalesced to join the two fibers together without actually penetrating the circumference of either of the fibers.

The bonds pictured in Figs. 4a-4c can be autogenous bonds, e.g., obtained by heating a web of the invention without application of calendering pressure. Such bonds allow softer hand to the web and greater retention of loft under pressure. However, pressure bonds as in point-bonding or area-wide calendering are also useful. Bonds can also be formed by application of infrared, laser, ultrasonic or other energy forms that thermally or otherwise activate bonding between fibers. Solvent application may also be used. Webs can exhibit both autogenous bonds and pressure-formed bonds, as when the web is subjected only to limited pressure that is instrumental in only some of the bonds. Webs having autogenous bonds are regarded as autogenously bonded herein, even if other kinds of pressure-formed bonds are also present in limited amounts. In general, in practicing the invention a bonding operation is desirably selected that allows some longitudinal segments to soften and be active in bonding to an adjacent fiber or portion of a fiber, while other longitudinal segments remain passive or inactive in achieving bonds.

Figure 5 illustrates the active/passive segment feature of the fibers used in nonwoven fibrous webs of the present invention. The collection of fibers illustrated in Figure 5 include longitudinal segments that, within the boundaries of Figure 5, are active along their entire length, longitudinal segments that are passive along their entire length, and fibers that include both active and passive longitudinal segments. The portions of the fibers depicted with cross-hatching are active and the portions without cross-hatching are passive. Although the boundaries between active and passive longitudinal segments are depicted as sharp for illustrative purposes, it should be understood that the boundaries may be more gradual in actual fibers.

More specifically, fiber 62 is depicted as being completely passive within the boundaries of Figure 5. Fibers 63 and 64 are depicted with both active and passive

segments within the boundaries of Figure 5. Fiber 65 is depicted as being completely active within the boundaries of Figure 5. Fiber 66 is depicted with both active and passive segments within the boundaries of Figure 5. Fiber 67 is depicted as being active along its entire length as seen within Figure 5.

5           The intersection 70 between fibers 63, 64 and 65 will typically result in a bond because all of the fiber segments at that intersection are active (“intersection” herein means a place where fibers contact one another; three-dimensional viewing of a sample web will typically be needed to examine whether there is contacting and/or bonding). The intersection 71 between fibers 63, 64 and 66 will also typically result in a bond because  
10 fibers 63 and 64 are active at that intersection (even though fiber 66 is passive at the intersection). Intersection 71 illustrates the principle that, where an active segment and a passive segment contact each other, a bond will typically be formed at that intersection. That principle is also seen at intersection 72 where fibers 62 and 67 cross, with a bond being formed between the active segment of fiber 67 and the passive segment of fiber 62.  
15 Intersections 73 and 74 illustrate bonds between the active segments of fibers 65 and 67 (intersection 73) and the active segments of fibers 66 and 67 (intersection 74). At intersection 75, a bond will typically be formed between the passive segment of fiber 62 and the active segment of fiber 65. A bond will not, however, typically be formed  
20 between the passive segment of fiber 62 and the passive segment of fiber 66 that also cross at intersection 75. As a result, intersection 75 illustrates the principle that two passive segments in contact with each other will not typically result in a bond. Intersection 76 will typically include bonds between the passive segment of fiber 62 and the active segments of fibers 63 and 64 that meet at that intersection.

25           Fibers 63 and 64 illustrate that where two fibers 63 and 64 lie next to each other along portions of their lengths, the fibers 63 and 64 will typically bond provided that one or both of the fibers are active (such bonding may occur during preparation of the fibers, which is regarded as autogenous bonding herein). As a result, fibers 63 and 64 are depicted as bonded to each other between intersections 71 and 76 because both fibers are active over that distance. In addition, at the upper end of Figure 5, fibers 63 and 64 are  
30 also bonded where only fiber 64 is active. In contrast, at the lower end of Figure 5, fibers 63 and 64 diverge where both fibers transition to passive segments.

Analytical comparisons may be performed on different segments (internal segments as well as fiber ends) of fibers of the invention to show the different characteristics and properties. A variation in density often accompanies the variation in morphology of fibers of the invention, and the variation in density can typically be detected by a Test for Density Gradation Along Fiber Length (sometimes referred to more shortly as the Graded Density test), defined herein. This test is based on a density-gradient technique described in ASTM D1505-85. The technique uses a density-gradient tube, i.e., a graduated cylinder or tube filled with a solution of at least two different-density liquids that mix to provide a gradation of densities over the height of the tube. In a standard test, the liquid mixture fills the tube to at least a 60-centimeter height so as to provide a desired gradual change in the density of the liquid mixture. The density of the liquid should change over the height of the column at a rate between about 0.0030 and 0.0015 gram/cubic centimeter/centimeter of column height. Pieces of fiber from the sample of fibers or web being tested are cut in lengths of 1.0 millimeter and dropped into the tube. Webs are sampled in at least three places at least three inches (7.62 centimeters) apart. The fibers are extended without tension on a glass plate and cut with a razor knife. A glass plate 40 mm long, 22 mm wide, and 0.15 mm thick is used to scrape the cut fiber pieces from the glass plate on which they were cut. The fibers are deionized with a beta radiation source for 30 seconds before they are placed in the column. The fibers are allowed to settle in place for 48 hours before measurements of density and fiber position are made. The pieces settle in the column to their density level, and they assume a position varying from horizontal to vertical depending on whether they vary in density over their length: constant-density pieces assume a horizontal position, while pieces that vary in density deviate from horizontal and assume a more vertical position. In a standard test, twenty pieces of fiber from a sample being tested are introduced into the density-gradient tube. Some fiber pieces may become engaged against the tube wall, and other fiber pieces may become bunched with other fiber pieces. Such engaged or bunched fibers are disregarded, and only the free pieces – not engaged and not bunched – are considered. The test must be re-run if less than half the twenty pieces introduced into the column remain as free pieces.

Angular measurements are obtained visually to the nearest 5-degree increment. The angular disposition of curved fibers is based on the tangent at the midpoint of the



curved fiber. In the standard test of fibers or webs of the invention, at least five of the free pieces generally will assume a position at least thirty degrees from horizontal in the test. More preferably, at least half of the free pieces assume such a position. Also, more preferably the pieces (at least five and preferably at least half the free pieces) assume a position 45 degrees or more from horizontal, or even 60 or 85 degrees or more from horizontal. The greater the angle from horizontal, the greater the differences in density, which tends to correlate with greater differences in morphology, thereby making a bonding operation that distinguishes active from passive segments more likely and more convenient to perform. Also, the higher the number of fiber pieces that are disposed at an angle from horizontal, the more prevalent the variation in morphology tends to be, which further assists in obtaining desired bonding.

Fibers of the invention prepared from crystalline polymers frequently show a difference in birefringence from segment to segment. By viewing a single fiber through a polarized microscope and estimating retardation number using the Michel-Levy chart (see *On-Line Determination of Density and Crystallinity During Melt Spinning*, Vishal Bansal et al, Polymer Engineering and Science, November 1996, Vol. 36, No. 2, pp. 2785-2798), birefringence is obtained with the following formula: birefringence = retardation (nm)/1000D, where D is the fiber diameter in micrometers. We have found that fibers of the invention susceptible to birefringence measurements generally include segments that differ in birefringence number by at least 5%, and preferably at least 10%. Greater differences often occur as shown by the working examples below, some fibers of the invention include segments that differ in birefringence number by 20 or even 50 percent.

Different fibers or portions of a fiber also may exhibit differences in properties as measured by differential scanning calorimetry (DSC). For example, DSC tests on webs of the invention that comprise crystalline or semicrystalline fibers can reveal the presence of chain-extended crystallization by the presence of a dual melting peak. A higher-temperature peak may be obtained for the melting point for a chain-extended, or strain-induced, crystalline portion; and another, generally lower-temperature peak may occur at the melting point for a non-chain-extended, or less-ordered, crystalline portion. (The term "peak" herein means that portion of a heating curve that is attributable to a single process, e.g., melting of a specific molecular portion of a fiber such as a chain-extended portion; sometimes peaks are sufficiently close to one another that one peak has the appearance of

a shoulder of the curve defining the other peak, but they are still regarded as separate peaks, because they represent melting points of distinct molecular fractions.)

In another example, data was obtained using unprocessed amorphous polymers (i.e., pellets of the polymers used to form the fibers of the present invention), amorphous polymeric fibers manufactured according to the present invention, and the amorphous polymeric fibers of the invention after simulated bonding (heating to simulate, e.g., an autogeneous bonding operation).

A difference in the thermal properties between the amorphous polymeric fibers as formed and the amorphous polymeric fibers after simulated bonding can suggest that processing to form the fibers significantly affects the amorphous polymeric material in a manner that improves its bonding performance. All MDSC (modulated differential scanning calorimetry) scans of the fibers as formed and the fibers after simulated bonding presented significant thermal stress release which may be proof of significant levels of orientation in both the fibers as formed and the fibers after simulated bonding. That stress release may, for example, be evidenced by broadening of the glass transition range when comparing the amorphous polymeric fibers as formed with the amorphous polymeric fibers after simulated bonding. Although not wishing to be bound by theory, it may be described that portions of the amorphous polymeric fibers of the present invention exhibit ordered local packing of the molecular structures, sometimes referred to as a rigid or ordered amorphous fraction as a result of the combination thermal treatment and orientation of the filaments during fiber formation (*see, e.g., P.P. Chiu et al., Macromolecules, 33, 9360-9366*).

The thermal behavior of the amorphous polymer used to manufacture the fibers was significantly different than the thermal behavior of the amorphous polymeric fibers before or after simulated bonding. That thermal behavior may preferably include, e.g., changes in the glass transition range. As such, it may be advantageous to characterize the polymeric fibers of the present invention as having a broadened glass transition range in which, as compared to the polymer before processing, both the onset temperature (i.e., the temperature at which the onset of softening occurs) and the end temperature (i.e., the temperature at which substantially all of the polymer reaches the rubbery phase), of the glass transition range for the polymeric fibers move in a manner that increases the overall glass transition range. In other words, the onset temperature decreases and the end

temperature increases. In some instances, it may be sufficient that only the end temperature of the glass transition range increases.

The broadened glass transition range may provide a wider process window in which autogeneous bonding may be performed while the polymeric fibers retain their fibrous shape (because all of the polymer in the fibers does not soften within the narrower glass transition range of known fibers). It should be noted that the broadened glass transition range is preferably measured against the glass transition range of the starting polymer after it has been heated and cooled to remove residual stresses that may be present as a result of, e.g., processing of the polymer into pellets for distribution.

Again, not wishing to be bound by theory, it may be considered that orientation of the amorphous polymer in the fibers may result in a lowering of the onset temperature of the glass transition range. At the other end of the glass transition range, those portions of the amorphous polymeric fibers that reach the rigid or ordered amorphous phase as a result of processing as described above may provide the raised end temperature of the glass transition range. As a result, changes in drawing or orientation of the fibers during manufacturing may be useful to modify the broadening of the glass transition range, e.g., improve the broadening or reduce the broadening.

Upon bonding of a web of the invention by heating it in an oven, the morphology of the fiber segments may be modified. The heating of the oven has an annealing effect. Thus, while oriented fibers may have a tendency to shrink upon heating (which can be minimized by the presence of chain-extended or other types of crystallization), the annealing effect of the bonding operation, together with the stabilizing effect of the bonds themselves, can reduce shrinkage.

The average diameter of fibers prepared according to the invention may range widely. Microfiber sizes (about 10 micrometers or less in diameter) may be obtained and offer several benefits; but fibers of larger diameter can also be prepared and are useful for certain applications; often the fibers are 20 micrometers or less in diameter. Fibers of circular cross-section are most often prepared, but other cross-sectional shapes may also be used. Depending on the operating parameters chosen, e.g., degree of solidification from the molten state before entering the attenuator, the collected fibers may be rather continuous or essentially discontinuous.

Fiber-forming using apparatus as illustrated in Figs. 1 -3 has the advantage that filaments may be processed at very fast velocities not known to be previously available in direct-web-formation processes that use a processing chamber to provide primary attenuation of extruded filamentary material. For example, polypropylene is not known to have been processed at apparent filament speeds of 8000 meters per minute in processes that use such a processing chamber, but such apparent filament speeds are possible with such apparatus (the term apparent filament speed is used, because the speeds are calculated, e.g., from polymer flow rate, polymer density, and average fiber diameter). Even faster apparent filament speeds have been achieved, e.g., 10,000 meters per minute, or even 14,000 or 18,000 meters per minute, and these speeds can be obtained with a wide range of polymers. In addition, large volumes of polymer can be processed per orifice in the extrusion head, and these large volumes can be processed while at the same time moving extruded filaments at high velocity. This combination gives rise to a high productivity index -- the rate of polymer throughput (e.g., in grams per orifice per minute) multiplied by the apparent velocity of extruded filaments (e.g., in meters per minute). The process of the invention can be readily practiced with a productivity index of 9000 or higher, even while producing filaments that average 20 micrometers or less in diameter.

Various processes conventionally used as adjuncts to fiber-forming processes may be used in connection with filaments as they enter or exit from the attenuator, such as spraying of finishes or other materials onto the filaments, application of an electrostatic charge to the filaments, application of water mists, etc. In addition, various materials may be added to a collected web, including bonding agents, adhesives, finishes, and other webs or films.

Although there typically is no reason to do so, filaments may be blown from the extrusion head by a primary gaseous stream in the manner of that used in conventional meltblowing operations. Such primary gaseous streams cause an initial attenuation and drawing of the filaments.

#### Examples 1-4

Apparatus as shown in Figures 1-3 was used to prepare four different fibrous webs from polyethylene terephthalate having an intrinsic viscosity of 0.60 (3M PET resin 651000). In each of the four examples PET was heated to 270 ° C in the

extruder (temperature measured in the extruder 12 near the exit to the pump 13), and the die was heated to a temperature as listed in Table 1 below. The extrusion head or die had four rows of orifices, and each row had 21 orifices, making a total of 84 orifices. The die had a transverse length of 4 inches (101.6 millimeters). The hole diameter was 0.035inch  
 5 (0.889mm) and the L/D ratio was 6.25. The polymer flow rate was 1.6 g/hole/minute.

The distance between the die and attenuator (dimension 17 in Figure 1) was 15 inches (about 38 centimeters), and the distance from the attenuator to the collector (dimension 21 in Figure 1) was 25 inches (slightly less than 64 centimeters). The air knife gap (the dimension 30 in Figure 2) was 0.030 inch  
 10 (0.762 millimeter); the attenuator body angle ( $\alpha$  in Figure 2) was 30 °; room temperature air was passed through the attenuator; and the length of the attenuator chute (dimension 35 in Figure 2) was 6.6 inches (167.64 millimeters). The air knife had a transverse length (the direction of the length 25 of the slot in Figure 3) of about 120 millimeters; and the attenuator body 28 in which the recess for the air knife was formed had a transverse length of about 152 millimeters.  
 15 The transverse length of the wall 36 attached to the attenuator body was 5 inches (127 millimeters).

Other attenuator parameters were also varied as described in Table 1 below, including the gaps at the top and bottom of the attenuator (the dimensions 33 and 34,  
 20 respectively, in Figure 2); and the total volume of air passed through the attenuator (given in actual cubic meters per minute, or ACMM; about half of the listed volume was passed through each air knife 32).

Table 1

| Example No. | Die Temperature (°C) | Attenuator Gap Top (mm) | Attenuator Gap Bottom (mm) | Attenuator Air Flow (ACMM) |
|-------------|----------------------|-------------------------|----------------------------|----------------------------|
| 1           | 270                  | 5.74                    | 4.52                       | 2.35                       |
| 2           | 270                  | 6.15                    | 4.44                       | 3.31                       |
| 3           | 270                  | 4.62                    | 3.68                       | 3.93                       |
| 4           | 290                  | 4.52                    | 3.68                       | 4.81                       |

25

Fibrous webs were collected on a conventional porous web-forming collector in an unbonded condition on a nylon spunbond scrim. The webs were then passed through an oven at 120 ° C for 10 minutes while held on a pin plate that prevented the web from shrinking. The latter step caused autogenous bonding within the webs as illustrated in  
 30 Figure 6, which is a scanning electron micrograph (150X) of a portion of the web of Example 1.

Birefringence studies using a polarized microscope were performed on the prepared webs to examine the degree of orientation within the web and within fibers. Different colors were routinely seen on different longitudinal segments of the fibers. Retardation was estimated using the Michel-Levy chart, and birefringence number  
 5 determined. The range and average birefringence in studies of webs of each example are graphically represented in Figure 7. The ordinate is plotted in units of birefringence, and the abscissa is plotted in the different proportions in which fiber segments exhibiting a particular birefringence number occur for each of the four examples.

Each example was also analyzed to identify variation in birefringence in  
 10 fibers at constant diameter. Fibers of constant diameter were studied, although the fiber sections studied were not necessarily from the same fiber. The results found for Example 4 are presented in the following Table 2. As seen, different colors were also detected. Similar variation in birefringence at constant diameter  
 15 was found for the other examples.

Table 2

| Fiber Diameter ( $\mu\text{m}$ ) | Retardation (nm) | Birefringence | Fiber's Color seen Through Polarized Microscope |
|----------------------------------|------------------|---------------|---|
| 13.0                             | 400              | 0.0307        | Yellow  |
| 13.0                             | 580              | 0.0445        | Purple  |
| 13.0                             | 710              | 0.0544        | Blue  |
| 13.0                             | 810              | 0.0621        | Green   |

Variation in birefringence was also found within a single fiber, as shown in Table 3 below, which is from a study of two fibers from the web of Example 4.

20

Table 3

| Fiber   | Position | Birefringence (Levy) | Birefringence difference (a)% | Birefringence (Berek) | Birefringence difference (b) % |
|---------|----------|----------------------|-------------------------------|-----------------------|--------------------------------|
| Fiber 1 | 1        | 0.037                | 48                            | 0.0468                | 63                             |
|         | 2        | 0.019                |                               | 0.0173                |                                |
| Fiber 2 | 1        | 0.066                | 56                            | 0.0725                | 62                             |
|         | 2        | 0.029                |                               | 0.0271                |                                |

Examples 5-8

Fibrous webs were prepared on apparatus as shown in Figures 1-3 from polybutyl terephthalate (PBT-1 supplied by Ticona; density of 1.31 g/cc, melting point 227 ° C, and glass transition temperature 66 ° C). The extruder temperature was set at 245 ° C and the die temperature was 240 ° C. The polymer flow rate was 1 gram per hole per minute. The distance between the die and attenuator was 14 inches (about 36 centimeters), and the attenuator to collector distance was 16 (about 41 centimeters). Further conditions are stated in Table 4 and other parameters were generally as given for Examples 1-4.

Table 4

| Example No. | Attenuator Gap Top (mm) | Attenuator Gap Bottom (mm) | Attenuator Air Flow (ACMM) |
|-------------|-------------------------|----------------------------|----------------------------|
| 5           | 6.83                    | 4.34                       | 2.83                       |
| 6           | 4.57                    | 4.37                       | 4.59                       |
| 7           | 4.57                    | 3.91                       | 4.05                       |
| 8           | 7.75                    | 5.54                       | 2.86                       |

The webs were collected in an unbonded condition and then passed through an oven at 220 ° C for one minute. Figure 8 is an SEM at 500X showing bonds in a web of Example 5.

Birefringence was studied, with a range and average birefringence for the different examples as shown in Figure 9. Through these studies, variation in morphology was found between fibers and within fibers.

Examples 9-14

Webs of polytrimethylene terephthalate (PTT) fibers were prepared on apparatus as shown in Figures 1-3 using (in Examples 9-11) a clear version of the PTT (CP509201 supplied by Shell Chemicals) and (in Examples 12-14) a version that contained 0.4% TiO<sub>2</sub> (CP509211). The extrusion die was as described in Examples 1-4 and was heated to a temperature as listed in Table 5 below. The polymer flow rate was 1.0 g/hole/minute.

Table 5

| Example No. | Die/Extruder Temperature | Attenuator Gap Top | Attenuator Gap Bottom | Attenuator Air Flow |
|-------------|--------------------------|--------------------|-----------------------|---------------------|
|-------------|--------------------------|--------------------|-----------------------|---------------------|

|    | (°C) | (mm) | (mm) | (ACMM) |
|----|------|------|------|--------|
| 9  | 260  | 3.86 | 3.20 | 1.73   |
| 10 | 265  | 3.86 | 3.20 | 2.49   |
| 11 | 265  | 3.68 | 3.02 | 4.81   |
| 12 | 265  | 3.28 | 2.82 | 3.82   |
| 13 | 265  | 3.28 | 2.82 | 4.50   |
| 14 | 260  | 4.50 | 3.78 | 1.95   |

The distance between the die and attenuator (dimension 17 in Figure 2) was 15 inches (about 38 centimeters), and the distance from the attenuator to the collector (dimension 21 in Figure 2) was 26 inches (about 66 centimeters). Other parameters were as given in Examples 1-4 or as described in Table 5. Webs were collected in an unbonded condition on a nylon spunbond (Cerex) scrim, and then passed in line on the collector through a hot-air knife for bonding.

Birefringence studies for Examples 9-11 produced results as shown in Figure 10. A randomly selected fiber of 14-micrometer diameter showed a difference in birefringence from 0.0517 to 0.041 (determined by a color chart) just a few millimeters apart.

#### Example 15

Fibers of polylactic acid (Grade 625OD supplied by Cargill-Dow) were produced on apparatus as shown in Figures 1-3 and on a die and attenuator as described in Examples 1-4, except as follows. The temperatures of the extruder and die were set at 240 degrees C. The distance between the die and attenuator was 12 inches (about 30.5 centimeters) and between the attenuator and collector was 25 inches (63.5 centimeters). The top gap in the attenuator was 0.168 inch (4.267mm) and the bottom gap was 0.119 inch (3.023mm). The collected web was bonded in an oven at 55 ° C for 10 minutes. The fibers in the web exhibited varying morphology and were autogenously bonded.

#### Example 16

Apparatus as pictured in Figs. 1-3 was used to prepare fibrous webs from polypropylene (Fina 3860) having a melt flow index of 70. Parameters were generally as described for Examples 1-4, except that the polymer flow rate was 0.5 g/hole/minute, the die had 168 orifices of 0.343 mm diameter, with an orifice L/D ratio of 3.5, the attenuator



gap was 7.67 mm at the top and bottom, and the die to attenuator distance was 108 mm and the attenuator to collector distance was 991 mm.

The web was bonded using a hot-air knife in which the air was heated to 166 ° C and had a face velocity greater than 100 meters/minute.

5 To illustrate the variation in morphology exhibited along the length of the fibers, a gravimetric analysis was performed using the Test for Density Gradation Along Fiber Length described above. The column contained a mixture of methanol and water. Results are given in Table 6 for the free fiber pieces in the tube, giving the location of a particular fiber piece (midpoint of the fiber) along the height of the tube in centimeters, the angle of  
10 the fiber piece, and the calculated average or overall density for the fiber piece.

Table 6

| Height of Fiber Midpoint | Angle in Column (degrees from Horizontal) | Fiber Piece Density (g/cc) |
|--------------------------|---|----------------------------|
| 53.15                    | 90  | 0.902515                   |
| 53.24                    | 90  | 0.902344                   |
| 52.06                    | 65  | 0.904586                   |
| 51.65                    | 90  | 0.905365                   |
| 52.13                    | 85  | 0.904453                   |
| 53.30                    | 90  | 0.90223                    |
| 53.66                    | 90  | 0.901546                   |
| 52.47                    | 80  | 0.903807                   |
| 51.88                    | 85  | 0.904928                   |
| 52.94                    | 85  | 0.902914                   |
| 51.70                    | 90  | 0.90527                    |

15 The average of the angles at which the fiber pieces were disposed was 85.5 degrees and the median of those angles was 90 °.

#### Example 17

Fibrous webs were produced from a nylon 6 resin (Ultramid B3 supplied by BASF) using apparatus as shown in Figures 1-3 and a die as described in Examples 1-4. The temperatures of the extruder and die were set at 270 degrees C. The polymer flow  
20 rate was 1.0g/hole/minute. The distance between the die and attenuator was 13 inches (about 33 centimeters) and between the attenuator and collector was 25 inches (63.5 centimeters). The top gap in the attenuator was 0.135 inch (3.429mm) and the bottom gap was 0.112 inch (2.845mm). Chute length was 167.4 millimeters. Air flow through the

attenuator was 142 SCFM (4.021 ACMM). The collected web was bonded in line on the collector with a hot-air knife using air at a temperature of 220 ° C and a face velocity greater than 100 meters/minute.

Under a polarized microscope the webs revealed different degrees of orientation along the fibers and between fibers. Portions of fibers showing a variation of birefringence along their length were identified and the birefringence at two locations was measured using the Michel Levy chart and the Berek Compensator technique. Results are reported in Table 7.

Table 7

| Fiber   | Position | Birefringence (Levy) | Birefringence difference (a)% | Birefringence (Berek) | Birefringence difference (b) % |
|---------|----------|----------------------|-------------------------------|-----------------------|--------------------------------|
| Fiber 1 | 1        | 0.037                | 10.8                          | 0.042                 | 33.3                           |
|         | 2        | 0.033                |                               | 0.028                 |                                |
| Fiber 2 | 1        | 0.040                | 10.0                          | 0.041                 | 19.5                           |
|         | 2        | 0.036                |                               | 0.033                 |                                |

Example 18

Nonwoven fibrous webs were prepared from polyurethane (Morton PS-440-200, MFI of 37) using apparatus of Figures 1-3, with an extrusion die as described for Examples 1-4. The polymer throughput was 1.98 g/hole/minute. The attenuator, basically as described for Examples 1-4, had a 0.196-inch (4.978mm) gap at the top and a 0.179-inch (4.547mm) gap at the bottom. The volume of air passed through the attenuator was greater than 3 ACMM. The attenuator was 12.5 inches (31.75cm) below the die and 24 inches (about 61cm) above the collector. The webs, which comprised fibers averaging 14.77 micrometers in diameter, were self-bonded as collected, and no further bonding step was needed or performed.

Using a polarized microscope, variation in morphology/orientation could be seen between fibers of the same sample and along the same fiber. Portions of fibers that exhibited a variation in birefringence along the fiber were identified and birefringence at two locations was measured using the Michel Levy chart and the Berek Compensator technique. Results are shown in Table 8.

Table 8

| Fiber   | Position | Birefringence (Levy) | Birefringence difference (a)% | Birefringence (Berek) | Birefringence difference (b) % |
|---------|----------|----------------------|-------------------------------|-----------------------|--------------------------------|
| Fiber 1 | 1        | 0.040                | 22.5                          | 0.042                 | 33.3                           |
|         | 2        | 0.031                |                               | 0.028                 |                                |
| Fiber 2 | 1        | 0.036                | 11.1                          | 0.0375                | 28.8                           |
|         | 2        | 0.032                |                               | 0.0267                |                                |

Variations in morphology were also examined using the Test for Density Gradation  
 5 Along Fiber Length, using a mixture of methanol and water, with results as shown in Table 9.

Table 9

| Angle in Column (degrees from Horizontal) |
|---|
| 65  |
| 90  |
| 75  |
| 80  |
| 70  |
| 85  |
| 90  |
| 90  |
| 85  |
| 85  |
| 45  |
| 90  |
| 90  |
| 60  |
| 75  |
| 80  |
| 90  |
| 90  |
| 70  |
| 80  |

10 The average angle was 79.25 ° and the median angle was 82.5 °.

Example 19

Polyethylene nonwoven fibrous webs were prepared from polyethylene having a MFI of 30 and density of 0.95 (Dow 6806) using apparatus as shown in Figures 1-3 and an extrusion die as described for Examples 1-4. The extruder and die temperature were set at 180 ° C. The throughput was 1.0 g/hole/minute. The attenuator, basically as described in Examples 1-4, was placed 15 inches (about 38 centimeters) below the die and 20 inches (about 51 centimeters) above the collector. The attenuator gap was 0.123 inch (3.124mm) at the top and 0.11 inch (2.794mm) at the bottom. The air flow through the attenuator was 113 SCFM (3.2 ACMM). Collected webs were bonded with a hot-air knife using air at a temperature of 135 degrees C and a face velocity of greater than 100 meters/minute.

Portions of fibers that exhibited a variation in birefringence along the fiber were identified and the birefringence at two locations on the fiber were measured using the Michel Levy chart and the Berek Compensator technique. Results are given in Table 10.

Table 10

| Fiber   | Position | Birefringence (Levy) | Birefringence difference (a)% | Birefringence (Berek) | Birefringence difference (b) % |
|---------|----------|----------------------|-------------------------------|-----------------------|--------------------------------|
| Fiber 1 | 1        | 0.0274               | 15.7                          | 0.0240                | 33.3                           |
|         | 2        | 0.0325               |                               | 0.0328                |                                |
| Fiber 2 | 1        | 0.036                | 8.3                           | Na                    | Na                             |
|         | 2        | 0.033                |                               | Na                    |                                |

Example 20

Example 19 was repeated except that the die had 168 orifices, the diameter of the orifices was 0.508 millimeters, the attenuator gap was 3.20 millimeters at the top and 2.49 millimeters at the bottom, the chute length was 228.6 millimeters, the air flow through the  
 5 attenuator was 2.62 ACMM, and the attenuator to collector distance was about 61 centimeters.

The Test for Density Gradient Along Fiber Length was conducted using a mixture of methanol and water, with results as shown in Table 11.

10

Table 11

| Height of Fiber Midpoint | Angle in Column (Degrees from Horizontal) | Fiber Piece Density (g/cc) |
|--------------------------|---|----------------------------|
| 41.5                     | 80  | 0.92465                    |
| 40.6                     | 85  | 0.92636                    |
| 42.5                     | 30  | 0.92275                    |
| 37.5                     | 90  | 0.93225                    |
| 40.3                     | 90  | 0.92693                    |
| 40.2                     | 70  | 0.92712                    |
| 40.7                     | 80  | 0.92617                    |
| 42.1                     | 70  | 0.92351                    |
| 42.4                     | 80  | 0.92294                    |
| 40.9                     | 90  | 0.92579                    |

The average angle in the test was 76.5° and the median angle was 80°.

Example 21

15

Apparatus as shown in Figures 1-3 was used to prepare amorphous polymeric fibers using cyclic-olefin polymer (TOPAS 6017 from Ticona). The polymer was heated to 320°C in the extruder (temperature measured in the extruder 12 near the exit to the pump 13), and the die was heated to a temperature of 320°C. The extrusion head or die had four rows, and each row had 42 orifices, making a total of 168 orifices. The die had a  
 20 transverse length of 4 inches (102 millimeters (mm)). The orifice diameter was 0.020 inch (0.51 mm) and the L/D ratio was 6.25. The polymer flow rate was 1.0 g/orifice/minute.

The distance between the die and attenuator (dimension 17 in Figure 1) was 33 inches (about 84 centimeters), and the distance from the attenuator to the collector

(dimension 21 in Figure 1) was 24 inches (about 61 centimeters). The air knife gap (the dimension 30 in Figure 2) was 0.030 inch (0.762 millimeter); the attenuator body angle ( $\alpha$  in Figure 2) was 30°; room temperature air was passed through the attenuator; and the length of the attenuator chute (dimension 35 in Figure 2) was 6.6 inches (168 millimeters).  
 5 The air knife had a transverse length (the direction of the length 25 of the slot in Figure 3) of about 120 millimeters; and the attenuator body 28 in which the recess for the air knife was formed had a transverse length of about 152 millimeters. The transverse length of the wall 36 attached to the attenuator body was 5 inches (127 millimeters).

The attenuator gap at the top was 1.6 mm (dimension 33 in Figure 2). The  
 10 attenuator gap at the bottom was 1.7 mm (dimension 34 in Figure 2). The total volume of air passed through the attenuator was 3.62 Actual Cubic Meters per Minute (ACMM); with about half of the volume passing through each air knife 32.

Fibrous webs were collected on a conventional porous web-forming collector in an unbonded condition. The webs were then heated in an oven at 300°C for 1 minute. The  
 15 latter step caused autogenous bonding within the webs as illustrated in Figure 11 (a micrograph taken at a magnification of 200X using a Scanning Electron Microscope). As can be seen, the autogeneously bonded amorphous polymeric fibers retain their fibrous shape after bonding.

To illustrate the variation in morphology exhibited along the length of the fibers, a  
 20 gravimetric analysis was performed using the Graded Density test described above. The column contained a water-calcium nitrate solution mixture according to ASTM D1505-85. Results for twenty pieces moving from top to bottom within the column are given in Table 12.

Table 12

| Angle in Column<br>(degrees from Horizontal) |
|--|
| 80   |
| 90   |
| 85   |
| 85   |
| 90   |
| 80   |
| 85   |
| 80   |
| 90   |

|    |
|----|
| 85 |
| 85 |
| 90 |
| 80 |
| 90 |
| 85 |
| 85 |
| 85 |
| 90 |
| 90 |
| 80 |

The average angle of the fibers was 85.5 degrees, the median was 85 degrees.

#### Example 22

5 Apparatus as shown in Figures 1-3 was used to prepare amorphous polymeric fibers using polystyrene (Crystal PS 3510 from Nova Chemicals) having Melt Flow Index of 15.5 and density of 1.04. The polymer was heated to 268°C in the extruder (temperature measured in the extruder 12 near the exit to the pump 13), and the die was heated to a temperature of 268°C. The extrusion head or die had four rows, and each row had 42 orifices, making a total of 168 orifices. The die had a transverse length of 4 inches  
10 (102 millimeters). The orifice diameter was 0.343 mm and the L/D ratio was 9.26. The polymer flow rate was 1.00 g/orifice/minute.

The distance between the die and attenuator (dimension 17 in Figure 1) was about 318 millimeters, and the distance from the attenuator to the collector (dimension 21 in  
15 Figure 1) was 610 millimeters. The air knife gap (the dimension 30 in Figure 2) was 0.76 millimeter; the attenuator body angle ( $\alpha$  in Figure 2) was 30°; air with a temperature of 25 degrees Celsius was passed through the attenuator; and the length of the attenuator chute (dimension 35 in Figure 2) was (152 millimeters). The air knife had a transverse length (the direction of the length 25 of the slot in Figure 3) of about 120 millimeters; and the  
20 attenuator body 28 in which the recess for the air knife was formed had a transverse length of 152 millimeters. The transverse length of the wall 36 attached to the attenuator body was 5 inches (127 millimeters).

The attenuator gap at the top was 4.4 mm (dimension 33 in Figure 2). The attenuator gap at the bottom was 3.1 mm (dimension 34 in Figure 2). The total volume of

air passed through the attenuator was 2.19 ACMM (Actual Cubic Meters per Minute); with about half of the volume passing through each air knife 32.

Fibrous webs were collected on a conventional porous web-forming collector in an unbonded condition. The webs were then heated in an oven at 200°C for 1 minute. The latter step caused autogenous bonding within the webs, with the autogeneously bonded amorphous polymeric fibers retaining their fibrous shape after bonding.

To illustrate the variation in morphology exhibited along the length of the fibers, a gravimetric analysis was performed using the Graded Density test described above. The column contained a mixture of water and calcium nitrate solution. Results for twenty pieces moving from top to bottom within the column are given in Table 13.

Table 13

| Angle in Column<br>(degrees from Horizontal) |
|--|
| 85   |
| 75   |
| 90   |
| 70   |
| 75   |
| 90   |
| 80   |
| 90   |
| 75   |
| 85   |
| 80   |
| 90   |
| 90   |
| 75   |
| 90   |
| 85   |
| 75   |
| 80   |
| 90   |
| 90   |

The average angle of the fibers was 83 degrees, the median was 85 degrees.



### Example 23

Apparatus as shown in Figures 1-3 was used to prepare amorphous polymeric fibers using a block copolymer with 13 percent styrene and 87 percent ethylene butylene copolymer (KRATON G1657 from Shell) with a Melt Flow Index of 8 and density of 0.9.

5 The polymer was heated to 275°C in the extruder (temperature measured in the extruder 12 near the exit to the pump 13), and the die was heated to a temperature of 275°C. The extrusion head or die had four rows, and each row had 42 orifices, making a total of 168 orifices. The die had a transverse length of 4 inches (101.6 millimeters). The orifice diameter was 0.508 mm and the L/D ratio was 6.25. The polymer flow rate was 0.64  
10 g/orifice/minute.

The distance between the die and attenuator (dimension 17 in Figure 1) was 667 millimeters, and the distance from the attenuator to the collector (dimension 21 in Figure 1) was 330 millimeters. The air knife gap (the dimension 30 in Figure 2) was 0.76 millimeter; the attenuator body angle ( $\alpha$  in Figure 2) was 30°; air with a temperature of 25  
15 degrees Celsius was passed through the attenuator; and the length of the attenuator chute (dimension 35 in Figure 2) was 76 millimeters. The air knife had a transverse length (the direction of the length 25 of the slot in Figure 3) of about 120 millimeters; and the attenuator body 28 in which the recess for the air knife was formed had a transverse length of about 152 millimeters. The transverse length of the wall 36 attached to the attenuator  
20 body was 5 inches (127 millimeters).

The attenuator gap at the top was 7.6 mm (dimension 33 in Figure 2). The attenuator gap at the bottom was 7.2 mm (dimension 34 in Figure 2). The total volume of air passed through the attenuator was 0.41 ACMM (Actual Cubic Meters per Minute); with about half of the volume passing through each air knife 32.

25 Fibrous webs were collected on a conventional porous web-forming collector, with the fibers autogenously bonding as the fibers were collected. The autogenously bonded amorphous polymeric fibers retained their fibrous shape after bonding.

To illustrate the variation in morphology exhibited along the length of the fibers, a gravimetric analysis was performed using the Graded Density test described above. The  
30 column contained a mixture of methanol and water. Results for twenty pieces moving from top to bottom within the column are given in Table 14.

Table 14

| Angle in Column<br>(degrees from Horizontal) |
|--|
| 55   |
| 45   |
| 50   |
| 30   |
| 45   |
| 45   |
| 50   |
| 35   |
| 40   |
| 55   |
| 55   |
| 40   |
| 45   |
| 55   |
| 40   |
| 35   |
| 35   |
| 40   |
| 50   |
| 55   |

The average angle of the fibers was 45 degrees, the median was 45 degrees.

5

Example 24

Apparatus as shown in Figures 1-3 was used to prepare amorphous polymeric fibers using polycarbonate (General Electric SLCC HF 1110P resin). The polymer was heated to 300°C in the extruder (temperature measured in the extruder 12 near the exit to the pump 13), and the die was heated to a temperature of 300°C. The extrusion head or die had four rows, and each row had 21 orifices, making a total of 84 orifices. The die had a transverse length of 4 inches (102 millimeters). The orifice diameter was 0.035 inch (0.889 mm) and the L/D ratio was 3.5. The polymer flow rate was 2.7 g/orifice/minute.

10

The distance between the die and attenuator (dimension 17 in Figure 1) was 15 inches (about 38 centimeters), and the distance from the attenuator to the collector (dimension 21 in Figure 1) was 28 inches (71.1 centimeters). The air knife gap (the dimension 30 in Figure 2) was 0.030 inch (0.76 millimeter); the attenuator body angle ( $\alpha$

15

in Figure 2) was 30°; room temperature air was passed through the attenuator; and the length of the attenuator chute (dimension 35 in Figure 2) was 6.6 inches (168 millimeters). The air knife had a transverse length (the direction of the length 25 of the slot in Figure 3) of about 120 millimeters; and the attenuator body 28 in which the recess for the air knife  
5 was formed had a transverse length of about 152 millimeters. The transverse length of the wall 36 attached to the attenuator body was 5 inches (127 millimeters).

The attenuator gap at the top was 0.07 (1.8 mm) (dimension 33 in Figure 2). The attenuator gap at the bottom was 0.07 inch (1.8 mm) (dimension 34 in Figure 2). The total volume of air passed through the attenuator (given in actual cubic meters per minute, or  
10 ACMM) was 3.11; with about half of the volume passing through each air knife 32.

Fibrous webs were collected on a conventional porous web-forming collector in an unbonded condition. The webs were then heated in an oven at 200°C for 1 minute. The latter step caused autogenous bonding within the webs, with the autogeneously bonded amorphous polymeric fibers retaining their fibrous shape after bonding.

15 To illustrate the variation in morphology exhibited along the length of the fibers, a gravimetric analysis was performed using the Graded Density test described above. The column contained a mixture of water and calcium nitrate solution. Results for twenty pieces moving from top to bottom within the column are given in Table 15.

Table 15

| Angle in Column<br>(degrees from Horizontal) |
|--|
| 90   |
| 90   |
| 90   |
| 85   |
| 90   |
| 90   |
| 90   |
| 90   |
| 85   |
| 90   |
| 90   |
| 85   |
| 90   |
| 90   |
| 90   |
| 90   |
| 90   |
| 85   |
| 90   |
| 90   |

The average angle of the fibers was 89 degrees, the median was 90 degrees.

5

Example 25

Apparatus as shown in Figures 1-3 was used to prepare amorphous polymeric fibers using polystyrene (BASF Polystyrene 145D resin). The polymer was heated to 245°C in the extruder (temperature measured in the extruder 12 near the exit to the pump 13), and the die was heated to a temperature of 245°C. The extrusion head or die had four rows, and each row had 21 orifices, making a total of 84 orifices. The die had a transverse length of 4 inches (101.6 millimeters). The orifice diameter was 0.035 inch (0.889 mm) and the L/D ratio was 3.5. The polymer flow rate was 0.5 g/orifice/minute.

The distance between the die and attenuator (dimension 17 in Figure 1) was 15 inches (about 38 centimeters), and the distance from the attenuator to the collector (dimension 21 in Figure 1) was 25 inches (63.5 centimeters). The air knife gap (the dimension 30 in Figure 2) was 0.030 inch (0.762 millimeter); the attenuator body angle ( $\alpha$

in Figure 2) was 30°; room temperature air was passed through the attenuator; and the length of the attenuator chute (dimension 35 in Figure 2) was 6.6 inches (167.64 millimeters). The air knife had a transverse length (the direction of the length 25 of the slot in Figure 3) of about 120 millimeters; and the attenuator body 28 in which the recess  
5 for the air knife was formed had a transverse length of about 152 millimeters. The transverse length of the wall 36 attached to the attenuator body was 5 inches (127 millimeters).

The attenuator gap at the top was 0.147 inch (3.73 mm) (dimension 33 in Figure 2). The attenuator gap at the bottom was 0.161 inch (4.10 mm) (dimension 34 in Figure  
10 2). The total volume of air passed through the attenuator (given in actual cubic meters per minute, or ACMM) was 3.11, with about half of the volume passing through each air knife 32.

Fibrous webs were collected on a conventional porous web-forming collector in an unbonded condition. The webs were then heated in a through-air bonder at 100°C for 1  
15 minute. The latter step caused autogenous bonding within the webs, with the autogeneously bonded amorphous polymeric fibers retaining their fibrous shape after bonding.

Testing using a TA Instruments Q1000 Differential Scanning Calorimeter was conducted to determine the effect of processing on the glass transition range of the  
20 polymer. A linear heating rate of 5°C per minute was applied to each sample, with a perturbation amplitude of  $\pm 1^\circ\text{C}$  every 60 seconds. The samples were subjected to a heat-cool-heat profile ranging from 0°C to about 150°C.

The results of testing on the bulk polymer, i.e., polymer that is not formed into fibers and the polymers formed into fibers (before and after simulated bonding) are  
25 depicted in Figure 12. It can be seen that, within the glass transition range, the onset temperature of the fibers before simulated bonding is lower than the onset temperature of the bulk polymer. Also, the end temperature of the glass transition range for the fibers before simulated bonding is higher than the end temperature of the bulk polymer. As a result, the glass transition range of the amorphous polymeric fibers is larger than the glass  
30 transition range of the bulk polymer.

The preceding specific embodiments are illustrative of the practice of the invention. This invention may be suitably practiced in the absence of any element or item not

specifically described in this document. The complete disclosures of all patents, patent applications, and publications are incorporated into this document by reference as if individually incorporated. Various modifications and alterations of this invention will become apparent to those skilled in the art without departing from the scope of this invention. It should be understood that this invention is not to be unduly limited to illustrative embodiments set forth herein.

What is claimed is:

1. A bonded nonwoven fibrous web comprising a directly collected mass of fibers of uniform diameter that vary in morphology along their length so as to provide longitudinal segments of distinctive softening characteristics during a selected bonding operation, some segments softening under the conditions of the bonding operation and bonding to other fibers of the web and other segments being passive during the bonding operation.
2. A fibrous web of claim 1 in which the fibers that vary in morphology comprise segments that exhibit chain-extended crystallization.
3. A web of claim 1 or 2 bonded by autogenous bonding.
4. A fibrous web of claim 3 in which the bonds comprise circumference-penetrating bonds with other fibers.
5. A web of any of claims 1-4 in which the fibers that vary in morphology include longitudinal segments that differ in birefringence by at least 5%.
6. A web of any of claims 1-5 in which the fibers that vary in morphology include longitudinal segments that differ in birefringence by at least 10%.
7. A web of any of claims 1-6, wherein, in the Graded Density test described herein, at least five fiber pieces of said fibers become disposed at an angle at least 30 degrees from horizontal.
8. A web of any of claims 1-6, wherein, in the Graded Density test described herein, at least five fiber pieces of said fibers become disposed at an angle at least 60 degrees from horizontal.

9. A web of any of claims 1-6, wherein, in the Graded Density test described herein, at least half the fiber pieces of said fibers become disposed at an angle at least 30 degrees from horizontal.

5 10. A web of any of claims 1-6, wherein, in the Graded Density test described herein, at least half the fiber pieces of said fibers that vary in morphology become disposed at an angle at least 60 degrees from horizontal.

10 11. A web of any of claims 1-10 in which the fibers that vary in morphology have an average diameter of about 10 micrometers or less.

12. A web of any of claims 1-11 having a loft of at least 90 percent solidity.

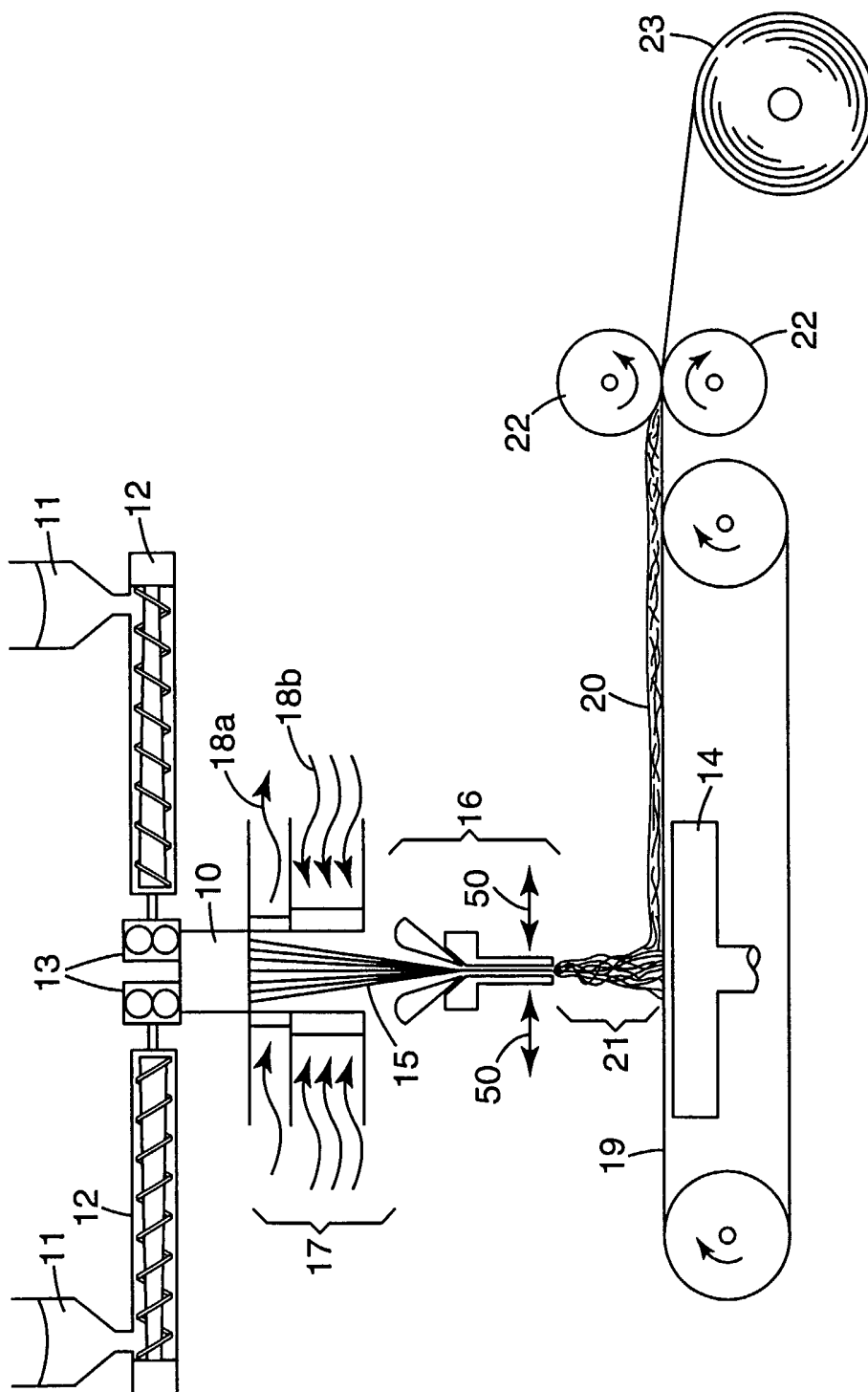
15 13. A web of any of claims 1-12 that includes other fibers in addition to those that vary in morphology.

20 14. A fiber-forming method comprising a) extruding filaments of fiber-forming material; b) directing the filaments through a processing chamber in which gaseous currents apply a longitudinal stress to the filaments; c) subjecting the filaments to turbulent flow conditions after they exit the processing chamber; and d) collecting the processed filaments; the temperature of the filaments being controlled so that at least some of the filaments solidify while in the turbulent field.

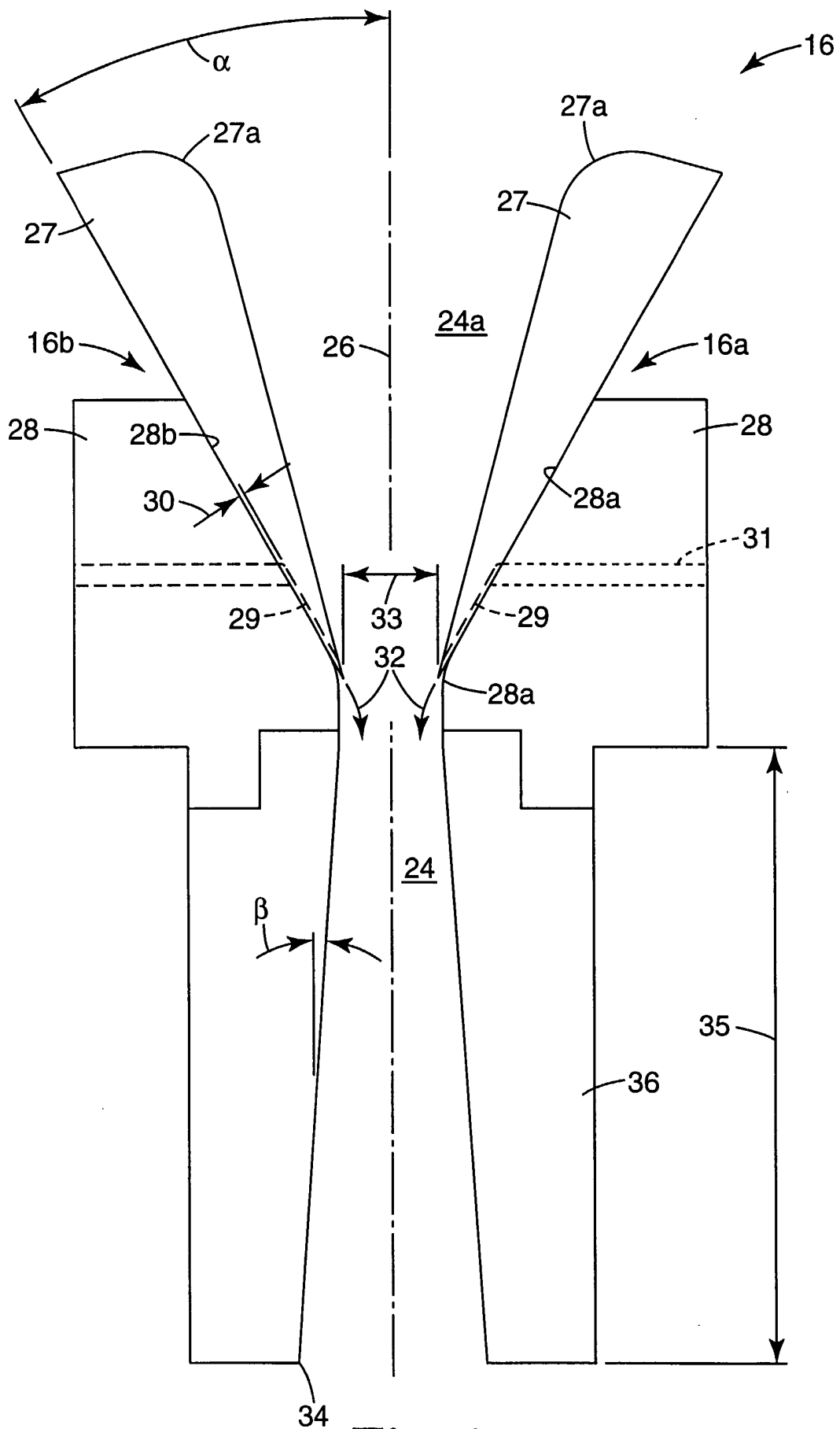
25 15. A method of claim 14 in which the fibers are collected as a nonwoven fibrous web and subjected to a bonding operation during which some longitudinal segments of the fibers soften and bond to other fibers while other longitudinal segments remain passive during the bonding operation.

30 16. A method of claim 14 in which the fibers are collected as a nonwoven fibrous web and subjected to an autogenous bonding operation, during which some longitudinal segments of the fibers soften and bond to other fibers while other longitudinal segments remain passive during the bonding operation.

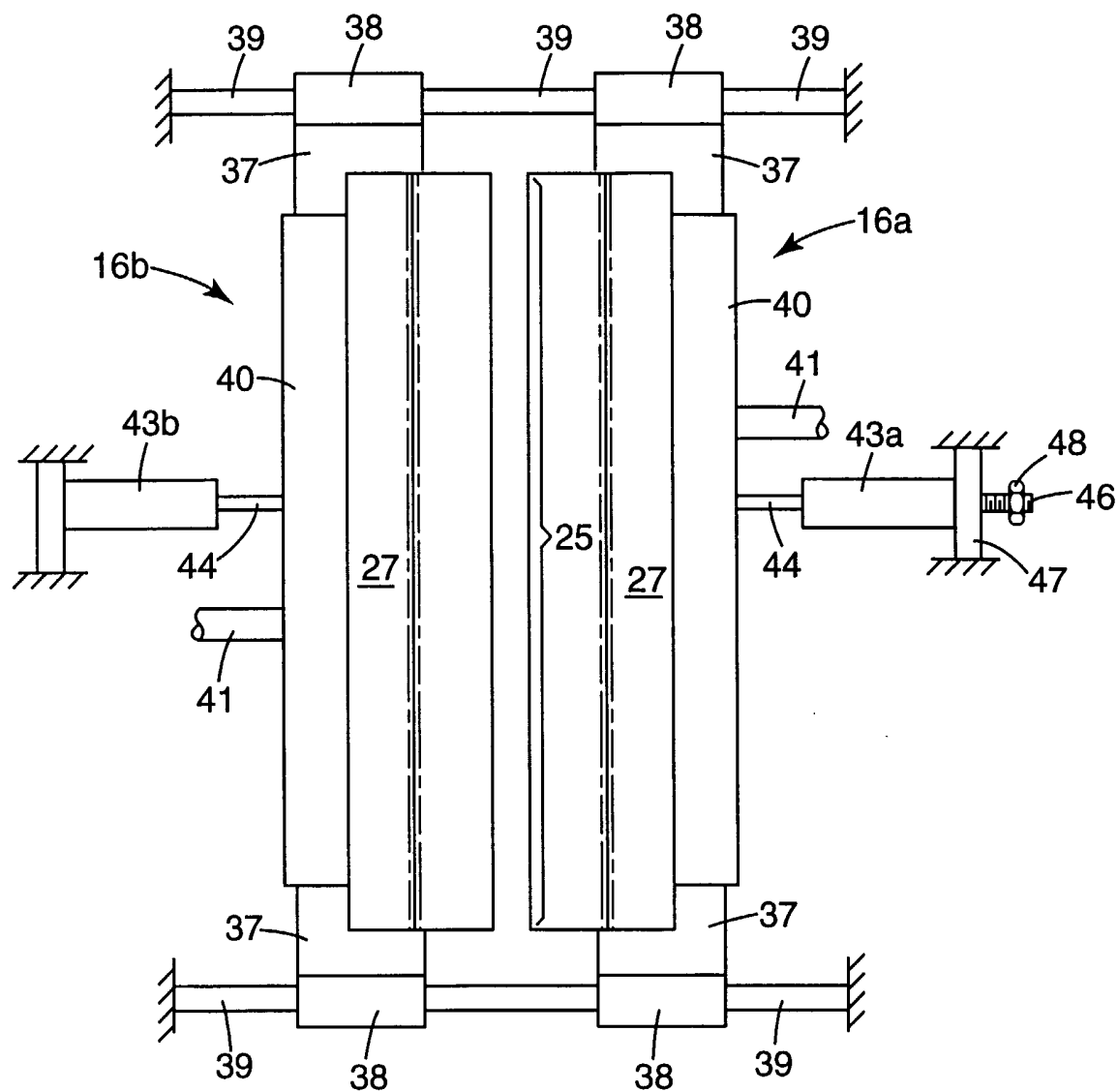




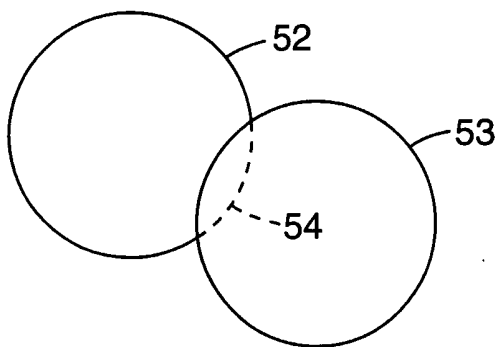
**Fig. 1**



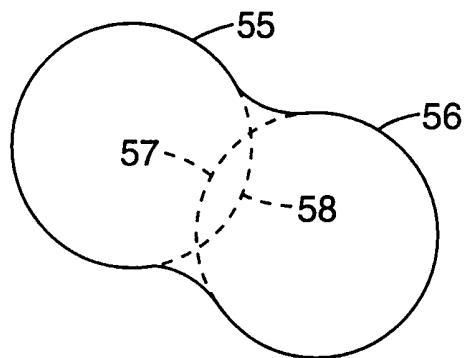
**Fig. 2**



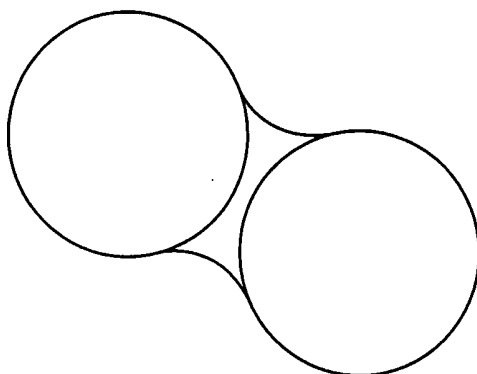
**Fig. 3**



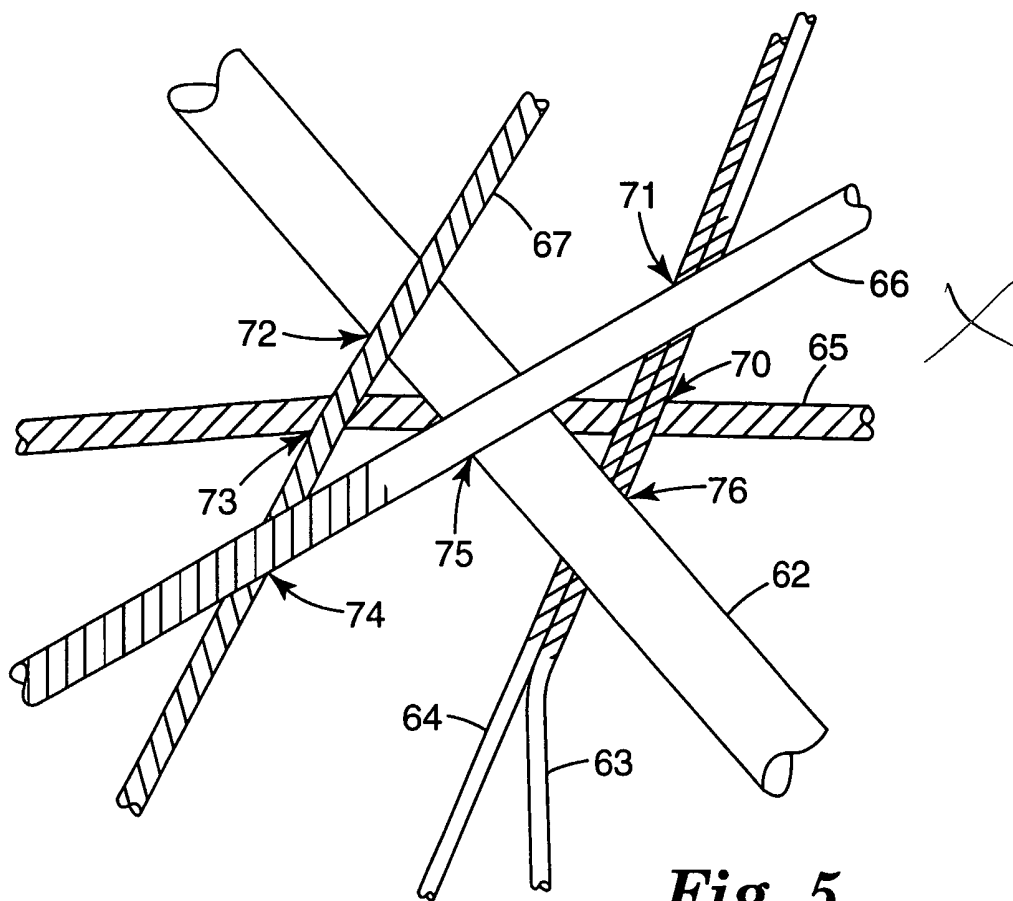
**Fig. 4a**



**Fig. 4b**



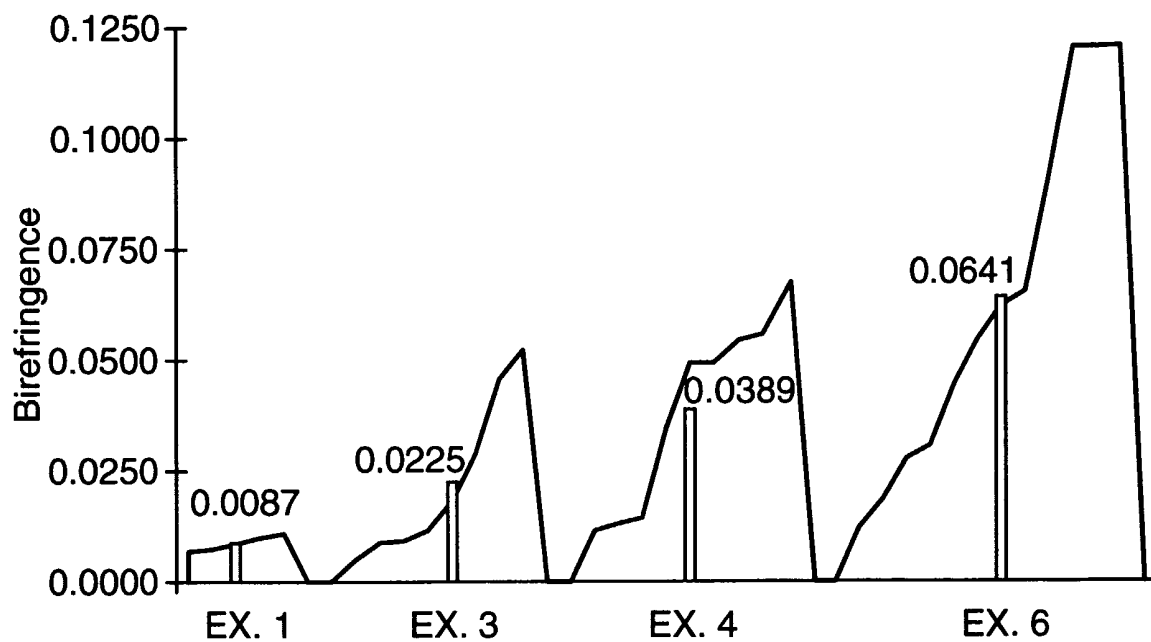
**Fig. 4c**



**Fig. 5**



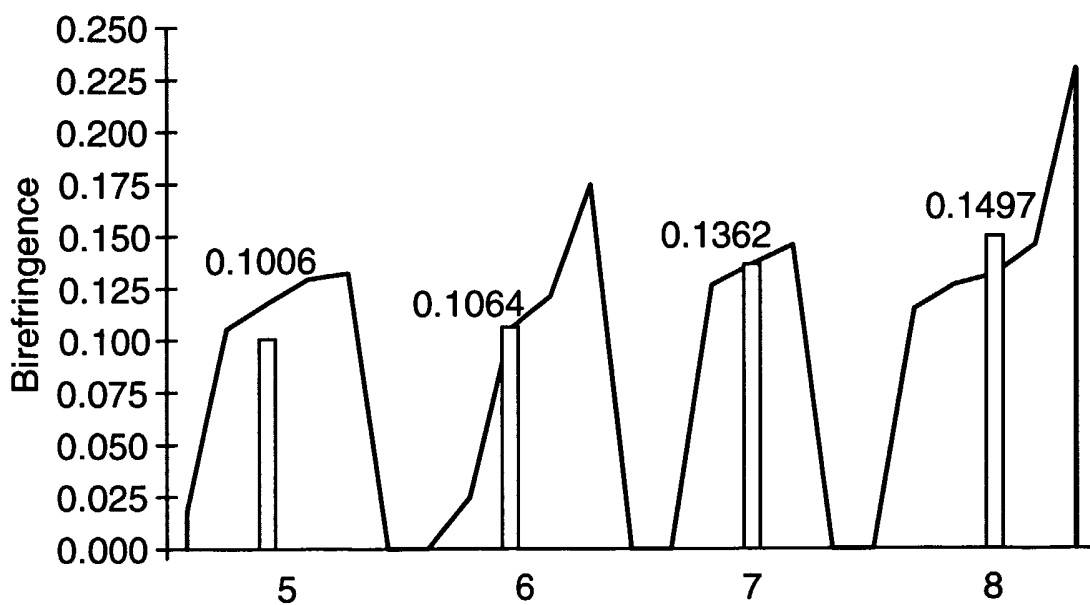
*Fig. 6*



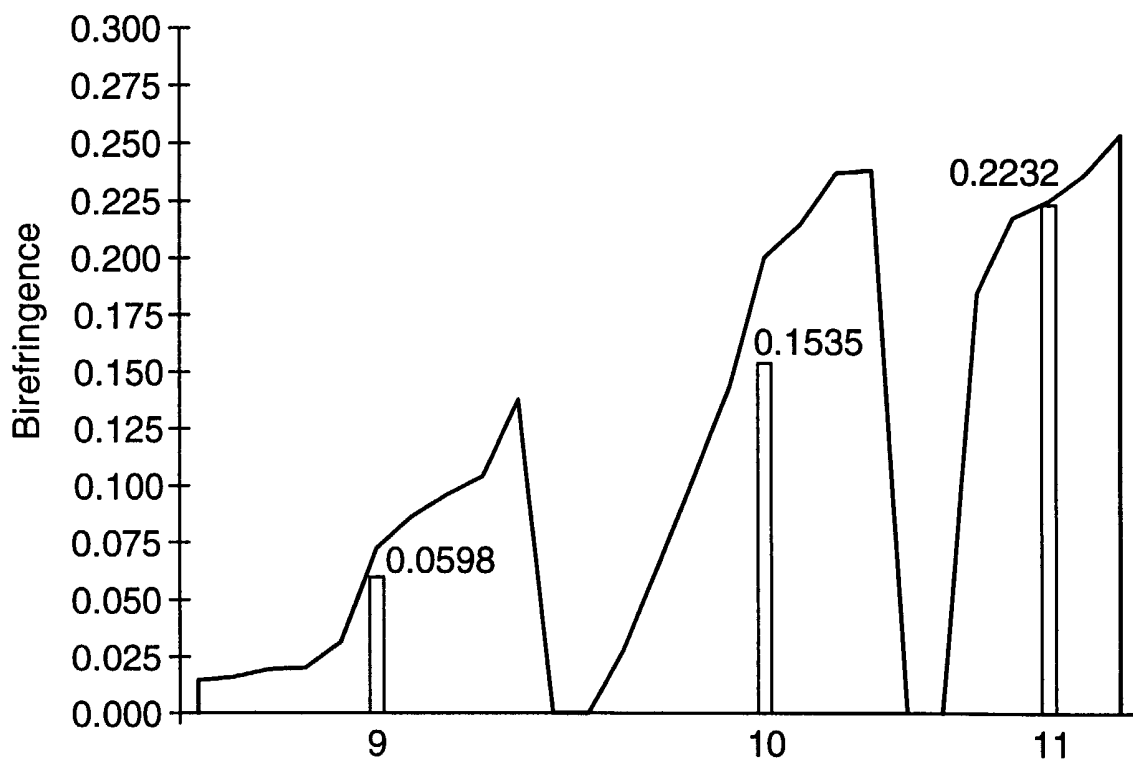
*Fig. 7*



*Fig. 8*



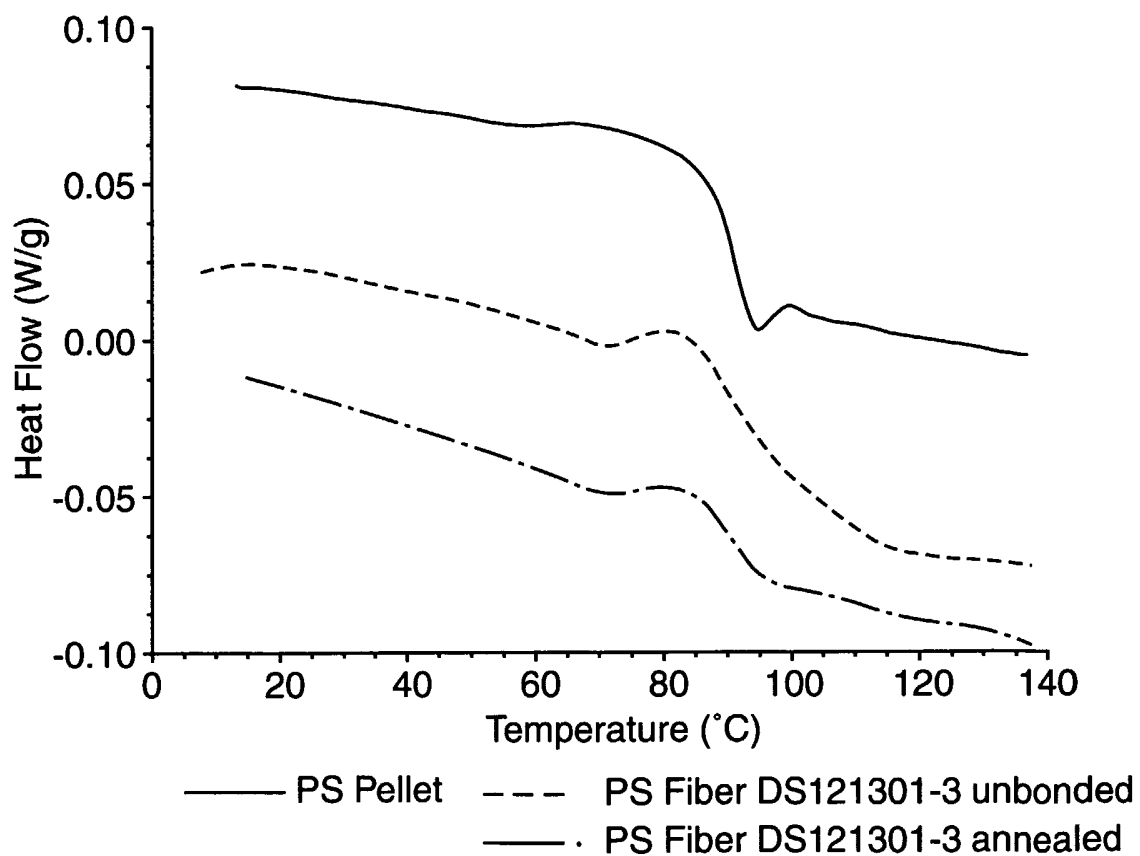
*Fig. 9*



*Fig. 10*



*Fig. 11*



*Fig. 12*



INTERNATIONAL SEARCH REPORT

International Application No  
PCT/US 03/11566

**A. CLASSIFICATION OF SUBJECT MATTER**  
IPC 7 D01D5/098 D04H3/03 D04H3/16

According to International Patent Classification (IPC) or to both national classification and IPC

**B. FIELDS SEARCHED**  
Minimum documentation searched (classification system followed by classification symbols)  
IPC 7 D01D D04H

Documentation searched other than minimum documentation to the extent that such documents are included in the fields searched

Electronic data base consulted during the international search (name of data base and, where practical, search terms used)  
EPO-Internal, WPI Data, PAJ

**C. DOCUMENTS CONSIDERED TO BE RELEVANT**

| Category * | Citation of document, with indication, where appropriate, of the relevant passages  | Relevant to claim No. |
|------------|---|-----------------------|
| X          | US 4 086 381 A (CHESHIRE DAVID ALAN ET AL)<br>25 April 1978 (1978-04-25)<br>cited in the application<br>column 3, line 21 -column 4, line 46;<br>figure 1 | 1-6,11,<br>13         |
| P,X        | WO 02 055782 A (3M INNOVATIVE PROPERTIES<br>CO) 18 July 2002 (2002-07-18)<br>claims 24-31; figures 1-7  | 1-6,11,<br>13         |
| X          | US 6 183 684 B1 (LU FUMIN)<br>6 February 2001 (2001-02-06)<br>column 5, line 11 -column 6, line 48;<br>figures 1,2  | 14                    |
| A          | US 4 147 749 A (LIPSCOMB WALTER P ET AL)<br>3 April 1979 (1979-04-03)<br>column 2, line 5 - line 46; figure 3   | 1-4,11,<br>13         |
|            | -/--  |                       |

Further documents are listed in the continuation of box C.

Patent family members are listed in annex.

\* Special categories of cited documents :

- \*A\* document defining the general state of the art which is not considered to be of particular relevance
- \*E\* earlier document but published on or after the international filing date
- \*L\* document which may throw doubts on priority claim(s) or which is cited to establish the publication date of another citation or other special reason (as specified)
- \*O\* document referring to an oral disclosure, use, exhibition or other means
- \*P\* document published prior to the international filing date but later than the priority date claimed
- \*T\* later document published after the international filing date or priority date and not in conflict with the application but cited to understand the principle or theory underlying the invention
- \*X\* document of particular relevance; the claimed invention cannot be considered novel or cannot be considered to involve an inventive step when the document is taken alone
- \*Y\* document of particular relevance; the claimed invention cannot be considered to involve an inventive step when the document is combined with one or more other such documents, such combination being obvious to a person skilled in the art.
- \*G\* document member of the same patent family

|  |   |
|--|---|
| Date of the actual completion of the international search<br><b>13 August 2003</b> | Date of mailing of the international search report<br><b>19/09/2003</b> |
|--|---|

|  |  |
|--|--|
| Name and mailing address of the ISA<br>European Patent Office, P.B. 5818 Patentlaan 2<br>NL - 2280 HV Rijswijk<br>Tel. (+31-70) 340-2040, Tx. 31 651 epo nl,<br>Fax: (+31-70) 340-3016 | Authorized officer<br><b>Mangin, S</b> |
|--|--|

## INTERNATIONAL SEARCH REPORT

International Application No

PCT/US 03/11566

| C.(Continuation) DOCUMENTS CONSIDERED TO BE RELEVANT |   |                       |
|--|---|-----------------------|
| Category °   | Citation of document, with indication, where appropriate, of the relevant passages  | Relevant to claim No. |
| A  | US 5 296 286 A (ALLEN STEVEN R ET AL)<br>22 March 1994 (1994-03-22)<br>column 1, line 64 -column 2, line 51;<br>figure 3<br>---       | 1-6, 11,<br>13-16     |
| A  | US 4 405 297 A (APPEL DAVID W ET AL)<br>20 September 1983 (1983-09-20)<br>column 2, line 21 -column 3, line 47;<br>figures 2-4<br>--- | 14-16                 |
| A  | US 5 460 500 A (GEUS HANS G ET AL)<br>24 October 1995 (1995-10-24)<br>column 2, line 21 -column 3, line 54;<br>figure 1<br>-----      | 14-16                 |

# INTERNATIONAL SEARCH REPORT

International application No.  
PCT/US 03/11566

## Box I Observations where certain claims were found unsearchable (Continuation of item 1 of first sheet)

This International Search Report has not been established in respect of certain claims under Article 17(2)(a) for the following reasons:

1.  Claims Nos.:  
because they relate to subject matter not required to be searched by this Authority, namely:
  
2.  Claims Nos.: 7-10, 12  
because they relate to parts of the International Application that do not comply with the prescribed requirements to such an extent that no meaningful International Search can be carried out, specifically:  
see FURTHER INFORMATION sheet PCT/ISA/210
  
3.  Claims Nos.:  
because they are dependent claims and are not drafted in accordance with the second and third sentences of Rule 6.4(a).

## Box II Observations where unity of invention is lacking (Continuation of item 2 of first sheet)

This International Searching Authority found multiple inventions in this international application, as follows:

1.  As all required additional search fees were timely paid by the applicant, this International Search Report covers all searchable claims.
  
2.  As all searchable claims could be searched without effort justifying an additional fee, this Authority did not invite payment of any additional fee.
  
3.  As only some of the required additional search fees were timely paid by the applicant, this International Search Report covers only those claims for which fees were paid, specifically claims Nos.:
  
4.  No required additional search fees were timely paid by the applicant. Consequently, this International Search Report is restricted to the invention first mentioned in the claims; it is covered by claims Nos.:

### Remark on Protest

- The additional search fees were accompanied by the applicant's protest.
- No protest accompanied the payment of additional search fees.

FURTHER INFORMATION CONTINUED FROM PCT/ISA/ 210

Continuation of Box I.2

Claims Nos.: 7-10,12

Present claims 7-10, 12 relate to a product define by reference to the following parameters:

P1: The graded density of the fibers

P2: The loft of the web (in terms of the ratio of volume of the air in a web to the total volume)

The use of these parameters in the present context is considered to lead to a lack of clarity within the meaning of Article 6 PCT. It is impossible to compare the parameters the applicant has chosen to employ with what is set out in the prior art. The lack of clarity is such as to render a meaningful complete search impossible. Consequently, the search has been restricted to claims 1-6, 11 and 13-16.

The applicant's attention is drawn to the fact that claims, or parts of claims, relating to inventions in respect of which no international search report has been established need not be the subject of an international preliminary examination (Rule 66.1(e) PCT). The applicant is advised that the EPO policy when acting as an International Preliminary Examining Authority is normally not to carry out a preliminary examination on matter which has not been searched. This is the case irrespective of whether or not the claims are amended following receipt of the search report or during any Chapter II procedure.

## INTERNATIONAL SEARCH REPORT

Information on patent family members

International Application No

PCT/US 03/11566

| Patent document cited in search report |    | Publication date | Patent family member(s)   | Publication date   |
|--|----|------------------|---|--|
| US 4086381                             | A  | 25-04-1978       | NONE  |  |
| WO 02055782                            | A  | 18-07-2002       | US 2002102897 A1<br>WO 02055782 A2<br>US 2003003834 A1  | 01-08-2002<br>18-07-2002<br>02-01-2003   |
| US 6183684                             | B1 | 06-02-2001       | US 6136245 A<br>US 5688468 A<br>US 5545371 A<br>WO 02063087 A1<br>AU 7152096 A<br>CA 2249712 A1<br>CN 1217756 A ,B<br>EP 0888466 A1<br>JP 2000506942 T<br>WO 9735053 A1   | 24-10-2000<br>18-11-1997<br>13-08-1996<br>15-08-2002<br>10-10-1997<br>25-09-1997<br>26-05-1999<br>07-01-1999<br>06-06-2000<br>25-09-1997   |
| US 4147749                             | A  | 03-04-1979       | NONE  |  |
| US 5296286                             | A  | 22-03-1994       | US 4963298 A<br>AU 658827 B2<br>DE 69128834 D1<br>DE 69128834 T2<br>EP 0540608 A1<br>JP 3022597 B2<br>KR 178360 B1<br>CA 2008421 A1<br>DE 69030338 D1<br>DE 69030338 T2<br>EP 0381206 A2<br>ES 2101679 T3<br>JP 2234909 A<br>JP 2897136 B2<br>AT 162857 T<br>AU 8232191 A<br>CA 2087727 A1<br>JP 5508451 T<br>PL 297657 A1<br>WO 9201829 A1 | 16-10-1990<br>04-05-1995<br>05-03-1998<br>10-09-1998<br>12-05-1993<br>21-03-2000<br>01-02-1999<br>01-08-1990<br>07-05-1997<br>30-10-1997<br>08-08-1990<br>16-07-1997<br>18-09-1990<br>31-05-1999<br>15-02-1998<br>18-02-1992<br>21-01-1992<br>25-11-1993<br>13-07-1992<br>06-02-1992 |
| US 4405297                             | A  | 20-09-1983       | US 4340563 A<br>AU 536472 B2<br>AU 7014081 A<br>BR 8102691 A<br>CA 1160412 A1<br>DE 3117737 A1<br>FR 2481719 A1<br>GB 2077181 A ,B<br>IT 1170940 B<br>JP 1006305 B<br>JP 1540427 C<br>JP 57035053 A<br>KR 8400196 B1<br>MX 152986 A<br>NL 8102208 A ,B,   | 20-07-1982<br>10-05-1984<br>12-11-1981<br>26-01-1982<br>17-01-1984<br>11-02-1982<br>06-11-1981<br>16-12-1981<br>03-06-1987<br>02-02-1989<br>31-01-1990<br>25-02-1982<br>28-02-1984<br>14-07-1986<br>01-12-1981   |
| US 5460500                             | A  | 24-10-1995       | DE 4312419 A1<br>CA 2121383 A1  | 20-10-1994<br>17-10-1994   |

# INTERNATIONAL SEARCH REPORT

Information on patent family members

International Application No

PCT/US 03/11566

| Patent document cited in search report | Publication date | Patent family member(s) | Publication date |
|--|------------------|-------------------------|------------------|
| US 5460500                             | A                | CN 1094463 A            | 02-11-1994       |
|  |                  | IT 1273401 B            | 08-07-1997       |
|  |                  | JP 2556953 B2           | 27-11-1996       |
|  |                  | JP 7109657 A            | 25-04-1995       |
|  |                  |                         |                  |