

May 9, 1933.

E. C. RANEY

1,907,869

THERMIC SWITCH

Filed March 23, 1928

2 Sheets-Sheet 1

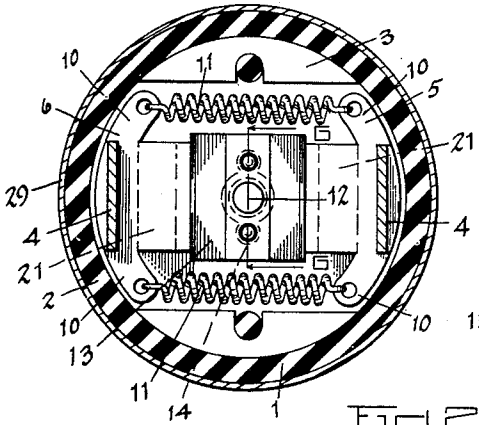

FIG 2

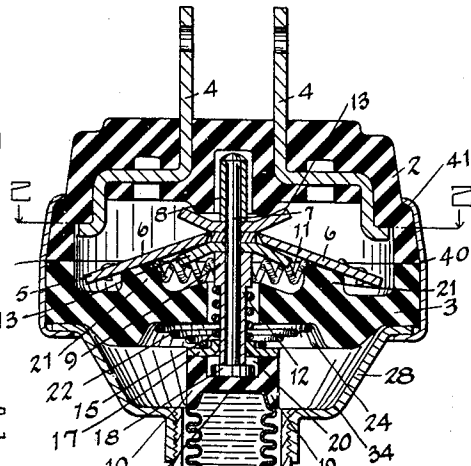

FIG 1

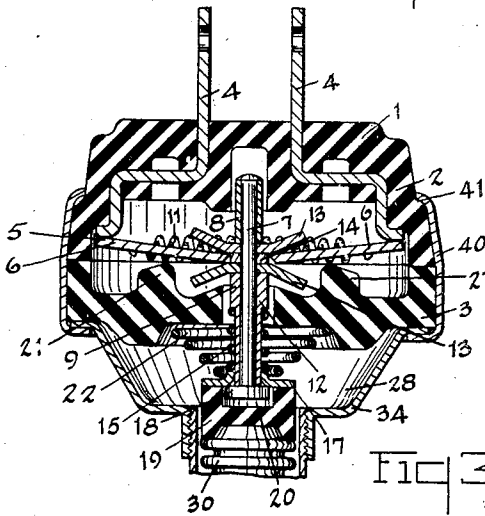

FIG 3

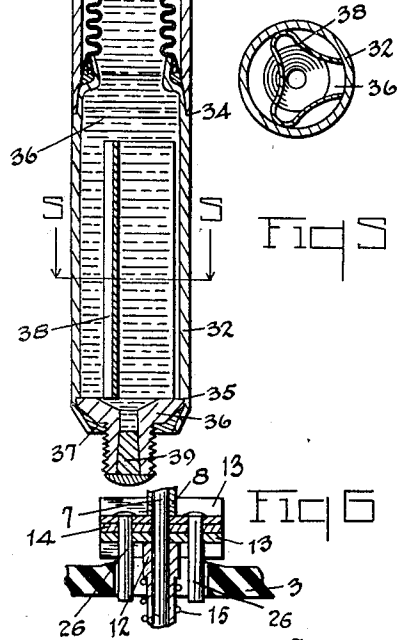

FIG 5

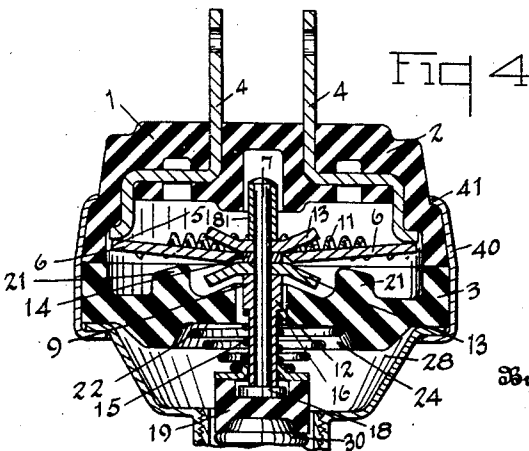

FIG 4

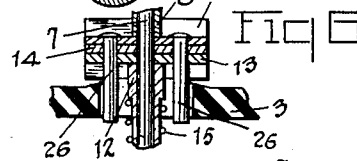

FIG 6

Inventor

Estel C. Raney

Faust F. Crampin

Attorney

May 9, 1933.

E. C. RANEY

1,907,869

THERMIC SWITCH

Filed March 23, 1928

2 Sheets-Sheet 2

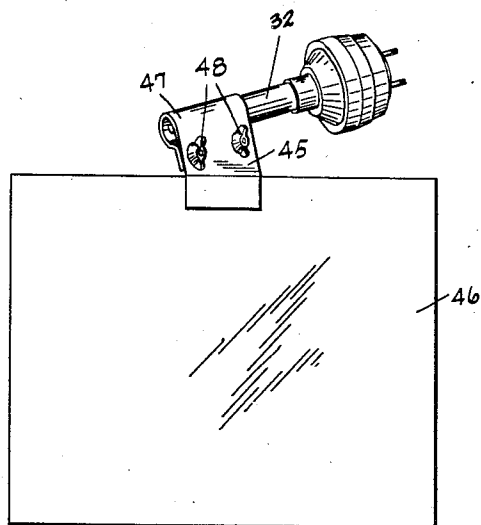

FIG 7

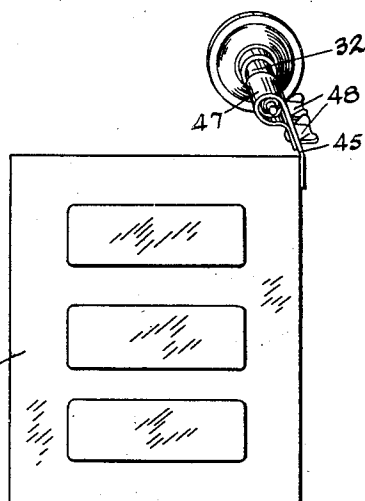

FIG 8

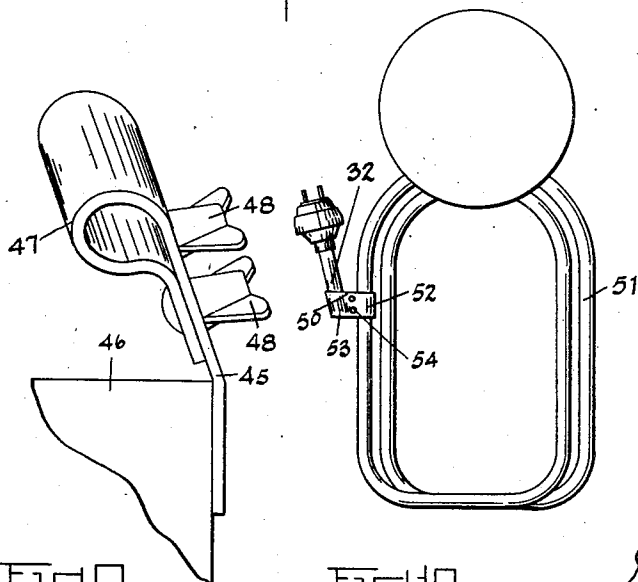

FIG 9

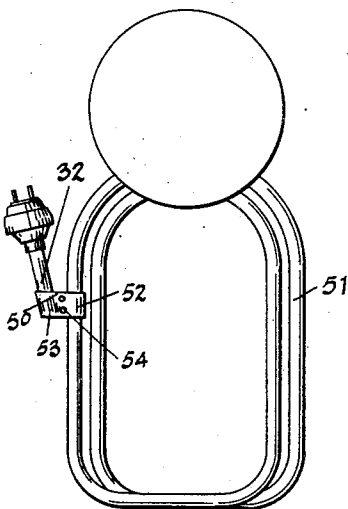

FIG 10

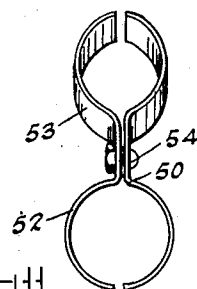

FIG 11

Inventor

Estel C. Raney

By *Faust J. Crampton*

Attorney

UNITED STATES PATENT OFFICE

ESTEL C. BANEY, OF COLUMBUS, OHIO

THERMIC SWITCH

Application filed March 23, 1928. Serial No. 264,040.

My invention has for its object to provide a compact thermally operated electric instrument that will operate with certainty at predetermined temperatures to control a circuit in which the instrument is connected.

The invention particularly provides an exceedingly convenient and efficient instrument that may be readily connected to, or mounted in, or on, a part of an apparatus or construction wherein changes in temperature are used to affect or actuate the instrument, means also being provided for readily connecting the instrument to an external circuit. The switch, or other elements controlling the circuit, is contained in a shell or head formed of insulating material that is sealed against the admission of inflammable and other gases, for the protection of the switch, and the thermic element that operates the switch is contained within a metallic sleeve, or shell, which forms a stem that is securely connected to the insulating shell or head containing the switch. Thus I have provided, by my invention, an integral instrument that may be readily manipulated or mounted and connected in any thermally operated, or thermally controlled, apparatus or device. The invention also provides a thermic switch construction wherein an incompressible thermic fluid is so contained that any change in its volume will positively actuate the switch elements notwithstanding any counteracting spring pressure that may be exerted in the control or manipulation of the switch. Preferably, a material, having a high coefficient of expansion during its change from a solid to a liquid or vice versa, is used. Such a thermic material provides a definite temperature at which a pronounced expansion takes place. The temperature may be made adjustable and predetermined by using different mixtures of materials that have different freezing or congealing or liquefaction points. The invention also provides an exceedingly efficient means for transmitting heat to or from desired points of the thermic element more rapidly than it is transmitted to or from other points in order to produce progressively thermic changes in the physical condition of the

thermic element. Thus, where a freezing solution is used as a part of the thermic element of the switch, it will be caused to freeze progressively from one desired point to another to prevent "plugging" in any portion of the chamber in which the solution may be located.

The invention also provides an expansible container, or bellows, having a small cross sectional area compared to its length, and which is expansible only longitudinally. The bellows is, preferably, used in conjunction with a sleeve or shell, for containing a fluid that is directly in contact with the wall of the shell, the wall of the shell being in immediate contact with or thermally connected to the element or body whose variation in temperature is effective to produce the desired operations of the instrument. The invention also provides details of construction whereby the switch may be efficiently made at a low cost of production.

The invention also has for its object, other features and advantages which will appear from the following description and upon examination of the drawings.

The invention may be contained in structures of different forms and, to illustrate a practical application of the invention, I have selected a thermic switch containing the invention, as an example of such structures, and shall describe it hereinafter. The thermic switch referred to is shown in the accompanying drawings.

Fig. 1 of the drawings illustrates a view of a longitudinal section of the thermic switch, the switch being shown in its open position. Fig. 2 is a view of a section taken on the plane of the line 2—2 indicated in Fig. 1. Fig. 3 is a view illustrating the relative positions of the parts when the switch is closed. Fig. 4 is a view similar to that of Fig. 3 showing the position of the parts when located near the points at which the switch opens. Fig. 5 is a view of a section taken on the plane of the line 5—5 indicated in Fig. 1. Fig. 6 is a view of a section taken on the plane of the line 6—6 as indicated in Fig. 2. Fig. 7 illustrates a side view of a bracket supporting the thermic switch in a desired

relation with respect to a receptacle or part of the apparatus to whose temperature changes the thermic switch is to be made responsive. Fig. 8 is an edge view of the bracket and a perspective view of the thermic switch shown in Fig. 7. Fig. 9 is an enlarged view of the bracket shown in Figs. 7 and 8. Fig. 10 illustrates a modified form of bracket that may be used for supporting the thermic switch. Fig. 11 is an enlarged end view of the bracket shown in Fig. 10.

The instrument embodying my invention has a head of insulating material for containing the electrical controlling parts and a stem of heat conductive material that contains the thermic element. The contacts of the switch are enclosed and sealed within the head or shell 1 of insulating material. The shell 1 is formed of two parts, 2 and 3, and the terminals of the switch are embedded in the part 2 of the shell 1. The terminals extend outwardly from the part 2 of the shell 1 and form blades for plugging into a circuit or making connections through a female plug. The terminals may be bent angularly and used for binding and thus sealing or tightly closing together parts of a plug switch or connector. The inner ends of the terminals form the fixed contacts 4 of the switch. They protrude into the shell and extend laterally so as to form good contacting surfaces. The movable contact 5 of the switch is jointed and comprises a pair of contact plates 6, the ends of which are adapted to make contact with the fixed contacts 4. The outer ends of the plates 6 are elastically drawn towards each other by the springs 11 so that when the inner ends of the plates 6 pass through substantially the plane, in which the outer ends of the plates 6 are located, the outer ends of the plates 6 will be angularly snapped towards each other. The springs 11 operate to produce a pressure in the planes of the plates 6 and lateral pressures at the ends of each plate 6 in opposite directions with reference to the plane of the plate. The lateral components at the outer ends of the plates, either press the plates against the fixed contacts, or move the plates away from the fixed contacts, while the lateral pressures at the inner ends of the plates react or coact with the actuating members of the switch to produce the desired movement of the inner ends of the plates. The lateral pressures will vary according to the inclination of the plates, one relative to the other. The lateral components produced by the springs operate to either produce a relatively high contact pressure or to move the plates away from the fixed contacts.

The movable contact 5, has a member 12 which may be actuated thermically or thermically controlled in its movements.

The member 12 comprises a pin 7 having sleeves 8 and 9 located on opposite sides of the joint of the movable contact 5. A pair of recesses are formed in the member 12 by a pair of plates 13 that are spaced apart by the plate 14, which form the joint of the relatively movable parts of the movable contact 5. The inner ends of the plate 6 of the movable contact are located in the recesses formed by the plates 13. The plates are secured in position by the rivets 26, the pins 7 and the sleeves 8 and 9.

The outer ends of the plates 6 are provided with ears 10 and a pair of tension springs 11 interconnect the ears 10. The inner ends of the plates 6 are thus pressed against the edges of the spacing plate 14, by the tension of the springs 11. If desired, the plates 13 may be bent to allow a slight though limited angular or pivotal movement of the contact plates 6 in the recesses relative to the member 12. Also, the inner ends of the plates 6 may be beveled to position their axes of rotation or pivots substantially in their surfaces located on the sides of the plates on which the fixed contacts are located.

The member 12 which comprises the pin 7 and the sleeves 8 and 9, extends into the walls of the shell 1 and is thus guided in its movements. The rivets 26 extend into a slot formed in the part 3 of the shell and operate to prevent rotation of the movable contact about the axis of the member 12. In order to produce a switch closing movement of the member 12, a pair of projections 21, that protrude from the wall 3 of the insulating shell 1 of the switch, are located close to the movable member 12 and the plates 6 engage the projections 21 at points between their ends, while the switch is open. A spring 22, located in a recess 24 formed on the exterior of the part 3 of the insulating shell 1 and surrounding the member 12, operates to engage the lower end of the member 12 and, when the member 12 is free to move downward, the spring 22 moves the member 12 through the wall 3 of the shell 1 causing the plates 6 to tilt on the projections 21, and when the inner ends of the plates 6 pass through the plane of the outer ends, the springs 11 snap the plates 6 against contacts 4 to close the switch. When the member 12 moves in a direction to open the switch, the inner ends of the contact plates 6 are again moved through the plane passing through the outer ends of the plates 6 and the springs 11 snap the plates 6 away from the fixed contacts 4 and open the circuit, the contact plates 6, moving angularly in the recesses, formed by the plates 13 and 14 of the member 12.

In order to eliminate low contact pressure between the movable and the fixed contacts 5 and 4, that would otherwise occur during

a considerable period of movement of the member 12, as the switch is about to be opened, that is, as the inner ends of the plates 6 approach the plane of the outer ends when the outer ends are in contact with the fixed contacts 4, I have provided a means for forcing the inner ends of the plates 6 through the plane of the outer ends in advance of this low contact pressure period. Thus my invention insures that during the entire closed period of the switch an efficient contact pressure between the movable contact 5 and fixed contacts 4 is maintained.

As is well known in connection with such toggle construction, the lateral pressure component at the joint becomes small and varies but slightly as it approaches zero. The pressure at the joint or pivotal ends of the plates 6, in the direction counter to that in which the member 12 is moved, is the same as the pressure on the contacts 4. By my invention I have provided a means for counterbalancing a predetermined amount of the pressure component in the direction counter to the movement of the member 12 at the pivotal ends of the plates 6 and, consequently, when the pressure at the pivotal ends is reduced slightly below this predetermined pressure, the pivotal ends are snapped through the plane of the fixed contacts and the contact plates are thrown open by the springs 11. Thus, by my invention, an efficient electrical contact pressure is maintained between the contacts of the switch until the switch is opened.

The switch is provided with a resilient member that may be located at any point between the movable contact of the switch and the switch actuating part in order to produce a yielding pressure on the movable contact counter to the action of the springs 11 in advance of a more positive action of the movable switch member. In the form shown, a spring 15 is located intermediate a shoulder 16 formed on the member 12 and a washer 17, that is normally pressed against the actuating member 19. The actuating member 19 is provided with a recess 20 in which the head 18 of the pin 7 is located. The depth of the recess 20 is such as to permit short movements of the head 18 within the recess 20. The actuating member 19 first moves the washer 17 against the pressure of the spring 15 to subject it to a predetermined pressure. The member 19 then engages the head 18 and moves the member 12. During this upward movement, the spring 15 is held compressed while the pressure on the contacts 4, produced by the springs 11, remains substantially constant and is sufficient to produce a good electrical contact pressure between the contacts 6 and 4. When, therefore, the pressure produced by the springs 11 on the inner ends of the plates 6 becomes less than the pressure of

the spring 15, the inner ends of the plates 6 will be snapped through the plane extending through the outer ends of the plates 6 which will dispose the springs 11 below the inner ends of the plates 6 and cause the plates 6 to be snapped to a switch open position. The depth of the recess 20, with reference to the thickness of the head 18 of the pin 7, that is, the play of the head 18 within the recess 20 is, preferably, such as to produce the desired compression in the spring 15 in advance of the opening of the switch and also to permit free movement of the head 18 toward the washer 17 to enable the quick movement of the inner ends of the plates 6 by the spring 15 from one side of the plane of the fixed contacts 4 to the other side which operates to reverse lateral components of the pressure of the springs 11 to cause the switch to open with a quick snap movement. The springs 11 thus operate to tilt the contact plates 6 over the projections 21 to throw the outer ends down and the inner ends up, thereby producing a wide opening between the contacts 4 and 6 of the switch. When the member 12 moves to close the switch, it will tilt the plates 6 on the projections 21 and raise the outer ends, by a comparative short movement of the member 12, which rapidly raises the springs above the pivotal ends of the plates 6 and causes the switch to close with a quick snap movement. Thus but short inward and outward movements of the movable member 12 are required to close and widely open the switch and, consequently, makes this form of construction particularly valuable in connection with switches that operate by the slow and slight changes in dimensions that are produced by the thermic expansion of materials.

The switch may be operated by any form of thermic structure or element and at any temperature. The form of construction shown in the drawings is used for controlling the operations of a refrigerating apparatus. A container comprising a sheet metal bellows is filled with a solution or a mixture of liquids that will solidify at a desired temperature, such as, for example, water and alcohol or mixtures of waxy materials and, by reason of the definite change in volume produced at solidification or liquefaction, cause or enable the distension or contraction of the bellows and movement of the movable member to open the switch. If desired, the bellows may be connected to a shell to locate the thermic materials in more immediate heat conductive relation with the exterior of the container and provide space for solidification of the material without interference with responsiveness or effectiveness of the bellows.

Hence, as shown in the drawings, the bellows 30 has an upper end portion 31 that is

located in a recess formed on the lower side of the block or actuating member 19. The lower end of the bellows 30 is connected to a cartridge or shell 32. The bellows 30 is
 5 located in a sleeve 33 that is suitably connected to the head or shell 1. The bellows 30 and the shell 32 are filled with a liquid whose volumetric changes may be utilized for operating the switch, such changes in
 10 volume being effective to produce changes in the linear dimension of the container of the material, namely, the combined volume of the bellows 30 and the shell or cartridge 32.

15 In the form of construction shown in the drawings, the upper end of the shell 32 is cut back to form the shoulder 34 and the end portion is contracted by spinning to form substantially the shape shown in Fig.
 20 1. The lower edge portion of the bellows 30 is fitted over the upper edge portion of the shell 32 and is soldered thereto. Also, in the formation of the shell 32, the interior of the lower end portion is cut back to form the shoulder 35, and a nipple 36 is
 25 inserted in the lower end of the shell 32 and the lower edge portion of the shell is bent over the portion of the nipple 36 located within the end of the shell 32. Solder
 30 37 may be inserted for sealing the nipple 36 around the edge of the portion of the nipple 36 that is located within the shell 32.

In advance of the insertion of the nipple within the end of the shell, a heat conductor
 35 38 is located within the shell. The heat conductor may be formed of any suitable material that has a high coefficient of heat conductivity, such as one of the metals, preferably, copper, and is so formed as to extend from the central or axial portions of
 40 the shell 32 to the wall of the shell 32. Thus the conductor 38 may be so shaped, or bent, as to have fins, or parts, that are in contact with the wall of the shell 32 and parts
 45 that are located centrally within the shell 32 in order that the heat may be transmitted from the central portion of the material that may be located in the shell 32. Hence, in case there is a change in the physical condition of the material, brought by a change
 50 in temperature conditions, such changes in conditions will occur quite as rapidly in the central portion of the material within the shell 32, as at the wall of the shell 32.
 55 There will thus be produced substantially a uniform rate of change per unit of volume throughout the mass of material within the shell 32 and, consequently, a substantially uniform rate of change of its physical condition, where such change occurs, throughout the material located within the shell 32.
 60 Also, the conductor may be shaped to locate a greater portion of the metal from which it is formed in the lower end of the shell to
 65 direct the heat to and from the material in

the lower end of the shell at a greater rate.

The particular conductor or heat distributor, shown in the drawings, consists of a sheet metal piece bent to form a prismatic configuration having a triangular cross section but whose sides are curved and whose
 70 edges are rounded. The sheet material being elastic and the edges of the sheet metal along one of the corners of the substantially three sides prism being left free, consequently, the conductor will be resiliently held in
 75 its position by its distension or by the separation of the edges of the sheet metal piece. Thus the rounded corners and the edges of the conductor will be maintained in contact with the wall of the shell 32 and will distribute or conduct the heat to and from the
 80 wall of the shell 32 and substantially uniformly throughout the body of the liquid contained within the shell 32.

Where the thermic switch is used for controlling the operation of the refrigerating apparatus, the shell 32 and the bellows 30 is filled with a solution or a mixture of liquids so proportioned that it will freeze or congeal at predetermined temperatures, preferably, at temperatures at which the switch is to be operated in order that advantage of the expansion, that occurs upon freezing of the liquid may be taken. By reason of the means that is provided for more readily conducting heat to and from that portion of the liquid located in the shell 32 than to the bellows 30, the bellows 30 being shielded and partially heat insulated by the air located intermediate the bellows 30 and the sleeve
 90 33, the portion of the liquid in the shell 32 is more effective in its control of the switch, that is, the liquid in the shell 32 freezes or congeals well in advance of any congealing of the liquid in the bellows 30. Freezing of the liquid in the bellows is avoided as much as possible in order to prevent distortion of the bellows. Thus the liquid in the bellows operates to transmit the pressure created by the freezing of the liquid in the shell 32. It constitutes a mobile material which is moved by the expansion of that portion of the liquid that solidifies. Consequently, any liquid that will perform the function of transmitting pressures may be used in conjunction with the mixture, such as oil, which will maintain itself separated from the congealable liquid. The liquid is inserted through the nipple 36 and when the bellows
 100 30 and the shell 32 have been filled, the nipple is closed by means of the metal plug 39. The shell 32 is then soldered or sweated into the end of the sleeve 33 and the sleeve 33 may be connected to a flaring collar 34. In order to properly locate the upper end of the bellows 30, with respect to fixed portions of the shell, to cause the opening and closing of the switch at predetermined points of location of the upper end of the bellows 30.
 105
 110
 115
 120
 125
 130

The sleeve 33 may be threaded into the collar 34 for purposes of adjustment as well as for purposes of connecting the thermic element to the switch and when thus adjustably located, the sleeve 33 may be soldered to the flaring collar 34.

The collar 34 may be connected to the head or shell 1 by means of the collar 40 whose edges extend inwardly and so as to engage the shoulder 41 formed on the part 2 of the shell and beneath the lower edge of the part 3 of the shell and beneath an edge portion of the flaring collar 34. Thus the collar 40 may be forced onto the head or shell 1 and the lower edge may be spun down so as to tightly clamp and seal the interior of the shell 1 and the sleeve 33. This prevents the entrance of any inflammable gas into the shell 1 or the entrance of any corrosive gas within the sleeve 33 that might attack the bellows 30.

The liquid within the shell 32 is necessarily in intimate contact with its wall and, consequently, the heat transmitted to and from the material, within the sleeve, has a large area and an exceedingly short distance for such transmission. Also, the heat conductor 38 quickly distributes any difference in temperature in the portions of material located within the shell and, since the bellows 30 is separated from the wall of the sleeve 33, the resistance to heat transmission is increased from the bellows 30 to the exterior of the sleeve 33, the thermic material at the lower end of the shell 32 will be affected first and the material will be progressively affected from the lower end of the sleeve 32 to the upper end of the bellows. Thus, where the solution is a freezable solution, the liquid will freeze substantially progressively, beginning at the lower part of the shell 32 and continuing upward. This prevents freezing above an unfrozen quantity of the liquid which would otherwise tear open or burst the container of the liquid and damage the bellows. The heat conductor 38 and its location thus operates to protect the bellows 30. Owing to the volume of the liquid and the short movement required for the operation of the switch and the provision of means for causing the progressive freezing of the liquid, the switch will be operated in advance of the freezing of the liquid within the bellows 30 if a freezing liquid is also located in the bellows. Thus, by the construction described, the interior of the bellows 30 and the shell 32 may be filled with a single solution or liquid and the switch may be operated by the congealing of that portion of the liquid located within the shell 32 and the portion of the liquid within the bellows 30 may be used for the transmission of the movement caused by the expansion of the liquid within the shell 32 when it freezes. Also, the bellows 30 and

its connected shell 32, having a relatively large total length and small diameter, provide an exceedingly large conductive area proportional to its volume and increases its linear dimension per degree of change in temperature which, in turn, increases the sensitiveness of the switch.

Also, in order to aid in the progressive change of the physical condition of the thermic material used in the instrument to transform temperature changes into mechanical movements, I have provided a means for supporting the thermic switch in a definite relation to the part of the system or apparatus or construction whose temperature changes produce the variations in the instrument. Also, the supporting means may be so constructed as to present varying resistance to heat transmission to different points in the thermic material in the instrument. Where the instrument is used in connection with a refrigerating apparatus, it may be mounted on the brine container, such as the brine vat or refrigerant container 46, indicated in Figs. 7 and 8, or it may be mounted on the refrigerating coils 51, shown in Fig. 10, by means of a bracket. The bracket will not only be a means of conduction of heat to and from the thermic device, but will also so support the thermic device as to locate the lower end of the shell 32 nearer to the part of the refrigerating apparatus, whose temperature is to determine the operation of the switch, than the upper end of the shell 32. Thus there will be afforded a lower resistance to heat transmission at the lower end of the thermic device than at any other point which will cause the change in the physical condition to occur, first at the lower end of the stem of the thermic device and then, progressively, upward.

As shown in Figs. 7, 8, and 9, the bracket 45 is provided with a spring clamp that makes contact with substantially the entire area of the exterior surface of the shell 32. In the form of construction shown in Fig. 7, the bracket 45 is formed of relatively thick sheet metal in order to afford a considerable cross sectional area for the transmission of heat. The bracket 45 is bent to form the loop 47 along one side edge portion which may be provided with winged nuts 48, located on suitable bolts, for closing the end of the loop 47 and reducing the cross sectional area within the looped portion of the bracket 45. This affords a means for frictionally engaging the shell 32 and maintaining the interior surface of the looped portion of the bracket 45 in contact with the shell 32.

In the form of construction shown in Figs. 10 and 11, the bracket 50 is for the purpose of connecting the thermic element to the refrigerating coils 51 of the apparatus. In

order to connect the thermic element to the coils 51, the bracket 50 may be so formed that it may be placed about one of the turns of the coils 51 which will afford a large contact area for the transmission of the heat between the coils 51 and the instrument. Consequently, the bracket 50, shown in Figs. 10 and 11, may be formed of thin metal. The bracket 50 is also so formed that the thermic device will be supported relative to the refrigerating coil 51 such that its lower end will be located in closer proximity to the coil 51 than the upper end of the thermic device. The bracket 50 is, preferably, formed of a pair of sheet metal parts which are bent to conform to the exterior cylindrical surfaces of the coil 51, as at 52, and the shell 32, as at 53. The parts 55 and the bracket 50 may be secured together so as to clamp the coil 51 and the sleeve 32 by the bolts and nuts 54 that extend through central portions of the parts of the bracket 50. Inasmuch as the axes of the cylindrically formed portions 52 and 53 are inclined, one relative to the other, the upper end of the shell 32 may be located more remote from the coil 51 than the lower end of the shell 32 and, consequently, there will be a greater heat flow at the lower end of the shell 32 than at the upper end of the shell 32.

I claim:

1. In a thermic switch, a two part shell of insulating material, electric terminals embedded in one wall and having contacts located in the enclosure of the shell, a movable member extending through another wall, a thermic expansible container, a sleeve surrounding the said expansible container, a flange connected to the sleeve, and a collar for clamping the parts of the shell and the flange together and sealing the interior of the shell and the sleeve.

2. In a thermic switch, a two part insulating shell, fixed contacts mounted in the shell, a movable contact for electrically connecting the fixed contacts, a movable member for operating the movable contact, a sleeve containing a thermic expansible element for actuating the movable contact, and a means for clamping together the parts of the shell and connecting the sleeve to the shell and sealing the interior of the shell and the sleeve.

3. In a switch, a fixed contact, a movable contact, means for pressing the movable contact against the fixed contact, an actuating member for moving said movable contact, a resilient means interposed between the actuating member and the movable contact to cause separation of said contacts whenever the contact pressure becomes less than the pressure of the interposed resilient means.

4. In a switch, a fixed contact, a movable contact, an actuating member and an elastic

means for operating the movable contact, a resilient member located intermediate the movable contact and the actuating member for controlling the operations of the movable contact by the pressure exerted on the resilient member.

5. In a switch, a fixed contact, a jointed movable contact, means for pressing the movable contact endwise and against the fixed contact and producing a lateral component at the joint of the movable contact, and a yielding means operating on the joint for maintaining the pressure on the fixed contact above a predetermined effective contact pressure as the movable contact is moved.

6. In a switch, a pair of fixed contacts, a jointed movable contact, an actuating member for moving the movable contacts relative to the fixed contacts, means for pressing the parts of the movable contact endwise and for producing lateral pressure components at the ends of the parts of the jointed movable contact against the fixed contacts and at the joint, a yielding means interconnecting the actuating member with the parts of the contact at the joint for reversing the direction of the pressure components when their values are reduced to a predetermined effective contact pressure as the movable contact is moved, and means for connecting the actuating means and the joint of the movable contact for producing short free movements of the movable contact relative to the actuating member when the direction of the pressure components is reversed.

7. In a device adapted to be actuated by the change in temperature in a thermic system, a heat conductive container, a thermic material located within the container for actuating the device, and a heat conductive element located intermediate the container and the said part of the system, the conductivity of the said element between the said container and the said part varying in different portions.

8. In a device adapted to be actuated by the change in temperature in a thermic system, a heat conductive container, a thermic material located within the container, a heat conducting element located intermediate the container and the said part of the said system, the conductivity of the said element between the said container and the said part varying in different portions, and a heat conductor located within the said container and the said thermic material for distributing the heat in the said thermic material.

9. In a device adapted to be actuated by the change in temperature in a thermic system, a metallic stem, a thermic material located within the stem, a heat conducting element located intermediate the stem and the said part of the said system, the portion of the said element located interme-

diate the said part of the said system and one end of the stem having a higher conductivity than the other portions of the said element.

5 10. In a device adapted to be actuated by the change in temperature in a thermic system, means for supporting the parts of the device, a thermic fluid material operatively connected to the device, and means for conducting heat at variable rates to different portions of the thermic fluid.

11. In a device adapted to be actuated by the change in temperature in a thermic system, a means for supporting parts of the device, a thermic element operatively connected to the device, a bracket connected to the said part for supporting the thermic element so as to locate a part of the thermic element nearer to the said part than other parts of the thermic element.

12. In a device adapted to be actuated by the change in temperature in a thermic system, a head of insulating material for enclosing the parts of the device, a stem for supporting the head, a thermic material located within the stem and operatively connected to the device, a heat conductive member located intermediate the stem and the said part to produce less resistance to heat conduction between the stem and the said part.

13. In a device adapted to be actuated by the change in temperature in a thermic system, a stem, a thermic material located within the stem, a heat conducting element located intermediate the stem and the said part of the said system, the conductivity of the said element between the said stem and the said part varying in different portions, the portion of the said element located intermediate the said part of the said system and one end of the stem having a higher conductivity than the other portions of the said element, and a heat conductor located within the said stem and the said thermic material.

14. In a switch, a shell of insulating material for enclosing the switch, a pair of fixed contacts, a jointed movable contact for making contact with the fixed contacts, a spring connected to the parts of the movable contact for producing an endwise thrust in the contacts, and lateral pressure components at the ends of the parts of the contacts, an actuating member for moving the joint of the movable contact to operate the movable contact, the wall of the shell having projections extending in the direction that the joint is moved by the actuating member, and for engaging the parts of the movable contact at points intermediate the joint and the points of connection of the spring for swinging the parts of the movable contact to widely open the switch and to quickly close the contact upon relatively

short movements of the joint of the movable contact.

15. In a switch, a head for enclosing parts of the switch, a shell, a bellows connected to the shell, a thermic material located within the shell and bellows, a sleeve surrounding the bellows and connected at one end to the shell and at the other end to the head, the bellows operatively connected to the movable member of the switch.

16. In a switch, a head for enclosing parts of the switch, a shell, a bellows connected to the shell, a thermic material located within the shell and bellows, a sleeve surrounding the bellows and connected at one end to the shell and at the other end to the head, the bellows operatively connected to the movable member of the switch, and a heat conductor located in the thermic material in the lower end of the shell.

17. In a switch, a fixed contact, a movable contact, means for pressing the movable contact against the fixed contact, an actuating member for moving the said movable contact, and means operated by the actuating member for causing separation of the said contacts whenever the contact pressure reaches a pre-determined value.

18. In a switch, a pair of contacts for closing the circuit of the switch, one of said contacts operated by a jointed member, a spring interconnecting the outer ends of the member for opening and closing the contacts when the joint of the jointed member passes through the plane of the spring, a support for the switch, the support having projections extending in the direction of movement of the joint of the member in the opening and closing the switch for engaging the parts of the jointed member at points intermediate the joint and the points of connection of the spring upon opening the switch.

19. In a switch, a closed shell of insulating material, a pair of metallic strips having parts located within the shell and forming the fixed contacts of the switch, and parts protruding from the wall of the shell and forming circuit connecting blades and parts extending through the wall of the shell and embedded in the wall of the shell for securing the fixed contacts and the circuit connecting blades in position, and a movable contact for electrically connecting the fixed contacts.

20. In a switch, a fixed contact, a movable contact, an actuating member and an elastic means for operating the movable contact, a resilient member for resiliently opposing the pressure produced by the elastic means and located intermediate the contact and the actuating member for operating the movable contact when the pressure of the resilient member slightly exceeds the pressure of the elastic means against the resilient member.

21. In a switch, a fixed contact, a movable contact, an actuating member, a resilient means interconnecting the movable contact and the actuating member, an elastic member counteracting the resilient means and operating to resiliently maintain the movable contact in either its opened or closed positions, the resilient member and the elastic member operating to oppose each other, the resilient member coacting with the actuating member to close the said contacts when the pressure of the resilient member diminishes to a predetermined point.
22. In a switch, a fixed contact, a movable contact, elastic means for pressing the movable contact against the fixed contact, an actuating member for moving the said movable contact, a resilient means interposed between the actuating member and the movable contact to cause separation of said contacts whenever the contact pressure becomes less than the pressure of the interposed resilient means.
23. In a switch, an actuating member, a fixed contact, a movable contact, an elastic member for pressing the movable contact against the fixed contact, a resilient member located intermediate the movable contact and the actuating member for subjecting the elastic member to a tension for controlling the operations of the movable contact according to the contact pressure of the movable contact against the fixed contact, means for connecting the movable contact to the actuating member to permit short free movements of the movable contact relative to the actuating member by the resilient member and the elastic member.
24. In a switch, a fixed contact, a jointed movable contact, means for pressing the movable contact endwise and against the fixed contact and producing a lateral component at the joint of the movable contact, and a yielding means operating on the joint against the pressure of the first named means for maintaining the pressure on the fixed contact above a predetermined effective contact pressure as the joint of the movable contact is moved relative to the fixed contact to maintain a substantially constant contact pressure notwithstanding the changes in pressure of the first named means, and until the contact is open.
25. In a switch, a pair of fixed contacts, a jointed movable contact, means for pressing the movable contact endwise towards the joint and against the fixed contacts, an elastic means for counteracting lateral pressures at the joint of the movable contact, and maintaining the pressure of the movable contact against the fixed contact above a predetermined effective contact pressure, and means for reversing the direction of the lateral pressure components at the ends of the movable contact when their values are reduced to a pressure slightly less than that of the elastic means.
26. In a device adapted to be actuated by the change in temperature in a thermic system, a metallic stem, a bellows located within the stem, one end of the bellows being closed and the edge of the other end connected to the interior of the stem, a thermic material located within the bellows and the end portion of the stem located between an end of the stem and the point of connection of the edge of the bellows to the stem, a metal bracket secured to the said end portion of the stem and the said part of the system.
27. In a device adapted to be actuated by the change in temperature in a thermic system, a metallic stem, a bellows located within the stem, one end of the bellows being closed and the edge of the other end connected to the interior of the stem, a thermic material located within the bellows and the end portion of the stem located between an end of the stem and the point of connection of the edge of the bellows to the stem, a metal bracket secured to the said end portion of the stem and the said part of the system, and a metal heat conductor located within the said end portion of the stem for distributing the heat within the thermic material and to and from the wall of the said end portion of the stem.
28. In a device adapted to be actuated by the change in temperature in a thermic system, a thermic fluid material operatively connected to the device, a container for the thermic fluid material and for supporting the thermic switch, and a bracket for connecting the container to the part of the system for conducting heat to and from one end of the container, the other end of the container separated from the said part by a relatively non-heat-conductive medium, the said bracket operating to conduct more heat to and from one portion of the thermic material than is conducted to and from the other portion of the thermic material to produce progressive expansion and contraction of the material in the said portions.
29. In combination with a thermic switch, a thermic element for operating the switch and comprising a closed shell having a rigid wall and a flexible wall, a liquid located in the shell, a metal member extending across the interior of the shell for increasing heat conductivity from the wall of the shell to the interior of the shell.
30. A thermic expansible element comprising a closed shell having a rigid wall and a flexible wall, a freezable liquid located in the shell, a metal member extending across the interior of the shell for increasing the conductivity of heat between the wall of the shell and the interior of the shell to produce thermic response of the

freezable liquid located in the more central parts of the shell.

31. A thermic expansible element comprising a closed shell having a rigid wall and a flexible wall, a freezable liquid located in the shell, a metal member extending across the interior of the shell for increasing the conductivity of heat between the wall of the shell and the interior of the shell to produce prompt thermic response of the freezable liquid located in the more central parts of the shell and means actuated by movement of the flexible member in response to the change in volume of the thermic element.

32. A thermic element comprising an interconnected bellows and a shell forming a closed chamber, the shell filled with a thermic freezable liquid and the bellows filled with a liquid material, a metal member extending across the shell for increasing the heat conductivity through the shell.

33. A thermic element comprising an interconnected bellows and a shell forming a closed chamber, the shell filled with a thermic freezable liquid and the bellows filled with a liquid material, a metal member extending across the shell for increasing the heat conductivity through the shell, and means actuated by the movement of the flexible member in response to the change in volume of the thermic element.

34. A thermic element comprising a closed shell having a lateral rigid wall and a flexible end wall, the shell containing a freezable liquid, and a metal member located within the shell and in contact with the lateral rigid wall of the shell for increasing the heat conductivity between the lateral wall of the shell and the central portions of the shell.

35. A thermic element comprising an interconnected bellows and a shell forming a closed chamber, the shell filled with a thermic freezable liquid and the bellows filled with a liquid material, a metal member extending across the shell for increasing the heat conductivity through the shell, and means actuated by the expansion of the thermic element.

36. A thermic element comprising a closed shell having a lateral rigid wall and a flexible end wall, the shell containing a freezable liquid, and a metal member located within the shell and in contact with the lateral rigid wall of the shell for increasing the heat conductivity between the lateral wall of the shell and the central portions of the shell, and means actuated by the expansion of the thermic element.

In witness whereof I have hereunto signed my name to this specification.

ESTEL C. RANEY.