

L. EHRLICH & J. A. KEYES.
REGISTER FOR FARES.

No. 453,884.

Patented June 9, 1891.

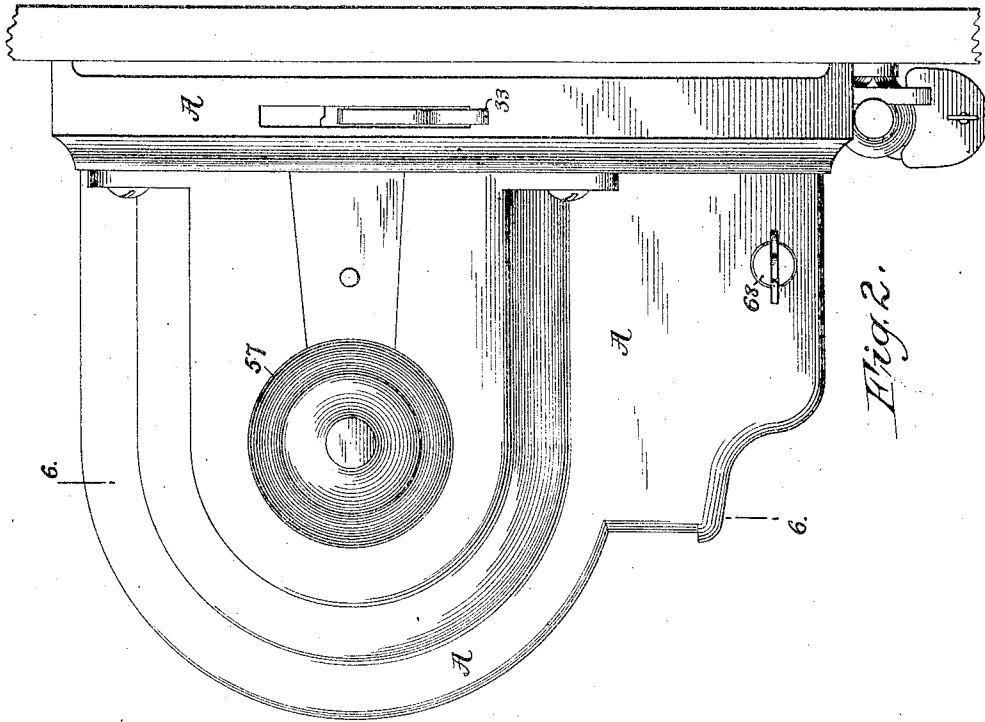

Fig. 2.

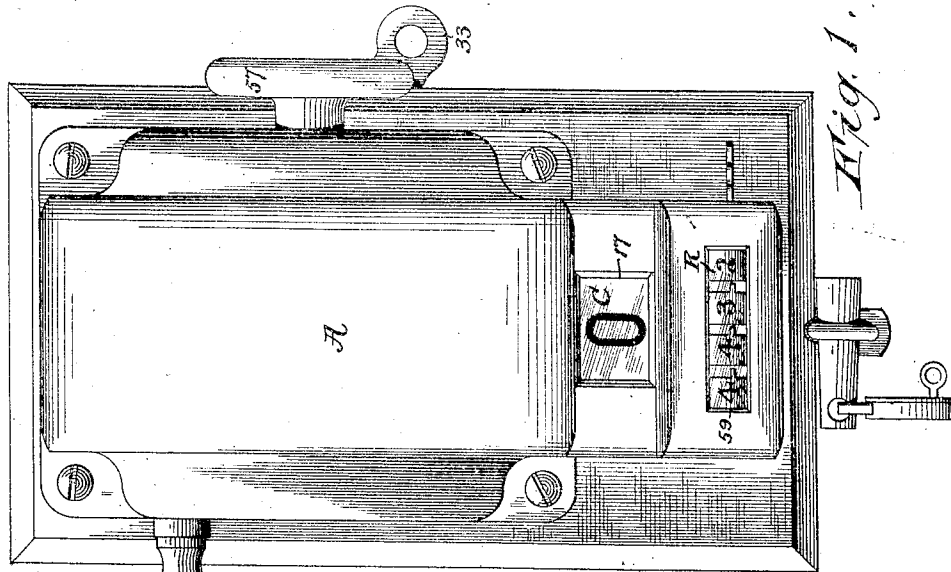

Fig. 1.

Witnesses
 G. Benjamin
 Nettie Marber

Inventors
 Leo Ehrlich & James A. Keyes
 by Geo. H. Graham atty.

L. EHRLICH & J. A. KEYES.
REGISTER FOR FARES.

No. 453,884.

Patented June 9, 1891.

Fig. 3.

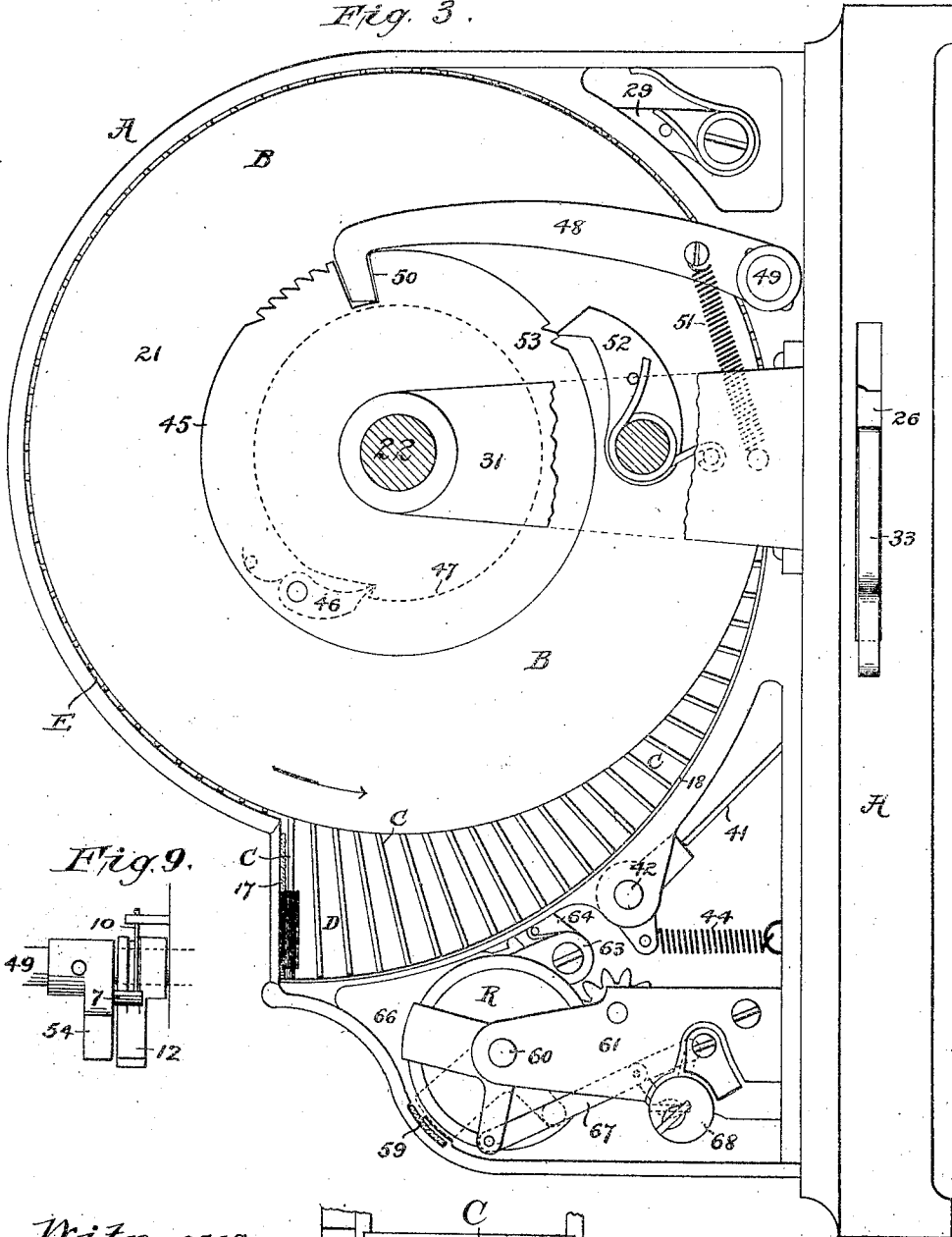
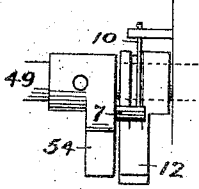

Fig. 9.



Witnesses
 Chas. Benjamin
 Nettie Marler

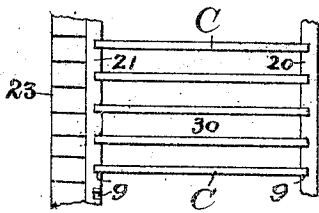

Fig. 7.

Inventors
 Leo Ehrlich
 & James A. Keyes
 by G. H. Palmer
 atty.

(No Model.)

5 Sheets—Sheet 4.

L. EHRLICH & J. A. KEYES.
REGISTER FOR FARES.

No. 453,884.

Patented June 9, 1891.

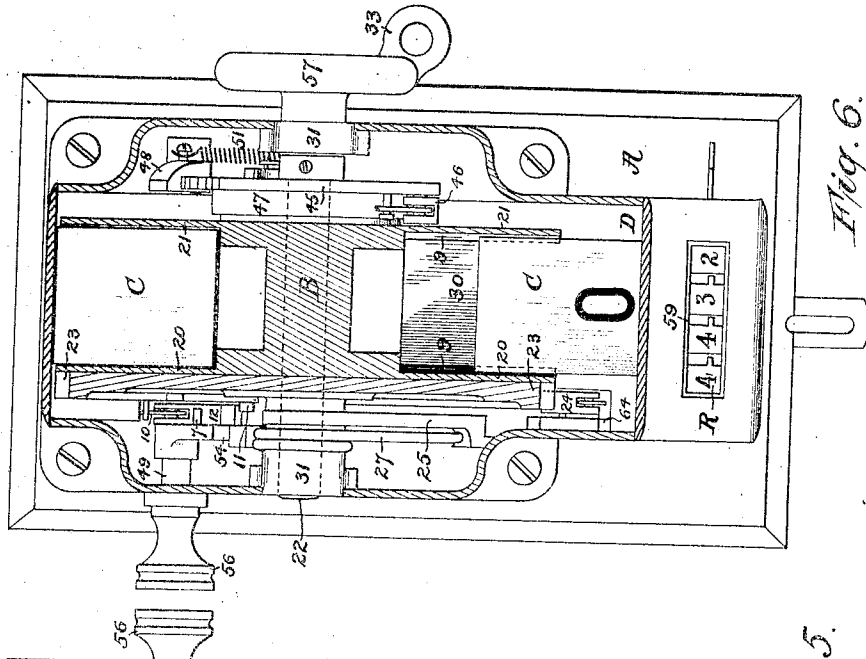

Fig. 6.

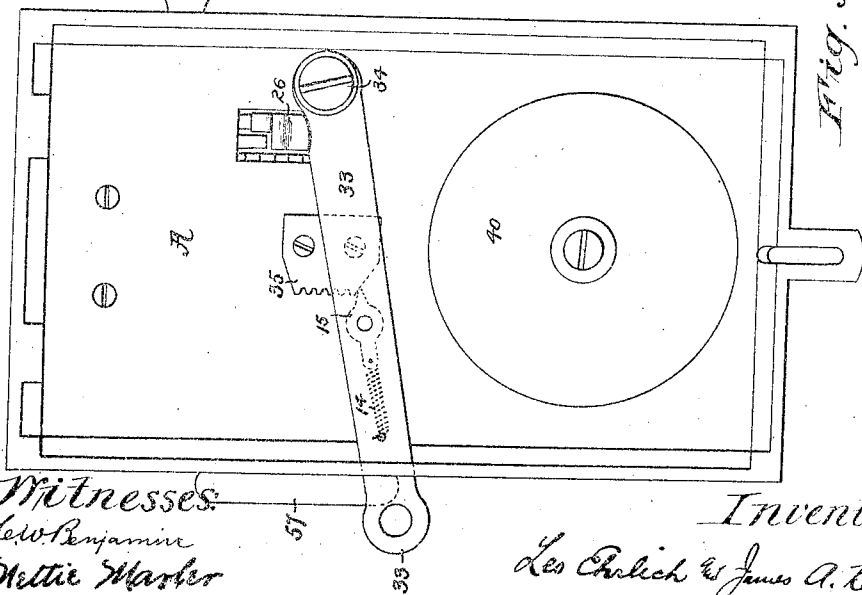

Fig. 5.

Witnesses:
Geo. Benjamin
Nettie Warner

Inventor:
Les Ehrlich & James A. Keyes.
by Geo. H. Mahan
Atty.

L. EHRLICH & J. A. KEYES.
REGISTER FOR FARES.

No. 453,884.

Patented June 9, 1891.

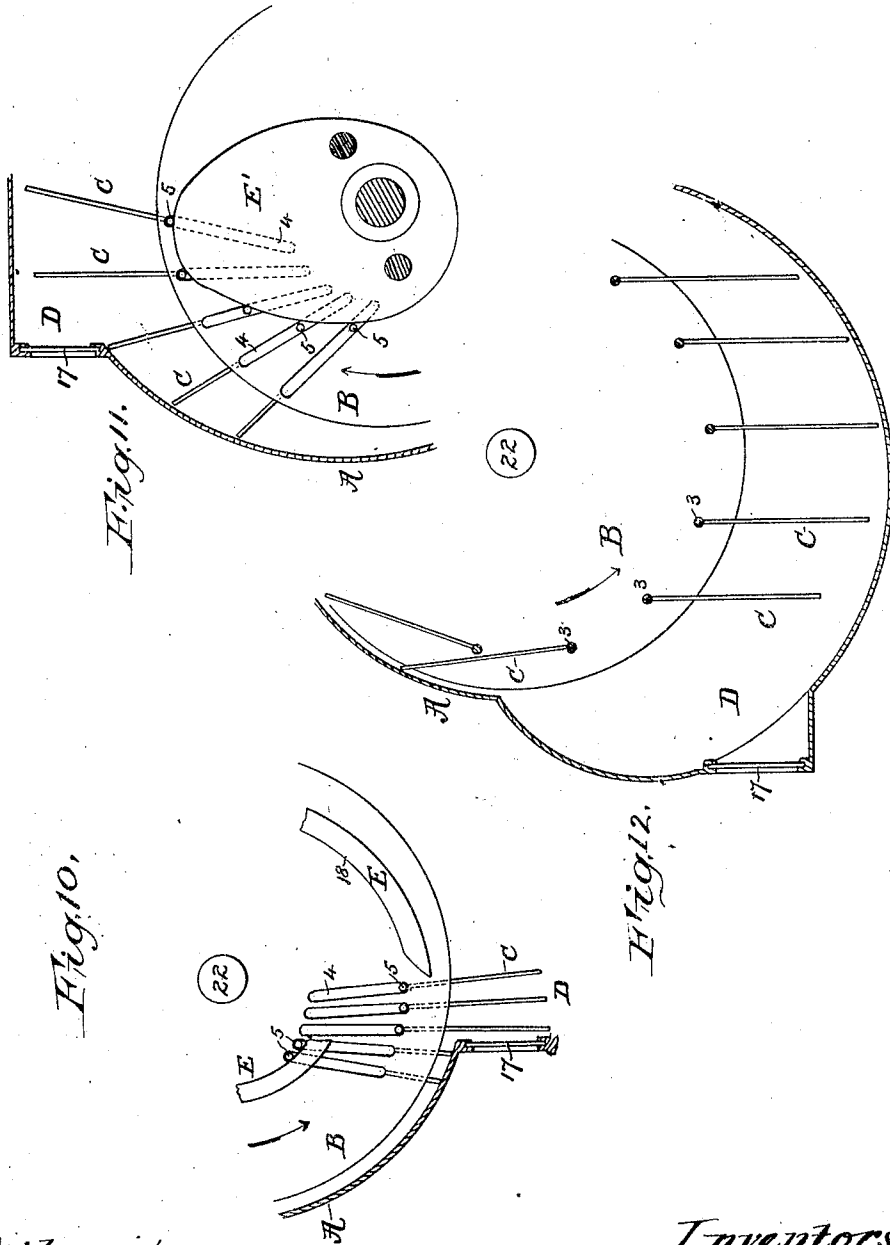

Witnesses:
C. M. Benjamin
Nettie Warler

Inventors
Leo Ehrlich & James A. Keyes
by Geo. H. Graham
attys.

UNITED STATES PATENT OFFICE.

LEO EHRLICH, OF ST. LOUIS, MISSOURI, AND JAMES A. KEYES, OF NEW YORK, N. Y., ASSIGNORS, BY DIRECT AND MESNE ASSIGNMENTS, TO THE ST. LOUIS REGISTER COMPANY.

REGISTER FOR FARES.

SPECIFICATION forming part of Letters Patent No. 453,884, dated June 9, 1891.

Application filed November 27, 1889. Serial No. 331,741. (No model.)

To all whom it may concern:

Be it known that we, LEO EHRLICH, residing at St. Louis, State of Missouri, and JAMES A. KEYES, of the city, county, and State of New York, both citizens of the United States, have invented certain new and useful Improvements in Registers, fully set forth in the following description and represented in the accompanying drawings.

This invention relates, generally, to registers, and more particularly to that class commonly known as "street-car registers"—that is to say, to that class of registers that are particularly adapted to keeping tally, indicating the tally, and registering the amount or quantity tallied.

The present invention provides a structure differing materially from street-car registers now in common use, in that the usual fixed dial and the movable index-hand moved over the face of the dial are dispensed with. The improved register also differs from those now in common use in its mode of operation, in its simplicity of construction, and in the large reduction of the number of parts necessary to make a complete organization that will accurately tally and register the number of times it is operated, at the same time preventing any adroit manipulation by which the tally may be changed and the registered total falsified.

Having these characteristics, the improved register embraces, essentially, a holder or carrier adapted to contain or support a plurality of indicators that may be exposed one by one in succession as the register is operated to indicate, for instance, the number of fares collected, a means by which the carrier and its indicators may be returned to zero or to their normal starting point, a novel means for sounding an audible alarm, and an adding or totalizing device upon which the total number of operations of the register is transferred and preserved, all of which will be hereinafter fully set forth, aided by the accompanying drawings.

In said drawings, Figure 1 is a front elevation of a register embodying the present improvements. Fig. 2 is a side elevation thereof. Fig. 3 is an enlarged side elevation of the

same with a portion of the inclosing case removed to expose the interior. Fig. 4 is a similar view looking from the opposite side of the register. Fig. 5 is a rear elevation. Fig. 6 is a sectional elevation taken on the line 6 6 of Fig. 2. Fig. 7 is a view of a portion of the carrier looking at its periphery. Fig. 8 is an elevation of the bell-hammer and its arm. Fig. 9 is an elevation of the locking and stop arms and the rock-shaft. Figs. 10, 11, and 12 are modified forms hereinafter referred to.

Referring to said drawings, it will be understood that the improved structure is supported by and mounted within an inclosing case A, adapted to be secured in any convenient position or place—as, for instance, the side or end of a car or other vehicle.

The register consists, essentially, of a holder or carrier B, adapted to receive or support a number of indicators C, that are movable with respect to the holder or carrier, so that they may be moved to expose their indications. It is to be understood that the invention is not limited to any particular form of holder or carrier, or any particular form of indicators, or any particular mode of mounting the indicators with respect to the holder so long as the indicators are movable with respect to the carrier and adapted to be exposed one by one in the operation of the register. In the preferred construction of the holder or carrier B it consists of a pair of disks 20 21, that are secured together in such manner as to provide between them a chamber 30, capacitated to receive and support a number of indicators. The carrier is a rotatable one, mounted to turn upon a shaft 22, that finds bearings in a pair of brackets 31, extending from and forming a part of the inclosing case.

The indicators C consist of plates or tablets, preferably of rectangular form and formed of any suitable material, such as celluloid, vulcanized rubber, and the like. They may vary in number, according to the desired capacity of the register, and each indicator will bear an indication of its number or value delineated upon its face. In the present instance there are one hundred indicators, bearing numerals on their faces extending from 0, 1, 2, 100

and so on, to 99, inclusive, and are so arranged that as the register is operated the indicators will be exposed in numerical order.

As before stated, many modes of mounting the indicators to the carrier may be employed. The preferred mode, and, it is believed, the most effective, is that shown, wherein the indicators are each arranged to slide in grooves 9, formed in the opposite inner faces of the carrier-disks, Figs. 6 and 7, and by which they are guided in their movements with respect to the carrier. The indicator-tablets move freely in the grooves and are of a length substantially equal to that of the grooves, so that in their normal position their outer edges will be about flush with the periphery of the carrier. Instead of arranging the grooves for the indicators radial with respect to the supporting-shaft 22, as they might be, it is preferred to arrange them tangentially with respect thereto, in the manner shown.

In order to expose the indicators one by one in numerical order as the register is operated, many modes of moving or permitting the indicators to move for this purpose may be employed. As herein shown the indicator plates or tablets are held loosely between the disks of the carrier, so that at a certain portion of the circumference the indicator-tablets will tend to slide or move by gravity from their normal position outward, and in the rotation of the carrier it will be apparent that as the indicator-tablets arrive at this point in their travel they will each have the tendency to move outward in succession. This normal tendency of the tablets is utilized to effect the display of their indication. Thus the inclosing case immediately adjacent to and surrounding the carrier (see Figs. 3, 4, and 6) forms by its inner surface a guide E, that controls the position of the indicator-tablets with respect to the carrier, serving in the present instance also as a guide to return them to their normal positions. This guide E, as shown, surrounds the carrier and is concentric therewith for the greater portion of its circumference, and to a certain extent forms a guard for the indicators, so that they are inaccessible from the outside of the inclosing case. At a certain point below the carrier—preferably at a point coincident with a tangent vertical with respect to the horizontal axis of the carrier—the concentric portion of the guide abruptly terminates, so as to provide a pocket D, into which the indicator-tablets may extend in succession as the carrier is moved in the direction of the arrows, Figs. 3 and 4. The depth of the pocket beneath the carrier will be regulated according to the length of the indicator-tablets, so that when they are wholly free to move in and out of the carrier, as in the present instance, their outer edges will rest against the bottom of the pocket and their outward movement will be stopped before they entirely leave their grooves in the carrier, and thus they will always be in position to be readily moved back in their grooves to

their normal positions. As the carrier rotates it will be obvious, as the tablets never wholly leave it in dropping into the pocket, that they will be automatically returned by gravity in about one-quarter of a revolution; but in order to economize space it is preferred to gradually return the indicators positively to their normal position. Thus the inner face of the pocket forms an incline 18 and gradually approaches the periphery of the carrier, so that as the latter is rotated, carrying with it the indicator-tablets resting against this incline, they will be gradually moved positively toward the interior of the carrier and finally into their normal position, at which point the incline joins the concentric portion of the guide E, the whole forming a snail-shaped guide.

That portion of the inclosing case forming the front wall of the pocket D is cut away immediately in front of the extended indicator-tablet and fitted with a glass light 17, so that the indication borne by the indicator-tablet is exposed to view.

So far as the carrier and the indicating-tablets are concerned, any means for rotating or moving the former so as to bring the tablets to their exposed position in numerical order may be employed, that shown, however, being exceedingly simple and effective, is to be preferred. Thus the carrier is moved step by step by means of an actuating-dog 24, which engages with the teeth of a ratchet-wheel 23, that is secured to one side of the carrier. This dog is pivotally mounted to a vibrating arm or frame 25, that is loosely hung upon the shaft 22. The actuating-dog and its frame are vibrated by means of an operating-lever 33, that is pivoted at 34 to the rear of the inclosing case, (see Fig. 5,) and bears against a projection 26, forming part of the arm or frame 25. A suitable spring 27, one end held by a stud 19, projecting from the side of the frame and the other end bearing against the arm, returns the latter to its normal position against a stop 8 each time it is vibrated, and a suitable spring-pressed stop-pawl 29, mounted at the upper part of the frame, engages with the teeth of the ratchet-wheel and prevents any backward movement of the carrier.

The actuating dog 24 is held to duty against the teeth of the ratchet-wheel 23 by a spring, as usual. The forward end of the dog is provided with a projection 6, that as it is rocked in the act of moving the carrier forward lies and passes immediately over a shoulder 16, that forms part of the case, by which, as there is no room for any disengaging movement of the dog, the latter is temporarily locked to the teeth of the ratchet-wheel, so that any overmovement of the wheel is prevented. To cause a complete movement of the operating-lever each time it is vibrated, said lever carries a pivoted tooth 15, that is held in a central position with respect to the longitudinal axis of the lever by a spring 14, and attached

to the rear of the inclosing case in the path of the pivoted tooth 15 is a serrated or toothed plate 35, the function of which tooth and plate is, as the lever is vibrated and as the tooth 15 is rocked to one side by and passes over the toothed plate, the tooth will hold the lever should it be stopped at any point intermediate short of its complete vibration, so that in order to free the teeth from the serrations of the plate it is necessary that the tooth shall pass to the end of the plate, where it will be free to change its angle with respect to the lever, so that the lever may be moved in the opposite direction.

The audible alarm is provided by a bell 49, secured to the rear of the inclosing case, against which strikes a bell-hammer 41, that is pivotally mounted upon a stud 42, projecting from a portion of the case. The bell-hammer is provided with an arm 43, Figs. 4 and 8, rigidly connected to move with the hammer, and has a shoulder that extends in the path of a projection 13, formed on the actuating-dog. The arrangement of the parts is such that at the end of the forward movement of the actuating-dog and as it begins to return to its normal position, the projection 13 will bear against the shoulder of the arm 43, rock it and the hammer slightly on its pivot, and, suddenly leaving the shoulder, will allow the hammer to be forcibly brought against the bell by the power exerted by a spring 44. In order to return the carrier to its normal or starting position, so that the indicator bearing the "0" indication will be the one exposed, there is provided means for coupling the carrier to the shaft 22, so that by turning the latter the carrier may likewise be turned. There is also provided means by which the carrier as it is moved for the purpose will be positively stopped when it arrives at its normal or starting position, and there is furthermore provided a lock by which any attempt to operate the register is prevented when the parts are in position to turn the carrier to its normal starting-point.

The shaft 22 carries a disk 45, Figs. 3 and 6, that is rigidly connected thereto. The disk is provided with a spring-pressed coupling-pawl 46, that is adapted to engage with a recess formed in an integral portion of the carrier, as, for instance, in the hub 47. The shaft 22 and its disk 45 are held against movement by a locking-pawl 48, that is fixedly mounted at the end of a rock-shaft 49, that is held in bearings in the case. The pawl is held in duty by a spring 51, and, as shown, is provided with a long tooth, that in the normal position of the parts, as shown in Fig. 3, engages with a deep notch 50 in the disk, so that the said dog will resist any unusual attempt to rotate the shaft, and at the same time its shaft 49 will have been rocked to the required extent. The disk is also engaged by a spring-pressed supplemental pawl 52, that is pivoted to the inner side of one of the brackets 31, and is adapted to engage some

teeth 53, formed on the edge of the disk. The function of this pawl 52 is to prevent the shaft being rotated in the opposite direction when the pawl 48 has been raised from the disk. In the usual rotation of the carrier as it is moved step by step in the act of registering, the shoulder of its hub 47 will leave the dog 46 a distance equal to the extent to which the carrier has been rotated, so that when it is desired to return the carrier to its normal starting-point the shaft and its disk 45 will be rotated idly until the pawl 46, riding over the face of the hub 47, reaches its shoulder and engages therewith, so that upon the further rotation of the shaft and disk they will be coupled with the carrier and will move together in unison until the carrier arrives at its normal starting position, at which point the notch 50 of the disk will be in position, so that the pawl 48 may be engaged therewith to secure and hold it. The particular function of the disk 45 and its immediate connections are to lock the shaft 22 against movement until the proper time, and to provide means for coupling the shaft and carrier together.

In order to prevent the carrier from being moved beyond its normal starting-point, an arm 12 (see Fig. 4) is thrown into position to bear against a stud or projection 11, secured to the side of the carrier. The arm 12 (see Figs. 4, 6, and 9) is shown as mounted upon the rock-shaft 49, a spring 10 tending to throw it into its operative position. The shaft 49 also carries a stop-arm 54, that is rigidly connected thereto, and carries a pin 7, that overlies the arm 12 and holds it back in its idle position under the force of the spring 51, that tends to rock the shaft. The frame 25 is formed with a projection 55 in position to escape the arm 54 each time it is vibrated in the act of rotating the carrier. When the shaft 49 is rocked in the direction of the arrow, Fig. 4, sufficient to remove the locking-pawl from engagement with the notch 50 of the disk 45, the stop-arm 54 will be simultaneously rocked in front of the projection 55, so that the frame 25 is rendered immovable so long as the arm remains in that position. At the same time the shaft 49 is rocked to remove the locking-pawl 48, and to place the stop-arm 54 in position the pin 7 will be removed from contact with the arm 12, so that its spring will rock it into the position shown in dotted lines, Fig. 4, in the path of the stud 11. From this construction it results that whenever the disk 45 is rendered free to turn by the lifting of the locking-pawl a stop will be put into the path of the actuating-dog frame 25, so that it cannot be moved, and at the same time a stop (as the arm 12) is placed in position to extend into the path of a projection from the carrier and prevent the latter from being overturned in the act of moving it to its normal starting position. And it will also be seen that until the locking-pawl 48 is properly seated in the notch in the disk 45 the

parts will occupy the position just mentioned. So soon, however, as the locking-pawl engages with the notch 50 of the disk the shaft 49 will be rocked sufficiently to return the parts to their normal idle positions, permitting the frame 25 to be vibrated and the carrier to be rotated. Any convenient means of rocking the shaft 49 may be employed—as, for instance, by a hand-wheel 56, extending to the outside of the case—and the shaft 22 may be likewise turned by a hand-wheel 57.

The registering devices R employed with the improved register may be, obviously, of any construction, and as it forms no part of the present invention and the ordinary forms of it are so well known, no detailed illustration or particular description thereof is deemed necessary. It may be stated, however, that the dials are mounted upon a shaft 60, held in brackets 61, that extend from the case, and are actuated, primarily, through a ratchet 62, the teeth of which are engaged by a feeding-pawl 63, pivotally mounted to an extension 64 of the frame 25. A hold-back pawl 65, engaging with the ratchet 62, prevents any backward movement to said ratchet. From this construction it will be seen that with each vibration of the frame 25 to move the actuating-dog, the feeding-pawl 63 will likewise impart the desired movement to the dials of the register. The figures of the register R may be read through an opening 59 in the front wall of the case, and should it be desired to conceal the register by closing the opening, a shutter 66 may be employed for that purpose. This shutter consists of a plate extending the length of the dials and mounted to rock on the shaft 60. It is connected by a rod 67 to a permutation-lock 68, by turning which through its proper key the shutter may be moved to its closing position (shown in dotted lines, Fig. 3) and there locked upon the removal of the key.

It should be stated that the projection 13 of the actuating-dog rests behind a shoulder of arm 43, so that when the carrier is returned to its normal position the actuating-dog will vibrate on its pivot without actuating the bell-hammer, the dog and hammer being entirely independent, and when the frame moves forward the actuating-dog will pass into a tooth of the ratchet-wheel sufficient to allow the projection to escape the arm 43; but as the frame and dog return to their normal positions, the dog, vibrating over the ratchet-teeth, will bear against the arm sufficient to rock the bell-hammer, as is obvious.

With respect to the mode of operating the registering device R, the construction of the parts are such that the movement of the carrier to its normal starting position will in no way effect said register or means for operating it, as the frame 25 from which it is operated is locked against movement.

Instead of depending upon the inclosing case A to form the guide E for controlling the positions of the indicator-tablets with respect to the carrier, the said guide E (see Fig. 10) may be in the form of a cam arranged upon the side of the carrier, and against which bear pins 5, projecting from the indicator-tablets through slots 4 in the sides of the carrier. So, too, it is obvious that instead of allowing the tablets to fall by gravity into their exposed position, they may, as shown in Fig. 11, be forced upward into a recess or pocket by means of a fixed cam E', against which cam the pins 5 may bear in the rotation of the carrier, so that the indicator-tablets are forced positively outward, as will be clearly understood. Again, instead of mounting the indicator-tablets to slide in and out of the carrier, they may be, as shown in Fig. 12, mounted on pivots 3, so as to lie around the periphery of the carrier, and when the latter is moved and when their free edges pass the abrupt end of the guide E they will swing into their exposed positions into the pocket D.

Without then limiting the invention to the specific construction set forth, what is claimed is—

1. In a register, the combination of a movable carrier, a plurality of gravitating indicators supported thereby, a registering device adapted to register each time an indicator is exposed, a shaft, and means, substantially as described, for coupling the shaft and carrier together for moving the indicators to their initial starting position without disturbing the registering device, substantially as described.
2. In a register, the combination of a holder or carrier, a plurality of indicators supported thereby, and means for causing the indicators to move one by one in succession to their exposed position, a registering device adapted to register each time an indicator is exposed, a shaft, and means, substantially as described, for coupling the shaft and carrier together for moving the indicators to their initial starting position without disturbing the registering device, substantially as described.
3. In a register, the combination of the carrier, a plurality of indicators supported thereby and movable with respect to the carrier, and the guide for controlling the movements of said indicators, with the registering device adapted to register each time an indicator is exposed, substantially as described.
4. In a register, the combination of the carrier, a plurality of indicators mounted to slide in guides in the carrier, and the snail-shaped guide for controlling the position of the indicators with respect to the carrier, substantially as described.
5. In a register, the combination of the carrier, a plurality of gravitating indicators supported thereby, the snail-shaped guide having an abrupt termination for controlling the po-

sition of the indicators and allowing them to move to and return from their exposed position, substantially as described.

6. In a register, the combination of the carrier, a plurality of gravitating indicators supported thereby, the circumferential guide of snail shape for controlling the position of the indicators, and the pocket, into which the indicators may gravitate to their exposed position, substantially as described.

7. In a register, the combination of the carrier, a plurality of gravitating indicators supported thereby, the circumferential guide for controlling the position of the indicators, the pocket into which the indicators may gravitate to their exposed position, and the guide for positively returning the indicators to their normal positions, with the registering device adapted to register each time an indicator is exposed, substantially as described.

8. In a register, the combination of the carrier, a plurality of gravitating indicators supported thereby, the snail-shaped guide for controlling the position of the indicators, an actuating-dog for imparting a step-by-step movement to the carrier, the stop for locking the dog against movement, and means for turning the carrier to its normal starting position, substantially as described.

9. In a register, the combination of a carrier, a plurality of indicators supported thereby, a snail-shaped guide for controlling the position of the indicators, an actuating-dog for moving the carrier step by step, a stop for locking the dog against movement, an arm for limiting the movement of the carrier to its normal starting position, and means for moving the carrier to said position, substantially as described.

10. In a register, the combination of a carrier, a plurality of indicators supported thereby, a shaft for supporting the carrier, a dog for locking the shaft against movement, an actuating-dog for the carrier, means for coupling the shaft and carrier together, and means for releasing the shaft to permit the carrier to be moved to its normal starting position, substantially as described.

11. In a register, the combination of a carrier, a plurality of indicators supported thereby, a shaft for supporting the carrier, an actuating-dog for the carrier, a stop for locking the dog against movement, a locking-dog for the shaft, said stop and locking-dog mounted to move in unison, and means for coupling the shaft and carrier together, so that they may move in unison, substantially as described.

12. In a register, the combination of a carrier with operatively-connected and independently-movable indicators, a registering device adapted to register each time an indicator is exposed, an operating-arm and connections for effecting the display of an indicator and operating the registering device, and means, substantially as described, inde-

pendent of said operating-arm, and connections for moving the carrier and indicators to their initial starting position without disturbing the registering device, substantially as described.

13. In a register, the combination of a carrier, a plurality of indicators supported thereby, means for causing the indicators to move one by one in succession to their exposed positions, a registering device adapted to register each time an indicator is exposed, a single operating-arm and connections for effecting the display of an indicator and operating the registering device, and means, substantially as described, independent of said operating-arm and connections, for moving the carrier and indicators to their initial starting position without disturbing the registering device, substantially as described.

14. In a register, the combination of a carrier with operatively-connected and independently-movable indicators and a guide for controlling the same, a registering device adapted to register each time an indicator is exposed, and a single operating-arm and connections for effecting the display of an indicator and operating the registering device, substantially as described.

15. The combination of a carrier, a plurality of indicators supported thereby, means for causing the indicators to move in succession one by one to their exposed positions, a register, a vibrating frame, an actuating dog and pawl for moving the carrier and register, and means, substantially as described, independent of said vibrating frame and dog, for moving the carrier and indicators to their initial starting position without disturbing the registering device, substantially as described.

16. In a register, the combination of a carrier, a plurality of indicators supported thereby, the snail-shaped guide for controlling the position of the indicators, a vibrating frame having an actuating-dog for moving the carrier step by step, an independently-mounted bell-hammer vibrated directly by said actuating-dog, an operating-arm for actuating the frame, a stop for locking the dog against movement, and means for moving the carrier to its normal starting position, substantially as described.

In testimony whereof we have signed our names in the presence of two subscribing witnesses.

LEO EHRLICH.
JAMES A. KEYES.

Witnesses as to the signature of Leo Ehrlich:

J. M. THRILKELD,
O. S. FIELD.

Witnesses as to the signature of James A. Keyes:

GEO. H. GRAHAM,
JAMES R. TORRANCE.