



(12) **EUROPEAN PATENT APPLICATION**

(88) Date of publication A3:  
**01.03.2006 Bulletin 2006/09**

(51) Int Cl.:  
**G02F 1/1335<sup>(2006.01)</sup> G02F 1/13357<sup>(2006.01)</sup>**  
**G02F 1/13363<sup>(2006.01)</sup>**

(43) Date of publication A2:  
**06.07.2005 Bulletin 2005/27**

(21) Application number: **05075482.9**

(22) Date of filing: **26.01.1999**

(84) Designated Contracting States:  
**DE GB**

(30) Priority: **04.02.1998 JP 2365698**  
**05.06.1998 JP 15762298**

(62) Document number(s) of the earlier application(s) in accordance with Art. 76 EPC:  
**99900683.6 / 0 973 058**

(71) Applicant: **SEIKO EPSON CORPORATION**  
**Tokyo 160-0811 (JP)**

(72) Inventors:  
• **Maeda, Tsuyoshi**  
**Seiko Epson Corporation**  
**Suwa-shi**  
**Nagana-ken 392-8502 (JP)**

- **Eiji, Okamoto**  
**Seiko Epson Corporation**  
**Suwa-shi**  
**Nagana-ken 392-8502 (JP)**
- **Seki, Takumi**  
**Seiko Epson Corporation**  
**Suwa-shi**  
**Nagana-ken 392-8502 (JP)**
- **Okumura, Osamu**  
**Seiko Epson Corporation**  
**Suwa-shi**  
**Nagana-ken 392-8502 (JP)**

(74) Representative: **Cloughley, Peter Andrew et al**  
**Miller Sturt Kenyon,**  
**9 John Street**  
**London WC1N 2ES (GB)**

(54) **Liquid crystal device and electronic apparatus**

(57) When a backlight 15 is turned on in a dark environment, white light emerging from the surface of a light guide plate 15b passes through a polarizer 12 and a retardation film 14, enters the interior of the liquid crystal cell, passes through openings of reflective electrodes 7, and is introduced into a liquid crystal layer 3. The light introduced into the liquid crystal layer 3 passes through a color filter 5, emerges from the liquid crystal cell, and passes through the retardation film 13 and the polarizer 11 towards the exterior. In a lighted environment, the light incident on the polarizer 11 passes through the liquid crystal layer 3, is reflected by the reflective electrode 7, and passes through the polarizer 11 again and is emitted towards the exterior.

Fig. 1a

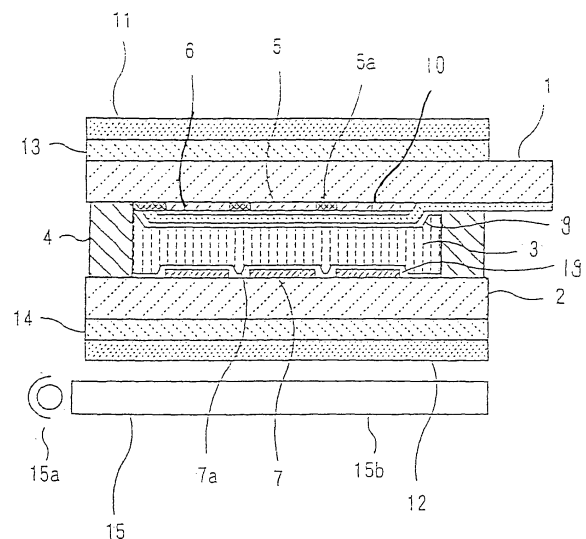



DOCUMENTS CONSIDERED TO BE RELEVANT			
Category	Citation of document with indication, where appropriate, of relevant passages	Relevant to claim	CLASSIFICATION OF THE APPLICATION (IPC)
A	PATENT ABSTRACTS OF JAPAN vol. 1996, no. 04, 30 April 1996 (1996-04-30) -& JP 07 318929 A (CASIO COMPUT CO LTD), 8 December 1995 (1995-12-08) * abstract; figures 1,2 *	1	G02F1/1335 G02F1/13357 G02F1/13363
A	PATENT ABSTRACTS OF JAPAN vol. 017, no. 461 (P-1598), 23 August 1993 (1993-08-23) & JP 05 107548 A (CANON INC), 30 April 1993 (1993-04-30) * abstract *	1	
			TECHNICAL FIELDS SEARCHED (IPC)
			G02F
The present search report has been drawn up for all claims			
Place of search The Hague		Date of completion of the search 11 January 2006	Examiner Gill, R
CATEGORY OF CITED DOCUMENTS X : particularly relevant if taken alone Y : particularly relevant if combined with another document of the same category A : technological background O : non-written disclosure P : intermediate document		T : theory or principle underlying the invention E : earlier patent document, but published on, or after the filing date D : document cited in the application L : document cited for other reasons ..... & : member of the same patent family, corresponding document	

2  
EPO FORM 1503 03.02 (P04C01)

**ANNEX TO THE EUROPEAN SEARCH REPORT  
ON EUROPEAN PATENT APPLICATION NO.**

EP 05 07 5482

This annex lists the patent family members relating to the patent documents cited in the above-mentioned European search report. The members are as contained in the European Patent Office EDP file on the above-mentioned patent documents. The European Patent Office is in no way liable for these particulars which are merely given for the purpose of information.

11-01-2006

Patent document cited in search report	Publication date	Patent family member(s)	Publication date
JP 07318929 A	08-12-1995	NONE	
JP 05107548 A	30-04-1993	JP 2869829 B2	10-03-1999

EPO FORM P0459

For more details about this annex : see Official Journal of the European Patent Office, No. 12/82