



- (51) International Patent Classification:
B62D 55/21 (2006.01) B62D 55/28 (2006.01)
B62D 55/20 (2006.01)
- (21) International Application Number:
PCT/US2013/048755
- (22) International Filing Date:
28 June 2013 (28.06.2013)
- (25) Filing Language: English
- (26) Publication Language: English
- (30) Priority Data:
61/666,867 30 June 2012 (30.06.2012) US
- (71) Applicant: GAMBLIT GAMING LLC [US/US]; 620 North Brand Boulevard, Suite 500, Glendale, CA 91203 (US).
- (72) Inventors: ARNONE, Miles; C/O Gamblit Gaming, LLC, 620 North Brand Boulevard, Suite 500, Glendale, CA 91203 (US). ROSS, Caitlyn; C/O Gamblit Gaming, LLC,

620 North Brand Boulevard, Suite 500, Glendale, CA 91203 (US).

(74) Agent: CIRE, Frank; C/O Gamblit Gaming, LLC, 620 North Brand Boulevard, Suite 500, Glendale, CA 91203 (US).

(81) Designated States (unless otherwise indicated, for every kind of national protection available): AE, AG, AL, AM, AO, AT, AU, AZ, BA, BB, BG, BH, BN, BR, BW, BY, BZ, CA, CH, CL, CN, CO, CR, CU, CZ, DE, DK, DM, DO, DZ, EC, EE, EG, ES, FI, GB, GD, GE, GH, GM, GT, HN, HR, HU, ID, IL, IN, IS, JP, KE, KG, KN, KP, KR, KZ, LA, LC, LK, LR, LS, LT, LU, LY, MA, MD, ME, MG, MK, MN, MW, MX, MY, MZ, NA, NG, NI, NO, NZ, OM, PA, PE, PG, PH, PL, PT, QA, RO, RS, RU, RW, SC, SD, SE, SG, SK, SL, SM, ST, SV, SY, TH, TJ, TM, TN, TR, TT, TZ, UA, UG, US, UZ, VC, VN, ZA, ZM, ZW.

(84) Designated States (unless otherwise indicated, for every kind of regional protection available): ARIPO (BW, GH, GM, KE, LR, LS, MW, MZ, NA, RW, SD, SL, SZ, TZ, UG, ZM, ZW), Eurasian (AM, AZ, BY, KG, KZ, RU, TJ,

[Continued on next page]

(54) Title: COINCIDENT GAMBLING HYBRID GAME

(57) Abstract: Systems and method for providing a coincident gambling hybrid game having coincident gambling and game events is disclosed. The systems and method involve receive an input from a player. An action event in the game is then determined from the input. A gambling event that is associated with the action event is then determined. Any wagers on the gambling event are also. The results of the gambling event are then determined and the wagers are resolved. A random outcome used to determine a result of the gambling event are then used to change variables in a set of game variables and are applied in the game.

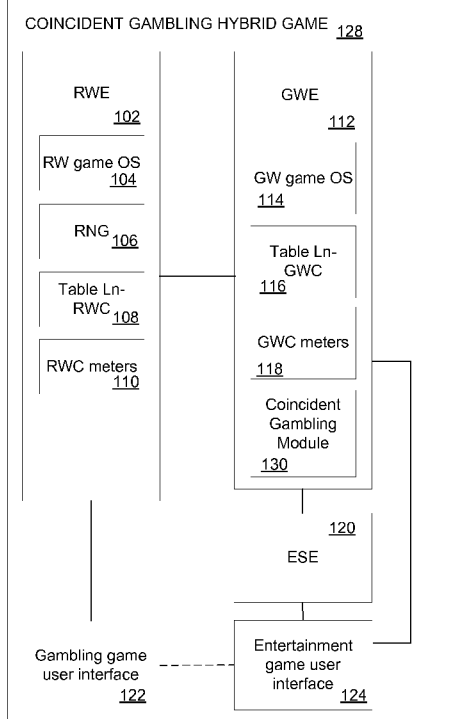

FIG. 1

WO 2014/005115 A2

TM), European (AL, AT, BE, BG, CH, CY, CZ, DE, DK, EE, ES, FI, FR, GB, GR, HR, HU, IE, IS, IT, LT, LU, LV, MC, MK, MT, NL, NO, PL, PT, RO, RS, SE, SI, SK, SM, TR), OAPI (BF, BJ, CF, CG, CI, CM, GA, GN, GQ, GW, KM, ML, MR, NE, SN, TD, TG).

Published:

— *without international search report and to be republished upon receipt of that report (Rule 48.2(g))*

COINCIDENT GAMBLING HYBRID GAME

CROSS-REFERENCE TO RELATED APPLICATIONS

[0001] The current application claims priority to US Provisional Application No. 61/666,867, filed June 30, 2012, the disclosure of which is incorporated herein by reference as if set forth herewith. The current application is also related to PCT Applications: PCT/US11/26768 filed March 1, 2011; PCT/US11/63587 filed December 6, 2011; PCT/US12/32652, filed April 7, 2012; PCT/US12/40548 filed June 1, 2012; and PCT/US12/40800 filed June 4, 2012, all of which are incorporated by reference as if set forth herewith. The current application is further related to US Provisional Patent Applications: 61/459,131 filed December 6, 2010; 61/460,362 filed December, 31 2012; and 61/574,753 filed August 9, 2011, all of which are incorporated by reference as if set forth herewith.

FIELD OF THE INVENTION

[0002] Embodiments of the present invention are generally related to gaming and more specifically to systems and processes that provide a random number generator that feeds a process that may dictate a gambling game result and trigger a process that affects one or more variables with an entertainment game.

BACKGROUND OF THE INVENTION

[0003] The gaming machine manufacturing industry provides a variety of gaming machines to enable wagering for interested parties whilst providing an entertainment experience. An exemplary gaming machine is a slot machine. As the demographic of eligible players has shifted with time to newer generations who have grown accustomed to highly sophisticated graphics and interactive video games, a need has arisen to increase the entertainment content present on a gaming machine to keep it relevant, at least to a growing portion of a casino's patronage. The subject design is a form of gaming machine, designed for use in a physical or virtual casino environment, which provides players an environment in which to play for cash, prizes and points, either against the casino or in head to head modes in a controlled and regulated manner while

being allowed to use their skills and adeptness at a particular type of entertainment game. An example of such an entertainment game would be a challenging word spelling game, or an interactive action game such as is found on video game consoles popular today, such as a PlayStation®, an Xbox®, a Wii® or a PC based.

SUMMARY OF THE INVENTION

[0004] Systems and methods in accordance with embodiments of the invention provide a coincident gambling hybrid game having coincident gambling and game events provided on a computing device. In accordance with some embodiments, the coincident gambling hybrid game is provided in the following manner. An entertainment engine constructed to execute an entertainment game receives a player input. An action event in the entertainment game based on the player input is determined using the entertainment engine. The action event is provided by the entertainment engine to a game world engine that constructed to manage the entertainment engine. The game world engine determines a gambling event associated the action event and requests a resolution of the gambling event from a real world engine that is constructed to resolve gambling events and maintain real world credits for a player. The real world engine determines a random outcome and uses the random outcome to determine a result of the gambling event. The random outcome is then provided to the game world engine. The game world engine determines changes to a set of game variables based on the random outcome and provides the changes to the set of game variables to the entertainment engine. The entertainment engine incorporates the changes in the set of game variables into the entertainment game using the entertainment engine.

[0005] In accordance with some these embodiments, the determining of the gambling event associated with an action event by the game world engine is based upon the action event and a result of a previous gambling event. In accordance with some of these embodiments of the invention, the random outcome of the gambling event is stored in a database by the game world engine. In accordance with other embodiments of the invention, the result of the gambling event is stored in in a database accessible by the game world engine using the real world engine.

[0006] In accordance with some embodiments of the invention, the real world engine determines the result of the gambling event in the following manner. The real world engine generates random number information using a random number generator to determine result of the gambling event and provides the random number information to the game world engine as part of the result of the gambling event. In accordance with some embodiments of the invention, the real world engine selects one of a set of random number generators in the real world engine to use to generate the random number information based upon the gambling event. In accordance with some embodiments of the invention, the real world engine determines one of a set of pay tables to use to resolve a wager on the gambling event based upon the gambling event.

BRIEF DESCRIPTION OF THE DRAWINGS

[0005] FIG. 1 illustrates a conceptual diagram of components of a coincident gambling hybrid game in accordance with an embodiment of the invention.

[0006] FIG. 2 is a system diagram that illustrates an implementation of a network distributed coincident gambling hybrid game including a game world engine local server in accordance with an embodiment of the invention.

[0007] FIG. 3 illustrates a representative state diagram that illustrates an implementation of a network distributed coincident gambling hybrid game in accordance with an embodiment of the invention.

[0008] FIG. 4 illustrates a system diagram of an implementation of a network based coincident gambling hybrid game in accordance with an embodiment of the invention.

[0009] FIG. 5 illustrates a system diagram of an implementation of a network based coincident gambling hybrid game in accordance with another embodiment of the invention.

[0010] FIG. 6 illustrates a system diagram of an implementation of an Internet based coincident gambling hybrid game in accordance with an embodiment of the invention.

[0011] FIG. 7 illustrates a block diagram of components of a device implementing a coincident gambling hybrid game in accordance with an embodiment of the invention.

[0012] FIG. 8 illustrates a conceptual diagram of the interaction between components for a system providing a coincident gambling hybrid game having coincident gambling and game events in accordance with embodiments of the invention.

[0013] FIG. 9 illustrates a conceptual diagram of the interaction between components for a system providing a coincident gambling hybrid game having coincident gambling and game events in accordance with other embodiments of the invention.

[0014] FIG. 10 illustrates a conceptual diagram of the interaction between components for a system providing a coincident gambling hybrid game having coincident gambling and game events in accordance with still other embodiments of the invention.

[0015] FIG. 11 illustrates a timing diagram of information passed between components of a system providing a coincident gambling hybrid game having coincident gambling and game events in accordance with embodiments of the invention.

[0016] FIG. 12 illustrates a flow diagram of a process performed by an Entertainment System Engine to provide a coincident gambling hybrid game having coincident gambling and game events in accordance with embodiments of the invention.

[0017] FIG. 13 illustrates a flow diagram of a process performed by a Game World Engine to provide a coincident gambling hybrid game having coincident gambling and game events in accordance with embodiments of the invention.

[0018] FIG. 14 illustrates a flow diagram of a process performed by Real World Engine to provide a coincident gambling hybrid game having coincident gambling and game events in accordance with embodiments of the invention.

DETAILED DISCLOSURE OF THE INVENTION

[0019] Turning now to the drawings, a coincident gambling hybrid game that provides coincident gambling and game events in accordance with embodiments of the invention is disclosed. In operation, the system uses an RNG which feeds a process that may dictate a gambling game result at the same time it triggers a process that affects one or more variables within the entertainment game. Thus, an action in the entertainment game may both affect the play of the entertainment game and provide an opportunity to wager an outcome of the action.

Coincident gambling hybrid games

[0020] In accordance with many embodiments of the invention, a coincident gambling hybrid game integrates high-levels of entertainment content with a game of skill (entertainment game) and a gambling experience with a game of chance (gambling event). A coincident gambling hybrid game provides for random outcomes independently of player skill while providing that the player's gaming experience (as measured by obstacles/challenges encountered, time of play and other factors) is shaped by the player's skill. The outcome of a gambling event is determined on the partial basis of a random outcome of random number information generated by a Random Number Generator (RNG) or other such device that provides random number information generated from a source of random numbers or from a pseudo random number generation process. Once the random outcome has been determined, it may be used in conjunction with a paytable to determine how many real world credits a player has won based on the random outcome. In accordance with some embodiments, the gambling event may be initiated in response to a game object related player action. A coincident gambling hybrid game in accordance with an embodiment of the invention is illustrated in FIG. 1. The coincident gambling hybrid game 128 includes a Real World Engine (RWE) 102, a Game World Engine (GWE) 112, an Entertainment System Engine (ESE) 120, a gambling game player interface 122 and an entertainment game player interface 124. The two player interfaces can be part of the same player interface but are separate in the illustrated embodiment. The RWE 102 is connected with the GWE 112 and the gambling game player interface 122. The ESE 120 is connected with the GWE 112 and the entertainment game player interface 124. The GWE 112 is connected also with the entertainment game player interface 124.

[0021] In accordance with several embodiments, the RWE 102 is an operating system for the gambling game of the coincident gambling hybrid game 128 and controls and operates the gambling game. The operation of a gambling game is enabled by Real World Currency (RWC), such as money or other real world funds. A gambling game can increase or decrease an amount of RWC based on random gambling outcomes, where the gambling proposition of a gambling event is typically regulated by gaming control bodies. In many embodiments, the RWE includes a Real World (RW) operating system (OS) 104, RNG 106, level n real-world credit pay tables (table Ln-

RWC) 108, RWC meters 110 and other software constructs that enable a game of chance to offer a fair and transparent gambling proposition, and to contain the auditable systems and functions that can enable the game to obtain gaming regulatory body approval.

[0022] A random number generator (RNG) 106 includes software and/or hardware algorithms and/or processes, which are used to generate random outcomes. A level n real-world credit pay table (table Ln-RWC) 108 is a table that can be used in conjunction with a random number generator (RNG) 106 to dictate the RWC earned as a function of sponsored gameplay and is analogous to the pay tables used in a conventional slot machine. Table Ln-RWC payouts are independent of player skill. There can be one table or multiple tables included in Ln-RWC pay tables 108 contained in a gambling game, the selection of which can be determined by factors including (but not limited to) game progress that a player has earned, and/or bonus rounds for which a player can be eligible. RWCs are credits analogous to slot machine game credits, which are entered into a gambling game by the player, either in the form of money such as hard currency or electronic funds. RWCs can be decremented or augmented based on the outcome of a random number generator according to the table Ln-RWC real world credits pay table 108, independent of player skill. In certain embodiments, an amount of RWC can be used as criteria in order to enter higher ESE game levels. RWC can be carried forward to higher game levels or paid out if a cash out is opted for by a player. The amount of RWC used to enter a specific level of the game level n need not be the same for each level.

[0023] In accordance with some embodiments, the GWE 112 manages the overall coincident gambling hybrid game operation, with the RWE 102 and the ESE 120 effectively being support units to the GWE 112. In accordance with some of these embodiments, the GWE 112 contains mechanical, electronic, and software systems for an entertainment game. The GWE 112 includes an operating system (OS) 114 that provides control of the entertainment game. The GWE additionally contains a level n game world credit pay table (table Ln-GWC) 116 from where to take input from this table to affect the play of the entertainment game. The GWE 112 can further couple to the RWE 102 to determine the amount of RWC available on the game and other metrics

of wagering on the gambling game (and potentially affect the amount of RWC in play on the RWE). The GWE additionally contains various audit logs and activity meters (such as the GWC meter) 118. The GWE 112 can also couple to a centralized server for exchanging various data related to the player and their activities on the game. The GWE 112 furthermore couples to the ESE 120. In some embodiments, the GWE includes a coincident gambling module 130 to facilitate implementation of a coincident gambling hybrid game as described herein.

[0024] In accordance with some embodiments, a level n game world credit pay table (Table Ln-GWC) 116 dictates the Game World Credit (GWC) earned as a function of player skill in the nth level of the game. The payouts governed by this table are dependent upon player skill and sponsored gameplay at large and can or cannot be coupled to a RNG. In accordance with some embodiments, GWCs are player points earned or depleted as a function of player skill, specifically as a function of player performance in the context of the game. GWC is analogous to the score in a typical video game. Each entertainment game has one or more scoring criterion, embedded within the table Ln-GWC 116 that reflects player performance against the goal(s) of the game. GWCs can be carried forward from one level of sponsored gameplay to another, and ultimately paid out in various manners such as directly in cash, or indirectly such as by earning entrance into a sweepstakes drawing, or earning participation in, or victory in, a tournament with prizes. GWCs can be stored on a player tracking card or in a network-based player tracking system, where the GWCs are attributed to a specific player.

[0025] In accordance with certain embodiments, the operation of the GWE does not affect the RWE's gambling operation except for player choice parameters that are allowable in slot machines, including but not limited to, wager terms such as, but not limited to, a wager amount, how fast the player wants to play (by pressing a button or pulling the handle of a slot machine), and/or agreement to wager into a bonus round. In this sense, the RWE 102 provides a fair and transparent, non-skill based gambling proposition co-processor to the GWE 112. In the illustrated embodiment, the communication link shown between the GWE 112 and the RWE 102 allows the GWE 112 to obtain information from the RWE 102 as to the amount of RWC available in the

gambling game. The communication link can also convey a status operation of the RWE (such as on-line or tilt). The communication link can further communicate the various gambling control factors which the RWE 102 uses as input, such as the number of RWC consumed per game or the player's election to enter a jackpot round. In FIG. 1, the GWE 112 is also shown as connecting to the player's player interface directly, as this can be utilized to communicate certain entertainment game club points, player status, control the selection of choices and messages which a player can find useful in order to adjust the entertainment game experience or understand their gambling status in the RWE 102.

[0026] In accordance with various embodiments of the invention, the ESE 120 manages and controls the visual, audio, and player control for the entertainment game. In accordance with certain embodiments, the ESE 120 accepts input from a player through a set of hand controls, and/or head, gesture, and/or eye tracking systems and outputs video, audio and/or other sensory output to a player interface. In accordance with many embodiments, the ESE 120 can exchange data with and accept control information from the GWE 112. In accordance with some of these embodiments, an ESE 120 can be implemented using a personal computer (PC), a Sony PlayStation® (a video game console developed by Sony Computer Entertainment of Tokyo Japan), or Microsoft Xbox® (a video game console developed by Microsoft Corporation of Redmond, Washington) running a specific entertainment game software program. In accordance with some of these embodiments, ESE 120 can be an electromechanical game system of a draw certificate based coincident gambling hybrid game that is an electromechanical hybrid game. An electromechanical hybrid game executes an electromechanical game for player entertainment. The electromechanical game can be any game that utilizes both mechanical and electrical components, where the game operates as a combination of mechanical motions performed by at least one player or the electromechanical game itself. Various electromechanical hybrid games are discussed in Patent Cooperation Treaty Application No. PCT/US12/58156, filed September 29, 2012, the contents of which are hereby incorporated by reference in their entirety.

[0027] The ESE 120 operates mostly independently from the GWE 112, except that via the interface, the GWE 112 can send certain entertainment game control parameters and elements to the ESE 120 to affect its play, such as (but not limited to) what level of character to be using, changing the difficulty level of the game, changing the type of gun or car in use, and/or requesting potions to become available or to be found by the character. These game control parameters and elements can be based on a gambling outcome of a gambling game that was triggered by an element in the entertainment game being acted upon by the player. The ESE 120 can accept this input from the GWE 112, make adjustments, and continue entertainment game gameplay all the while running seamlessly from the player's perspective. The ESE's operation is mostly skill based, except for where the ESE's processes can inject complexities into the game by chance in its normal operation to create unpredictability in the entertainment game. Utilizing this interface, the ESE 120 can also communicate player choices made in the game to the GWE 112, such as but not limited to selection of a different gun, and/or the player picking up a special potion in the GW environment. The GWE's function in this architecture, being interfaced with the ESE 120, is to allow the transparent coupling of entertainment software to a fair and transparent random chance gambling game, providing a seamless perspective to the player that they are playing a typical popular entertainment game (which is skill based). In accordance with certain embodiments, the ESE 120 can be used to enable a wide range of entertainment games including but not limited to popular titles from arcade and home video games, such as but not limited to Gears of War (a third person shooter game developed by Epic Games of Cary, North Carolina), Time Crisis (a shooter arcade game developed by Namco Ltd of Tokyo, Japan), or Madden Football (an American football video game developed by EA Tiburon of Maitland, Florida). Providers of such software can provide the previously described interface by which the GWE 120 can request amendments to the operation of the ESE software in order to provide seamless and sensible operation as both a gambling game and an entertainment game.

[0028] In accordance with some embodiments, the RWE 102 can accept a trigger to run a gambling game in response to actions taken by the player in the entertainment game as conveyed by the ESE 120 to the GWE 112, or as triggered by the GWE 112

based on its algorithms, background to the overall game from the player's perspective, but can provide information to the GWE 112 to expose the player to certain aspects of the gambling game, such as (but not limited to) odds, amount of RWC in play, and amount of RWC available. The RWE 102 can accept modifications in the amount of RWC wagered on each individual gambling try, or the number of gambling games per minute the RWE 102 can execute, entrance into a bonus round, and other factors, all the while these factors can take a different form than that of a typical slot machine. An example of a varying wager amount that the player can choose can include, but is not limited to, gameplay with a more powerful character, a more powerful gun, or a better car. These choices can increase or decrease the amount wagered per individual gambling game, in the same manner that a standard slot machine player can decide to wager more or less credits for each pull of the handle. In accordance with some of these embodiments, the RWE 102 can communicate a number of factors back and forth to the GWE 112, via an interface, such increase/decrease in wager being a function of the player's decision making as to their operational profile in the entertainment game (such as but not limited to the power of the character, gun selection or car choice). In this manner, the player is always in control of the per game wager amount, with the choice mapping to some parameter or component that is applicable to the entertainment game experience of the hybrid game. In accordance with a particular embodiment, the RWE 102 operation can be a game of chance as a gambling game running every 10 seconds where the amount wagered is communicated from the GWE 112 as a function of choices the player makes in the operation profile in the entertainment game.

[0029] In many embodiments, a coincident gambling hybrid game integrates a video game style gambling machine, where the gambling game (including an RWE 102 and RWC) is not player skill based, while at the same time allows players to use their skills to earn club points which a casino operator can translate to rewards, tournament opportunities and prizes for the players. The actual exchange of monetary funds earned or lost directly from gambling against a game of chance in a gambling game, such as a slot machine, is preserved. At the same time, a rich environment of rewards to stimulate gamers can be established with the entertainment game. In accordance with some of these embodiments, the coincident gambling hybrid game can leverage

very popular titles with gamers and provides a sea change environment for casinos to attract players with games that are more akin to the type of entertainment that a younger generation desires. In accordance with various embodiments, players can use their skill towards building and banking GWC that in turn can be used to win tournaments and various prizes as a function of their gamer prowess. Numerous embodiments minimize the underlying changes needed to the aforementioned entertainment software for the hybrid game to operate within an entertainment game construct, thus making a plethora of complex game titles and environments, rapid and inexpensive to deploy in a gambling environment.

[0030] In accordance with some embodiments, coincident gambling hybrid games also allow players to gain entry into subsequent competitions through the accumulation of game world credits (GWC) as a function of the player's demonstrated skill at the game. These competitions can pit individual players or groups of players against one another and/or against the casino to win prizes based upon a combination of chance and skill. These competitions can be either asynchronous events, whereby players participate at a time and/or place of their choosing, or they can be synchronized events, whereby players participate at a specific time and/or venue.

[0031] In accordance with some embodiments, one or more players engage in playing an entertainment game, resident in the ESE, the outcomes of which are dependent at least in part on skill. The coincident gambling hybrid game can include an entertainment game that includes head to head play between a single player and the computer, between two or more players against one another, or multiple players playing against the computer and/or each other, as well as the process by which players bet on the outcome of the entertainment game. The entertainment game can also be a game where the player is not playing against the computer or any other player, such as in games where the player is effectively playing against himself or herself (such as but not limited to Solitaire and Babette).

[0032] In accordance with some embodiments, a player can interact with a coincident gambling hybrid game by using RWC in interactions with a gambling game along with GWC and elements in interactions with an entertainment game. The gambling game can be executed by a RWE while an entertainment game can be

executed with an ESE and managed with a GWE. A conceptual diagram that illustrates how resources such as GWC, RWC and elements, such as but not limited to Entertainment Elements (EE), are utilized in a coincident gambling hybrid game in accordance with an embodiment of the invention is illustrated in FIG. 2. The conceptual diagram illustrates that RWC 204, EE 208 and GWC 206 can be utilized by a player 202 in interactions with the RWE 210, GWE 212 and ESE 214 of a draw certificate based coincident gambling hybrid game²¹⁶. The contribution of elements, such as EE 208, can be linked to a player's access to credits, such as RWC 204 or GWC 206. Electronic receipt of these credits can come via a smart card, voucher or other portable media, or as received over a network from a server. In accordance with certain embodiments, these credits can be drawn on demand from a player profile located in a database locally on a coincident gambling hybrid game or in a remote server.

[0033] A conceptual diagram that illustrates interplay between elements and components of a coincident gambling hybrid game in accordance with an embodiment of the invention is illustrated in FIG. 3. Similar to FIG. 2, a player's actions and/or decisions can affect functions 306 that consume and/or accumulate GWC 302 and/or EE 304 in an entertainment game executed by an ESE 310. A GWE 312 can monitor the activities taking place within an entertainment game executed by an ESE 310 for gameplay gambling event occurrences. The GWE 312 can also communicate the gameplay gambling event occurrences to an RWE 314 that triggers a wager of RWC 316 in a gambling game executed by the RWE 314.

[0034] In accordance with some embodiments of the invention, the following may occur during use of the coincident gambling hybrid game. The player enters an input that represents an action or decision (350). The ESE 310 signals the GWE 312 with the input decision or action (352). The GWE 312 responds by signaling to ESE 310 with the amount of EE that is consumed by the player action or decision (354). The signaling from the GWE 312 configures a function 306 to control the EE consumption, decay, and/or accumulation.

[0035] The ESE 310 then adjusts the EE 304 accordingly (356). The GWE 312 signals the RWE 314 as to the profile of the wager proposition associated with the action or decision and triggers the wager (358). The RWE 314 consumes the

appropriate amount of RC 316 and executes the wager (360). The RWE 314 then adjusts the RC 316 based upon the outcome of the wager (362) and informs the GWE 312 as to the outcome of the wager (364).

[0036] The GWE 312 signals the ESE 310 to adjust EE to one or more of the EEs of the ESE entertainment game (366). Function 306 of the ESE 310 performs the adjustment of EE 304 (368). The ESE 310 signals the GWE 312 as to the updated status (370). In response, the GWE 312 signals the ESE 310 to update GWC of the entertainment game. The ESE updates the GWC using a function 306 (372).

[0037] The following is an example of the above flow in a first person shooter game, such a Call of Duty ®, using a coincident gambling hybrid game sequence in accordance with embodiments of the invention.

[0038] The process begins by a player selecting a machine gun to use in the game and then fires a burst of bullets at an opponent (350). The ESE 310 signals the GWE 312 of the player's choice of weapon, that a burst of bullets was fired, and the outcome of the burst (352). GWE 312 processes the information received and signals ESE 310 to consume 3 bullets (EE) with each pull of the trigger (354). The ESE 310 consumes 3 bullets for the burst using function 306 (356).

[0039] The GWE 312 signals the RWE 314 that 3 credits (RC) are to be wagered to match the three bullets consumed. The RWE 314 then obtains a draw certificate from a draw server or the like as discussed further below and determines the result of the wager and may determine the winnings from a pay table. On a particular pay table (Table Ln-RC), a determination is made by RWE 314 as to the amount of damage that the opponent has sustained. The RWE 314 consumes 3 credits of RC 316 for the wager and executes the specified wager (360). The RWE 314 determines that the player hit a jackpot of 6 credits and returns the 6 credits to the RC 316 (362) and signals the GWE 312 that 3 net credits were won by the player (364).

[0040] The GWE 312 signals ESE 310 to add 3 bullets to an ammunition clip (366). ESE 310 adds 3 bullets back to the ammo clip (EE 304) using a function 306 (368). The ammunition may be added by directly adding the ammunition to the clip or by allowing the player to find extra ammunition during game play. The GWE 312 logs the new player score (GWC 302) in the game (as a function of the successful hit on the

opponent) based on the ESE 310 signaling, and the signals the ESE 310 to add 2 extra points to the player score since a jackpot has been won (370). The ESE 310 then adds 10 points to the player score (GWC 302) given the success of the hit which in this example is worth 8 points, plus the 2 extra points requested by GWE 312 (372). Note that the foregoing example is only intended to provide an illustration of how credits flow in a coincident gambling hybrid game, but is not intended to be exhaustive and only lists only one of numerous possibilities of how a coincident gambling hybrid game may be configured to manage its fundamental credits.

Network Based Coincident gambling hybrid game

[0041] A system diagram that illustrates an implementation of a network distributed coincident gambling hybrid game with a GWE local server in accordance with embodiments of the invention is illustrated in FIG. 4. The system includes several coincident gambling hybrid games 406 sharing services from the same GWE local server 402 over a network. The system includes several coincident gambling hybrid games 406 sharing services from the same GWE local server 402 over a network. Coincident gambling hybrid game 412 is a particular implementation where the coincident gambling hybrid game is implemented on a mobile device connected to the network via a wireless connection. The remaining coincident gambling hybrid games 406 can be implemented on any device, including laptops, desktop computers, mobile phones, tablets or the like over a network connection. A single coincident gambling hybrid game 406 with a RWE 410, ESE 408 and GWE 402 is enclosed within a dotted line. A number of other peripheral systems, such as , but not limited to, legacy patron management server 452, client management server 454, regulatory compliance server 456, and hybrid game player account management server 458 can also interface with the game object coincident gambling hybrid games over a network within an operator's firewall 804. Other servers can reside outside the bounds of a network within an operator's firewall 404 to provide additional services for network connected game object coincident gambling hybrid games. Examples of such servers, include, but are not limited to taxation authority server 460 and ESE hosting server 462. One skilled in the art will recognize that although these systems are represented as one server that one or

more connected servers or other processing systems may provide the same function without departing from this invention.

[0042] A system diagram that illustrates an implementation of a network distributed hybrid game with a GWE local server and a GWE group server in accordance with embodiments of the invention is illustrated in FIG. 5. The system includes several coincident gambling hybrid games 506 sharing services from the same GWE local server 528 over a network. Coincident gambling hybrid game 512 is a particular implementation where the coincident gambling hybrid game is implemented on a mobile device connected to the network via a wireless connection. The remaining coincident gambling hybrid games 506 can be implemented on any device, including laptops, desktop computers, mobile phones, tablets or the like over a network connection. A single coincident gambling hybrid game 506 with a RWE 510, ESE 508 and GWE 528 is enclosed within a dotted line. This system includes a coincident gambling hybrid game 508 that includes a RWE 512, ESE 510 and GWE local server 504 as shown enclosed within a dotted line but where a single coincident gambling hybrid game can call upon services from servers within an operator's firewall 506 (such as, but not limited to, a GWE local server 504) as well as beyond an operator's firewall 506 (such as, but not limited to, a GWE group server 502). The GWE group server 502 can coordinate multiple coincident gambling hybrid games from across a network that spans beyond an operator's firewall 506. A GWE server system 518 can include multiple GWE servers, such as, but not limited to, a GWE local server 504 and a GWE group server 502. Multiple network connected hybrid games 506 can be connected to various servers to call upon services that enable the execution of the hybrid game. These servers include but are not limited to client management server 552 and legacy patron management server 554 within the casino firewall 506; and regulatory compliance server 556, hybrid game account management server 558, taxation authority server 560 and ESE hosting server 562 outside the casino firewall 506. One skilled in the art will recognize that servers may be single servers or a group of servers and processing systems providing the services without departing from this invention; and that the servers described may be within or outside of casino firewall 506 without departing from this invention.

[0043] A system diagram that illustrates an implementation of network distributed

hybrid games over the Internet in accordance with an embodiment of the invention is illustrated in FIG. 6. The system includes an ESE server 602, GWE server 604 and RWE server 606 that each connect to a player interface 610 (such as, but not limited to, a television screen, computer terminal, tablet, touchscreen or PDA) of game object coincident gambling hybrid games over the Internet 608. Each coincident gambling hybrid game includes a local ESE 612 (such as, but not limited to, a video game console or a gaming computer system) that interfaces with a remote ESE server 602. Processes performed by an ESE 616 services can be performed in multiple locations, such as, but not limited to, remotely on an ESE server 602 and locally on a local ESE 612. In addition, a coincident gambling hybrid game may include a Personal Digital Assistant (PDA) 614 or other type of mobile computing device game coupled to the ESE hosting server 602, thus providing the opportunity for a player to play a hybrid game on the PDA through a mobile phone or data network.

[0044] There are many possible permutations of the architecture of systems for providing a coincident gambling hybrid game in accordance with embodiments of the invention. FIGS. 4-6 show only three possible permutations and are provided as examples which are not intended to suggest limitations to the forms of the architecture. Other permutations might include a version where the entire coincident gambling hybrid game is in the cloud with only a client running on player terminal within the bounds of the casino, or a permutation where the RWE and GWE are casino bound and the ESE exists in the cloud, accessed by a client running on a terminal in the casino.

Processing Apparatuses

[0045] Any of a variety of processing apparatuses can host various components of a coincident gambling hybrid game in accordance with embodiments of the invention. In accordance with embodiments of the invention, these processing apparatuses can include, but are not limited to, a gaming machine, a general purpose computer, a computing device and/or a controller. A processing apparatus that is constructed to implement a coincident gambling hybrid game in accordance with embodiments of the invention is illustrated in FIG. 7. In the processing apparatus 700, a processor 704 is coupled to a memory 706 by a bus 728. The processor 704 is also coupled to non-

transitory processor-readable storage media, such as a storage device 708 that stores processor-executable instructions 712 and data 710 through the system bus 728 to an I/O bus 726 through a storage controller 718. The processor 704 is also coupled to one or more interfaces that can be used to connect the processor to other processing apparatuses as well as networks as described herein. The processor 704 is also coupled via the bus to player input devices 714, such as tactile devices including, but not limited to, keyboards, keypads, foot pads, touch screens, and/or trackballs; as well as non-contact devices such as audio input devices, motion sensors and motion capture devices that the processing apparatus can use to receive inputs from a player when the player interacts with the processing apparatus. The processor 704 is connected to these player input devices 714 through the system bus 728, to the I/O bus 726 and through the input controller 720. The processor 704 is also coupled via the bus to player output devices 716 such as (but not limited to) visual output devices, audio output devices, and/or tactile output devices that the processing apparatus uses to generate outputs perceivable by the player when the player interacts with the processing apparatus. In accordance with some embodiments, the processor is coupled to visual output devices such as (but not limited to) display screens, light panels, and/or lighted displays. In accordance with particular embodiments, the processor is coupled to audio output devices such as (but not limited to) speakers, and/or sound amplifiers. In accordance with many of these embodiments, the processor 704 is coupled to tactile output devices like vibrators, and/or manipulators. The processor 704 is connected to output devices from the system bus 728 to the I/O bus 726 and through the output controller 722. The processor 704 can also be connected to a communications interface 702 from the system bus 728 to the I/O bus 726 through a communications controller 724.

[0046] In accordance with various embodiments, a processor 704 can load instructions and data from the storage device into the memory 706. The processor 704 can also execute instructions that operate on the data to implement various aspects and features of the components of a coincident gambling hybrid game. The processor 704 can utilize various input and output devices in accordance with the instructions and the data in order to create and operate player interfaces for players or operators of a

coincident gambling hybrid game(such as but not limited to a casino that hosts the coincident gambling hybrid game).

[0047] Although the processing apparatus 700 is described herein as being constructed from a processor and instructions stored and executed by hardware components, the processing apparatus can be composed of only hardware components in accordance with other embodiments. In addition, although the storage device is described as being coupled to the processor through a bus, those skilled in the art of processing apparatuses will understand that the storage device can include removable media such as, but not limited to, a USB memory device, an optical CD ROM, magnetic media such as tape and disks. Also, the storage device can be accessed by processor 704 through one of the interfaces or over a network. Furthermore, any of the player input devices or player output devices can be coupled to the processor 704 via one of the interfaces or over a network. In addition, although a single processor 704 is described, those skilled in the art will understand that the processor 704 can be a controller or other computing device or a separate computer as well as be composed of multiple processors or computing devices.

Coincident Gambling Event and Game Event

[0048] In accordance with many embodiments of the invention, an action in an entertainment game may trigger a gambling event that has a wager result and an effect on one or more variables in the entertainment game. In a specific instance, a gambling event is triggered by an actionable element, and feedback from the result of the gambling game. An overview of a process for providing a gambling event triggered by an action in the entertainment game that has a wager result and affects one or more variables in an entertainment game in accordance with embodiments of the invention is illustrated in FIG. 8.

[0049] In FIG. 8, a player 805 enters an input directing a controllable element 810 to perform an action event 815. The action event 815 is provided to a function 820, f1, which determines the AE triggers a gambling event. The gambling event includes a wager 825 of Real World Credits (RWC or RC) 830. The RWE 840 is informed of the gambling event and may determine whether the player has sufficient RC for the wager

(835). If the player has sufficient funds for the wager, RWE 840 generates the outcome of the gambling event. The result of the gambling game is provided to a function 845, f2, which determines the effects of the result on one or more variables within the Entertainment Game Variable Set 860. Thus, the changes to the variables in the Entertainment Game Variable Set 860 are provided to the ESE 850. The ESE 850 uses the result 845 of gambling event outcome to change variables 861-865 of an entertainment game variable set 860. The variables are observable to various degrees by the player and affect his (or his CE or agent's) interaction with the game. The player then observes the game state as a result of the change of the variables and acts accordingly. Thus, a closed-loop is created for the process.

[0050] The following is an example of the process in an adventure game using the process described with reference to FIG. 8. A player 805 enters an input that causes the player's CE 810 to open a door (AE 815). The opening of the door (AE 815) is provided to f1 that determines that the opening of the door triggers a gambling event 820. The result of the gambling event is then provided to f2 that determines that the result of the gambling event in addition to affecting the ESE 850 also affects the CE's characteristics (e.g. health or dexterity) and/or the contents of the room (e.g. the number of monsters or the amount of treasure therein). This example is illustrative only and not all encompassing. There are many other structures described previously that may include EE, CEE, and other elements, the contents of which are incorporated by reference herein. The absence of these elements is not meant, in any way, to indicate that the concepts discussed in this disclosure are not compatible with these other hybrid game aspects.

[0051] In accordance with some embodiments of the invention, the AE triggers a RNG, which then feeds a process that dictates a gambling game result and at the same time triggers a process that affects one or more variables within the entertainment game. A process for providing the results of a gambling event determined by a random number generated using an RNG in accordance with embodiments of the invention is shown in FIG. 9. In the process shown in FIG. 9, a player 905 enters an input directing a character element 910 to perform an action event 915. The AE 915 is provided to a function, f1 920 that determines whether the AE triggers a gambling event. When f1

920 determines that the AE triggers a gambling event, f1 may determine the amount of a wager of Real World Credits (RWC or RC) 930 on a gambling proposition. The RWE 940 is informed of the gambling event and may determine whether the player has sufficient RC for the wager (935). The RWE 940 uses information about f1 920 and the gambling event to determine the proper pay table to determine the results of the gambling event. If the player has sufficient funds for the wager, RWE 940 uses RNG 941 to generate a random number that is used to determine the outcome of the gambling event. In some embodiments, both the outcome of the gambling event and the random outcome generated by the RNG of the gambling game are provided to function 945, f2. The f2 945 determines whether and/or how the random outcome and the outcome of the gambling event affects one or more variables within the entertainment game variable set. The f2 945 then provides any changes to the variable to the ESE 950. The ESE 950 uses the gambling event outcome to change variables 961-965 of an entertainment game variable set 960. The variables affect various aspects of the entertainment game and these affects are observed by the player and affect the player's (or the player's CE or agent's) interaction with the game. The player then observes the game state as a result of the change of the variables and acts accordingly.

[0052] For example, consider an adventure game, akin to Dungeons and Dragons, where a player must roll a 6-sided die in the context of the game to determine if her CE hits an opponent with his sword and inflicts one health point of damage (in this context rolling a 6-sided die can refer to utilizing a RNG within a RWE to randomly select between one of six possible outcomes). If the player rolls a one or a two, the attack is successful. Roll a 3, 4, 5 or 6 and the attack is unsuccessful. The act of rolling a die also commits the player to a 1 RC bet, which provides payouts according to the following rule (i.e. the pay table): {1,2: 2 RC} {3,4,5,6: 0 RC}

[0053] When the player 905 directs the CE 910 to attack an opponent with his sword, which requires the rolling of a 6-sided die (the AE 915), the AE 915 provided to f1 event 920 that determines the AE initiates a gambling event. f1 920 communicates the gambling event to the RWE 940. The RWE 940 causes the RNG 941 to execute, generating an integer between one and six inclusive to determine the results of the

gambling event. It also commits the specified amount of RC 930 to a wagering proposition and may or may not preclude RNG 941 operation if RC is not available in the player's account to cover the wager (935). In this example, the gambling event 920 is not parameterizing the RNG 941 or selecting between multiple RNGs as a function of the entertainment game because only a single AE (i.e. rolling of a 6-sided die to establish the results of a sword attack) is contemplated. In other aspects of the system, the function f1 of gambling event 920 may specify which RNG is to be used in addition to establishing the amount of RC committed to the gambling game.

[0054] The RNG 941 result or outcome is provided to f2 945, which interprets effects on entertainment game variables by the result. In this example, a result of {1, 2} will cause the health points of the opponent to be reduced while a result of {3, 4, 5 or 6} will not lead to a change in the opponent's health points. In both cases, a graphical representation of the player's "die roll" is displayed to the player, which the player experiences as the result of the die roll or random outcome she initiated (the AE 915).

[0055] The RNG result is also fed to the Pay Table 942, which establishes the amount of RC 937 to be paid to the player (either 0 or 2). This result affects the player's RC and is displayed to the player accordingly (937).

[0056] Success in the entertainment game does not necessarily correlate with a win in the gambling game. Using the above example, where a player must roll a 6-sided die in the context of the game to determine if her CE hits an opponent with his sword and inflicts one health point of damage. If the player rolls a one, two, or three, the attack is successful. Roll a 4, 5 or 6 and the attack is unsuccessful. The act of rolling a die also commits the player to a 1 RC bet, which provides payouts according to the following rule (i.e. the pay table): {1,2: 2 RC} {3,4,5,6: 0 RC}. In this case, a roll of the "three" completes the attack in the adventure game, but does not result in a RC win.

[0057] In accordance with some embodiments of the invention, more than one dice roll is included as part of a sequence within game play of the coincident gambling hybrid game. For example, in an adventure game, a player may roll a 6-sided die to establish whether or not a sword attack hits an opponent, and then a 20-sided die may be rolled to establish the amount of damage inflicted by the sword. In these instances, multiple

serial die rolls (i.e. multiple AEs) are required as part of a CE action. This would constitute two cycles through the f1 loop in the processes shown in FIGS. 8 and 9 with f1 dictating a different RNG and possibly a different pay table, as well as the amount of RC contributed to the gambling game in each case. In accordance with these embodiments of the invention, the desired action includes multiple AEs that may involve a series of independent gambling events in that the RNG and pay tables are not compounded or combined as the coincident gambling hybrid game progresses. Alternatively, in other embodiments in accordance with this invention. The gambling events may be related and the pay tables may be compounded or combined based upon the results of the gambling events. As such, gambling games can be initiated in a number of ways, all foreseen as embodiments of the invention. A process for providing a series of gambling events resulting from an AE of a CE in accordance with embodiments of this is shown in FIG. 10.

[0058] In the process shown in FIG. 10, a player 1005 enters an input directing a character element 1010 to perform an action event 1015. The AE 1015 is provided to a function, f1 1020 that determines whether the AE triggers a gambling event. As illustrated in FIG. 10, f11020 takes as an additional parameter of a previous RNG result from prior RNG events within the RWE 1040 to determine the gambling event initiated. The RNG results are stored in a database 1022 within the RWE 140 and/or the GWE and is accessible by f1 1020. The database 1022 may also store other data as part of the RNG records including, for example, but not limited to, the time stamp of the RNG results, flags related to the state of entertainment game play variables at the time the RNG was initiated, etc. The logic represented in Table 1 is generically contained within f1 1020 in the GWE in accordance with embodiments of the invention. Table 1 is illustrative but not comprehensive in that the chain of events subsumed in this system can encompass many more than two successive random events. All of these events may be independent, dependent, or a combination thereof. The random events can also relate only to entertainment game variables, only to RC, or both simultaneously

Scenario	Step 1	Step 2	Example 1	Example 2

<p>1</p>	<p>First die roll or random outcome leads to initiation of gambling game, commitment of RC, payment of RC</p>	<p>Second die roll or random outcome leads to initiation of gambling game, commitment of RC, payment of RC independent of first roll.</p>	<p>In an adventure game, an attack with the sword requires a die roll. A second attack requires a new, independent die roll. Each roll initiates a gambling game.</p>	<p>In a football game, a play by the offense requires an RNG result to see if the pass is successful. A subsequent play requires a new, independent RNG result. Each play initiates a gambling game.</p>
<p>2</p>	<p>First die roll or random outcome leads to initiation of gambling game, commitment of RC, payment of RC</p>	<p>Second die leads to initiation of gambling game, which takes into account first and second die roll or random outcome results. Second die roll or random outcome leads to commitment of RC, payment of RC</p>	<p>In an adventure game, a player encounters a chest. The first die roll or random outcome determines the "energy cost" of opening the chest, initiating a gambling game. The second die roll or random outcome determines the contents of the chest, with the second gambling game using the RNG results from both die rolls.</p>	<p>In a football game, the player directs the quarterback to throw the ball. The first RNG result determines whether the ball is caught by the receiver, initiating a gambling game. The second RNG result determines how many yards are gained during the play, with the second gambling game using the RNG results from both events.</p>
<p>3</p>	<p>First die roll or random outcome leads to initiation of gambling game, commitment of RC, payment of RC</p>	<p>Second die roll or random outcome initiates gambling game (i.e. RNG + pay tables) but does not affect entertainment game variables.</p>	<p>In an adventure game, an attack with the sword requires a die roll. The first die roll or random outcome determines the entertainment game results. A second die roll or</p>	<p>In a game of battleship, firing a torpedo requires an RNG result. Based on the RNG, the player has either hit or missed the opposing force. A second die roll or random</p>

			random outcome initiates another gambling game, but does not influence the outcome of the entertainment game attack. Thus there are two gambling events and one entertainment game event.	outcome initiates another gambling event without committing the player to a move. There are two gambling events, increasing the rate of wagering, but not destabilizing the entertainment game.
4	First die roll or random outcome leads to initiation of gambling game, commitment of RC, payment of RC	Second die roll or random outcome does not initiate gambling game (i.e. RNG+pay tables), but only affects entertainment game variables via RNG	In an adventure game, an attack with the sword requires a die roll. A second roll is required to determine the amount of damage dealt by the first attack. Only the first die roll or random outcome initiates a gambling game.	In a tank battle game, an attack with a gun turret requires an RNG result. A second RNG result is required to determine how much of the tank crew's stamina is used during the attack. Only the first RNG result is factored into the gambling game.
5	First die roll or random outcome does not independently initiate a gambling game and does affect entertainment game variables.	Second die roll or random outcome leads to initiation of gambling game, commitment of RC, payment of RC independent of first roll.	In an adventure game, a player encounters a treasure chest. The first die roll or random outcome determines whether a player successfully opens the chest. This changes the entertainment game variables via RNG but does not initiate a gambling game.	In a football game, an offensive play requires an RNG result. This changes the entertainment game variables by reducing the number of downs available, changing the yards gained, adding points to the score, switching control of the ball, or a

			<p>If the first roll is successful, the second die roll or random outcome determines the contents of the chest. The gambling game initiated by the second die roll or random outcome exists independently from the contents of the chest.</p>	<p>wide variety of possible outcomes. The second RNG result initiates a gambling game and parameterizes the results of the first event. For instance, if the pass was successful from the first RNG result, the second RNG result would determine how many yards were gained.</p>
6	<p>First die roll or random outcome does not independently initiate a gambling game</p>	<p>Second die roll or random outcome leads to initiation of gambling game, which takes into account first and second die roll or random outcome results. Second die roll or random outcome leads to commitment of RC, payment of RC</p>	<p>In an adventure game, a player encounters a treasure chest. The first die roll or random outcome determines the contents of the chest. This changes the entertainment game variables via RNG but does not initiate a gambling game. The second die roll or random outcome determines whether a player successfully opens the chest. The gambling</p>	<p>In a football game, an offensive play requires an RNG result. This changes the entertainment game variables by reducing the number of downs available targets, changing the yards gained, adding points to the score, switching control of the ball, or a wide variety of possible outcomes. The second RNG result parameterizes the results of the</p>

			<p>game initiated by the second die roll or random outcome takes into account both rolls; that is, the contents of the chest and the success in opening the chest are independent from each other in the entertainment game, but both RNG results influence the single gambling game.</p>	<p>first event. For instance, if the pass was successful from the first RNG result, the second RNG result would determine how many yards were gained. The gambling game is initiated by the second event, but takes into account both RNG results.</p>
--	--	--	---	--

Table 1

[0059] When f1 1020 determines that the AE triggers a gambling event, f1 1020 may determine the amount of a wager of Real World Credits (RWC or RC) 1030 on a gambling proposition. The RWE 104040 is informed of the gambling event and may determine whether the player has sufficient RC for the wager (1035). The RWE 1040 uses information about f1 1020 and the gambling event to determine the proper pay table to determine the results of the gambling event. If the player has sufficient funds for the wager, RWE 1040 uses RNG 1041 to generate a random number that is used to determine the outcome of the gambling event. The outcome of the gambling game is provided to function 1045, f2. The f2 1045 determines whether and/or how the outcome of the gambling game affects one or more variables within the Entertainment Game Variable Set. The f2 1045 then provides any changes to the variable to the ESE 1050. The ESE 1050 uses the gambling event outcome to change variables 1061-1065 of an entertainment game variable set 1060. The variables are various degrees observed by the player and affecting his (or his CE or agent's) interaction with the game. The player then observes the game state as a result of the change of the variables and acts accordingly. As illustrated in the above diagram, f1 takes as an additional argument the RNG result from prior RNG events within the RWE.

In addition, the RWE 1040 provides the RNG results to database 1022. Database 1022 then stores the RNG results for future use by f1 1020. The f1 1020 ensures that subsequent dice rolls can be independent or dependent events with respect to prior dice rolls. Note also that “dice rolls” can be replaced by any random event within the coincident gambling hybrid game in the entertainment game context. For example, “a spin of a reel” could be the mechanism, or “the drawing of a card”, “drawing straws” or “playing a round of Russian Roulette”.

[0060] The ability of f1 1020 to reference prior RNG events also means that subsequent gambling events can be constructed as bonus rounds or special events (which may or may not include the commitment and/or payout of RC), for which players are made eligible as a result of prior RNG results. For example, in an adventure game, a player seeks to cast a spell. To successfully cast this spell, a very low probability event, the player must roll a twenty sided die (which in this example requires the commitment of 100 RC) and hit an ‘8’. The player does this (the AE), and the RNG returns an 8. A substantial RC payment is made, the spell is successfully cast within the entertainment game (as reflected in the entertainment game variables), and as a result the player is approached – in the entertainment game context – by a powerful wizard who offers the player the opportunity to acquire a new spell, requiring the rolling of a 10-sided die and hitting a one, two or three. This opportunity may or may not require the commitment of RC. Alternately, the bonus proposition may be a straight RC-related opportunity (which may or may not require the commitment of RC).

[0061] While the aforementioned examples have focused on an adventure game, the system is not limited to a specific game type or genre. For example, in a first person shooter, a trigger pull for a given weapon type can be associated with the rolling of a certain die for ascertaining whether the target is hit, and/or a die can be associated with establishing the amount of damage inflicted on the target if hit. For example, a pistol may hit its target on a roll of 1 or 2 on a 6-sided die, and may inflict between 1 and 6 damage points (again a 6-sided die), while a high powered rifle may hit on a 1, 2, 3, or 4 on a D10, and cause between 1 and 20 damage points (i.e. a 20-sided die). The rolling of the first die (the “did CE hit the target die”) can be triggered by the pulling of a trigger (or pressing of a button, for example), and the second would be initiated as a function of

the result of the first. In this example, a gambling game (and RC commitment) could be a function of the first, second, or both die rolls, i.e. the output of both RNG events may be data considered by the pay table when ascertaining the amount of RC to be paid to the player, this being coordinated by the actions of the f1, which selects the RNG and pay table as a function of current and historical data.

Coincident gambling hybrid game Providing Coincident Gambling Events and Game Events

[0062] A system that provides a coincident gambling hybrid game including coincident gambling and game events in accordance with embodiments of the invention is shown in FIGS. 11-14. A timing diagram of the information passed between various components of the system to provide coincident gambling and game events is shown in FIG. 11. The process begins when the ESE receives an input (1105) of an action with respect to a CE in the entertainment game. Based upon the input action, the ESE determines an AE performed by the CE. The AE is then provided to the GWE (1110). With reference to the above description a function, f1, in the GWE then determines a gambling event that corresponds to the AE. A request (1115) for the gambling event is then provided by the GWE to the RWE. The RWE then determines the result of the gambling event (1120). The result of the gambling event is then provided by the RWE to GWE (1125). The GWE then uses a function, f2, to determine how the result of the gambling event affects the set of game variables (1130). Any required updates of the game variable in the set of game variables are then provided by the GWE to the ESE. The ESE updates the set of game variables according to the received updates (1140) and presents the updated game to the player (1145).

[0063] A process for receiving the input from the player and updating the coincident gambling hybrid game based on the results of a gambling event in accordance with embodiments of the invention is shown in FIG. 12. In process 1200, the ESE receives the input from the player (1205). An AE that is performed by the CE based upon the input is determined (1210). The determined AE is then provided to the GWE by the ESE (1215). The update information for the game variables based upon the results of

the gambling event is received from the GWE (1220) and the ESE updates the game accordingly (1225).

[0064] A process for determining a gambling event based upon an AE and how the results of the gambling event affect the variables of an entertainment game performed by a GWE in accordance with embodiments of the invention is shown in FIG. 13. In process 1300, the GWE receives an AE from the ESE (1305). The GWE then determines a gambling event that is to occur based on the AE (1310). The determination may be made by a function, f1, as described above with reference to FIGS. 8-10. Furthermore, as described above, the determination may also use a past gambling event and/or RNG results to make the determination of the gambling event. GWE also may determine an amount to wager on a gambling proposition of the gambling event. The GWE then requests the determined gambling event be performed by the RWE (1315). The request may include the amount of RWC wager on the proposition. The GWE then receives the results of the gambling event from the RWC (1320). The results provided to the GWE may also include RNG results and other information. The GWE may store the results and/or other information received in a database for use in determination of future gambling events. The results of the gambling events are used by the GWE to determine updates of the game variables (1325). The updates are transmitted by the GWE to the ESE (1330).

[0065] A process performed by the RWE to determine the results of the gambling events and provide the results to the GWE in accordance with embodiments of the invention is shown in FIG. 14. In process 1400, the RWE receives a request for a gambling event from the GWE (1405). The request may include amount wagered, an indication of a proper RNG to use, and an indication of the pay tables to use to resolve the wager. The RWE determines whether the player has sufficient RWC available to cover the wager (1410). If the client does not have sufficient RWC to cover the wager, the RWE performs a recovery operation (1415). The recovery operation may prevent the wager from occurring or may allow the player to supply the necessary funds to cover the wager. If the player has sufficient RWC, the RWE generates a random number result using the proper RNG (1420). The random number result is then used to determine the results of the gambling event and do all other appropriate operations for

updating the RWC available to the player (1425). The RWE may store the result and/or other information about the result, including the random number result, in a database for future use (1430). The RWE also provides the result of the gambling event to the GWE (1435).

[0066] Although certain specific features and aspects of a gaming system have been described herein, many additional modifications and variations would be apparent to those skilled in the art. For example, the features and aspects described herein may be implemented independently, cooperatively or alternatively without deviating from the spirit of the disclosure. It is therefore to be understood that gaming system may be practiced otherwise than as specifically described. Thus, the foregoing description of the gaming system should be considered in all respects as illustrative and not restrictive, the scope of the claims to be determined as supported by this disclosure and the claims' equivalents, rather than the foregoing description.

WHAT IS CLAIMED IS:

1. A coincident gambling hybrid game having coincident gambling events and game events provided on a computing device, comprising:
 - an entertainment engine constructed to execute an entertainment game including receiving an input, determining an action event in the entertainment game from the input; and
 - a game world engine constructed to manage the entertainment engine that receives the action event from the entertainment engine, and determines whether the action event is associated with a gambling event;
 - a real world engine constructed to receive a request to determine an outcome of the gambling event, determine a random outcome from a random number generator, determine the outcome of the gambling event using the random outcome from the random number generator and a payable, resolve a wager on the gambling event based on the outcome of the gambling event, manage real world credits of a player based on the wager, and provide the outcome of the gambling event to the game world engine;wherein the game world engine is further constructed to:
 - receive the random outcome from the random number generator from the real world engine,
 - determine a change in a set of game variables based on the random outcome from the random number generator, and
 - provide the change in the set of game variables to the entertainment engine;wherein the entertainment engine is configured to:
 - receive the change to the set of game variables from the game world engine; and
 - incorporate the change to the set of game variables into the entertainment game.

2. The coincident gambling hybrid game of claim 1 wherein the game world engine is constructed to determine the gambling event associated with the action event from the action event and a previous random outcome from the random number generator of the real world engine.

3. The coincident gambling hybrid game of claim 2 wherein the game world engine is constructed to store the random outcome from the random number generator of the gambling event received from the real world engine in a database for use in determining a gambling event associated with an action event.

4. The coincident gambling hybrid game of claim 2 wherein the real world engine is constructed to store the random outcome from the random number generator in a database accessible by the game world engine for use in determining a gambling event associated with an action event.

5. The coincident gambling hybrid game of claim 1 wherein the random number generator uses a pseudo number generation process to generate the random outcome.

6. The coincident gambling hybrid game of claim 1 wherein the real world engine selects one random number generator from a plurality of random number generators to generate the random number information based on the gambling event.

7. The coincident gambling hybrid game of claim 1 wherein the real world engine determines a pay table to use to resolve the wager of the gambling event based upon the gambling event.

8. A method for providing a coincident gambling hybrid game having coincident gambling and game events provided on a computing device, comprising:
determining an action event in an entertainment game based on a player input into the entertainment game;

determining a gambling event associated with the action;
generating a random outcome for the gambling event;
determining an outcome for the gambling event using the random outcome and a payable;
determining changes to a set of game variables based on the random outcome; and
incorporating the changes in the set of game variables into the entertainment game.

9. The method of claim 8 wherein the determining of the gambling event associated with an action event is based upon the action event and a result of a previous random outcome.
10. The method of claim 8 further comprising storing the random outcome in a database.
11. The method of claim 8 further comprising selecting one of a plurality of random number generators to use to generate the random outcome based upon the gambling event.
12. The method of claim 8 further comprising determining one of a plurality of paytables to use to determine the outcome of the gambling event based upon a type of the gambling event.
13. A machine readable medium containing processor instructions, where execution of the instructions by a processor causes the processor to perform a process for providing a coincident gambling hybrid game having coincident gambling events and game events, comprising:
 - determining an action event in an entertainment game based on a player input into the entertainment game;
 - determining a gambling event associated with the action;

generating a random outcome for the gambling event;
determining an outcome for the gambling event using the random outcome and a paytable;
determining changes to a set of game variables based on the random outcome; and
incorporating the changes in the set of game variables into the entertainment game.

14. The machine readable medium containing processor instructions of claim 13 wherein the determining of the gambling event associated with an action event in the method is based upon the action event and a result of a previous random outcome.

15. The machine readable medium containing processor instructions of claim 13 wherein the method further comprises selecting one of a plurality of random number generators in the real world engine to use to generate the random number information based upon the gambling event.

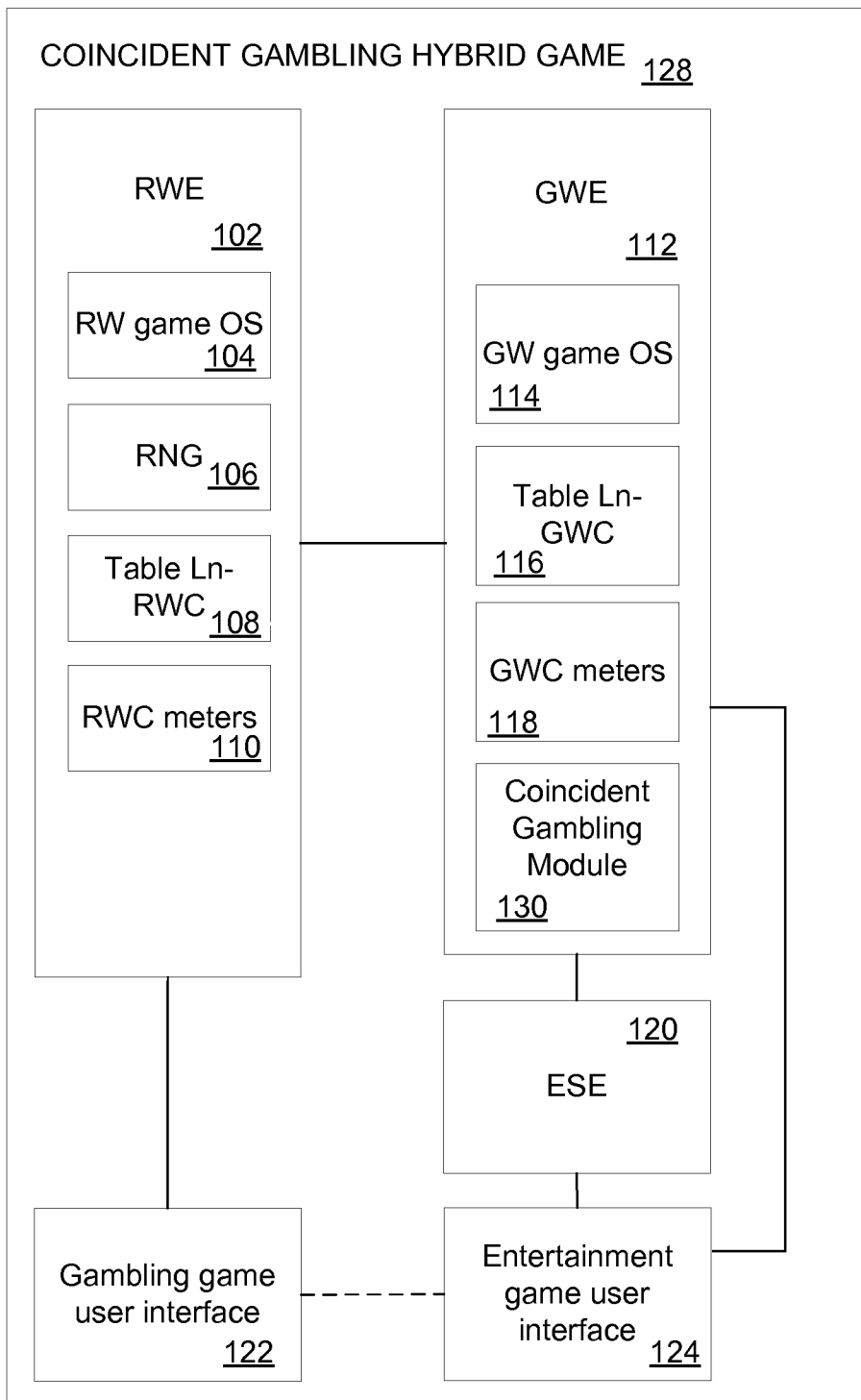

FIG. 1

2/14

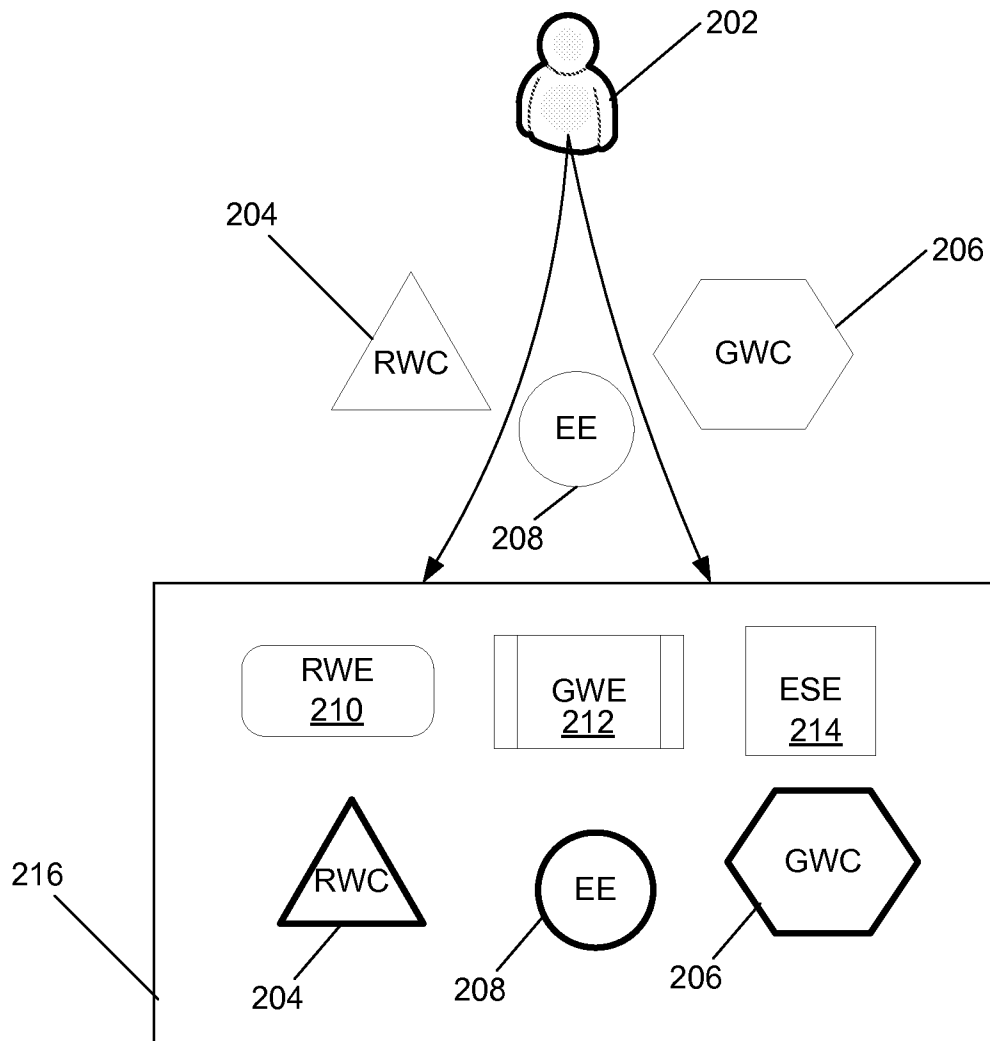

FIG. 2

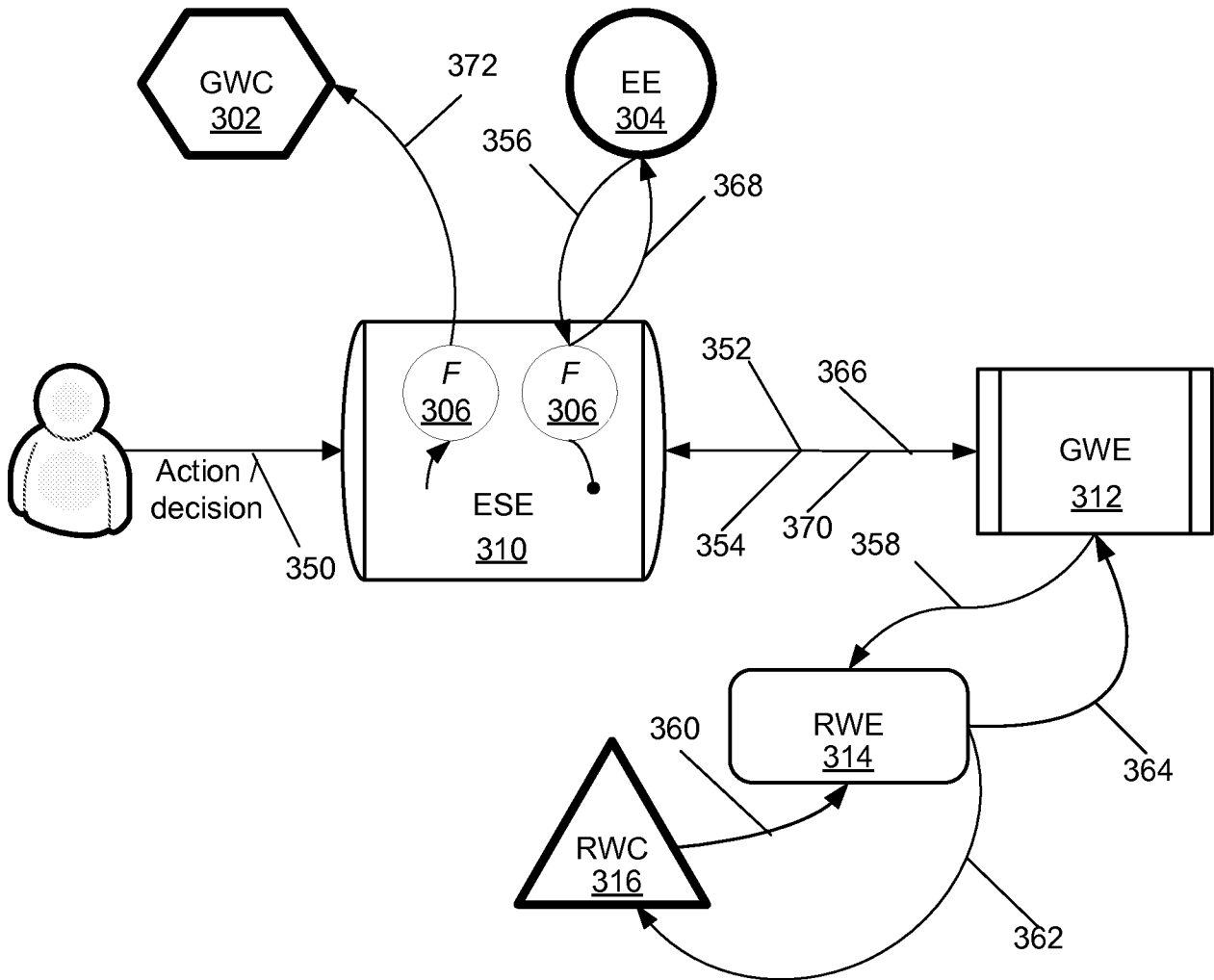

FIG. 3

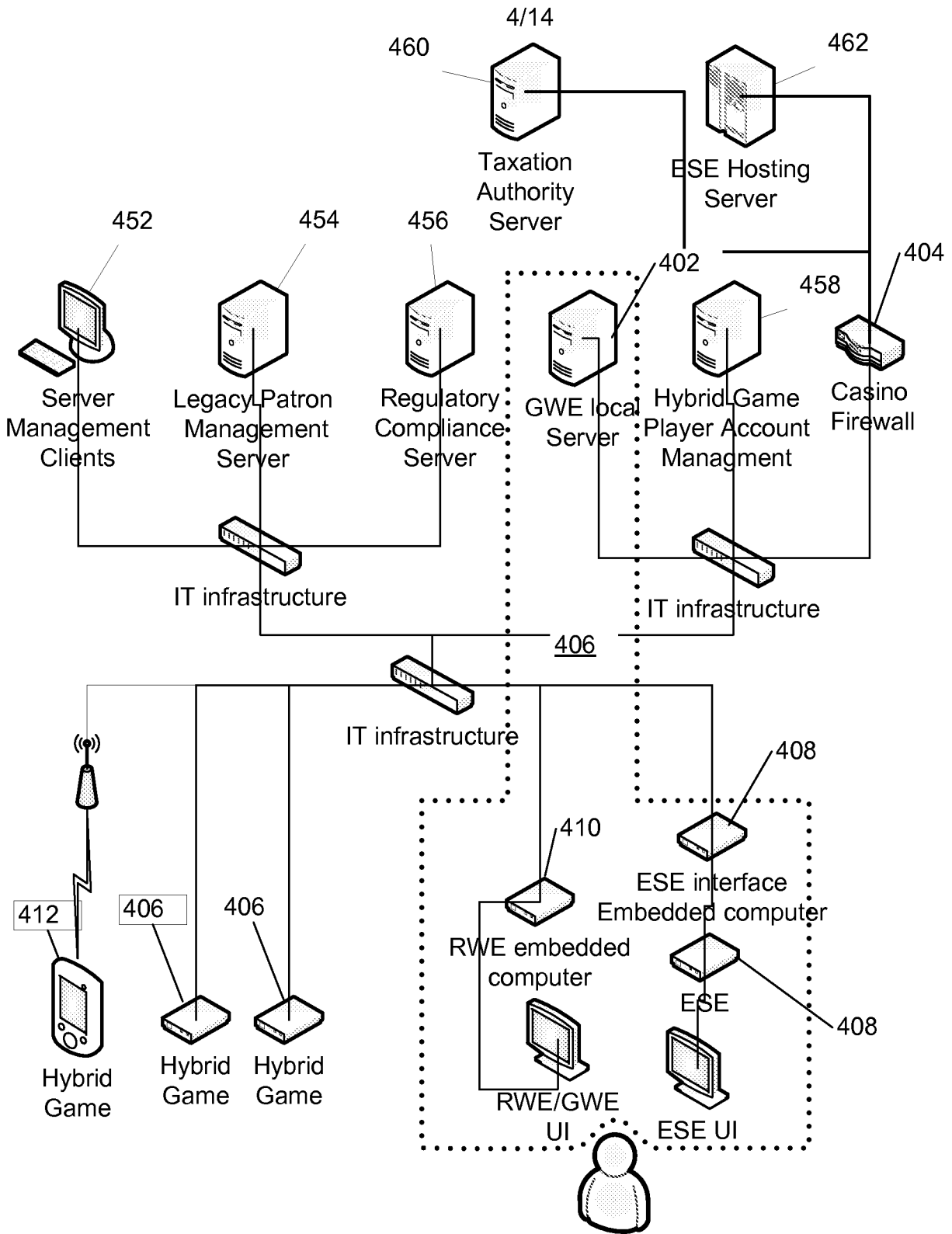

FIG. 4

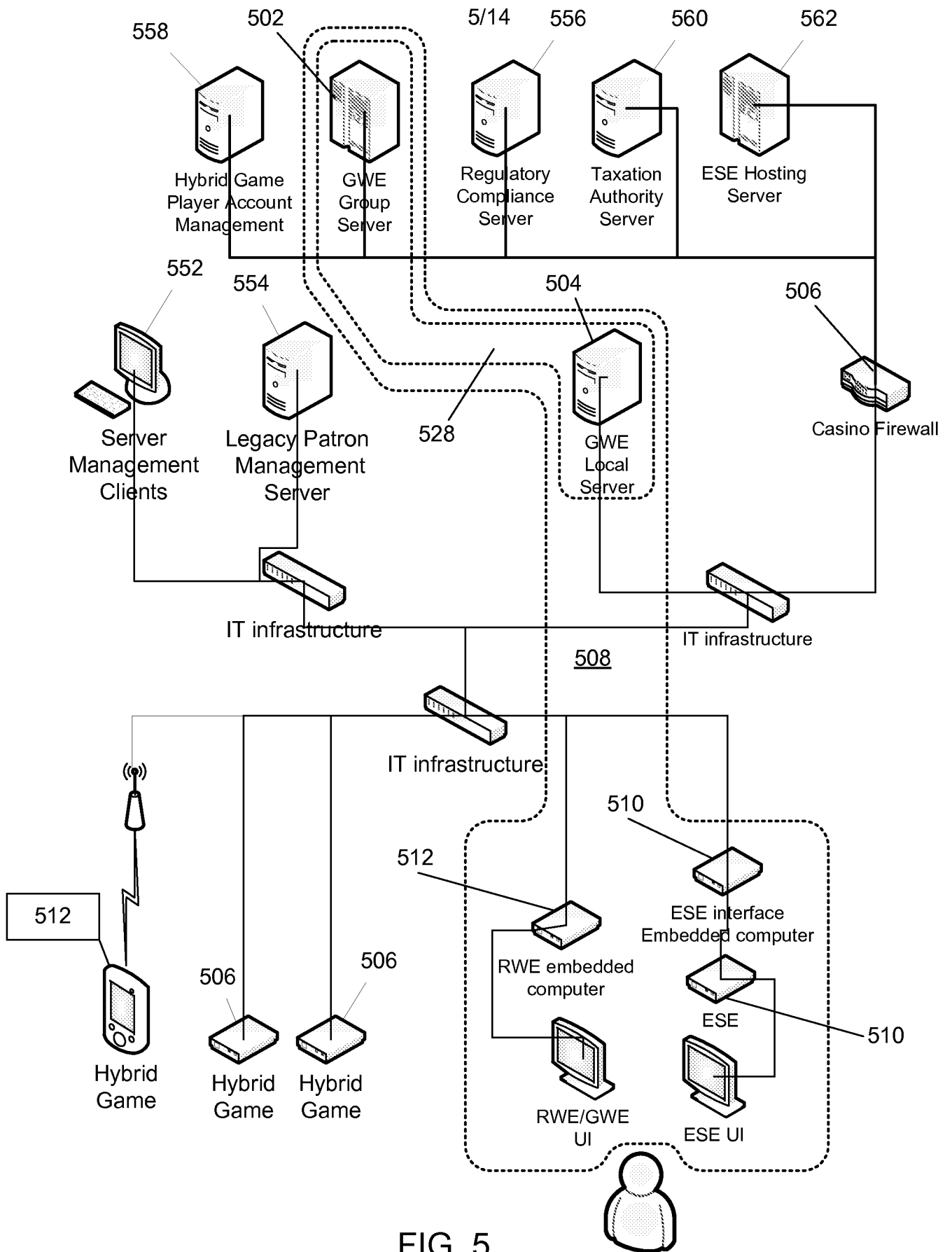

FIG. 5

6/14

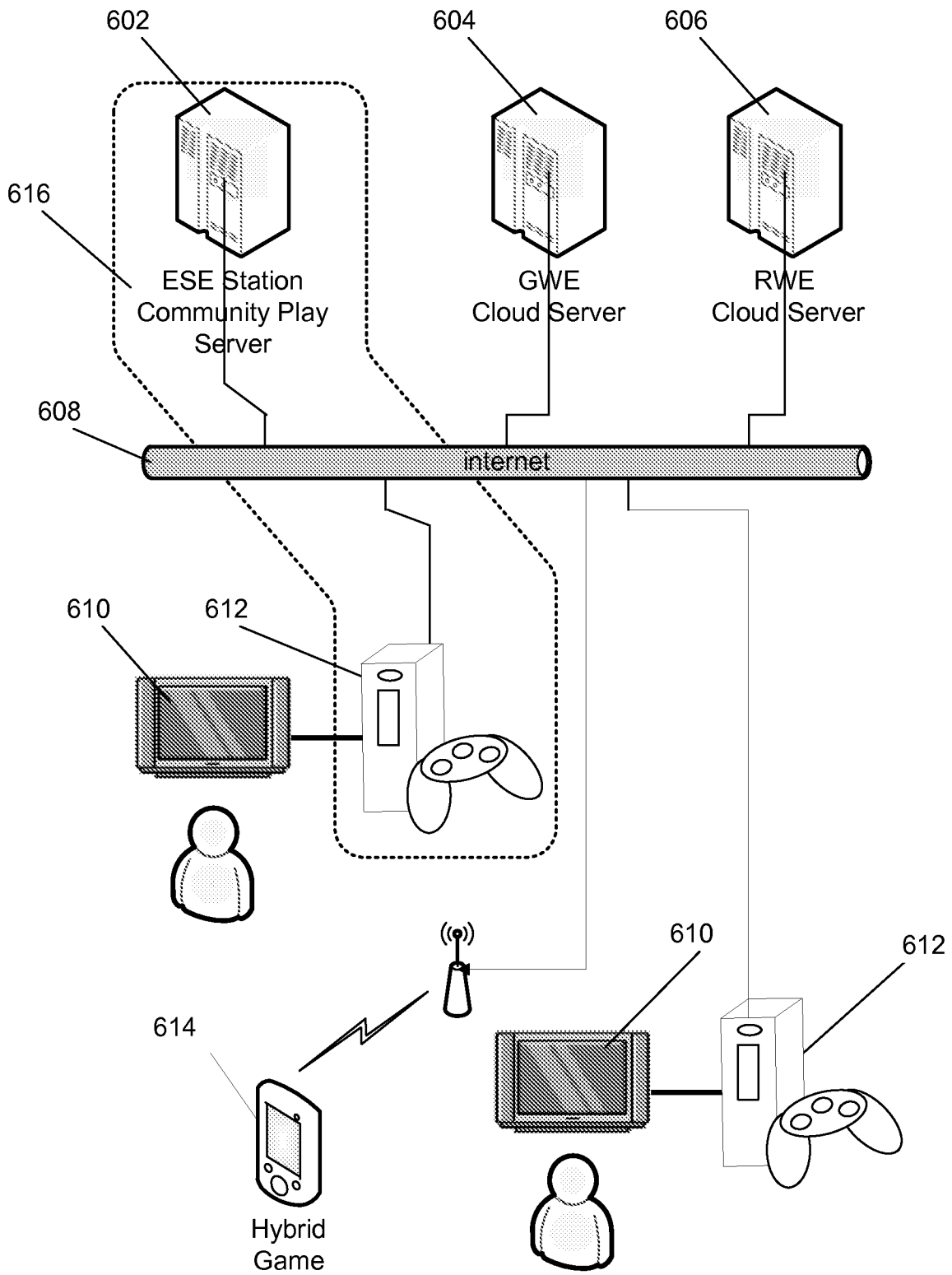

FIG. 6

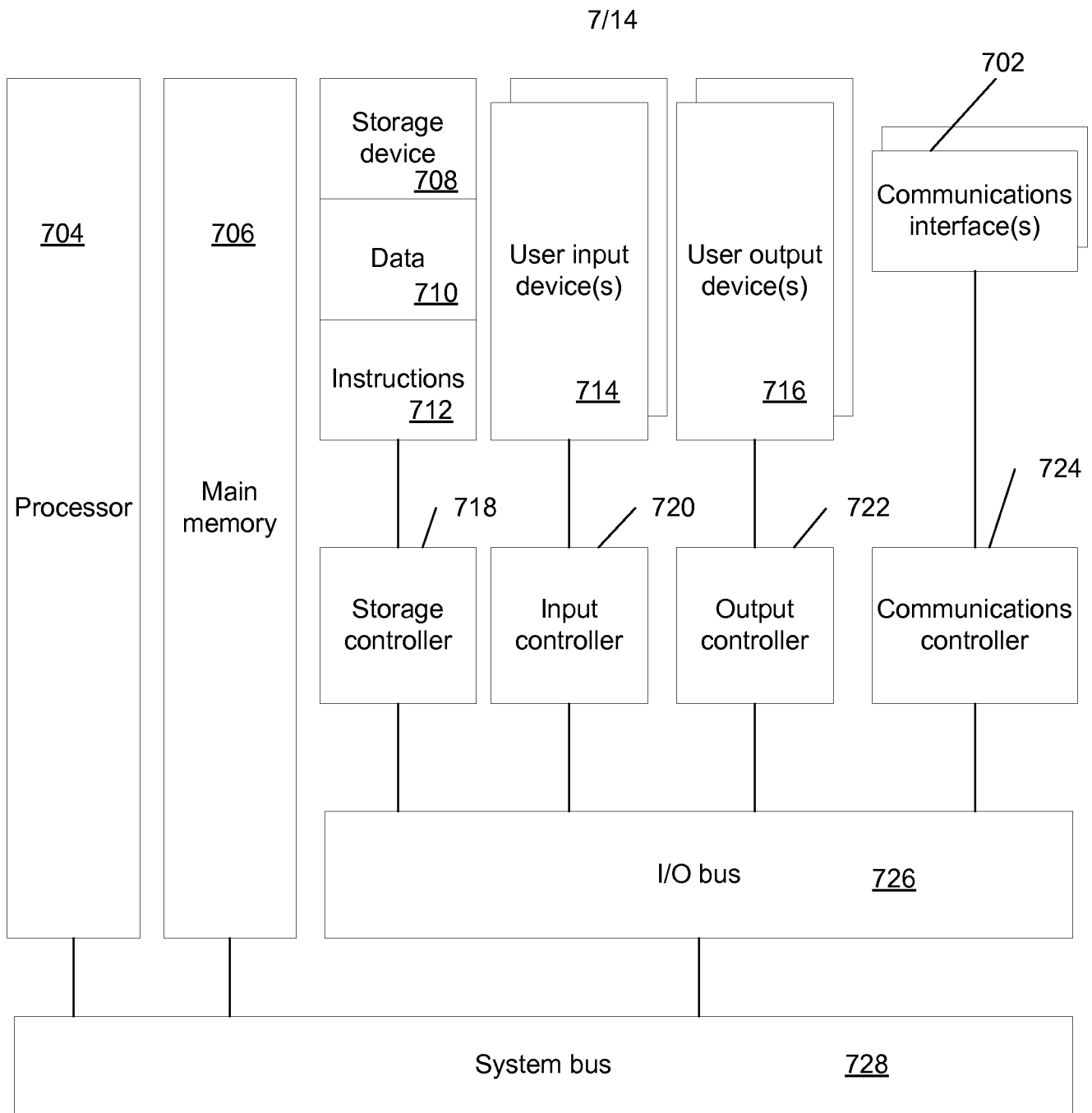

FIG. 7

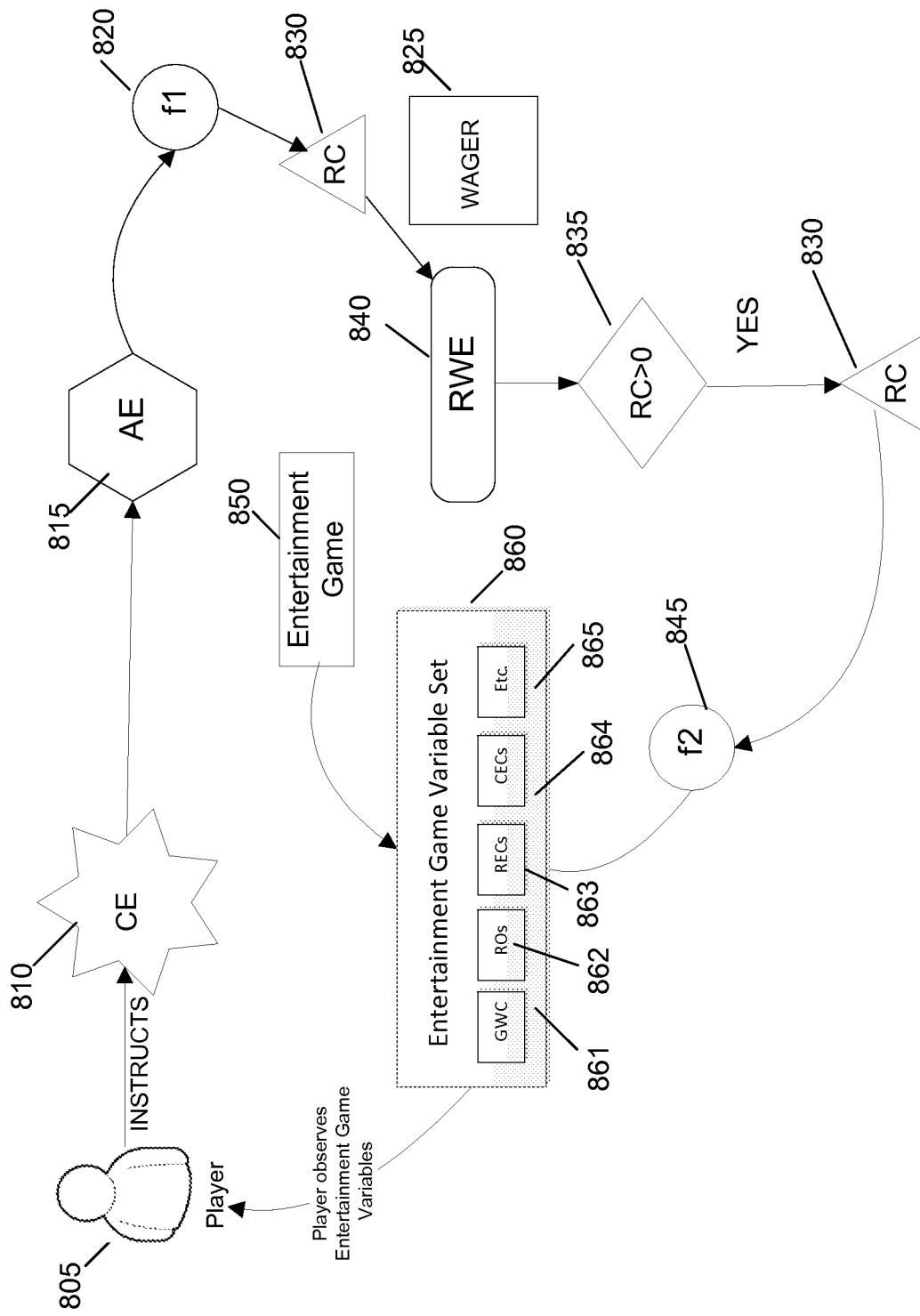

FIG. 8

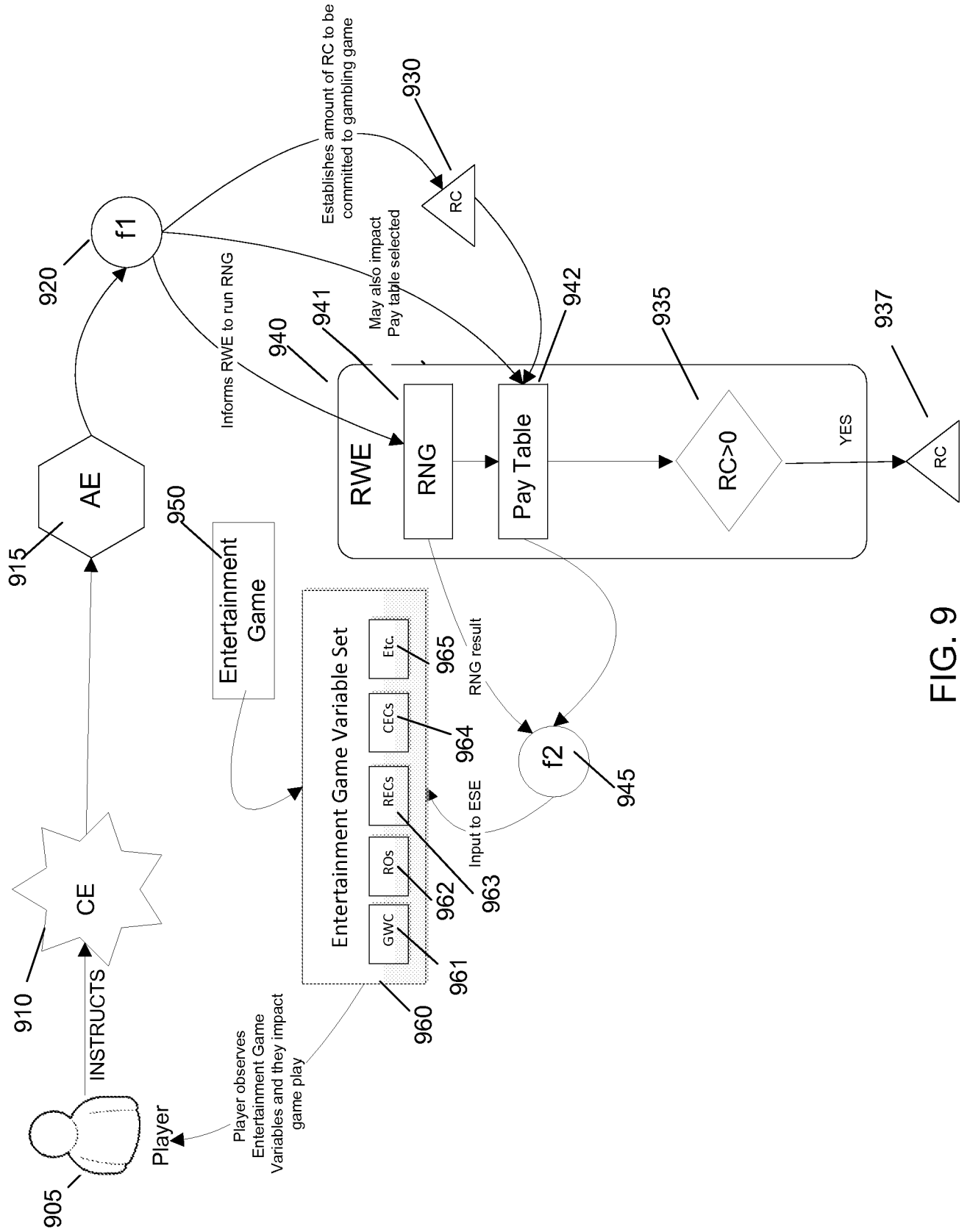

FIG. 9

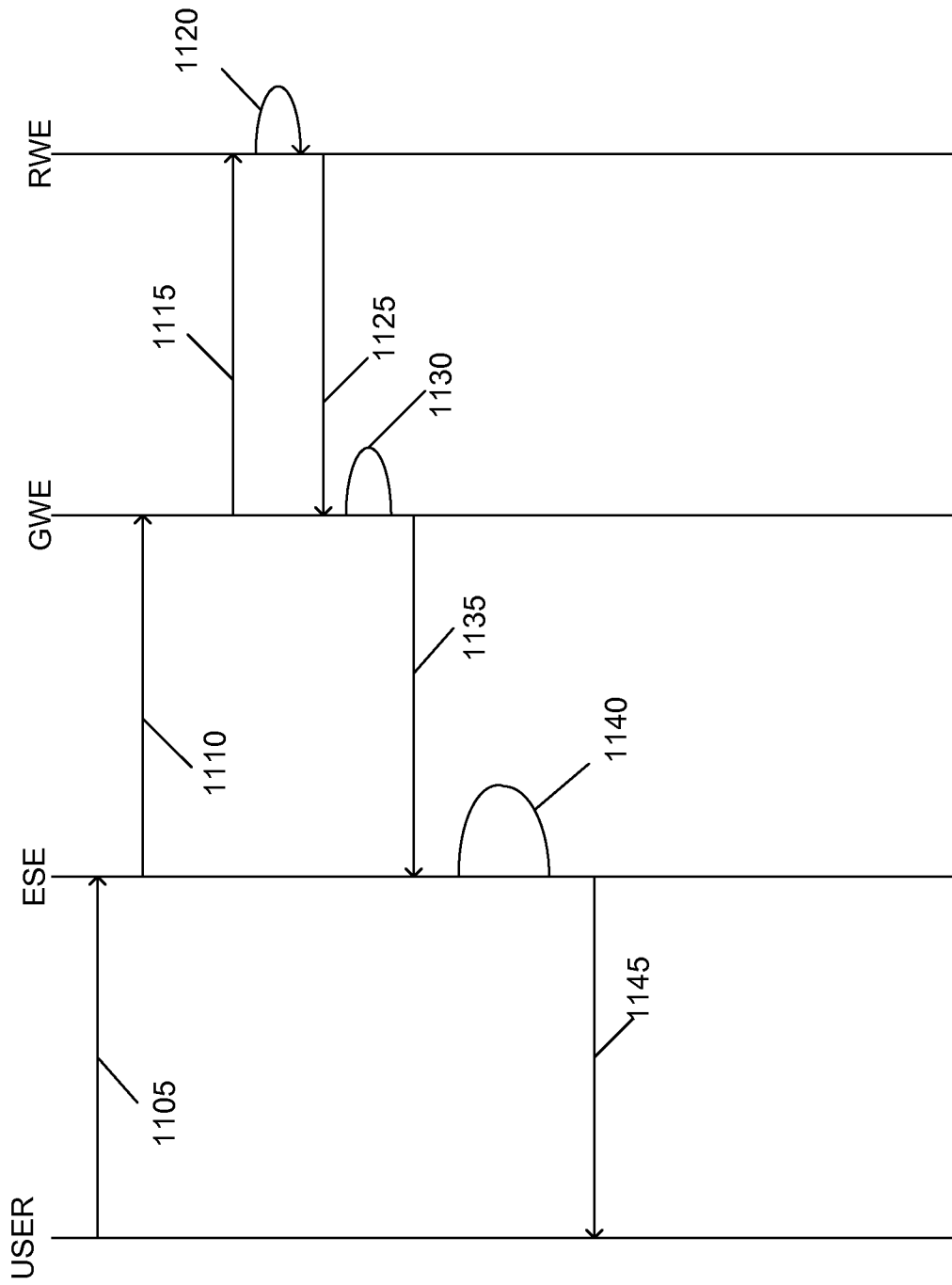

FIG. 11

12/14

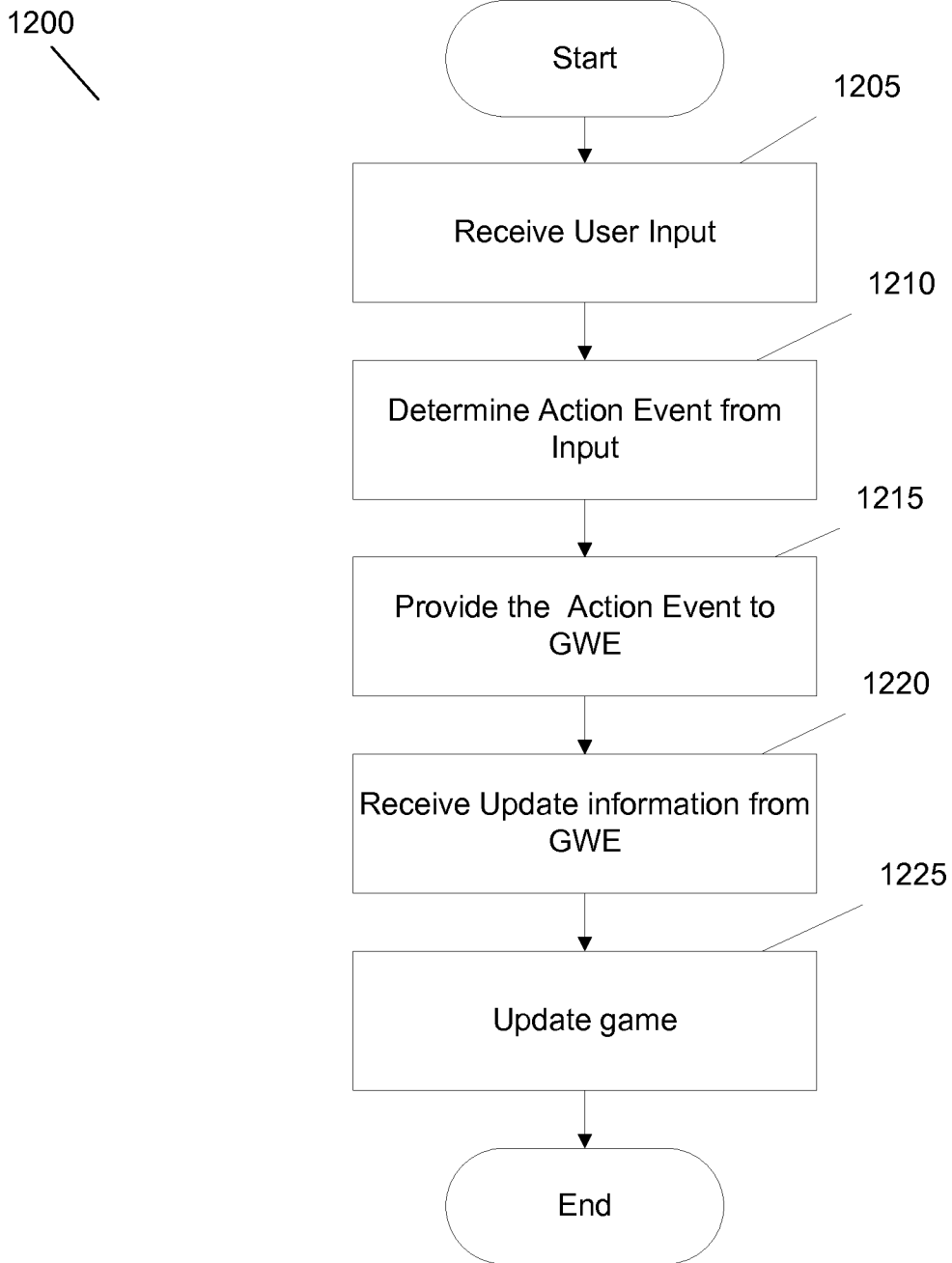

FIG. 12

13/14

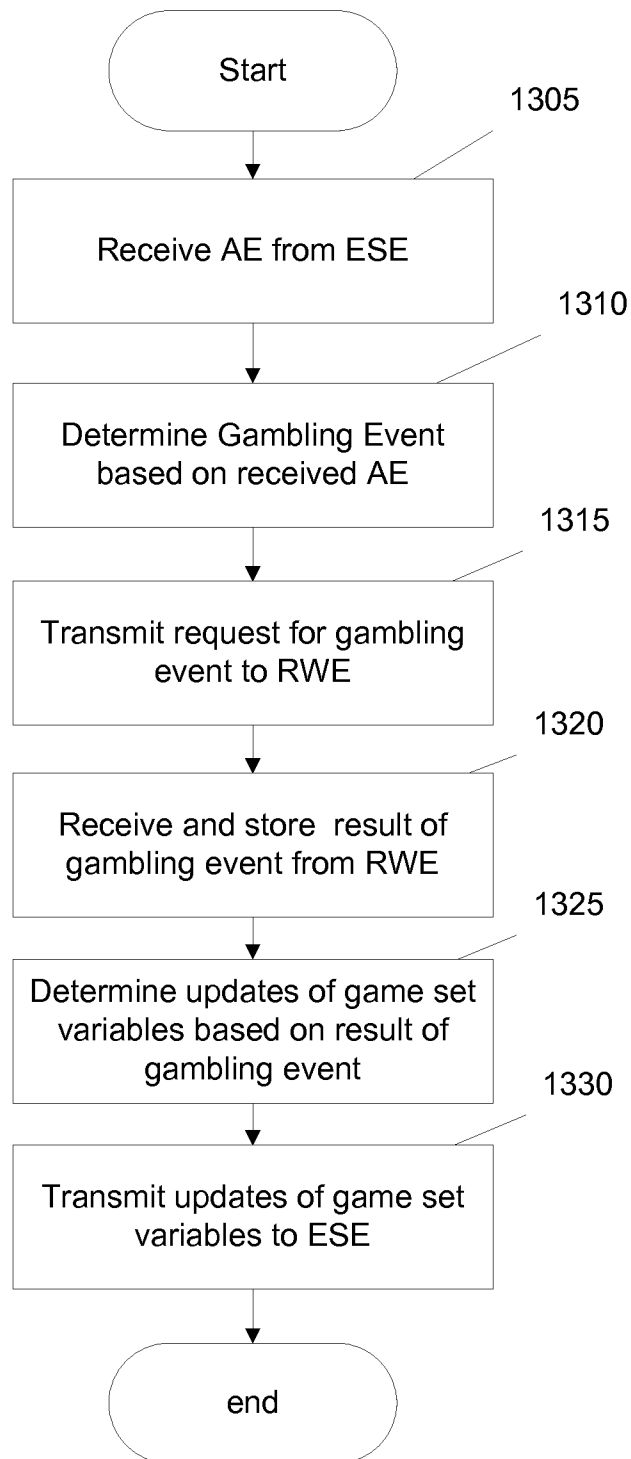

FIG. 13

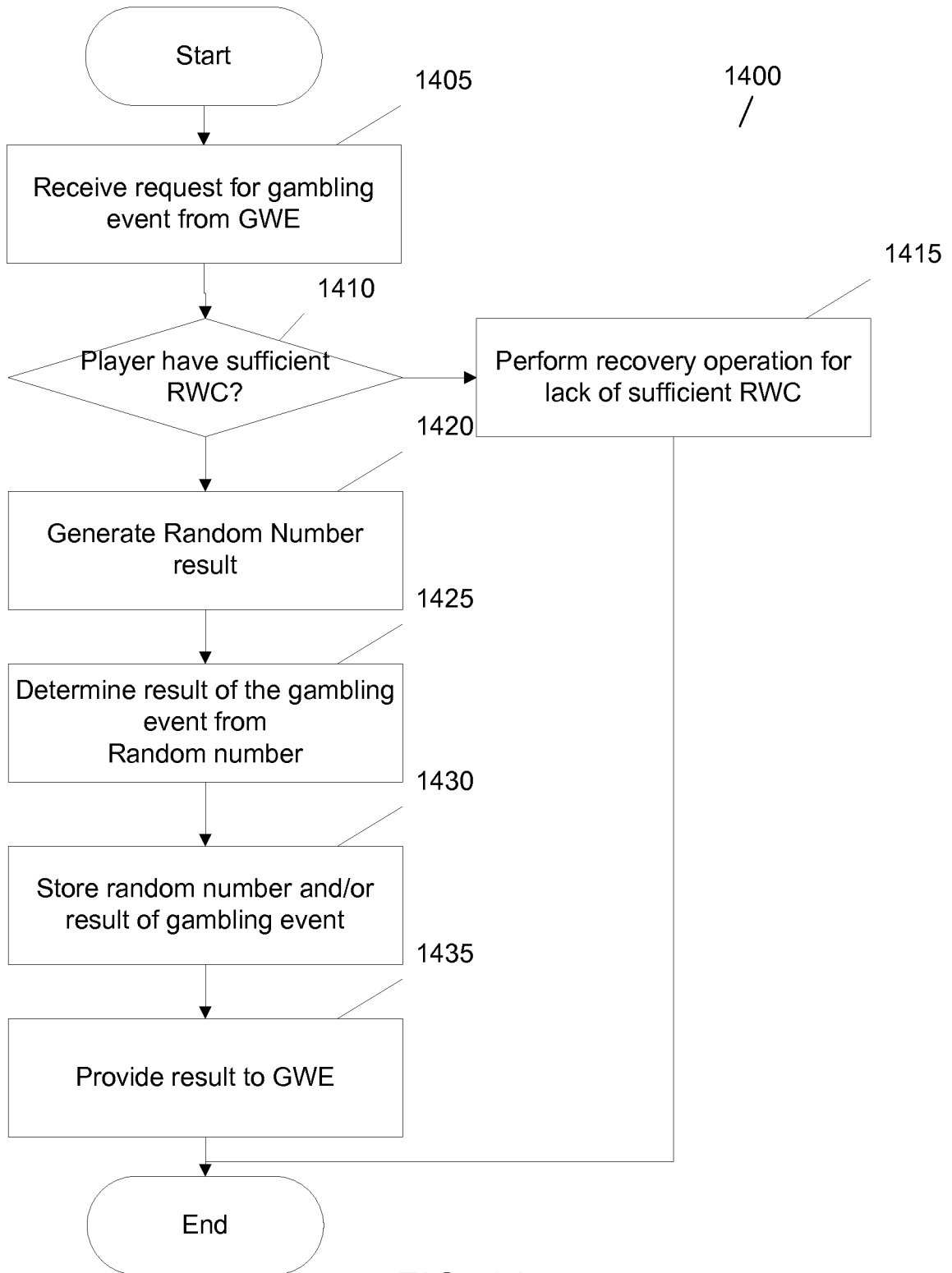

FIG. 14