



US00D400366S

United States Patent [19]
Bush

[11] **Patent Number:** **Des. 400,366**
[45] **Date of Patent:** ****Nov. 3, 1998**

[54] **COLLAPSIBLE CHAIR**

[76] Inventor: **Alfred Bush**, 26 Spice Hill,
Croton-on-Hudson, N.Y. 10520

[**] Term: **14 Years**

[21] Appl. No.: **68,982**

[22] Filed: **Apr. 24, 1997**

[51] **LOC (6) Cl.** **06-01**

[52] **U.S. Cl.** **D6/368; D6/374**

[58] **Field of Search** D6/334, 335, 368,
D6/370, 371, 373, 374, 500, 501, 502;
297/440.13

[56] **References Cited**

U.S. PATENT DOCUMENTS

D. 58,554 8/1921 Dodson D6/374

D. 58,555 8/1921 Dodson D6/348
D. 66,524 1/1925 Wurdack et al. D6/348
D. 78,926 7/1929 Gottlob D6/374 X
D. 251,641 4/1979 Chacon D6/371

Primary Examiner—Gary D. Watson

[57] **CLAIM**

The ornamental design for a collapsible chair, as shown and described.

DESCRIPTION

FIG. 1 is a front elevational view of the collapsible chair showing my new design;
FIG. 2 is a rear elevational view thereof;
FIG. 3 is a right side view thereof;
FIG. 4 is a left side view thereof;
FIG. 5 is a top plan view thereof; and,
FIG. 6 is a bottom plan view thereof.

1 Claim, 3 Drawing Sheets

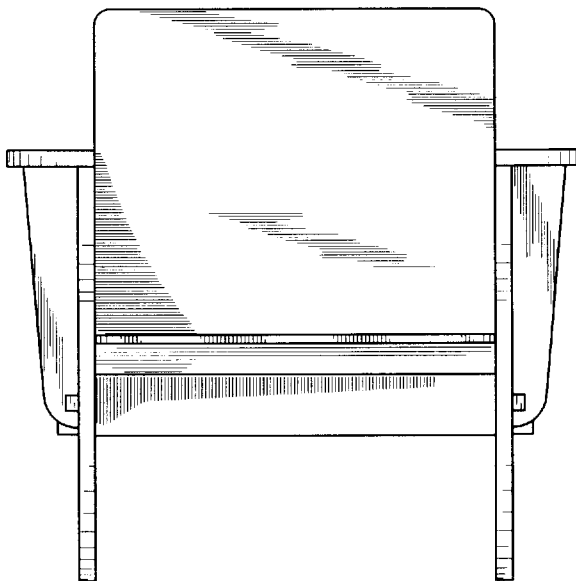

FIG. 1

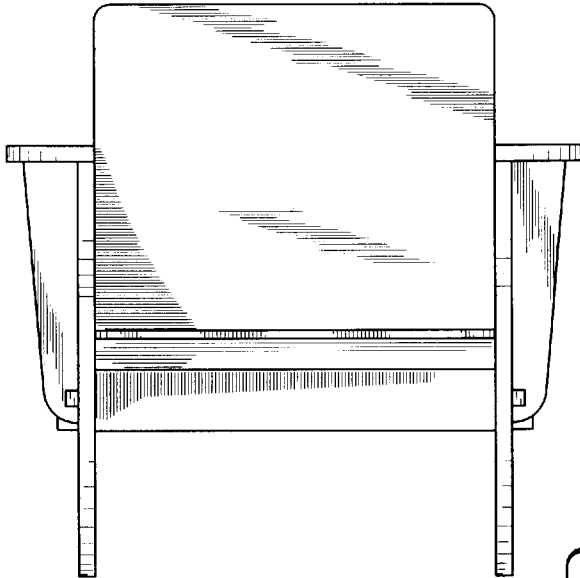

FIG. 2

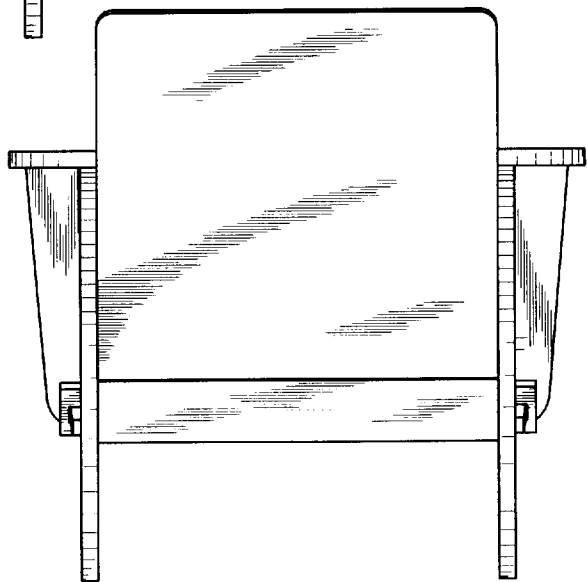

FIG. 3

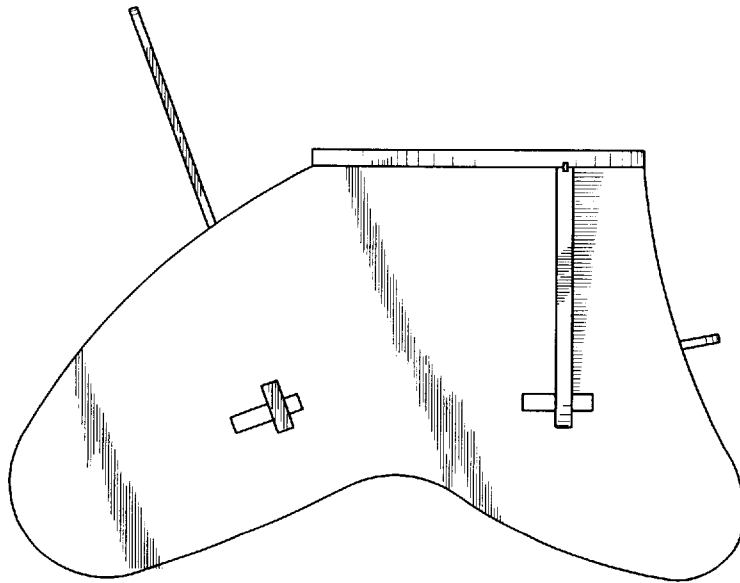

FIG. 4

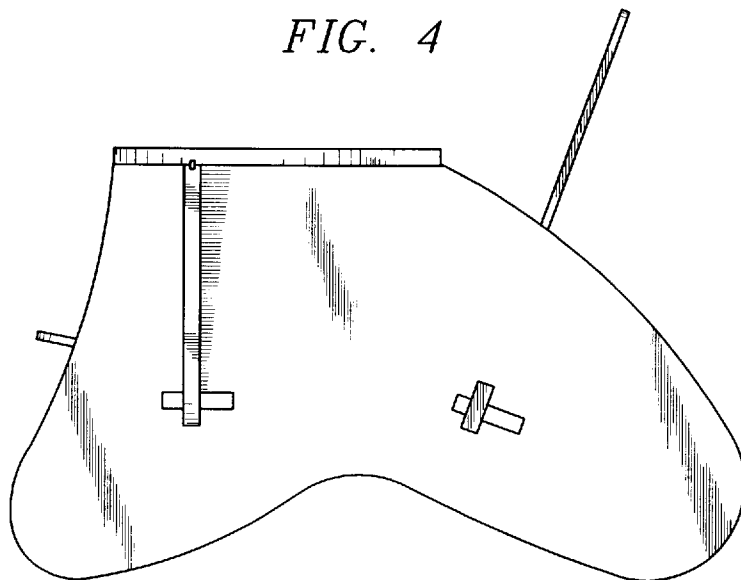

FIG. 5

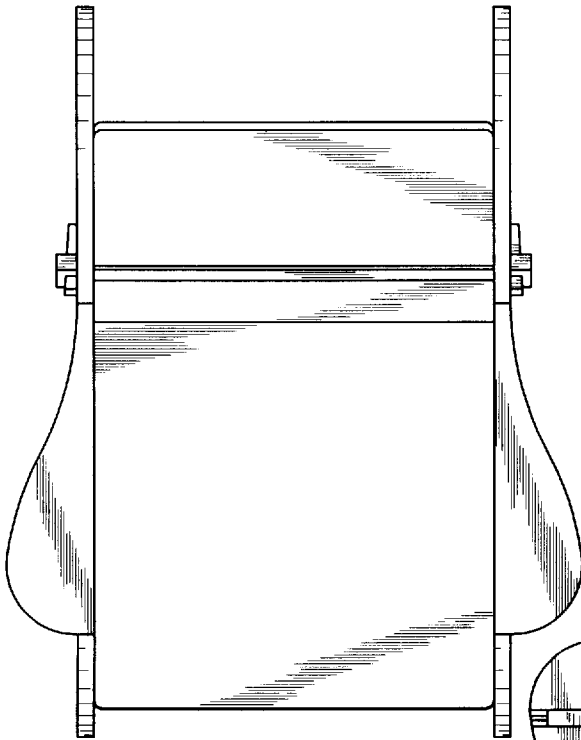

FIG. 6

