

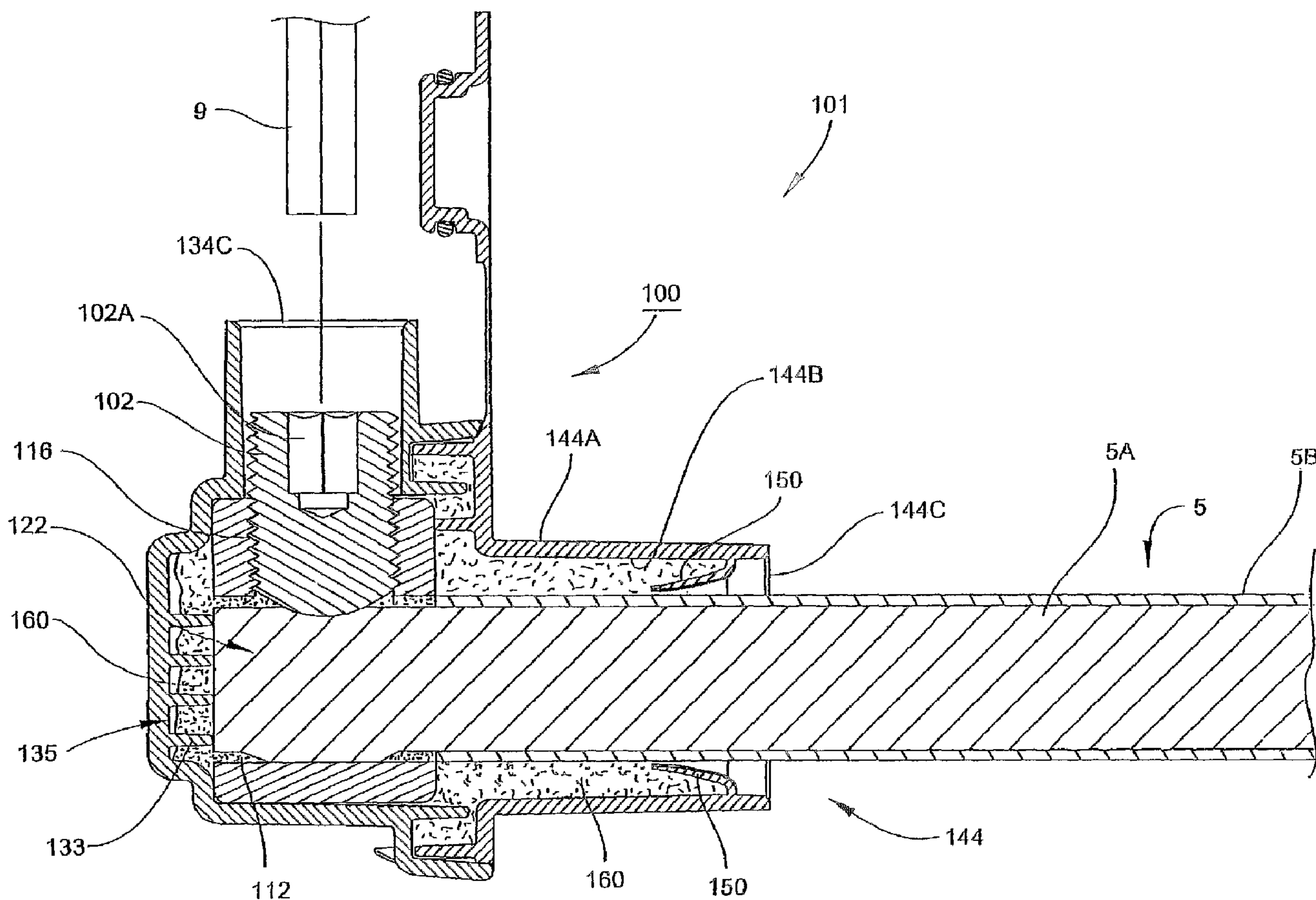

(86) Date de dépôt PCT/PCT Filing Date: 2003/12/01  
 (87) Date publication PCT/PCT Publication Date: 2004/09/02  
 (45) Date de délivrance/Issue Date: 2012/03/20  
 (85) Entrée phase nationale/National Entry: 2005/06/17  
 (86) N° demande PCT/PCT Application No.: US 2003/038594  
 (87) N° publication PCT/PCT Publication No.: 2004/075358  
 (30) Priorités/Priorities: 2002/12/20 (US10/324,817);  
 2003/11/25 (US10/722,351)

(51) Cl.Int./Int.Cl. *H01R 13/52* (2006.01),  
*H01R 9/24* (2006.01)  
 (72) Inventeurs/Inventors:  
 YAWORSKI, HARRY, GEORGE, US;  
 BLUE, KENTON, ARCHIBALD, US;  
 BUKOVNIK, RUDOLF, ROBERT, US  
 (73) Propriétaire/Owner:  
 TYCO ELECTRONICS CORPORATION, US  
 (74) Agent: FETHERSTONHAUGH & CO.

(54) Titre : CONNECTEURS ELECTRIQUES ET LEURS PROCEDES D'UTILISATION  
 (54) Title: ELECTRICAL CONNECTORS AND METHODS FOR USING THE SAME



(57) Abrégé/Abstract:

An electrical connector for use with a conductor includes a housing defining a port. The port includes an entrance opening, an exit opening, and a conductor passage extending between and communicating with the entrance and exit openings. The conductor

(57) **Abrégé(suite)/Abstract(continued):**

passage is adapted to receive the conductor therethrough. Sealant is disposed in the conductor passage. The sealant is adapted for insertion of the conductor therethrough such that the sealant provides a seal about the inserted conductor. A penetrable closure wall extends across the conductor passage.

(12) INTERNATIONAL APPLICATION PUBLISHED UNDER THE PATENT COOPERATION TREATY (PCT)

(19) World Intellectual Property  
Organization  
International Bureau



(43) International Publication Date  
2 September 2004 (02.09.2004)

PCT

(10) International Publication Number  
**WO 2004/075358 A1**

- (51) International Patent Classification<sup>7</sup>: **H01R 13/52**
- (21) International Application Number: PCT/US2003/038594
- (22) International Filing Date: 1 December 2003 (01.12.2003)
- (25) Filing Language: English
- (26) Publication Language: English
- (30) Priority Data:  
10/324,817 20 December 2002 (20.12.2002) US  
10/722,351 25 November 2003 (25.11.2003) US
- (71) Applicant (for all designated States except US): **TYCO ELECTRONICS CORPORATION** [US/US]; 2901 Fulling Mill Road, Middletown, PA 17057-3163 (US).
- (72) Inventors; and
- (75) Inventors/Applicants (for US only): **YAWORSKI, Harry, George** [US/US]; 207 Temple Gate Drive, Apex, NC 27502 (US). **BLUE, Kenton, Archibald** [US/US]; 4108 Stansted Drive, Fuquay-Varina, NC 27526 (US). **BUKOVNIK, Rudolf, Robert** [CA/US]; 100 Red Cedar Place, Chapel Hill, NC 27514 (US).
- (74) Agents: **TYCO ELECTRONICS CORPORATION** et al.; Marguerite E. Gerstner, David D. Beatty, M/S R20/2B, 307 Constitution Drive, Menlo Park, CA 94026-1164 (US).
- (81) Designated States (*national*): AE, AG, AL, AM, AT, AU, AZ, BA, BB, BG, BR, BW, BY, BZ, CA, CH, CN, CO, CR, CU, CZ, DE, DK, DM, DZ, EC, EE, EG, ES, FI, GB, GD, GE, GH, GM, HR, HU, ID, IL, IN, IS, JP, KE, KG, KP, KR, KZ, LC, LK, LR, LS, LT, LU, LV, MA, MD, MG, MK, MN, MW, MX, MZ, NI, NO, NZ, OM, PG, PH, PL, PT, RO, RU, SC, SD, SE, SG, SK, SL, SY, TJ, TM, TN, TR, TT, TZ, UA, UG, US, UZ, VC, VN, YU, ZA, ZM, ZW.
- (84) Designated States (*regional*): ARIPO patent (BW, GH, GM, KE, LS, MW, MZ, SD, SL, SZ, TZ, UG, ZM, ZW), Eurasian patent (AM, AZ, BY, KG, KZ, MD, RU, TJ, TM), European patent (AT, BE, BG, CH, CY, CZ, DE, DK, EE, ES, FI, FR, GB, GR, HU, IE, IT, LU, MC, NL, PT, RO, SE, SI, SK, TR), OAPI patent (BF, BJ, CF, CG, CI, CM, GA, GN, GQ, GW, ML, MR, NE, SN, TD, TG).
- Published:**  
— with international search report

[Continued on next page]

(54) Title: ELECTRICAL CONNECTORS AND METHODS FOR USING THE SAME

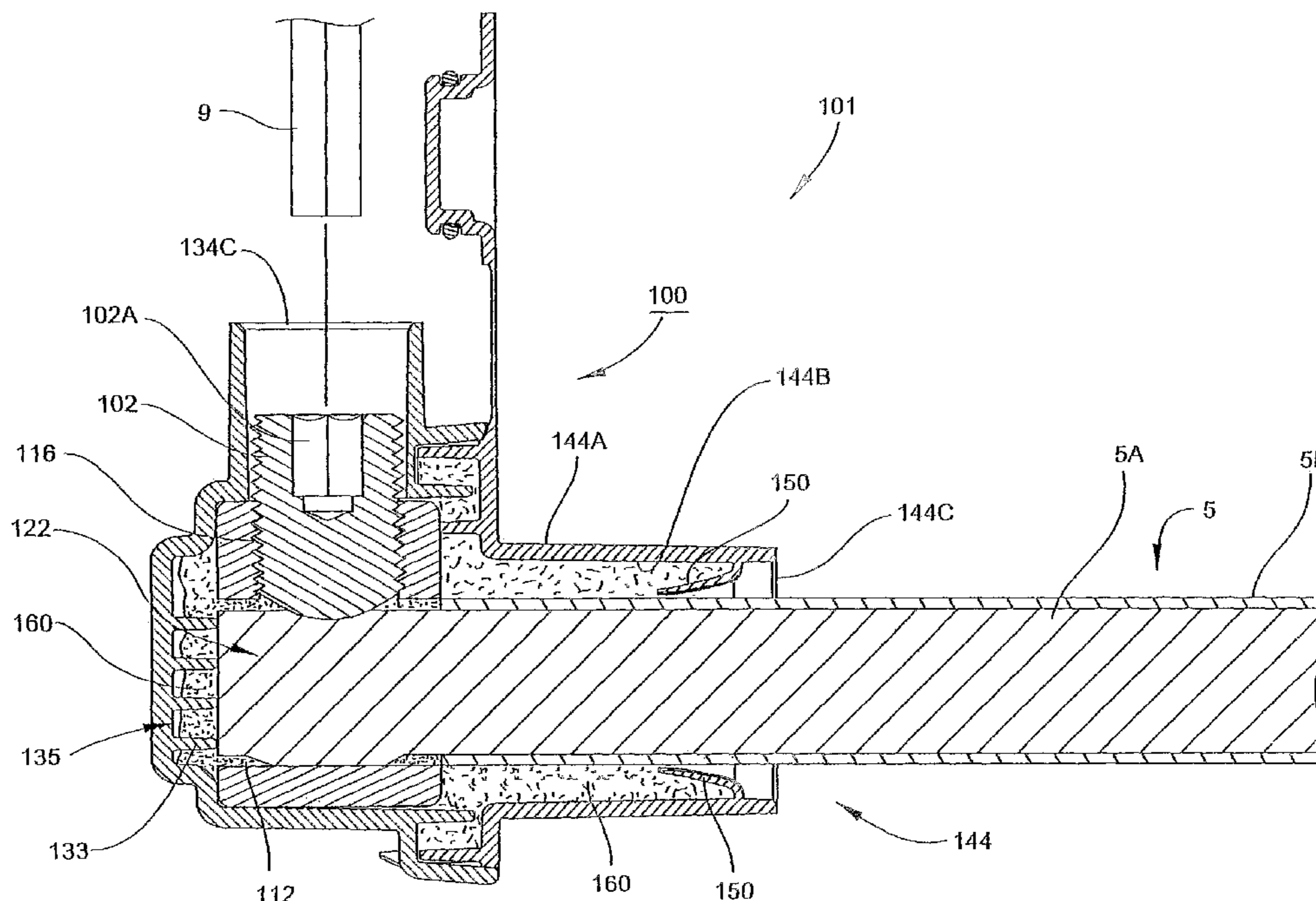

(57) Abstract: An electrical connector for use with a conductor includes a housing defining a port. The port includes an entrance opening, an exit opening, and a conductor passage extending between and communicating with the entrance and exit openings. The conductor passage is adapted to receive the conductor therethrough. Sealant is disposed in the conductor passage. The sealant is adapted for insertion of the conductor therethrough such that the sealant provides a seal about the inserted conductor. A penetrable closure wall extends across the conductor passage.

WO 2004/075358 A1

**WO 2004/075358 A1**



---

*For two-letter codes and other abbreviations, refer to the "Guidance Notes on Codes and Abbreviations" appearing at the beginning of each regular issue of the PCT Gazette.*

## **ELECTRICAL CONNECTORS AND METHODS FOR USING THE SAME**

### **Field of the Invention**

The present invention relates to electrical connectors and methods for using the same and, more particularly, to environmentally protected electrical connectors and methods for forming environmentally protected connections.

5

### **Background of the Invention**

Multi-tap or busbar connectors are commonly used to distribute electrical power, for example, to multiple residential or commercial structures from a common power supply feed. Busbar connectors typically include a conductor member formed of copper or aluminum housed in a polymeric cover. The conductor member includes a plurality of cable bores. The cover includes a plurality of ports, each adapted to receive a respective cable and to direct the cable into a respective one of the cable bores. A set screw is associated with each cable bore for securing the cables in the respective bores and, thereby, in electrical contact with the conductor member.

15

The busbar assemblies as described above can be used to electrically connect two or more cables. For example, a feed cable may be secured to the busbar connector through one of the ports and one or more branch or tap circuit cables may be connected to the busbar connector through the other ports, to distribute power from the feed cable. Busbar connectors of this type provide significant convenience in that cables can be added and removed from the connection as needed.

20

Power distribution connections as discussed above are typically housed in an above-ground cabinet or a below-grade box. The several cables are usually fed up through the ground and the connection (including the busbar connector) may remain unattached to the cabinet or box (i.e., floating within the cabinet). The connections may be subjected to moisture, and may even become submerged in water. If the conductor member and the conductors are left exposed, water and environmental contaminants may cause corrosion thereon. Moreover, the conductor member is often formed of aluminum, so that water may cause oxidation of the conductor member. Such oxidation may be significantly accelerated by the relatively high voltages (typically 120 volts to 1000 volts) employed. In order to reduce or eliminate exposure of the conductor member and the conductor portions of the cables to water, some known busbar designs include elastomeric boots or caps. These caps or boots may be difficult or inconvenient to install properly, particularly in the field, and may not provide reliable seals.

15

#### Summary of the Invention

According to embodiments of the present invention, a busbar assembly for electrically connecting a plurality of conductors includes a housing defining an interior cavity and first and second ports. The first and second ports each include a conductor passage and communicate with the interior cavity. The conductor passages are each adapted to receive a conductor therethrough. An electrically conductive busbar conductor member is disposed in the interior cavity. At least one holding mechanism is provided to selectively secure each of the conductors to the busbar conductor member for electrical contact therewith. Sealant is disposed in the conductor passages of each of the first and second ports. The sealant is adapted for insertion of the conductors therethrough such that the sealant provides a seal about the inserted conductors. The sealant may be a gel.

According to method embodiments of the present invention, a method is provided for forming a connection between an electrical connection between a busbar assembly and first and second conductors, the busbar assembly including a housing, an electrically conductive busbar conductor member, at least one holding mechanism and a sealant, the housing defining an interior cavity and first and second ports each including a conductor passage and communicating with the

30

interior cavity, the busbar member being disposed in the interior cavity, the sealant being disposed in the conductor passages of each of the first and second ports. The method includes inserting each of the first and second conductors through a respective one of the conductor passages and the sealant disposed therein and into  
5 the interior cavity such that the sealant provides a seal about the first and second conductors. The method further includes selectively securing each of the conductors to the busbar conductor member for electrical contact therewith using the at least one holding mechanism.

According to embodiments of the present invention, an electrical connector  
10 for use with a conductor includes a housing defining a port. The port includes an entrance opening, an exit opening, and a conductor passage extending between and communicating with the entrance and exit openings. The conductor passage is adapted to receive the conductor therethrough. A sleeve member is disposed in the conductor passage and defines a sleeve passage. Sealant is disposed in the sleeve  
15 passage. The sealant is adapted for insertion of the conductor therethrough such that the sealant provides a seal about the inserted conductor. The sealant may be a gel.

According to further embodiments of the present invention, an insert assembly for providing a seal to an electrical connector, the electrical connector  
20 including a housing defining a port, the port including an entrance opening, an exit opening, and a conductor passage extending between and communicating with the entrance and exit openings, the conductor passage being adapted to receive a conductor therethrough, includes a sleeve member adapted to be inserted into the conductor passage. The sleeve member defines a sleeve passage. Sealant is  
25 disposed in the sleeve passage. The sealant is adapted for insertion of the conductor therethrough such that the sealant provides a seal about the inserted conductor. The sealant may be a gel.

According to method embodiments of the present invention, a method is provided for providing a seal to an electrical connector, the electrical connector  
30 including a housing defining a port, the port including an entrance opening, an exit opening, and a conductor passage extending between and communicating with the entrance and exit openings, the conductor passage being adapted to receive a conductor therethrough. The method includes inserting an insert member into the

30253-4

conductor passage. The insert member includes a sleeve member defining a sleeve passage. The sleeve member further includes sealant disposed in the sleeve passage. The sealant is adapted for insertion of the conductor therethrough such that the sealant provides a seal about the inserted conductor.

5           According to further embodiments of the present invention, an electrical connector for use with a conductor is provided. The electrical connector defines an access opening and an access passage communicating with the access opening and includes a holding mechanism operable to secure the conductor to the electrical connector. The holding mechanism is accessible through the access opening and  
10 the access passage. Access sealant is disposed in the access passage and is adapted to seal the access passage. The access sealant may be a gel.

          According to further embodiments, an electrical connector for use with a conductor includes a housing defining a port. The port includes an entrance opening, an exit opening, and a conductor passage extending between and  
15 communicating with the entrance and exit openings. The conductor passage is adapted to receive the conductor therethrough. Sealant is disposed in the conductor passage. The sealant is adapted for insertion of the conductor therethrough such that the sealant provides a seal about the inserted conductor. A penetrable closure wall extends across the conductor passage.

20           According to further method embodiments of the present invention, a method is provided for forming a connection between an electrical connector and a conductor, the electrical connector including a housing defining a port, the port including an entrance opening, an exit opening and a conductor passage extending  
25 between and communicating with the entrance and exit openings, the electrical connector further including sealant disposed in the conductor passage and a penetrable closure wall extending across the conductor passage. The method includes inserting the conductor through the conductor passage and the sealant disposed therein such that the sealant provides a seal about the conductor. The closure wall is penetrated with the conductor.

30253-4

According to one aspect of the present invention, there is provided a busbar assembly for electrically connecting a plurality of conductors, the busbar assembly comprising: a) a housing defining: an interior cavity; and first and second ports each including a conductor passage and communicating with the interior cavity, the conductor passages each being adapted to receive a conductor therethrough; b) an electrically conductive busbar conductor member disposed in the interior cavity; c) at least one holding mechanism to selectively secure each of the conductors to the busbar conductor member for electrical contact therewith; and d) sealant disposed in the conductor passages of each of the first and second ports, the sealant being adapted for insertion of the conductors therethrough such that the sealant provides a seal about the inserted conductors.

According to another aspect of the present invention, there is provided a method for forming a connection between an electrical connection between a busbar assembly and first and second conductors, the busbar assembly including a housing, an electrically conductive busbar conductor member, at least one holding mechanism and a sealant, the housing defining an interior cavity and first and second ports each including a conductor passage and communicating with the interior cavity, the busbar member being disposed in the interior cavity, the sealant being disposed in the conductor passages of each of the first and second ports, the method comprising the steps of: a) inserting each of the first and second conductors through a respective one of the conductor passages and the sealant disposed therein and into the interior cavity such that the sealant provides a seal about the first and second conductors; and b) selectively securing each of the conductors to the busbar conductor member for electrical contact therewith using the at least one holding mechanism.

According to still another aspect of the present invention, there is provided an electrical connector for use with a conductor, the electrical connector comprising: a) a housing defining a port, the port including: an entrance opening; an exit opening; and a conductor passage extending between and communicating

30253-4

with the entrance and exit openings, the conductor passage being adapted to receive the conductor therethrough; b) sealant disposed in the conductor passage, the sealant being adapted for insertion of the conductor therethrough such that the sealant provides a seal about the inserted conductor; and c) a penetrable closure wall extending across the conductor passage, d) wherein the closure wall tapers inwardly along a direction from the entrance opening to the exit opening prior to insertion of the cable.

According to yet another aspect of the present invention, there is provided a method for forming a connection between an electrical connector and a conductor, the electrical connector including a housing defining a port, the port including an entrance opening, an exit opening and a conductor passage extending between and communicating with the entrance and exit openings, the electrical connector further including sealant disposed in the conductor passage and a penetrable closure wall extending across the conductor passage, the method comprising the steps of: a) inserting the conductor through the conductor passage and the sealant disposed therein such that the sealant provides a seal about the conductor; and b) penetrating the closure wall with the conductor, c) wherein the closure wall tapers inwardly along a direction from the entrance opening to the exit opening prior to insertion of the cable.

According to a further aspect of the present invention, there is provided an electrical connector for use with a conductor, the electrical connector comprising: a) a housing defining a port, the port including: an entrance opening; an exit opening; and a conductor passage extending between and communicating with the entrance and exit openings, the conductor passage being adapted to receive the conductor therethrough; b) a first penetrable closure wall extending across the conductor passage; c) a sleeve member disposed in the conductor passage and defining a sleeve passage, the sleeve member including a second penetrable closure wall extending across the conductor passage such that the first and second closure walls define a sealing region therebetween; and d) sealant

30253-4

disposed in the sleeve passage, the sealant being adapted for insertion of the conductor therethrough such that the sealant provides a seal about the inserted conductor; e) wherein at least a portion of the sealant is disposed in the sealing region; and f) wherein the sealant is a gel adapted to be elongated and elastically deformed by insertion of the conductor into the sealing region.

According to yet a further aspect of the present invention, there is provided a method for providing a seal to an electrical connector, the electrical connector including a housing defining a port, the port including an entrance opening, an exit opening, and a conductor passage extending between and communicating with the entrance and exit openings, the conductor passage being adapted to receive a conductor therethrough, the electrical connector further including a first penetrable closure wall extending across the conductor passage, the method comprising: providing an insert member including: a sleeve member defining a sleeve passage and including a second penetrable closure wall extending across the sleeve passage; and sealant disposed in the sleeve passage, the sealant being adapted for insertion of the conductor therethrough such that the sealant provides a seal about the inserted conductor; and inserting the insert member into the conductor passage such that the first and second closure walls define a sealing region therebetween; wherein the sealant is a gel adapted to be elongated and elastically deformed by insertion of the conductor into the sealing region.

Objects of the present invention will be appreciated by those of ordinary skill in the art from a reading of the figures and the detailed description of the preferred embodiments which follow, such description being merely illustrative of the present invention.

### **Brief Description of the Drawings**

**Figure 1** is a perspective view of an electrical connection assembly including a busbar assembly according to embodiments of the present invention and a pair of cables, wherein the cables are exploded from the busbar assembly;

**Figure 2** is an exploded, perspective view of the busbar assembly of **Figure 1**;

**Figure 3** is a cross-sectional view of the busbar assembly of **Figure 1** taken along the line 3-3 of **Figure 1**;

**Figure 4** is a cross-sectional view of the busbar assembly of **Figure 1** taken along the same line as the view of **Figure 3**, and wherein a cable is installed in the busbar assembly;

**Figure 5** is an exploded, perspective view of a busbar assembly according to further embodiments of the present invention;

**Figure 6** is a cross-sectional view of the busbar assembly of **Figure 5** taken along the line 6-6 of **Figure 5**;

**Figure 7** is a rear, perspective view of a sleeve member forming a part of the busbar assembly of **Figure 5**;

**Figure 8** is a cross-sectional view of the busbar assembly of **Figure 5** taken along the line 8-8 of **Figure 5**;

**Figure 9** is a cross-sectional view of the busbar assembly of **Figure 5** taken along the same line as the view of **Figure 8**, and wherein a cable is installed in the busbar assembly;

**Figure 10** is an exploded, perspective view of a busbar assembly according to further embodiments of the present invention;

**Figure 11** is a cross-sectional view of the busbar assembly of **Figure 10** taken along the line 11-11 of **Figure 10**;

**Figure 12** is an exploded, perspective view of a busbar assembly according to further embodiments of the present invention;

**Figure 13** is a cross-sectional view of the busbar assembly of **Figure 12** taken along the line 13-13 of **Figure 12**; and

**Figure 14** is a cross-sectional view of a busbar assembly according to further embodiments of the present invention.

### Detailed Description of the Embodiments of the Invention

The present invention now will be described more fully hereinafter with reference to the accompanying drawings, in which embodiments of the invention are shown. This invention may, however, be embodied in many different forms and should not be construed as limited to the embodiments set forth herein; rather, these embodiments are provided so that this disclosure will be thorough and complete, and will fully convey the scope of the invention to those skilled in the art. In the drawings, like numbers refer to like elements throughout.

10           With reference to **Figures 1-4**, a connector or busbar assembly **100** according to embodiments of the present invention is shown therein. The busbar assembly **100** may be used to electrically connect a plurality of electrical connectors, such as conductors **5A** and **7A** of cables **5** and **7** (which further include electrically insulative sheaths or covers **5B**, **7B**), as shown in **Figures 1** and **4**. The busbar assembly **100** may provide an environmentally protected and, preferably, watertight connector and connection. For example, the busbar assembly **100** may be used to electrically connect the conductors of a power feed cable and one or more branch or tap cables, while preventing the conductive portions of the cables and the busbar assembly **100** from being exposed to surrounding moisture or the like.

          Turning to the busbar assembly **100** in more detail, the busbar assembly **100** includes a busbar conductor member **110**, a cover assembly **120**, a plurality of set screws **102** (only two shown in **Figure 2**), and a mass of sealant **160**. The cover assembly **120** includes a rear cover member **130** and a front cover member **140**. The cover assembly **120** defines an interior cavity **122** within which the conductor member **110** is disposed. The interior cavity **122** is environmentally protected.

          The conductor member **110** includes four cable or conductor bores **112**, each having a front opening **114**. The conductor bores **112** are sized and shaped to receive the conductors **5A**, **7A**. Four threaded bores **116** extend orthogonally to and intersect respective ones of the conductor bores **112**. The conductor member **110** may be formed of any suitable electrically conductive material. In some embodiments, the conductor member **110** is formed of copper or aluminum. In

certain preferred embodiments, the conductor member 110 is formed of aluminum. The conductor member 110 may be formed by molding, stamping, extrusion and/or machining, or by any other suitable process(es).

5 The rear cover member 130 includes a body portion 132. A plurality of transversely extending ribs 133 project into the interior cavity 122 from the body portion 132. Four access ports 134 are provided on the body portion 132. Each access port 134 includes an access tube 134A defining an access passage 134B. The access passage 134B communicates with an access opening 134C and the interior cavity 122. A perimeter flange 136 extends about the body portion 132 and defines a perimeter channel 136A. A plurality of latch slots 138 are formed in the flange 136.

10 The front cover member 140 includes a body portion 142. A pair of transversely extending spacer ribs 143 (Figure 3) extend transversely to the body portion 142. Four conductor or cable ports 144 are provided on the body portion 142. Each port 144 includes a cable tube 144A defining a cable passage 144B. The cable passage 144B communicates with an entrance opening 144C and an exit opening 144D. A frangible closure wall 150 extends across the passage 144B between the openings 144C and 144D.

15 A perimeter flange 146 surrounds and projects rearwardly from the body portion 142. A plurality of barbed latch projections 148 extend rearwardly from the flange 146.

Four plugs or caps 152 are joined to the body portion 142 by a flexible connecting portion 154. The caps 152 are sized and shaped to fit in respective ones of the access passageways 134B and access openings 134C. An O-ring (e.g., 25 formed of an elastomer or the like) is provided on each cap 152 to provide a seal between the caps 152 and the access ports 134.

Preferably, the front cover member 140 is integrally formed and the rear cover member 130 is integrally formed. The cover members 130, 140 may be formed of any suitable electrically insulative material. Preferably, the cover 30 members 130, 140 are formed of a molded polymeric material. More preferably, the cover members 130, 140 are formed of polypropylene, polyethylene or a thermoplastic elastomer. The cover members 130, 140 may be formed of a flame

retardant material, and may include a suitable additive to make the cover members flame retardant.

Each of four set screws **102** (only two shown in **Figure 2**) is threadedly installed in a respective one of the threaded bores **116**. Each of the screws **102** includes a socket **102A** which may be adapted to receive a driver **9** (**Figure 4**), for example.

As best seen in **Figures 2** and **3**, the sealant **160** is disposed in the cover assembly **120**. More particularly, a body sealant portion **164** of the sealant **160** is disposed in a front portion of the interior cavity **122**. A plurality of port sealant portions **162** are disposed in respective ones of the ports **144**. In some embodiments and as illustrated, each port sealant portion **162** extends from the inner side of the closure wall **150** to the exit opening **144D** of the associated port **144** and is contiguous with the body sealant portion **164**. The sealant portion **164** includes a perimeter portion **166** that is disposed in the channel **136A** to form a surrounding seal between the cover members **130**, **140**.

According to some embodiments of the invention, the sealant **160** is a gel. The term "gel" has been used in the prior art to cover a vast array of materials from greases to thixotropic compositions to fluid-extended polymeric systems. As used herein, "gel" refers to the category of materials which are solids extended by a fluid extender. The gel may be a substantially dilute system that exhibits no steady state flow. As discussed in Ferry, "Viscoelastic Properties of Polymers," 3<sup>rd</sup> ed. P. 529 (J. Wiley & Sons, New York 1980), a polymer gel may be a cross-linked solution whether linked by chemical bonds or crystallites or some other kind of junction. The absence of the steady state flow may be considered to be the key definition of the solid-like properties while the substantial dilution may be necessary to give the relatively low modulus of gels. The solid nature may be achieved by a continuous network structure formed in the material generally through crosslinking the polymer chains through some kind of junction or the creation of domains of associated substituents of various branch chains of the polymer. The crosslinking can be either physical or chemical as long as the crosslink sites may be sustained at the use conditions of the gel.

Preferred gels for use in this invention are silicone (organopolysiloxane) gels, such as the fluid-extended systems taught in U.S. Pat. No. 4,634,207 to

Debbaut (hereinafter "Debbaut '207"); U.S. Pat. No. 4,680,233 to Camin et al.; U.S. Pat. No. 4,777,063 to Dubrow et al.; and U.S. Pat No. 5,079,300 to Dubrow et al. (hereinafter "Dubrow '300").

These fluid-extended silicone gels may be created with

5 nonreactive fluid extenders as in the previously recited patents or with an excess of a reactive liquid, e.g., a vinyl-rich silicone fluid, such that it acts like an extender, as exemplified by the Sylgard<sup>®</sup> 527 product commercially available from Dow-Corning of Midland, Michigan or as disclosed in U.S. Pat. No. 3,020,260 to Nelson. Because curing is involved in the preparation of these gels, they are  
10 sometimes referred to as thermosetting gels. An especially preferred gel is a silicone gel produced from a mixture of divinyl terminated polydimethylsiloxane, tetrakis(dimethylsiloxy)silane, a platinum divinyltetramethyldisiloxane complex, commercially available from United Chemical Technologies, Inc. of Bristol, Pennsylvania, polydimethylsiloxane, and 1,3,5,7-tetravinyltetra-  
15 methylcyclotetrasiloxane (reaction inhibitor for providing adequate pot life).

Other types of gels may be used, for example, polyurethane gels as taught in the aforementioned Debbaut '261 and U.S. Pat. No. 5,140,476 Debbaut (hereinafter "Debbaut '476") and gels based on styrene-ethylene butylenestyrene (SEBS) or styrene-ethylene propylene-styrene (SEPSS) extended with an extender  
20 oil of naphthenic or nonaromatic or low aromatic content hydrocarbon oil, as described in U.S. Pat. No. 4,369,284 to Chen; U.S. Pat. No. 4,716,183 to Gamarra et al.; and U.S. Pat. No. 4,942,270 to Gamarra. The SEBS and SEPS gels comprise glassy styrenic microphases interconnected by a fluid-extended elastomeric phase. The microphase-separated styrenic domains serve as the  
25 junction points in the systems. The SEBS and SEPS gels are examples of thermoplastic systems.

Another class of gels which may be considered are EPDM rubber based gels, as described in U.S. Pat. No. 5,177,143 to Chang et al.

Yet another class of gels which may be suitable are based on anhydride-  
30 containing polymers, as disclosed in WO 96/23007. These gels reportedly have good thermal resistance.

The gel may include a variety of additives, including stabilizers and antioxidants such as hindered phenols (e.g., Irganox<sup>™</sup> 1076, commercially

available from Ciba-Geigy Corp. of Tarrytown, New York), phosphites (e.g., Irgafos™ 168, commercially available from Ciba-Geigy Corp. of Tarrytown, New York), metal deactivators (e.g., Irganox™ D1024 from Ciba-Geigy Corp. of Tarrytown, New York), and sulfides (e.g., Cyanox LTDP, commercially available  
5 from American Cyanamid Co. of Wayne, New Jersey), light stabilizers (i.e., Cyasorb UV-531, commercially available from American Cyanamid Co. of Wayne, New Jersey), and flame retardants such as halogenated paraffins (e.g., Bromoklor 50, commercially available from Ferro Corp. of Hammond, Indiana) and/or phosphorous containing organic compounds (e.g., Fyrol PCF and Phosflex  
10 390, both commercially available from Akzo Nobel Chemicals Inc. of Dobbs Ferry, New York) and acid scavengers (e.g., DHT-4A, commercially available from Kyowa Chemical Industry Co. Ltd through Mitsui & Co. of Cleveland, Ohio, and hydrotalcite). Other suitable additives include colorants, biocides, tackifiers and the like described in "Additives for Plastics, Edition 1" published by D.A.T.A.,  
15 Inc. and The International Plastics Selector, Inc., San Diego, Calif.

The hardness, stress relaxation, and tack may be measured using a Texture Technologies Texture Analyzer TA-XT2 commercially available from Texture Technologies Corp. of Scarsdale, New York, or like machines, having a five kilogram load cell to measure force, a 5 gram trigger, and ¼ inch (6.35 mm)  
20 stainless steel ball probe as described in Dubrow '300, the disclosure of which is incorporated herein by reference in its entirety. For example, for measuring the hardness of a gel a 60mL glass vial with about 20 grams of gel, or alternately a stack of nine 2 inch x 2 inch x 1/8" thick slabs of gel, is placed in the Texture Technologies Texture Analyzer and the probe is forced into the gel at the speed of  
25 0.2 mm per sec to a penetration distance of 4.0 mm. The hardness of the gel is the force in grams, as recorded by a computer, required to force the probe at that speed to penetrate or deform the surface of the gel specified for 4.0 mm. Higher numbers signify harder gels. The data from the Texture Analyzer TA-XT2 may be analyzed on an IBM PC or like computer, running Microsystems Ltd, XT.RA Dimension  
30 Version 2.3 software.

The tack and stress relaxation are read from the stress curve generated when the XT.RA Dimension version 2.3 software automatically traces the force versus time curve experienced by the load cell when the penetration speed is 2.0

30253-4

mm/second and the probe is forced into the gel a penetration distance of about 4.0 mm. The probe is held at 4.0 mm penetration for 1 minute and withdrawn at a speed of 2.00 mm/second. The stress relaxation is the ratio of the initial force ( $F_i$ ) resisting the probe at the pre-set penetration depth minus the force resisting the probe ( $F_f$ ) after 1 min divided by the initial force  $F_i$ , expressed as a percentage. That is, percent stress relaxation is equal to

$$\frac{(F_i - F_f)}{F_i} \times 100\%$$

where  $F_i$  and  $F_f$  are in grams. In other words the stress relaxation is the ratio of the initial force minus the force after 1 minute over the initial force. It may be considered to be a measure of the ability of the gel to relax any induced compression placed on the gel. The tack may be considered to be the amount of force in grams resistance on the probe as it is pulled out of the gel when the probe is withdrawn at a speed of 2.0 mm/second from the preset penetration depth.

An alternative way to characterize the gels is by cone penetration parameters according to ASTM D-217 as proposed in Debbaut '261; Debbaut '207; Debbaut '746; and U.S. Pat. No. 5,357,057 to Debbaut et al.

Cone penetration ("CP") values may range from about 70 ( $10^{-1}$  mm) to about 400 ( $10^{-1}$  mm). Harder gels may generally have CP values from about 70 ( $10^{-1}$  mm) to about 120 ( $10^{-1}$  mm). Softer gels may generally have CP values from about 200 ( $10^{-1}$  mm) to about 400 ( $10^{-1}$  mm), with particularly preferred range of from about 250 ( $10^{-1}$  mm) to about 375 ( $10^{-1}$  mm). For a particular materials system, a relationship between CP and Voland gram hardness can be developed as proposed in U.S. Pat. No. 4,852,646 to Dittner et al.

Preferably, the gel has a Voland hardness, as measured by a texture analyzer, of between about 5 and 100 grams force, more preferably of between about 5 and 30 grams force, and, most preferably, of between about 10 and 20 grams force. Preferably, the gel has an elongation, as measured by ASTM D-638, of at least 55%, more preferably of at least 100%, and most preferably of at least 1,000%. Preferably, the gel has a stress relaxation of less than 80%, more preferably of less than 50%, and most preferably of less than 35%. The gel has a tack preferably greater than about 1 gram, more preferably greater than about 6

grams, and most preferably between about 10 and 50 grams. Suitable gel materials include POWERGEL sealant gel available from Tyco Electronics Energy Division of Fuquay-Varina, NC under the RAYCHEM brand.

Alternatively, the sealant **160** may be silicone grease or a hydrocarbon-based grease.

Referring to **Figure 4**, the busbar assembly **100** may be used in the following manner to form an electrical connection assembly **101** as shown therein. The connection assembly **101** includes the busbar assembly **100** and the cable **5**, and may include additional cables secured to the busbar assembly **100** in the manner described immediately hereinafter.

With the set screw **102** in a raised position as shown in **Figure 3**, the cable **5** is inserted into the selected port **144**. More particularly, the terminal end of the cable **5** (which has an exposed portion of the conductor **5A**) is inserted through the entrance opening **144C**, the passage **144A**, and the exit opening **144D**, and into the conductor bore **112**. In doing so, the closure wall **150** is ruptured by the cable end and the sealant **160** is displaced as shown in **Figure 4**. Preferably and as shown, the busbar assembly **100** is configured such that the interior cavity **122** includes a volume of a compressible gas (e.g., air) to allow insertion of the cable **5** without a proportionate displacement of the sealant **160** out of the interior cavity **122**.

The set screw **102** is then rotatively driven (for example, using the driver **9**) into the threaded bore **116** to force the exposed portion of the conductor **5A** against the opposing wall of the bore **112**. The cap **152** is then replaced over the access opening **134C**.

In this manner, the cable **5** is mechanically secured to or captured within the busbar assembly **100** and electrically connected to the conductor member **110**. One or more additional cables may be inserted through the other ports **144** and secured using the other set screws **102**. In this manner, such other cables are thereby electrically connected to the cable **5** and to one another through the conductor member **110**.

When, as preferred, the sealant **160** is a gel, the cable **5** and the tube **144A** apply a compressive force to the sealant **160** as the cable **5** is inserted into the busbar assembly **100**. The gel is thereby elongated and is generally deformed and substantially conforms to the outer surface of the cable **5** and to the inner surface of

the tube 144A. The elongated gel may extend into and through the conductor bore 112. Moreover, the elongated gel may extend beyond the conductor member 110 into an expansion chamber 135 created by the ribs 133. Some shearing of the gel may occur as well. Preferably, at least some of the gel deformation is elastic. The restoring force in the gel resulting from this elastic deformation causes the gel to operate as a spring exerting an outward force between the tube 144 and the cable 5.

The ruptured closure wall 150 may serve to prevent or limit displacement of the gel sealant 160 out of the port 144 toward the entrance opening 144C, thereby promoting displacement of the gel into the interior cavity 122. Preferably, the busbar assembly is adapted such that, when the cable 5 is installed, the gel has an elongation at the interface between the gel 160 and the inner surface of the tube 144A of at least 20%.

Each of the closure walls 150 serves as a dam for the gel or other sealant 160 in use. Additionally, the closure walls 150 serve as mechanical covers (for example, to prevent or reduce the entry of dust and the like). Moreover, the closure walls 150 may serve as dams for the gel or other sealant 160 during manufacture, as described below. It will be appreciated that, in some embodiments of the present invention, the closure walls 150 can be omitted.

The busbar assembly 100 may provide a reliable (and, in at least some embodiments, moisture-tight) seal between the busbar assembly 100 and the cable 5, as well as any additional cables secured in the ports 144. The sealant 160, particularly gel sealant, may accommodate cables of different sizes within a prescribed range. The ports 144 which do not have cables installed therein are likewise sealed by the sealant 160. Upon removal of a cable, the associated port 144 may be resealed by the re-formation of the gel sealant 160.

Various properties of the gel, as described above may ensure that the gel sealant 160 maintains a reliable and long lasting hermetic seal between the tube 144A and the cable 5. The elastic memory of and the retained or restoring force in the elongated, elastically deformed gel generally cause the gel to bear against the mating surfaces of the cable 5 and the interior surface of the tube 144A. Also, the tack of the gel may provide adhesion between the gel and these surfaces. The gel, even though it is cold-applied, is generally able to flow about the cable 5 and the connector 100 to accommodate their irregular geometries.

Preferably, the sealant **160** is a self-healing or self-amalgamating gel. This characteristic, combined with the aforementioned compressive force between the cable **5** and the tube **144A**, may allow the sealant **160** to re-form into a continuous body if the gel is sheared by the insertion of the cable **5** into the connector **100**.

5 The gel may also re-form if the cable **5** is withdrawn from the gel.

The sealant **160**, particularly when formed of a gel as described herein, may provide a reliable moisture barrier for the cable **5** and the conductor member **110**, even when the connection **101** is submerged or subjected to extreme temperatures and temperature changes. Preferably, the cover members **130**, **140** are made from an  
10 abrasion resistant material that resists being punctured by the abrasive forces.

The gel may also serve to reduce or prevent fire. The gel is typically a more efficient thermal conductor than air and, thereby, may conduct more heat from the connection. In this manner, the gel may reduce the tendency for overheating of the connection **101** that might otherwise tend to deteriorate the cable insulation and cause  
15 thermal runaway and ensuing electrical arcing at the connection **101**. Moreover, the gel may be flame retardant.

The busbar assembly **100** may be formed in the following manner. If the sealant **160** requires curing, such as a curable gel, the sealant may be cured *in situ*. The front cover member **140** is oriented vertically with the body portion **142** over the  
20 ports **144**. Liquid, uncured sealant is dispensed into the front cover member **140**, such that it fills the cable passages **144B** above the closure walls **150** and also fills a portion of the body member **142** (the flange **146** serving as a surrounding side dam). The sealant is then cured *in situ*.

The cover members **130**, **140** are then joined and interlocked by means of the  
25 latch slots **138** and the latch projections **148** about the conductor member **110**. The set screws **102** are installed in the threaded bores **116** through the access ports **134**. The O-rings **156** are installed on the caps **152**.

According to some embodiments, the following dimensions may be preferred. Preferably, the length **L1** (**Figure 3**) of the cable passages **144B** is at least 1.0 inch  
30 and, more preferably, between about 1.0 and 2.5 inch. Preferably, the length **L2** (**Figure 3**) of the sealant **160** is at least 0.75 inch and, more preferably, between about 0.75 and 2.25 inch. Preferably, the nominal diameter **D1** (**Figure 3**) of the cable passages **144B** is at least 1.0 inch. More preferably, the diameter **D1** is between

about 1.0 and 2.0 inches. Preferably, the diameter **D1** is between about 15 and 30% greater than the diameter of the largest cable (including insulative cover) the port **144** is intended to accommodate. Preferably, the busbar assembly **100** is adapted to accommodate cables having a full diameter (including insulative cover) of between  
5 about 0.125 and 0.875 inch. Preferably, the expansion chamber **135** has a volume of at least 1.0 in<sup>3</sup>.

Preferably, each closure wall **150** has a maximum thickness **T1** (**Figure 3**) of no more than 0.25 inch, and more preferably between about 0.005 and 0.125 inch. Preferably, each closure wall **150** has an insertion force (*i.e.*, force required to  
10 penetrate the plane of the closure wall **150** with the intended cable) of between about 1 lb. and 40 lbs and, more preferably, of between about 1 lb and 10 lbs. Each closure wall **150** may be molded with lines of reduced thickness or pre-cut or slotted after molding to create tear lines **150A** (**Figure 1**) that reduce the required assembly force to the desired level. Each closure wall **150** may be constructed as a membrane that  
15 substantially entirely seals the conductor passage **144B** prior to being ruptured.

With reference to **Figures 5-9**, a busbar assembly **200** according to further embodiments of the present invention is shown therein. The busbar assembly **200** includes a busbar conductor member **210**, a cover member **220**, four set screws **202**, four caps **252**, and four insert assemblies **270**. **Figure 9** shows an electrical  
20 connection assembly **201** including a cable **5** connected to the busbar assembly **200**.

The conductor member **210** includes conductor bores **212**, front openings **214** and threaded bores **218** corresponding to elements **112**, **114**, **118** as discussed above, except that the conductor bores **212** do not extend all the way through the conductor member **210**. However, it will be appreciated that the conductor bores **212** may be  
25 formed in the same fashion as the conductor bores **112**.

The cover member **220** is a one piece design and includes four access ports **234** corresponding to the access ports **134**. The cover member **220** also includes four cable ports **244** corresponding to the cable ports **144** except the cable passages **244B** preferably have a slightly larger interior diameter. The caps **252** are separately  
30 formed and adapted to removably seal the access ports **234**.

Each insert assembly **270** is positioned in a respective one of the cable ports **244**. Each insert assembly **270** has a sleeve member **272**. Each sleeve member **272** defines a passage **272A**, an entrance opening **272B**, and an exit opening **272C**.

Each sleeve member **272** has an outwardly extending flange **272D** surrounding its entrance opening **272B**. A closure wall **274** extends across the passage **272A** of each sleeve member **272**. Each insert assembly **270** includes a mass of sealant **276** disposed in the passage **272A** thereof.

5           The sleeve members **272** may be formed of any suitable material. According to some embodiments, the sleeve members **272** are formed of a polymeric material such as polypropylene, polyethylene, or polyurethane.

          According to some embodiments, the sealant **276** is a gel as described above. Each insert assembly **270** is positioned in the cable passage **244B** of the  
10 associated port **244** such that the sealant **276** is positioned between the entrance opening **244C** and the exit opening **244D** in the passage **244B** of the cable tube **244A**. The insert assembly **270** is maintained in position by the flange **272D**, which limits insertion depth, and a frictional fit, welding, adhesive or other suitable  
15 securement between the outer wall of the sleeve member **272** and the inner wall of the cable tube **244A**. Ribs **272E** extend lengthwise along and project into the passage **272A**. The ribs **272E** provide additional surface area for holding the sealant **276**.

          Preferably, sleeve member passages **272A** and the masses of sealant **276** have dimensions corresponding to those discussed above with regard to the cable  
20 passages **144A** and the sealant **160**, respectively. According to some embodiments, the wall thickness of the sleeve member **272** is no greater than 0.125 inch.

          The busbar assembly **200** may be used in the same manner as described above for the busbar assembly **100**. The busbar assembly **200** may be preferred for  
25 ease of assembly, particularly where a one-piece cover member **220** is desired. The insert assemblies **270** may be separately molded or otherwise formed. The sealant **276**, such as a gel, may be installed in the sleeve members **272** by curing *in situ* in the manner described above for the cover member **240** and the gel sealant **160**. The cover member **220** may be molded about the conductor member **210** in  
30 conventional manner. The insert assemblies **270** may then be inserted into the respective cable ports **244** and suitably secured in place. The insert assemblies **270** may also be used to retrofit conventional busbar connectors.

With reference to **Figures 10 and 11**, a busbar assembly **300** according to further embodiments of the present invention is shown therein. The busbar assembly **300** corresponds to the busbar assembly **100**, except as follows. The access tubes **334A** of the access ports **334** are shortened and a cap assembly **380** is installed over each. Each cap assembly **380** includes a cap body **382** defining a passage **382A**. Each cap body **382** includes a flange **384** and a closure wall **386**. Each cap body **382** is secured, for example, by friction fit, welding, adhesive, snap latch and/or other suitable means, to a respective one of the access tubes **334A**. A mass of sealant **388**, preferably a gel as described above, is disposed in each passage **382A** and in an upper portion of the associated access tube **334A**. The masses of sealant **388** and the closure walls **386** serve to protect the busbar assembly **300** from the infiltration of moisture and/or contaminants.

The busbar assembly **300** may be used in the same manner as the busbar assembly **100** except that, in order to rotate each set screw **302** to secure or release a cable, the driver **9** is inserted through the closure wall **386** and the sealant **388**. After the screw **302** is positioned as desired, the driver **9** is withdrawn from the sealant **388**. Where, as preferred, the sealant **388** is a gel as described above, the gel **388** re-forms to again form a barrier to prevent or reduce infiltration of moisture and contaminants.

The cap bodies **382** are preferably formed of the same material as the sleeve members **272** as described above. The sealant (for example, a gel) may be installed in the same manner as the sealant **276**. According to alternative embodiments, the cap bodies **382** may be integrally formed with the access tubes **334A**.

With reference to **Figures 12 and 13**, a busbar assembly **400** according to further embodiments of the present invention is shown therein. The busbar assembly **400** corresponds to the busbar assembly **100**, except as follows. The busbar assembly **400** includes a conductor member **410**, a cover assembly **420**, cover members **430**, **440**, and sealant **460** generally corresponding to the elements **110**, **120**, **130**, **140** and **160** discussed above, respectively. Each port **444** includes a cable tube **444A** defining a cable passage **444B**. The cable passage **444B** communicates with an entrance opening **444C** and an exit opening **444D**.

A penetrable closure wall **451** extends across the passage **444B** between the openings **444C** and **444D**. The closure wall **451** may be integrally molded with the tube **444A**. With reference to **Figure 13**, the closure wall **451** includes a plurality of discrete fingers or flaps **452** separated by gaps **452A**. The flaps **452** are flexible. According to some embodiments, the flaps **452** are also resilient.

According to some embodiments, the flaps **452** are concentrically arranged and taper inwardly in a direction **A** from the entrance opening **444C** to the exit opening **444D** to form a generally conical or frusto-conical shape. According to some embodiments, the angle of taper is between about 10 and 60 degrees. The closure wall **451** defines a hole **452B** that may be centrally located. According to some embodiments, the inner diameter **D2** of the hole **452B** is less than the outer diameter of the cable or cables (*e.g.*, the cables **5**, **7**) with which the assembly **400** is intended to be used. The thickness of the flaps **452** may taper in a radially inward direction. According to some embodiments, the thickness of the flaps **452** tapers in the radially inward direction at a rate of between about zero and 50 percent/inch.

An insert member **490** is positioned in the passage **444B** adjacent the exit opening **444D**. The insert member **490** is seated in a recess **444E** in the tube **444A** and positively captured between a ledge **444F** and the front face of the conductor member **410**. Additionally or alternatively, the insert member **490** may be otherwise secured within the passage **444B**, for example, by welding, adhesive, friction fit, a mechanical latch or latches, one or more fasteners or the like.

The insert member **490** includes a tubular body defining a passage **490A**. The insert member **490** further includes a penetrable closure wall **491** extending across the passage **490A**. The closure wall **491** may be integrally formed with the body **493**. The closure wall **491** may be constructed in the same manner as discussed above with regard to the closure wall **451**, and includes a plurality of flaps **492** separated by gaps **492A** and defining a hole **492B**.

The closure walls **451** and **491** define a sealing chamber or region **499** therebetween (**Figure 13**). A portion **462** of the sealant **460** is disposed in the sealing region **499**. According to some embodiments, the sealant **462** substantially fills the sealing region **499**. A further portion **464** of the sealant **460** is disposed

between the closure wall **491** and the conductor member **410**. A further portion **466** of the sealant **460** is disposed in the channel **436A**.

The assembly **400** may be used in the same manner as the assembly **100** to provided an environmentally protected connection between conductors (*e.g.*, of the cables **5**, **7**). Upon insertion of a cable through one of the ports **444**, the cable penetrates and displaces the closure wall **451**. The cable may elastically deflect the flaps **452** as the cable passes through the hole **452B**. As the cable is further inserted, the cable passes through and displaces the sealant portion **462**. The cable thereafter penetrates and displaces the closure wall **491** and passes into the interior cavity **422** of the housing **420**. The cable is inserted into the conductor member **410** and secured using the set screw as described above.

The closure walls **451** and **491** may serve to retain the sealant **462** in the sealing region **499** to improve the sealing performance of the connector assembly **400**. By retaining the sealant **462** in the sealing region **499**, a suitable amount of compressive force can be maintained between the sealant and the surfaces to be sealed. Moreover, a sufficient amount of the sealant may be retained in the sealing passage to re-form into a sealing plug upon removal of the cable from the port **444**. In the absence of the closure wall **491**, there may be a tendency for the cable to displace the sealant **462** into the interior cavity **422** so that there is insufficient sealant **462** remaining in the passage **444B** (and, more particularly, in the passage **499**) to effectively seal about the cable or to seal upon removal of the cable. The closure wall **451** may likewise serve to retain the sealant **462** in the sealing region **499** as the cable is withdrawn from the port **444**. The closure walls **451**, **491** may wipe the sealant **462** from the cable as the cable is inserted therethrough. Thus, the closure walls **451**, **491** may reduce the amount of sealant needed to provide the desired sealing performance, particularly in the case of multiple insertions and removals of the cable or cables.

Features directed to addressing other concerns may exacerbate the foregoing problems. For example, it may be desirable or even required that a chamber **435** be provided beyond the set screw **402** to allow an additional length of the conductor of the cable to be inserted into the conductor block **410**. This additional length may serve to provide a greater margin for error in installing the cable and to improve the integrity of the securement (*e.g.*, to reduce the risk of

extruding the cable out from beneath the set screw 402). However, the chamber 435 may allow an undesirably great amount of the sealant 462 to be displaced from the passage 444B. The closure wall 491, by preventing or limiting the displacement of the sealant 462 into the chamber 435, allows for the provision of the chamber 435 without an undue loss of sealing performance.

The busbar assembly 400 may be formed in the same manner as the assembly 100 as discussed above. However, in the case of the assembly 400, the insert member 490 may be placed in the recess 444E before curing the sealant 460 (and typically before dispensing the uncured sealant into the front cover member 440). In this manner, the sealant 460 may help to secure the insert member 490 in place in the front cover member 440.

With reference to **Figure 14**, a busbar assembly 500 according to further embodiments of the present invention is shown therein. The busbar assembly 500 corresponds to the busbar assembly 200, except as follows.

The busbar assembly 500 includes an insert assembly 570 in one or more ports 544 (one shown in **Figure 14**). The insert assembly 570 corresponds to the insert member 270, except as follows. The insert assembly 570 has a penetrable closure wall 551 constructed as described above for the closure wall 451 in place of the frangible closure wall 274. The insert member 570 additionally includes an insert member 590 corresponding to the insert member 490 and secured (*e.g.*, by holding, adhesive, friction fit, or other suitable means) in the passage 544A of the sleeve 572. The insert member 590 includes a further penetrable closure wall 591 constructed as described above for the closure wall 491. The closure walls 551 and 591 define a sealing chamber or region 599 therebetween. Sealant 562 is disposed in the sealing region 599. According to some embodiments, the sealant 562 substantially fills the sealing region 599. According to some embodiments, and as shown, the sealant 562 extends to the exit opening 572C.

The assembly 500 may be used in the same manner as the assembly 200 as described above. However, by provision of the additional closure wall 591, the assembly 500, and more particularly, the insert assembly 570, can provide the advantages discussed above with regard to the busbar assembly 400.

Where the closure walls 150, 274, 386, 451, 491, 551 and 591 are elastically resilient, they will be spring biased against the outer surface of the

inserted cable when displaced by the cable. This biased engagement may serve to enhance the engagement of the closure wall against the cable to thereby retain the pressure on the sealant. The biased engagement may also serve to improve the wiping effect as the cable is inserted or withdrawn. The geometry of the closure wall may further assist in improving the seal and wiping effect.

Various modifications may be made to the foregoing busbar assemblies 100, 200, 300, 400, 500 in accordance with the present invention. For example, the body sealant portion 164 may be omitted. According to some embodiments, the closure walls 150, 274, 386 may be omitted.

The closure walls 150, 274, 386 may be otherwise constructed so as to be penetrable and displaceable. For example, the closure walls 150, 274, 386 may be constructed in the manner described above for the closure walls 451, 491, 551, 591. Similarly, the closure walls 451, 491, 551, 591 may be constructed so as to be fully or partly frangible. Closure walls of different designs and constructions may be used in the same connector as well as in the same port. For example, the outer closure wall may be frangible and formed as described for the closure wall 150 while the inner closure wall is formed as described for the closure wall 451.

Moreover, various features of the above-described closure walls may be combined. For example, one or more of the closure walls may be frangible with a pre-formed hole corresponding to the hole 452B formed therein and/or with a tapered shape. The closure walls including a plurality of flaps may be formed such that they do not form a pre-defined hole (*e.g.*, the hole 452B). As a further alternative, each closure wall may be constructed as a resilient, elastic membrane or panel having a preformed hole therein, the closure wall being adapted to stretch about the hole to accommodate the penetrating cable without rupturing. In such case, the hole is preferably smaller in diameter than the outer diameter of the intended cable.

The insert assembly 570 may be of a one piece construction wherein the closure wall 591 is integrally molded with the sleeve 572 of the insert member 570. The closure wall 491 may be integrally molded with or otherwise secured to the tube 444A without using a separate insert member 490, for example.

The inner closure walls (*e.g.*, closure walls 491, 591) may be used without the outer closure walls (*e.g.*, closure walls 451, 551). More than two closure walls

may be employed. For example, a third closure wall may extend across the cable passage **444B** in the sealing region **499**.

While three or four cable ports and conductor bores and three or four access ports, screw bores and set screws are shown in each of the busbar assemblies **100**,  
5 **200, 300, 400, 500**, busbar assemblies according to the present invention may include more or fewer cable ports and/or access ports and corresponding or associated components as needed to allow for the connection of more or fewer cables.

Various of the features and inventions discussed herein may be combined  
10 differently than in the embodiments illustrated. For example, the cap assemblies **380** may be used in the connector **200** as well.

While the present invention has been described herein with reference to busbar assemblies, various of the features and inventions discussed herein may be provided in other types of connectors. For example, the penetrable closure walls  
15 and insert assemblies may be employed in connectors for securing a single cable or the like.

While, in accordance with some embodiments, the sealants **160, 276, 388, 460, 562** are gels as described above, other types of sealants may be employed.

Connectors according to the present invention may be adapted for various  
20 ranges of voltage. It is particularly contemplated that multi-tap connectors of the present invention employing aspects as described above may be adapted to effectively handle voltages in the range of 120 to 1000 volts.

The foregoing is illustrative of the present invention and is not to be construed as limiting thereof. Although a few exemplary embodiments of this  
25 invention have been described, those skilled in the art will readily appreciate that many modifications are possible in the exemplary embodiments without materially departing from the novel teachings and advantages of this invention. Accordingly, all such modifications are intended to be included within the scope of this invention. Therefore, it is to be understood that the foregoing is illustrative of the  
30 present invention and is not to be construed as limited to the specific embodiments disclosed, and that modifications to the disclosed embodiments, as well as other embodiments, are intended to be included within the scope of the invention.

30253-4

CLAIMS:

1. A busbar assembly for electrically connecting a plurality of conductors, the busbar assembly comprising:
- a) a housing defining:
- 5 an interior cavity; and
- first and second ports each including a conductor passage and communicating with the interior cavity, the conductor passages each being adapted to receive a conductor therethrough;
- b) an electrically conductive busbar conductor member disposed in the
- 10 interior cavity;
- c) at least one holding mechanism to selectively secure each of the conductors to the busbar conductor member for electrical contact therewith; and
- d) sealant disposed in the conductor passages of each of the first and second ports, the sealant being adapted for insertion of the conductors therethrough
- 15 such that the sealant provides a seal about the inserted conductors.
2. The busbar assembly of Claim 1 wherein the sealant is a gel.
3. The busbar assembly of Claim 2 wherein the gel is adapted to be elongated and elastically deformed by insertion of the conductors into the conductor passages.
- 20 4. The busbar assembly of any one of Claims 1 to 3, wherein:
- each of the first and second ports includes a penetrable closure wall extending across the respective conductor passage; and
- at least portions of the sealant are disposed in the conductor passages between the closure walls and the interior cavity.

30253-4

5. The busbar assembly of Claim 4 wherein the closure walls are frangible.
6. The busbar assembly of Claim 4 or 5 wherein the closure walls have a thickness of no more than 0.25 inch.
7. The busbar assembly of any one of Claims 1 to 6, wherein the housing  
5 includes a projection extending into at least one of the conductor passages to increase surface contact between the housing and the sealant in the conductor passage.
8. The busbar assembly of Claim 1 wherein:  
  
the housing includes first and second housing parts mated to one  
another; and  
10 the busbar assembly further includes a joiner sealant along an interface between the first and second housing parts.
9. The busbar assembly of Claim 8 wherein the joiner sealant is a gel.
10. The busbar assembly of Claim 1 including a sleeve member disposed in  
at least one of the conductor passages, wherein the sealant is disposed in the sleeve  
15 member.
11. The busbar assembly of Claim 1 wherein the at least one holding mechanism includes first and second set screws.
12. The busbar assembly of Claim 11 wherein the housing includes first  
and second access openings adapted to receive a tool therethrough for rotating the  
20 first and second set screws.
13. The busbar assembly of Claim 12 including:  
  
first and second access passages communicating with the first and  
second access openings and adapted to receive a tool therethrough for rotating the  
first and second set screws; and

30253-4

access sealant disposed in each of the first and second access passages, the access sealant being adapted to seal the first and second access passages and to allow insertion of the tool therethrough to rotate the first and second set screws.

5 14. The busbar assembly of Claim 13 wherein the interior cavity includes a volume filled with a compressible fluid to receive the sealant when the sealant is displaced by the conductors.

15. The electrical connector of Claim 1 wherein:  
the housing defines an interior cavity communicating with the conductor  
10 passage;

a conductor member is positioned in the interior cavity;

the interior cavity includes a volume filled with a compressible gas to receive the sealant when the sealant is displaced by the conductor; and

15 the volume is located on a side of the sealant opposite the entrance opening.

16. A method for forming a connection between an electrical connection between a busbar assembly and first and second conductors, the busbar assembly including a housing, an electrically conductive busbar conductor member, at least one holding mechanism and a sealant, the housing defining an interior cavity and first  
20 and second ports each including a conductor passage and communicating with the interior cavity, the busbar member being disposed in the interior cavity, the sealant being disposed in the conductor passages of each of the first and second ports, the method comprising the steps of:

a) inserting each of the first and second conductors through a respective  
25 one of the conductor passages and the sealant disposed therein and into the interior cavity such that the sealant provides a seal about the first and second conductors; and

30253-4

b) selectively securing each of the conductors to the busbar conductor member for electrical contact therewith using the at least one holding mechanism.

17. The method of Claim 16 further including withdrawing the first conductor from the respective conductor passage such that the sealant therein re-forms to seal  
5 the conductor passage.

18. The method of Claim 16 or 17, wherein the step of inserting each of the first and second conductors through a respective one of the conductor passages includes puncturing a closure wall extending across at least one of the conductor passages.

10 19. An electrical connector for use with a conductor, the electrical connector comprising:

a) a housing defining a port, the port including:

an entrance opening;

an exit opening; and

15 a conductor passage extending between and communicating with the entrance and exit openings, the conductor passage being adapted to receive the conductor therethrough;

20 b) sealant disposed in the conductor passage, the sealant being adapted for insertion of the conductor therethrough such that the sealant provides a seal about the inserted conductor; and

c) a penetrable closure wall extending across the conductor passage,

d) wherein the closure wall tapers inwardly along a direction from the entrance opening to the exit opening prior to insertion of the cable.

30253-4

20. The electrical connector of Claim 19 wherein the closure wall is operative to retain the sealant in the passage.
21. The electrical connector of Claim 19 or 20, wherein the closure wall is frangible.
- 5 22. The electrical connector of Claim 21 wherein the closure wall includes a membrane substantially entirely sealing the passage.
23. The electrical connector of Claim 19 wherein the closure wall includes a plurality of discrete flaps.
24. The electrical connector of Claim 19 wherein the closure wall defines a  
10 hole adapted to receive the conductor.
25. The electrical connector of Claim 24 wherein the hole has an inner diameter smaller than an outer diameter of the conductor.
26. The electrical connector of any one of Claims 19 to 25, wherein the closure wall has a thickness of no more than 0.25 inch.
- 15 27. The electrical connector of Claim 19 wherein the closure wall is formed of a polymeric material.
28. The electrical connector of any one of Claims 19 to 27, wherein at least a portion of the sealant is disposed in the conductor passage between the closure wall and the exit opening.
- 20 29. The electrical connector of any one of Claims 19 to 28, wherein at least a portion of the sealant is disposed in the conductor passage between the closure wall and the entrance opening.
30. The electrical connector of Claim 19 wherein the closure wall is integrally molded with the housing.

30253-4

31. The electrical connector of Claim 19 including an insert member separately formed from the housing and positioned in the conductor passage, wherein the closure wall forms a part of the insert member.

32. The electrical connector of Claim 31 wherein the housing includes a ledge adapted to locate the insert member in the conductor passage.

33. The electrical connector of Claim 32 further including a conductor member positioned in the housing such that the insert member is cooperatively secured in the conductor passage by the conductor member and the ledge.

34. The electrical connector of Claim 19 including a second penetrable closure wall extending across the conductor passage such that the first and second closure walls define a sealing region therebetween, wherein at least a portion of the sealant is disposed in the sealing region.

35. The electrical connector of Claim 34 wherein the first and second closure walls are operative to retain the sealant in the sealing region.

36. The electrical connector of Claim 34 including an insert member separately formed from the housing and positioned in the conductor passage, wherein at least one of the first and second closure walls forms a part of the insert member.

37. The electrical connector of Claim 36 wherein the first closure wall is integrally formed with the housing and the second closure wall forms a part of the insert member.

38. The electrical connector of Claim 37 wherein:

each of the first and second closure walls forms a part of the insert member; and

the insert member defines an insert passage including the sealing region.

30253-4

39. The electrical connector of Claim 34 wherein at least one of the first and second closure walls is frangible.

40. The electrical connector of Claim 34 wherein at least one of the first and second closure walls includes a plurality of discrete flaps.

5 41. The electrical connector of Claim 34 wherein at least one of the first and second closure walls defines a hole adapted to receive the conductor.

42. The electrical connector of any one of Claims 19 to 42, wherein the sealant is a gel.

10 43. The electrical connector of Claim 42 wherein the gel is adapted to be elongated and elastically deformed by insertion of the conductor into the conductor passage.

44. The electrical connector of Claim 35 wherein the sealant is a gel adapted to be elongated and elastically deformed by insertion of the conductor into the sealing region.

15 45. The electrical connector of Claim 19 wherein:

a) the housing defines a second port and an interior cavity, the second port including:

a second entrance opening;

a second exit opening; and

20 a second conductor passage extending between and communicating with the second entrance opening and the second exit opening, the second conductor passage being adapted to receive a second conductor therethrough;

30253-4

b) sealant is disposed in the second conductor passage, the sealant being adapted for insertion of the second conductor therethrough such that the sealant provides a seal about the inserted second conductor;

5 c) a second penetrable closure wall extends across the second conductor passage;

d) each of the first and second ports communicates with the interior cavity; and

e) the electrical connector includes:

10 an electrically conductive busbar conductor member disposed in the interior cavity; and

at least one holding mechanism to selectively secure each of the conductors to the busbar conductor member for electrical contact therewith.

46. A method for forming a connection between an electrical connector and a conductor, the electrical connector including a housing defining a port, the port including an entrance opening, an exit opening and a conductor passage extending between and communicating with the entrance and exit openings, the electrical connector further including sealant disposed in the conductor passage and a penetrable closure wall extending across the conductor passage, the method comprising the steps of:

15

20 a) inserting the conductor through the conductor passage and the sealant disposed therein such that the sealant provides a seal about the conductor; and

b) penetrating the closure wall with the conductor,

25 c) wherein the closure wall tapers inwardly along a direction from the entrance opening to the exit opening prior to insertion of the cable.

30253-4

47. The method of Claim 46 wherein the closure wall is frangible and the step of inserting the conductor through the conductor passage includes puncturing the closure wall.

48. The method of Claim 46 wherein the closure wall includes a plurality of discrete flaps and the step of inserting the conductor through the conductor passage includes deflecting at least one of the flaps.

49. The method of any one of Claims 46 to 48, further including penetrating a second closure wall with the conductor, wherein the second closure wall extends across the conductor passage such that the first and second closure walls define a sealing region therebetween, and wherein the sealant is disposed in the sealing region.

50. An electrical connector for use with a conductor, the electrical connector comprising:

a) a housing defining a port, the port including:

an entrance opening;

15 an exit opening; and

a conductor passage extending between and communicating with the entrance and exit openings, the conductor passage being adapted to receive the conductor therethrough;

20 b) a first penetrable closure wall extending across the conductor passage;

c) a sleeve member disposed in the conductor passage and defining a sleeve passage, the sleeve member including a second penetrable closure wall extending across the conductor passage such that the first and second closure walls define a sealing region therebetween; and

30253-4

d) sealant disposed in the sleeve passage, the sealant being adapted for insertion of the conductor therethrough such that the sealant provides a seal about the inserted conductor;

5 e) wherein at least a portion of the sealant is disposed in the sealing region; and

f) wherein the sealant is a gel adapted to be elongated and elastically deformed by insertion of the conductor into the sealing region.

51. The electrical connector of Claim 50 wherein the sleeve member includes a projection extending into the sleeve passage to increase surface contact  
10 between the sleeve member and the sealant in the sleeve passage.

52. The electrical connector of Claim 50 including a penetrable closure wall extending across the sleeve passage.

53. The electrical connector of Claim 52 wherein the closure wall is frangible.

15 54. The electrical connector of Claim 52 or 53 including a second penetrable closure wall extending across the sleeve passage such that the first and second closure walls define a sealing region therebetween, wherein at least a portion of the sealant is disposed in the sealing region.

20 55. The electrical connector of Claim 52 wherein the first and second closure walls are formed of a polymeric material.

56. The electrical connector of any one of Claims 50 to 55 wherein the sleeve member has a wall thickness of no greater than 1/8 inch.

57. The electrical connector of Claim 56 wherein the sleeve member has a wall thickness of between about 0.015 and 0.100 inch.

30253-4

58. The electrical connector of any one of Claims 50 to 57, wherein the sleeve member is formed of a polymeric material.

59. The electrical connector of any one of Claims 50 to 58, wherein the sealant is a gel.

5 60. The electrical connector of Claim 59 wherein the gel is adapted to be elongated and elastically deformed by insertion of the conductor into the conductor passage.

61. A method for providing a seal to an electrical connector, the electrical connector including a housing defining a port, the port including an entrance opening,  
10 an exit opening, and a conductor passage extending between and communicating with the entrance and exit openings, the conductor passage being adapted to receive a conductor therethrough, the electrical connector further including a first penetrable closure wall extending across the conductor passage, the method comprising:

providing an insert member including:

15 a sleeve member defining a sleeve passage and including a second penetrable closure wall extending across the sleeve passage; and

sealant disposed in the sleeve passage, the sealant being adapted for insertion of the conductor therethrough such that the sealant provides a seal about the inserted conductor; and

20 inserting the insert member into the conductor passage such that the first and second closure walls define a sealing region therebetween;

wherein the sealant is a gel adapted to be elongated and elastically deformed by insertion of the conductor into the sealing region.

62. The method of Claim 61 including the step of securing the sleeve  
25 member in the conductor passage.

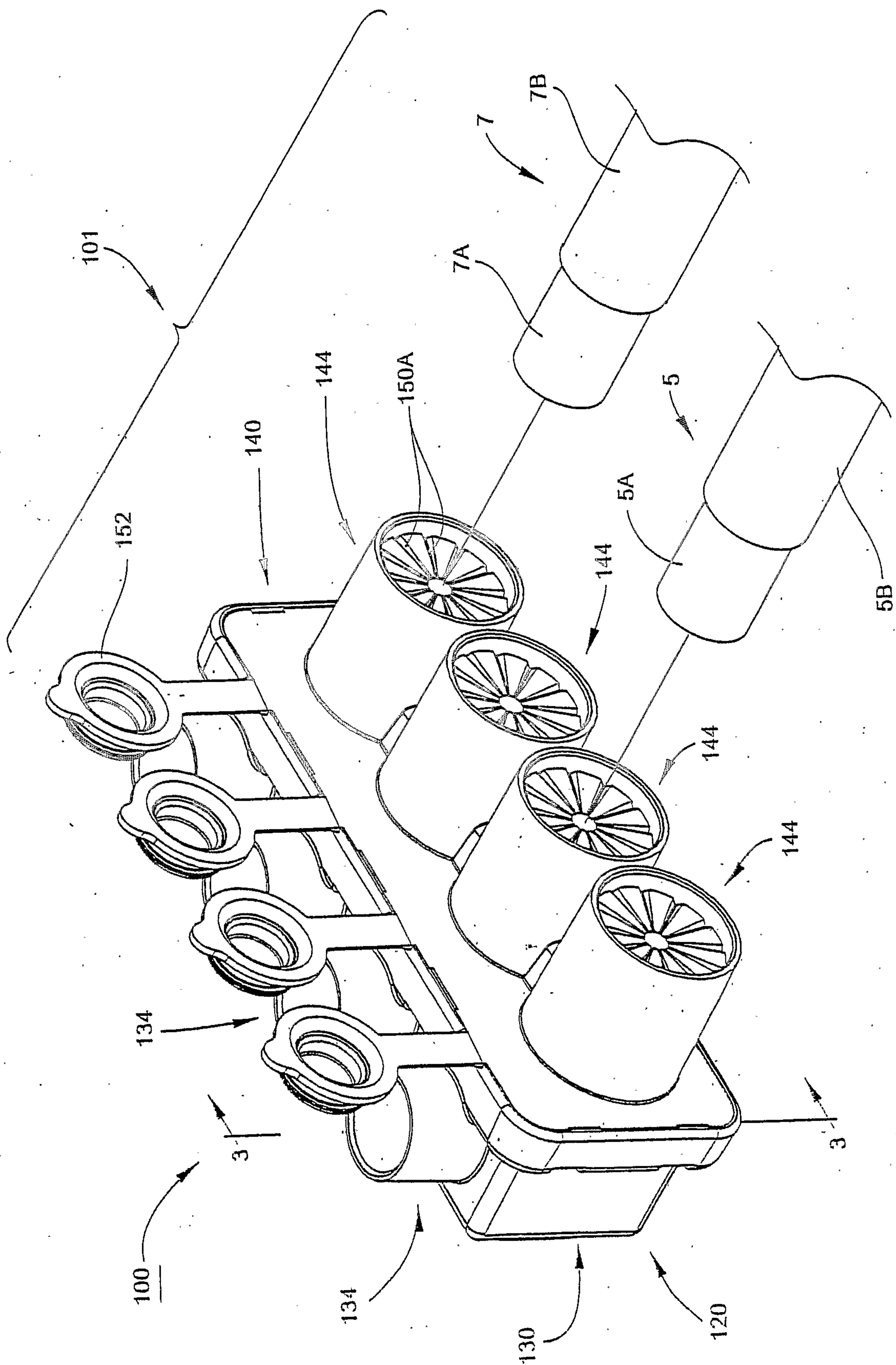

Fig. 1



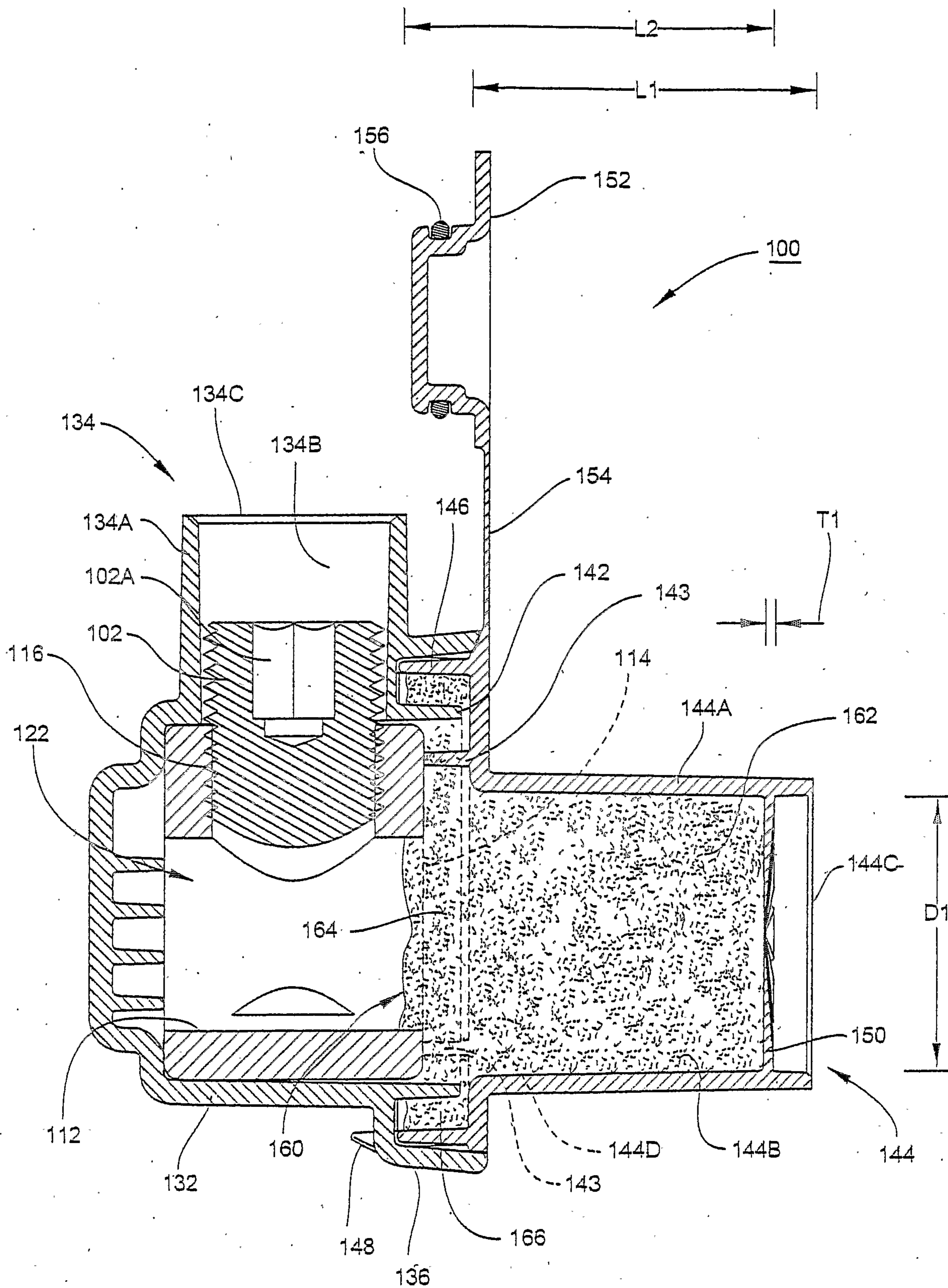

Fig. 3



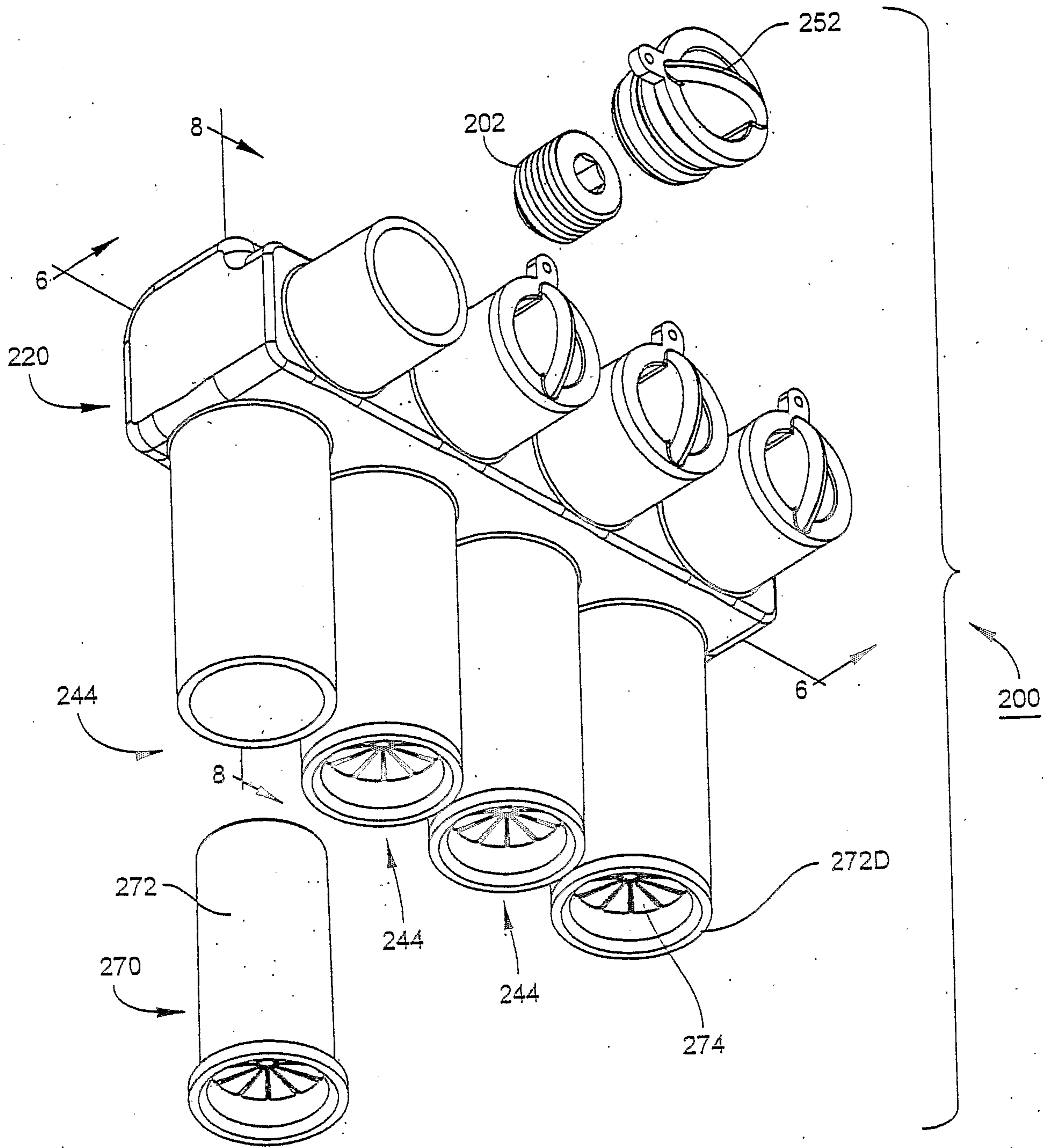

Fig. 5

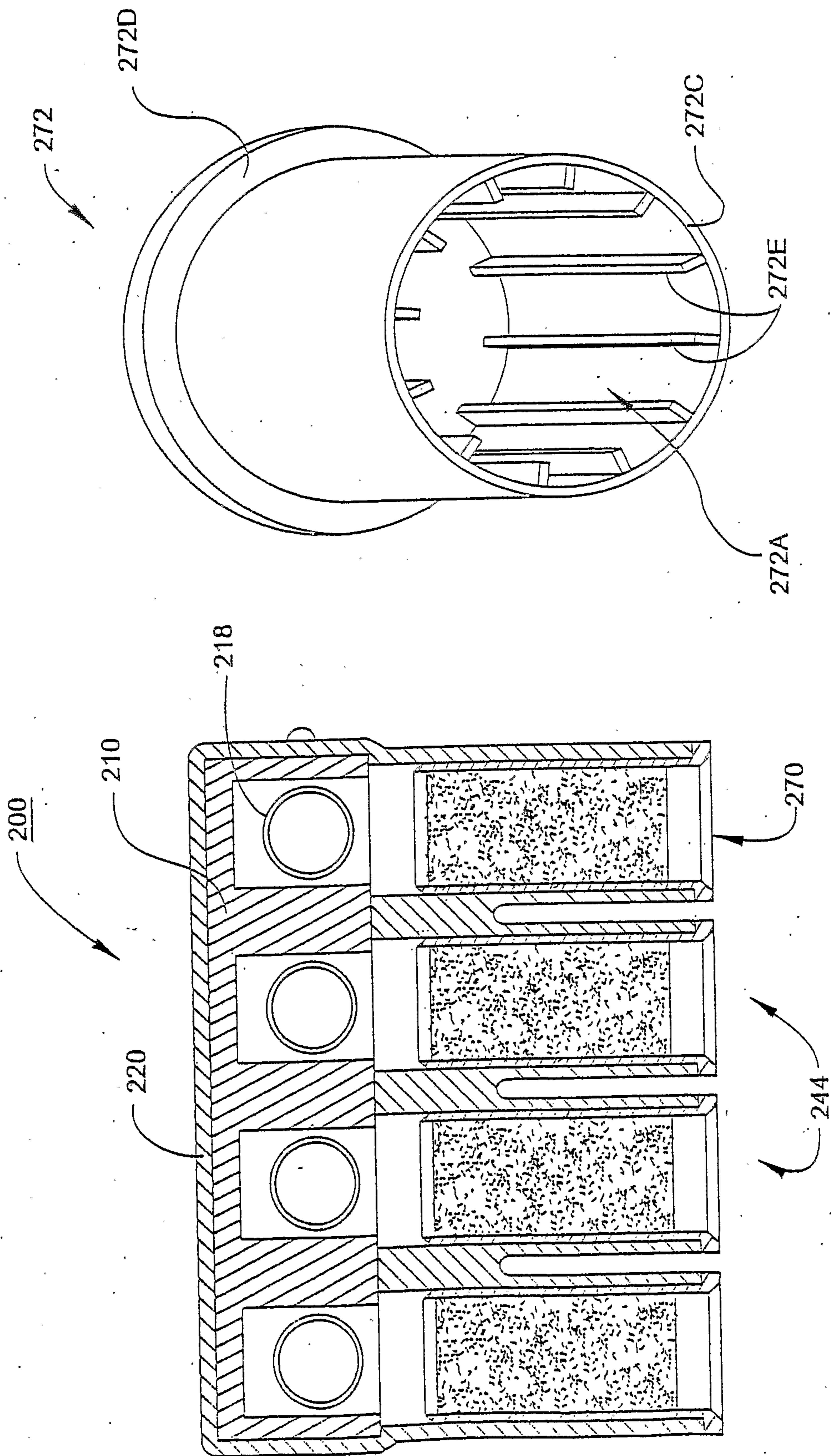

Fig. 7

Fig. 6

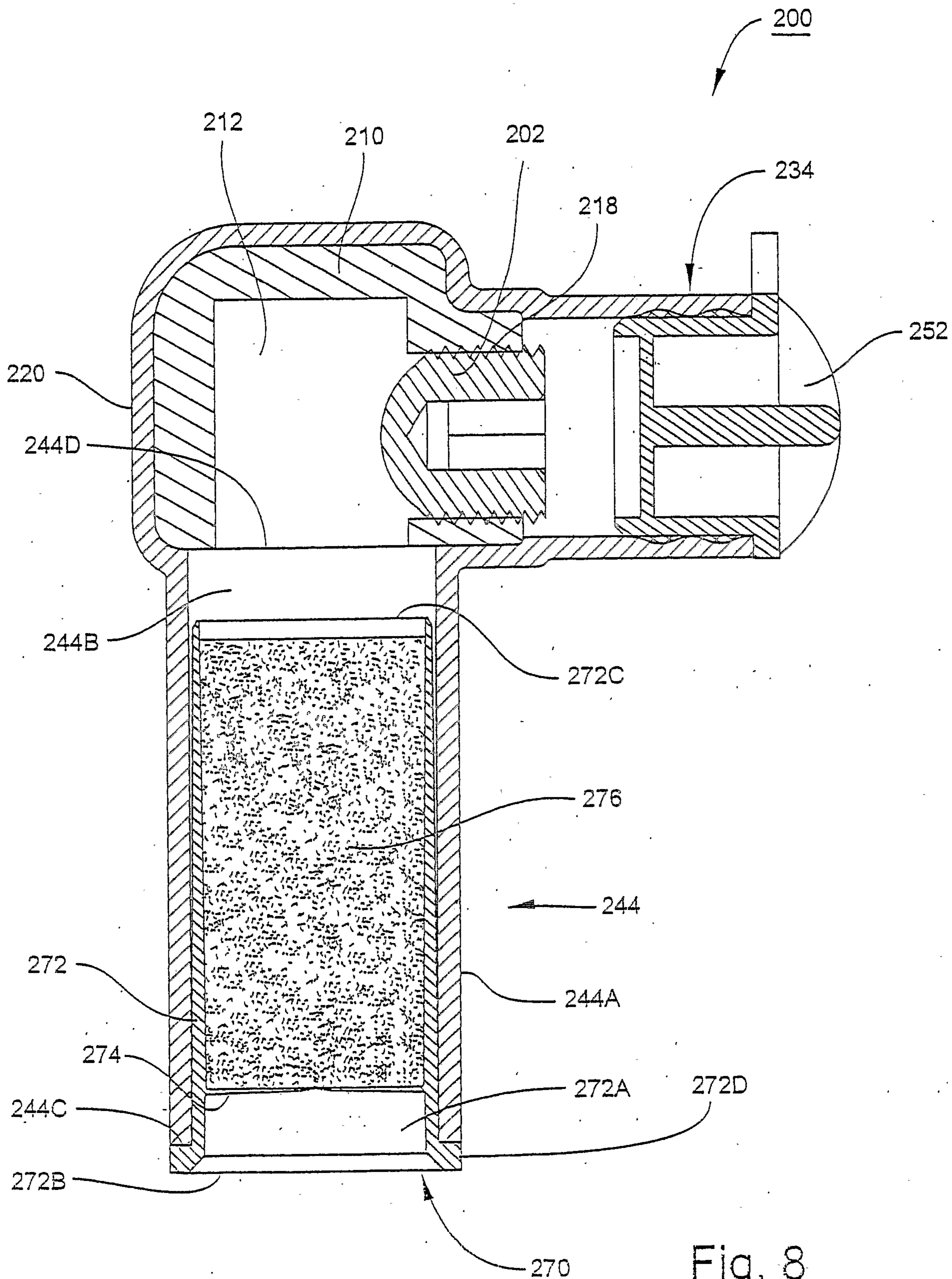
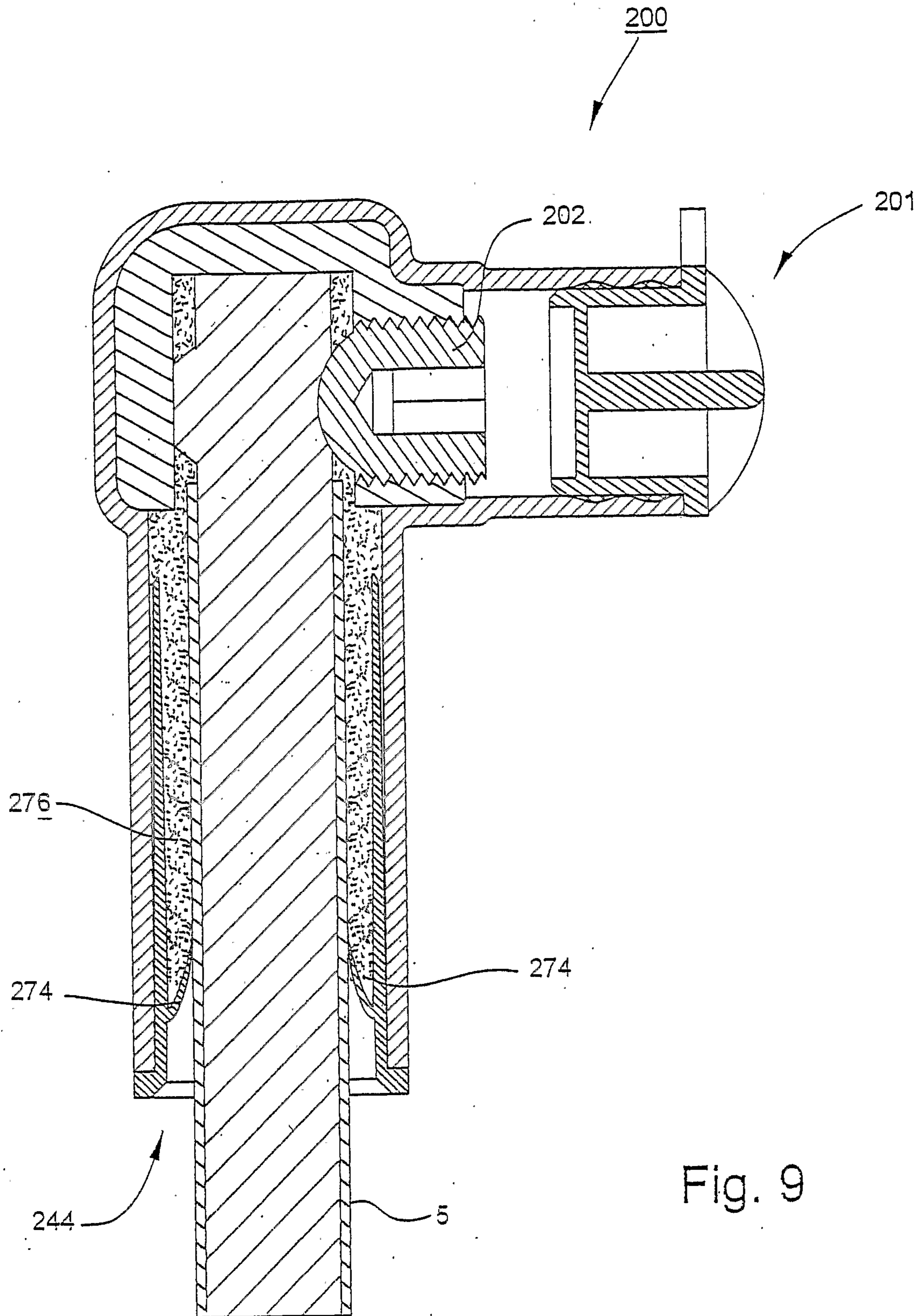
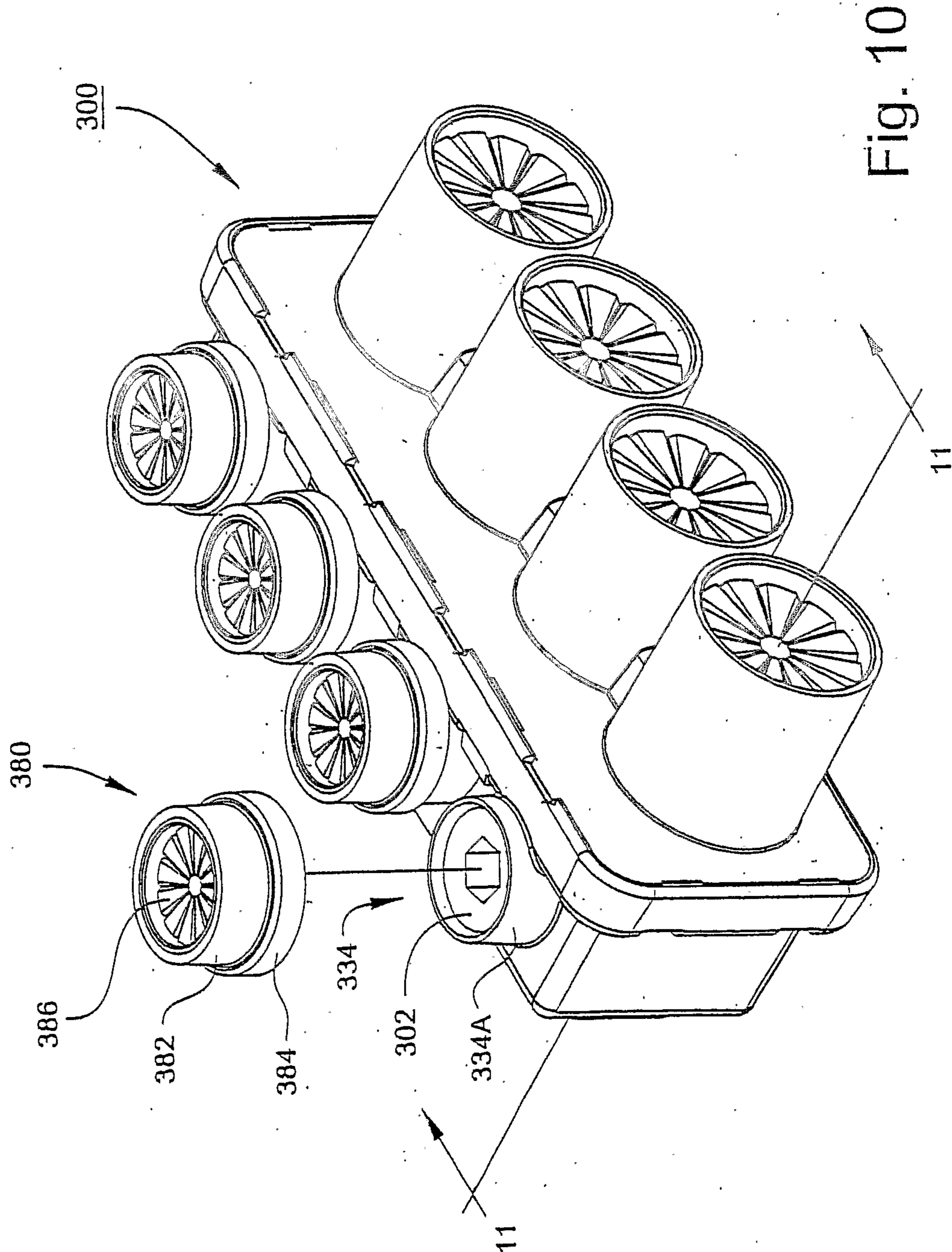

Fig. 8





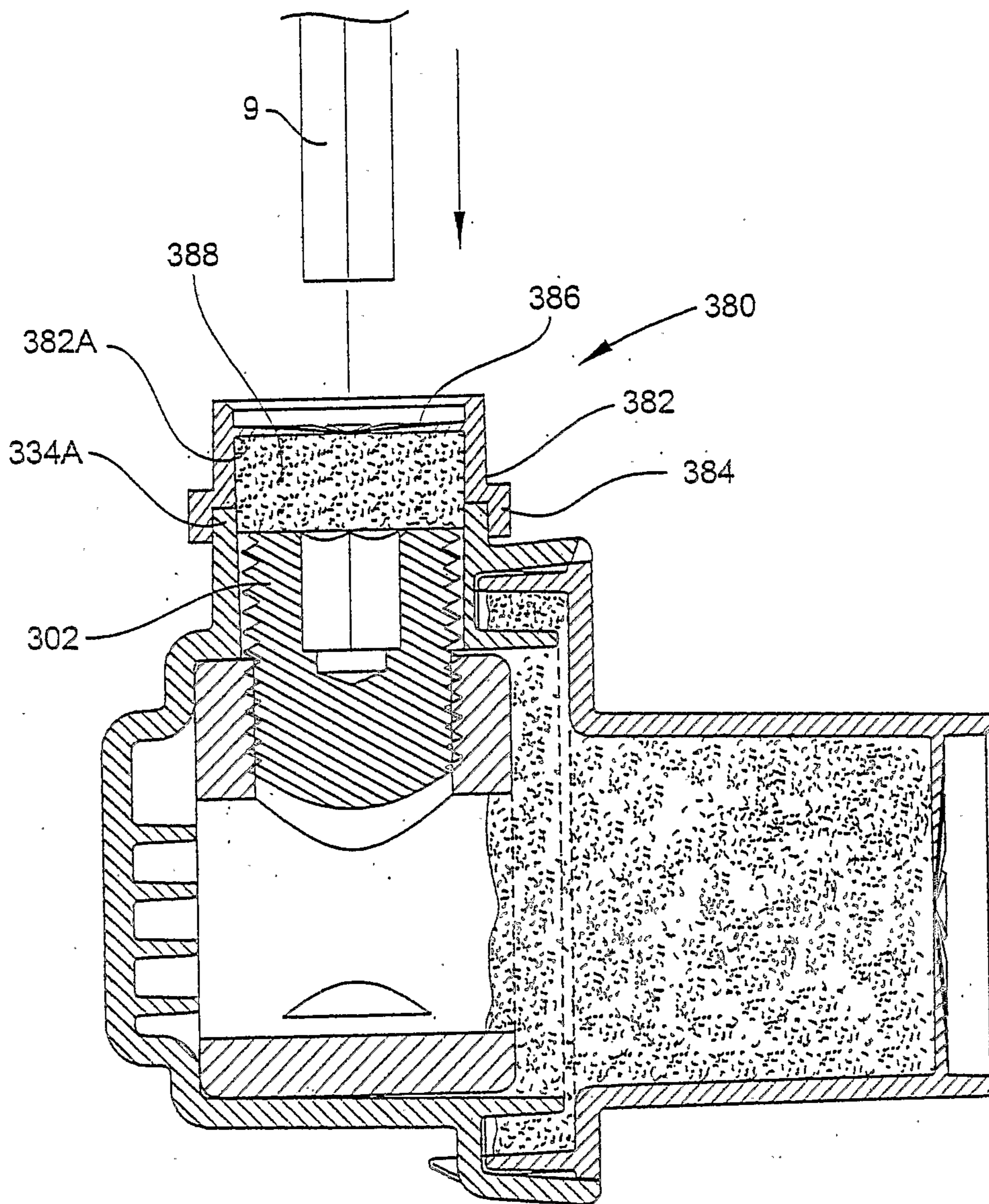

Fig. 11





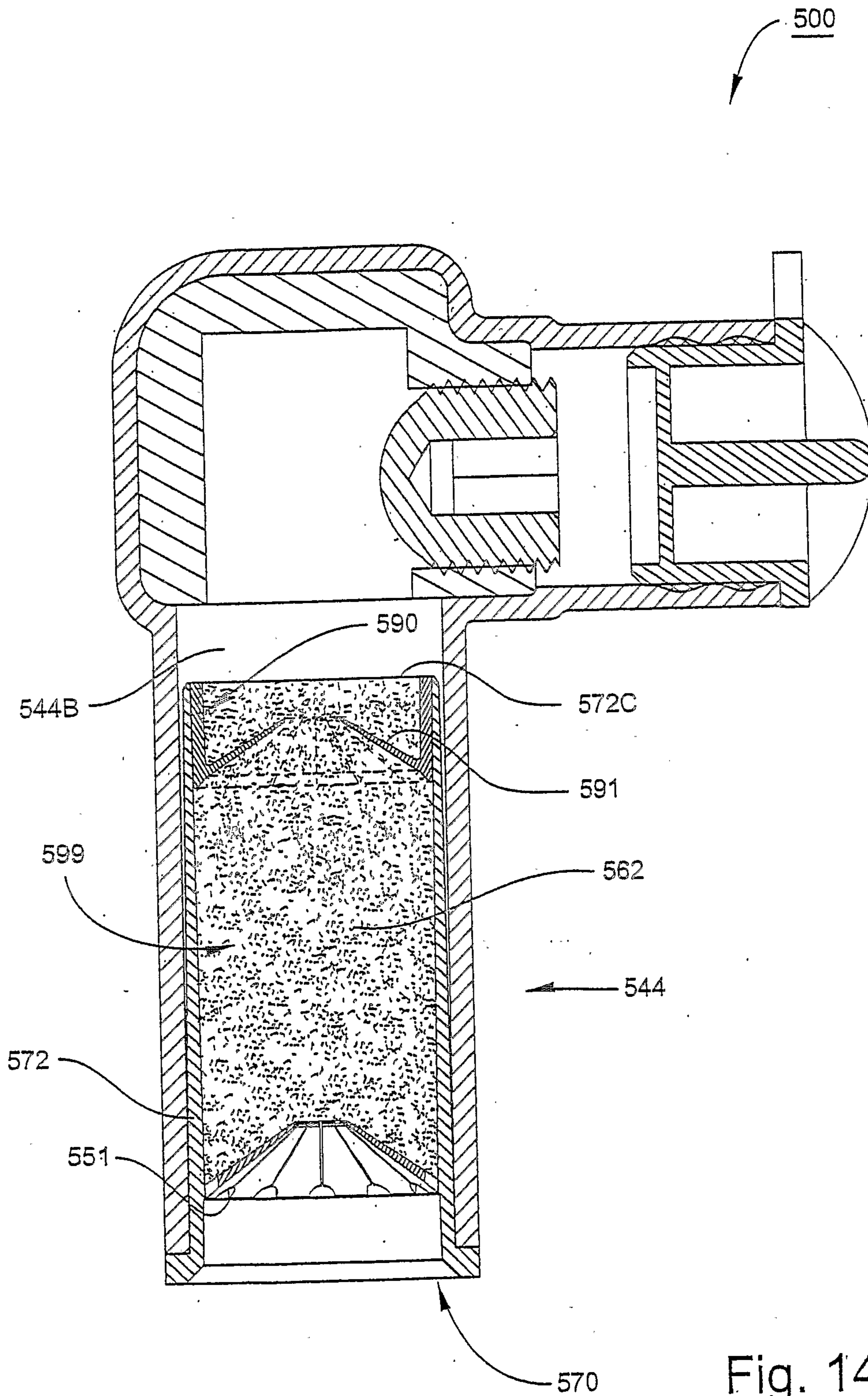

Fig. 14

