

(Model.)

J. K. HARRIS.

BUTTON HOLE ATTACHMENT FOR SEWING MACHINES.

No. 246,765.

Patented Sept. 6, 1881.

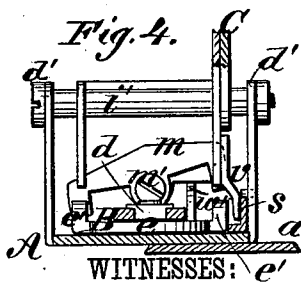
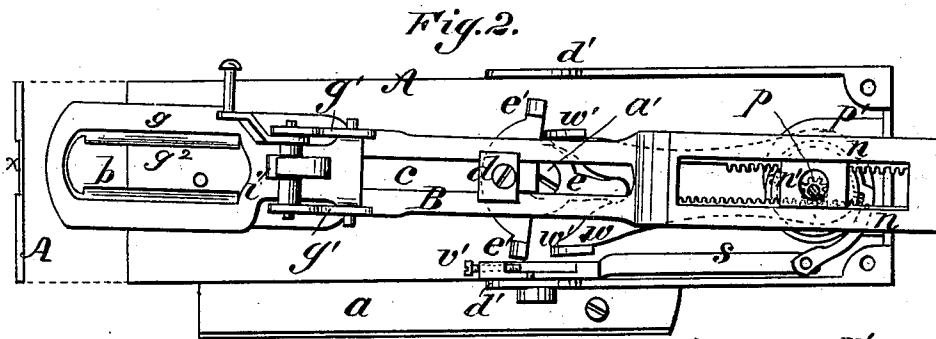
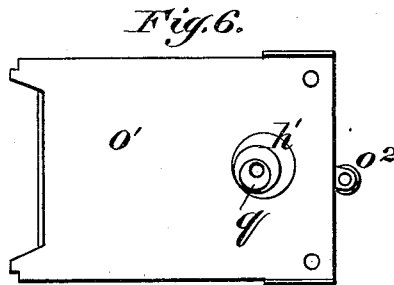
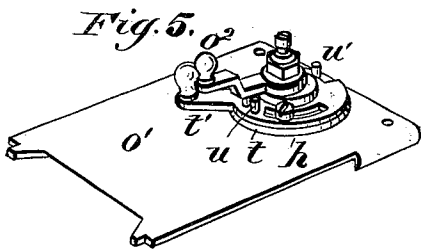
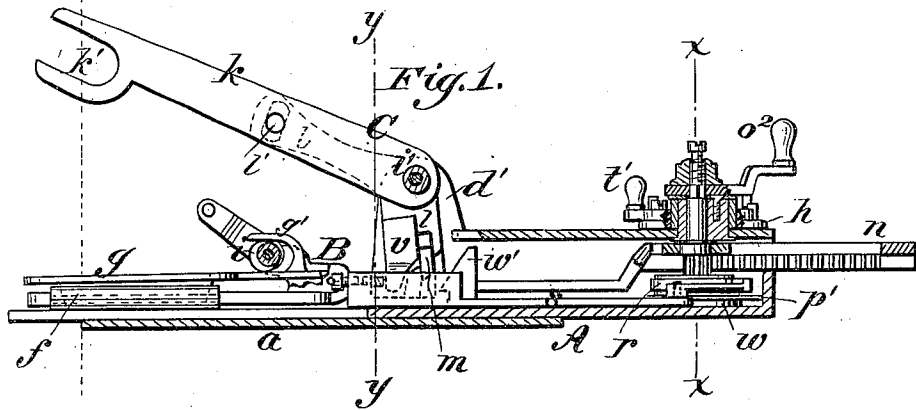

Donn P. Twitchell.
C. Sedgwick

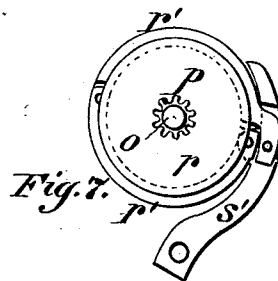
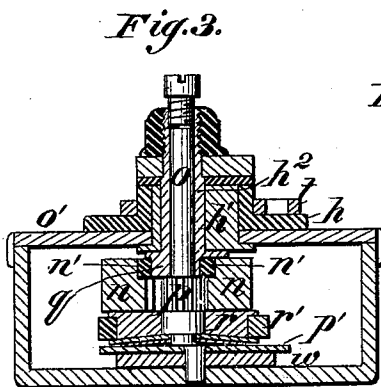

INVENTOR:
J. K. Harris
BY
Mum & Co
ATTORNEYS.

UNITED STATES PATENT OFFICE.

JOHN K. HARRIS, OF SPRINGFIELD, OHIO.

BUTTON-HOLE ATTACHMENT FOR SEWING-MACHINES.

SPECIFICATION forming part of Letters Patent No. 246,765, dated September 6, 1881.

Application filed November 16, 1880. (Model.)

To all whom it may concern:

Be it known that I, JOHN K. HARRIS, of Springfield, in the county of Clarke and State of Ohio, have invented a new and useful Improvement in Button-Hole Attachments for Sewing-Machines, of which the following is a specification.

My improvements relate generally to attachments for sewing-machines for feeding the material with a lateral movement, while at the same time a forward or back feed movement is given, as required in working in button-holes.

The improvement relates specially to the mechanism for reversing the movement of the feed-bar and giving to it a side swing, so that on the return movement the second row of stitches shall be at the required distance from the first row.

In the accompanying drawings, forming part of this specification, Figure 1 is a vertical longitudinal section of my improved button-hole attachment. Fig. 2 is a plan view of the same with the cap-plate removed to show the racks and pinion more clearly. Fig. 3 is a cross-section on line *xx* of Fig. 1. Fig. 4 is a cross-section on line *yy* of Fig. 1. Fig. 5 is a perspective view of the cap-plate and the cranks for shifting the eccentrics. Fig. 6 is a bottom view of the cap-plate, and Fig. 7 represents the clutch for moving the pinion.

Similar letters of reference indicate corresponding parts.

The operative mechanism is carried by a bed-plate, A, shaped to suit the machine with which it is to be used, and formed with a needle-hole or slot at one end and cut away on the under side to allow full play of the feed-bar.

To the bottom of plate A is attached a plate, *a*, the same being a duplicate of the shuttle-race slide used in the "Domestic" and similar sewing-machines, so that the button-hole attachment can be readily attached to the machine by removing the usual shuttle-race slide and inserting the slide *a*, that carries the attachment.

B is the feed-bar, formed with a needle-slot, *b*, at one end, and with a slot, *c*, at or near its mid-length, into which latter slot enters a guide-lug, *d*, that projects upward from and is pivoted to a lever, *e*, hung on plate A by a pin, *a'*. At the side of needle-slot *b*, pads *f*, of india-

rubber or other elastic material, are fitted, which pads, bearing on plate A, form the pressure-surface to hold the goods. Above slot *b* is a slotted plate, *g*, pivoted to lugs *g'* of bar B, and formed with flanges *g''*, that extend through slot *b* at either side to bear on the material.

i is a cam on a shaft hung in lugs *g'*, so that the cam can be turned to bear on plate *g*, and press the flanges *g''* in contact with the material for holding the material smooth. The plate *g* is released by turning the cam-shaft when the material is to be put in place or removed.

In side flanges, *d'*, of plate A a crank-lever, C, is hung by a cross-pin, *i'*. The two arms *k* *l* of lever C are hung separately on the pin *i'*, and connected together by a screw, *l'*, passing through a slot in the outer end of arm *l* into arm *k*, so that the angle between them can be varied for varying the time of feed according to the stroke of the needle and for adjusting the lateral oscillation of the feed-bar. The outer end of arm *k* is slotted, as shown at *k'*, to pass upon the needle set-screw or a projection of the reciprocating needle-bar, and the slot *k'* may, if desired, be formed in a separate piece fitted adjustably on arm *k*.

Upon arm *l* of lever C a rocker, *m*, is hung by a pin, *m'*, as shown most clearly in Fig. 4. The two ends of rocker *m* are bent downward toward lugs *e'*, that project from the ends of lever *e*, which carries the guide *d* of the feed-bar.

The feed-bar B, at its rear end, is formed with parallel racks *n*, above which, in a slot of the feed-bar, is an apertured block, *n'*, Figs. 2 and 3, carried by a cap-plate, *o'*, attached to side flanges of plate A. Upon this cap-plate is fitted a disk, *h*, carrying a cylindrical boss, *h'*, extending through an aperture of the plate, so that the disk may revolve freely, and the boss *h'* is apertured eccentrically to its axis. Through the aperture of the boss *h'* extends a tubular arbor, *h''*, carrying at its upper end a handle, *o''*, above which is a nut that clamps the parts together, while on the lower end of arbor *h''* is an eccentric, *q*, entering the recess of block *n'*. Through the arbor *h''* extends an arbor, *o*, its lower end resting on a step-plate, *p'*, fixed to bed-plate A, to which the arbor is held by a screw tapped into the upper end of

arbor h^2 . The arbor o carries a pinion, p , between the racks n , and below them a clutch-pulley, r .

Around boss h' of disk h is placed a loose ring, t , formed with a handle, t' , and provided with a projecting pin, u , that is in the path of a pin, u' , projecting from handle o^2 . The ring t is formed with a slot, through which a set-screw passes into disk h , so that the ring is adjustably connected thereto, and the disk can be turned by the handle t' to throw the arbor o , block n' , and consequently the pinion and racks, to either side. I use the handle t' for adjusting the ring t simply, and provide the pins u u' , as mentioned, so that by moving handle o^2 both eccentrics shall be moved.

The clutch-pulley r is fitted with a jointed strap, r' , having an arm, s' , pivoted to said strap and jointed to a slide, s , that extends forward beneath a lug, v , projecting from crank-lever C. The slide s is recessed to receive the end of lug v , so that the slide shall be reciprocated by the movement of the crank-lever, and to regulate the movement the slide s is fitted at one end of its recess with a set-screw, v' , which limits the play of the lug in the recess, thereby regulating the feed movement.

Beneath the step-plate p' is pivoted a forked arm, w , having its forward ends extended at opposite sides of lever e and provided with inclined lugs w' , that project upward at opposite sides of the feed-bar B.

The operation is as follows: The vibration of lever C, acting on slide s , gives reciprocation to the slide, which, in turn, acting by the clutching-strap r' , gives intermittent movement to pulley r , arbor o , and pinion p , and the feed-bar B is fed forward or back, according to which rack is engaged by the pinion. As the arm k of lever C rises, the rocker m being turned so that one of its ends shall come in contact with one lug of lever e , the lever is swung on its pivot and turns feed-bar B side-wise on pinion p as a center, so that both forward and side feed is given to the material. The swing of lever e at the same time moves arm w in a direction opposite to movement of bar B, and one lug, w' , is thereby brought behind the depressed end of rocker m , so that as arm l of lever C moves back on the descent of arm k this lug w' will rock lever m and depress its opposite end. Then feed-bar B is swung

back and arm w moved again to rock the lever m to the first position. At the end of the button-hole the forward movement of bar B is arrested by turning the handle o^2 . To move the racks and to bring the pinion p to the center position a stitch or two will then be made, to form the end of the button-hole, and the handle o^2 then moved to engage the other rack, and the operation will proceed with the feed movement reversed.

With some goods the movement of bar B by handle o^2 the distance allowed by the space between the racks is sufficient to separate the two lines of stitches; but when a wider side feed is given, by adjusting crank-lever C, the eccentric boss h^2 is used to shift both the racks and pinion. This is accomplished by adjusting the ring t to bring its pin u into position; then as handle o^2 is turned its pin u' strikes pin u , and thereby the disk h is turned.

The change in direction of feed can be performed without stopping the machine.

The present invention is an improvement upon that heretofore obtained by me and numbered 235,235.

Having thus described my invention, I claim as new and desire to secure by Letters Patent—

1. In button-hole attachments for sewing-machines, the combination, with feed-bar B, having racks n , of the operating-arbor o , carrying pinion p , tubular arbor h^2 , carrying eccentric q , block n' , and eccentric h' , carrying the arbors and fitted for movement in the supporting-plate o' , substantially as and for the purposes set forth.

2. In button-hole attachments, the slotted ring t , provided with pin u , disk h , carrying cam h' , tubular arbor h^2 , carrying cam q , handle o^2 , provided with pin u' , block n' , racks n , arbor o , and pinion p , combined substantially as shown and described, for operation as set forth.

3. In button-hole attachments for sewing-machines, the recessed slide s , having adjusting-screw v' , clutch-pulley r , jointed strap r' , and arm s' , combined with the arbor of the feed-bar and operating-lever C, provided with lug v , substantially as shown and described.

JOHN K. HARRIS.

Witnesses:

A. R. COBAUGH,
J. D. RODGERS.