



- (51) **International Patent Classification:**  
A61M 5/20 (2006.01) A61M 5/48 (2006.01)  
A61M 5/46 (2006.01)
- (21) **International Application Number:**  
PCT/GB2015/051352
- (22) **International Filing Date:**  
8 May 2015 (08.05.2015)
- (25) **Filing Language:** English
- (26) **Publication Language:** English
- (71) **Applicant: CELL THERAPY CATAPULT LIMITED**  
[GB/GB]; 12th Floor Tower Wing B, Guys Hospital, London SE1 9RT (GB).
- (72) **Inventor: SHARPE, Michaela Eileen;** Uplees Lodge, Uplees Road, Oare, Faversham, Kent ME13 0QR (GB).
- (74) **Agent: HANSON, Kevin;** Stratagem Ipm Limited, Meridian Court, Comberton Road, Toft, Cambridge CB23 2RY (GB).
- (81) **Designated States** (unless otherwise indicated, for every kind of national protection available): AE, AG, AL, AM, AO, AT, AU, AZ, BA, BB, BG, BH, BN, BR, BW, BY, BZ, CA, CH, CL, CN, CO, CR, CU, CZ, DE, DK, DM,

DO, DZ, EC, EE, EG, ES, FI, GB, GD, GE, GH, GM, GT, HN, HR, HU, ID, IL, IN, IR, IS, JP, KE, KG, KN, KP, KR, KZ, LA, LC, LK, LR, LS, LU, LY, MA, MD, ME, MG, MK, MN, MW, MX, MY, MZ, NA, NG, NI, NO, NZ, OM, PA, PE, PG, PH, PL, PT, QA, RO, RS, RU, RW, SA, SC, SD, SE, SG, SK, SL, SM, ST, SV, SY, TH, TJ, TM, TN, TR, TT, TZ, UA, UG, US, UZ, VC, VN, ZA, ZM, ZW.

(84) **Designated States** (unless otherwise indicated, for every kind of regional protection available): ARIPO (BW, GH, GM, KE, LR, LS, MW, MZ, NA, RW, SD, SL, ST, SZ, TZ, UG, ZM, ZW), Eurasian (AM, AZ, BY, KG, KZ, RU, TJ, TM), European (AL, AT, BE, BG, CH, CY, CZ, DE, DK, EE, ES, FI, FR, GB, GR, HR, HU, IE, IS, IT, LT, LU, LV, MC, MK, MT, NL, NO, PL, PT, RO, RS, SE, SI, SK, SM, TR), OAPI (BF, BJ, CF, CG, CI, CM, GA, GN, GQ, GW, KM, ML, MR, NE, SN, TD, TG).

**Declarations under Rule 4.17:**

— as to non-prejudicial disclosures or exceptions to lack of novelty (Rule 4.17(v))

**Published:**

— with international search report (Art. 21(3))

(54) **Title:** A SYSTEM FOR ADMINISTERING INJECTIONS

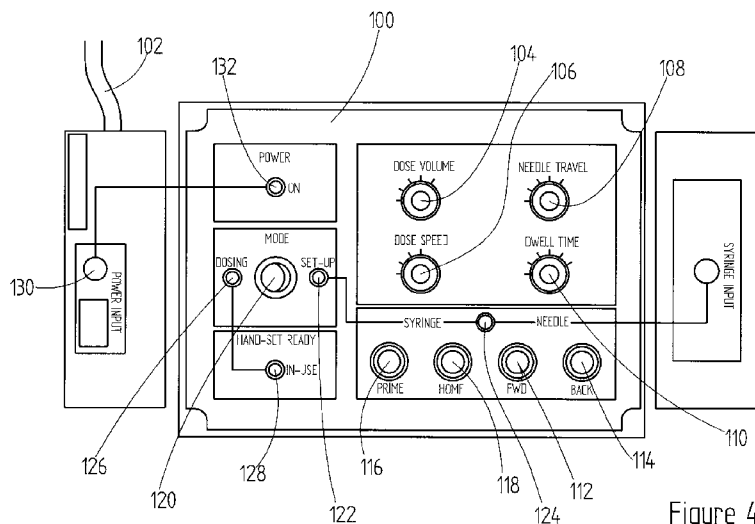

Figure 4

(57) **Abstract:** The present invention provides a system for administering injections, the system comprising: an injection device comprising: a body mounting a needle and a syringe, a first linear actuator and a second linear actuator, wherein the first linear actuator is operable to move the needle between a retracted position and an extended position and the second linear actuator is operable to depress a plunger operably connected to the syringe; and a controller operably connected to the injection device, the controller comprising at least one control operable to change at least one input parameter to the controller selected from needle speed, injection dose volume, needle travel, injection dose speed and dwell time.

WO 2016/181091 A1

**A SYSTEM FOR ADMINISTERING INJECTIONS****FIELD OF THE INVENTION**

5 The present invention relates to a system for administering injections.

**BACKGROUND TO THE INVENTION**

10 The term injections can be used to describe the act of inserting a needle, or other object, into a human or animal subject through the skin, or other surface. Injections in the context of the invention can also mean dosing of a liquid of pre-determined volume into a receptacle. There are many ways in which an injection can be administered. Commonly, injections are administered manually by inserting a needle through the skin of a human or animal and using a syringe connected to the needle in order to provide a vaccine or therapeutic agent, for example. Automated injectors can  
15 also be used for administering injections.

Automatic injectors are used in many different medical applications. One example, US5300029 describes a pistol shaped drug delivery device that mounts a syringe carrying an integral needle on a moveable carriage. An adjustable foot is arranged to set the distance that the needle can be inserted  
20 into a patient. The device includes a linear actuator which, when activated, moves the syringe between a retracted position and an extended condition and depresses a plunger forming part of the syringe to inject the contents of the syringe into the patient. These injectors are generally too painful and damaging to already aggravated skin caused by conditions such as inherited (genetic) and/or autoimmune conditions or trauma from burns etc.

25 Epidermolysis Bullosa is one such condition and is a general term which is used to describe a group of rare inherited skin disorders that cause a person's skin to become fragile and susceptible to blistering and damage. It is estimated that in the UK, 1 in 17,000 people will suffer from Epidermolysis Bullosa. Epidermolysis Bullosa is incurable but the symptoms can be treated to try and  
30 reduce patient discomfort.

Other pistol shaped injection devices are known including that disclosed in US5833661 which describes an injector having a syringe and a needle on separate axes and connected by a flexible conduit or tube. Such a configuration permits the needle to be moved independently of the plunger  
35 of the syringe thus reducing the pain and discomfort caused by an injection device such as that described in US5300029.

US5833661 is a pneumatically controlled injection device meaning that the rate of linear movement of both the needle and the syringe plunger is determined by the pressure of the compressed air  
40 supplied to the injection device. The rate of linear movement of both the needle and syringe plunger will vary in accordance with variations to the pressure of the compressed air supplied to the injection device.

The present invention seeks to provide an improved device for delivering repeatable injections and  
45 dosing.

**SUMMARY OF THE INVENTION**

5 An aspect of the present invention provides a system for administering injections to a patient, the system comprising: an injection device comprising: a body mounting a needle and a syringe, a first linear actuator and a second linear actuator, wherein the first linear actuator is operable to move the needle between a retracted position and an extended position and the second linear actuator is operable to depress a plunger operably connected to the syringe; and a controller operably connected to the injection device, the controller comprising at least one control operable to change  
10 at least one input parameter to the controller selected from injection dose volume, needle travel, needle speed, injection dose speed and dwell time.

15 Independent control of one or more injection parameters permits a single injection device to be used in treating multiple conditions. Many conditions, such as Epidermis Bullosa, require multiple and repeatable injections to be administered to a human body. However, injection parameters for different patients may vary. The present invention enables at least one injection parameter to be changed in order to customise an injection regime for a specific patient. Once the injection parameters have been set, each injection of an injection regime will have the same characteristics.

20 The controller may be separate from the injection device in some embodiments and integral with the injection device in other embodiments.

The controller may comprises respective controls for each input parameter including, but not limited to injection dose volume, needle travel, injection dose speed and dwell time.

25 The needle travel may be configured in the range of zero to twenty millimetres. The injection dose speed may be selected from at least three different speeds. The dose volume may be set between zero and one hundred percent of the syringe contents. The dwell time may be configured in the range of zero to ten seconds. The needle speed may be between zero and ten metres per second.

30 The first linear actuator and the second linear actuator may comprise electric motors.

The needle and the syringe may be mounted in parallel axes.

35 The injection device may comprise a handle connected to the body, wherein the handle comprises operating means to actuate the first linear actuator and the second linear actuator. The operating means may comprise a trigger or button integral with the injection device or an external switch connected physically or wirelessly to the handle.

40 The needle may be around 25mm long.

45 Another aspect of the present invention provides a system for administering injections to a patient, the system comprising: an injection device comprising: a body mounting a needle and a syringe, a first linear actuator and a second linear actuator, wherein the first linear actuator is operable to move the needle between a retracted position and an extended position and the second linear

actuator is operable to depress a plunger operably connected to the syringe; and a controller operably connected to the injection device, the controller comprising a control operable to change the injection device between a set-up mode, wherein the injection device is configured to perform a first set of commands, and a use-mode, wherein the injection device is configured to perform a second set of commands, different to the first.

Providing a set-up mode and an injection mode is advantageous in that the injection device can be prepared for use in a safe manner and without wasting medicament that is to be injected into a human or animal body when in the set-up mode. When in the injection mode, injection parameters are fixed and cannot be changed thus ensuring that each injection an injection regime has the same characteristic.

Another aspect of the present invention provides a method of administering an injection intradermally to a human or animal body, the method comprising: i) preparing a therapeutic agent into a syringe; ii) mounting the syringe into a device according to any of claims 1 to 36; iii) priming a needle connected to the syringe; iv) positioning the device against a patient's skin; v) moving the needle from a retracted position to an extended position, wherein when in the extended condition the needle penetrates intradermally into the patient's skin; vi) delivering a dose of the therapeutic agent into the patient's skin; and, vii) moving the needle from the extended position to the retracted position.

## **FIGURES**

Figure 1 shows an isometric view of an automated drug delivery device according to embodiments of the invention;

Figure 2 shows a side view of the automated drug delivery device of figure 1;

Figure 3 shows a detailed view of a portion of the automated drug delivery device of figures 1 and 2;

Figure 4 shows an illustrative view of a controller according to embodiments of the invention.

## **DETAILED DESCRIPTION**

Referring to figures 1 and 2, an exemplary automated drug delivery device according to the present invention is shown. The drug delivery device 10 includes a body portion 12, a handle portion 14 and a delivery portion 16.

The body portion 12 of the drug delivery device 10 comprises a housing 18 for receiving at least a first linear actuator 20, i.e. an electric motor. The housing 18 is elongate and includes a front end 18a, a rear end 18b, a pair of side walls 18c, a top surface 18e and a bottom surface 18f. An aperture 18d (see figure 3) extends through the pair of side walls 18c of the housing 18 at least partially between the front end 18a and rear end 18b thereof. The aperture 18d is closable by a cover plate 22 on each side of the housing 18 secured to the housing 18 by way of a screw 24 or other fastener. The first linear actuator 20 protrudes through the front end 18a of the housing such that at least a

portion of the first linear actuator 20 is positioned outside of the housing 18. It will be appreciated that in some embodiments the first linear actuator 20 will be positioned wholly within the housing 18. A second linear actuator 30, i.e. an electric motor is also housed within the housing 18. The first linear actuator 20 and second linear actuator 30 are configured to advance the needle 42 and/or syringe plunger 28b at a maximum speed of 60mm/s. The maximum thrust provided by the first linear actuator 20 is twenty Newtons such that the needle 42 is capable of penetrating the skin of a patient but will not snap if driven into a solid surface.

A channel 26 is machined into the top surface 18e of the housing 18 and extends from the front end 18a towards the rear end 18b thereof. A conventional syringe 28 is mountable into the channel 26. The channel 26 is sized to be compatible with a plurality of different capacity syringes, for example one millilitre, two millilitres or five millilitres, but not limited thereto. The syringe 28 comprises a tube 28a, a plunger 28b movable relative to the tube 28a and a dispensing aperture (not shown). When the plunger 28b is depressed into the tube 28a, the contents of the tube 28a are expelled through the dispensing aperture. A pusher 30a connected to the second linear actuator 30 is mounted into the rear end of the channel 26 and is engagable against the plunger 28b of the syringe 28 to depress the plunger 28b of the syringe 28.

A portion of the top surface 18e of the housing 18 is cut away towards the front end 18a of the housing 18 to expose at least a part of the tube 28a of the syringe 28. This configuration facilitates ease of insertion and removal of a syringe 28 from the device 10.

The handle portion 14 of the drug delivery device 10 comprises a grip 32 and a trigger 34. The handle portion 14 is connected directly to the body portion 12 of the device 10. The grip 32 may house a battery (not shown) or may receive an electric cable 36, or both. The grip 32 is hollow and slideably mounts the trigger 34. Electrical wiring from the trigger 34 housed within the grip 32 passes from the handle portion 14 into the body portion 12 of the device through an aperture disposed between the housing portion 14 and the body portion 12 of the device 10. The handle portion 14 of the device 10 is formed from a two part moulding assembled by way of either a snap fit connection or fasteners, or a combination of a snap fit connection and fasteners. In some embodiments, a switch other than a trigger 34 may be provided. In particular, a foot pedal, knee pedal or automated switch may be more convenient for use than a trigger.

The delivery portion 16 of the device 10 comprises a needle support arm 38 extending from the body portion 12. The needle support arm 38 mounts a needle support 40 at an end thereof. The needle support 40 is operable to receive and secure a needle 42. The needle 42 is connected to a conduit 44 which fluidly connects the needle 42 to the syringe 28.

The needle support arm 38 comprises an elongate member 38a having a proximal end 38b attached to the first linear actuator 20 and a distal end 38c mounting the needle support 40. The needle support 40 comprises a body having an aperture therethrough (not shown) for receiving the needle 42. The needle 42 is lockable into the needle support 40 by a locking mechanism forming part of the needle 42 and / or by a clasp forming part of the needle support 40. The clasp is pivotally attached to the needle support and is movable between an open configuration and a closed configuration. When the clasp is in an open configuration, the needle can be removed from or inserted into the needle

support 40. When the clasp is in a closed configuration, the needle 42, when located in the needle support 40, is fixed in position relative to the needle support 40 and cannot be removed.

5 The first linear actuator 20 connects to the elongate member of the needle support arm 38 by a connecting shaft. The connecting shaft comprises a substantially cylindrical body having an aperture at each end. The end of the connecting shaft adjacent the first linear actuator 20 receives at least a part of a drive shaft forming part of the first linear actuator 20. The drive shaft is rotatably fixed relative to the connecting shaft such that when the drive shaft of the first linear actuator 20 rotates, the connecting shaft also rotates. The end of the connecting shaft adjacent the needle support arm 38 comprises an aperture for receiving either a part of the needle support arm 38 or a fastener. The connecting shaft is surrounded by an alignment bush to ensure that the needle support arm 38 remains aligned with the foot 48 when the needle 42 is moved into its extended position.

15 In the illustrated embodiment, the needle 42 is inserted into the aperture through the needle support 40 and secured thereto by a fastener 46 screwing onto a threaded portion of the needle 42 to clamp the needle 42 against the needle support 40. The needle is between 14mm and 50mm long, depending on intended use of the device, and is of 27 or 30 gauge, for example. The needle has a lumen therethrough for delivering the therapeutic agent from the syringe 28 to the patient.

20 In the illustrated embodiment, the housing 18 is connected directly to an external control module 100 by an umbilical cable 102. The external control module 100 is a control box having respective controls 104, 106, 108, 110 for setting each of a plurality of input parameters corresponding to needle travel, needle travel speed, injection dose speed and dwell time, for example. Each control in the illustrated embodiment is an incremental rotary switch but it will be appreciated that any form of control suitable for changing an input parameter could be used.

30 The needle 42 and syringe 28 can be moved manually using the external control module 100. Two buttons 112, 114 are provided on the external control module 100 for moving the needle 42 forwards and backwards. The buttons 112, 114 are configured to activate the first linear actuator 20 in order to drive the needle 42. The button 112 for moving the needle 42 forwards can be configured to drive the needle 42 through its full range of movement from a reference position to a fully extended position. Alternatively, the button 112 can be configured to move the needle 42 forward incrementally. The button 114 for moving the needle 42 backwards can be configured to drive the needle 42 to its reference position. Alternatively, the button 114 can be configured to move the needle 42 backward incrementally.

40 Two buttons 116, 118 are provided on the external control module 100 for moving the syringe pusher 30a forwards and backwards. The buttons are configured to activate the second linear actuator 30 to drive the syringe pusher 30a. The button 116 for moving the syringe pusher 30a forwards can be configured to drive the syringe pusher 30a incrementally in order to prime a syringe 28. Alternatively, the button 116 can be configured to drive the syringe pusher 30a through its full range of movement to expel all liquid content from the syringe 28. The button 118 for moving the syringe pusher 30a backwards can be configured to drive the syringe pusher 30a to its reference position. Alternatively, the button for moving the syringe pusher 30a backwards can be configured to drive the syringe pusher 30a incrementally.

45

The external control module 100 has a rocker switch 120 for switching between set-up mode and dosing mode. When the rocker switch 120 is in the set-up mode position, the first linear actuator 20 is isolated meaning that it cannot be activated. Operation of the buttons 112, 114 configured to move the needle forwards and backwards, or of the trigger 34, would have no effect. The buttons 116, 118 configured to move the syringe pusher 30a forwards and backwards and the controls 104, 106, 108, 110 for setting the input parameters are operable when the external control module 100 is in the set-up mode. Two blue LED's 122, 124 are lit when the rocker switch 120 is in the set-up mode position. When the rocker switch 120 is in the dosing mode position, all buttons and input controls on the external control module 100 are isolated. When the rocker switch 120 is in the dosing mode position, the trigger 34 is operable to activate the first and second linear actuators 20, 30 in order to drive the needle 42 and the syringe pusher 30a in accordance with the input parameters selected when the rocker switch 120 was in the set-up mode position. Two green LED's 126, 128 are lit when the rocker switch 120 is in the dosing mode position.

Embodiments of the external control module 100 can be powered by mains electricity if a power cable is connected between the external control module 100 and a mains power socket. Other embodiments of the external control module 100 can be powered by batteries inserted into a battery compartment within the external control module 100. The external control module 100 is provided with a rocker switch 130 for selectively supplying power thereto. A power cable connected to a mains power supply provides a twenty four volt input which is subsequently converted to five volts by a DC/DC converter. When the rocker switch 130 is in a position corresponding to a power on condition, a green LED 132 is lit.

The controls 104, 106, 108, 110, buttons 112, 114, 116, 118, rocker switches 120, 130, LED's 122, 124, 126, 128, 132, motor step controls, and other electronic components, are connected to a circuit arrangement which receives a five volt input from the DC/DC converter. The circuit arrangement is provided with a processor comprising on-board software for controlling the motor step controls in response to input messages from the controls 104, 106, 108, 110, buttons 112, 114, 116, 118 and trigger 34..

In an alternative embodiment, the injection device 10 is provided with an integral control module having each of the features of the external control module 100 described above.

In use, the needle support arm 38 is movable between a first, retracted position and a second, extended position by the first linear actuator 20. The first linear actuator 20 is activated by a user depressing the trigger 34. The maximum extent of movement between the retracted and extended positions is determined by the type of first linear actuator 20 used in the device 10. For example, if the first linear actuator 20 is an electric motor, the extent of movement between the retracted and extended position is dependent on the maximum possible number of rotations of the electric motor in one direction. In some embodiments the external control module 100 may also comprise an input parameter corresponding to a number of rotations of the electric motor over a pre-determined time period.

Upon movement into the extended position, the needle 42 penetrates a patient at a pre-determined depth. The depth of penetration of the needle 42 is set by a foot 48 which is slideably mounted to

the body portion 12 of the device 10. The illustrated embodiment shows that the position of the foot 48 relative to the body portion 12 of the device 10 fixed.

5 In certain embodiments, the position of the foot 48 relative to the body portion 12 of the device may be adjustable. Adjustability of the position of the foot 48 relative to the body portion 12 of the device 10 can be provided by a fastener which secures the foot 48 to the body portion 12 of the device 10 which, when loosened, permits the foot to be moved manually towards and away from the body portion of the device 12. However, it will be appreciated that the foot 48 could be moved electronically by a further linear actuator, i.e. an electric motor, for example and/or could be  
10 instructed to position itself in accordance with commands sent from the external control module 100. The foot 48 comprises an elongate member 48a having a proximal end 48b mounted to the body portion 12 of the device 10 and a distal end 48c angled to sit against the skin of a patient. The angled portion 48c of the foot 48 comprises a slot 48d through which the needle 42 can protrude when in the extended position. The distance that the needle 42 can protrude through the slot 48d is  
15 dependent on the position of the foot 48 relative to the body portion 12 of the device 10. The foot 48 is secured to the body portion 12 of the device 10 by a fastener 50. When the fastener 50 is tightened, the position of the foot 48 relative to the body portion 12 of the device 10 is fixed. When the fastener 50 is released, the position of the foot 48 relative to the body portion 12 of the device 10 is adjustable by moving the foot 48 longitudinally relative to the body portion 12 of the device 10.

20 The angle of insertion of the needle 42 into the patient can be varied by varying the angle of the distal end 48c of the foot 48. In the illustrated embodiment, the angle of the foot can be varied by replacing the foot with one having a distal end 48c of different angle. The angle of insertion of the needle 42 into the patient will be selected from any angle between  $0^{\circ}$  and  $90^{\circ}$ . The foot 48 is formed  
25 from a sterilisable material such as stainless steel. In the illustrated embodiment the foot 48 is intended to be re-used but it will be appreciated that in certain embodiments the foot 48 could be disposable and made from a single use material such as a plastic.

30 The penetration of the needle 42 into a patient is also dependent on the angle of the distal end 48c of the foot 48. For example, if the angle of the distal end 48c of the foot 48 is  $90^{\circ}$ , the permitted travel of the needle support arm 38 would be less than if the angle of the distal end 48c of the foot 48 is  $22.5^{\circ}$ .

35 Before use of the device 10, the needle is required to be aligned into a zero position to set the depth of insertion of the needle 42 into the patient. The zero position is set by moving the needle 42 into its extended position before aligning the distal end 48c of the foot 48 to the tip 42a of the needle 42. This operation is performed by putting the external control module 100 into set-up mode by using the rocker switch 120. The needle 42 is advanced by operation of the button 112 configured to  
40 activate the first linear actuator 20 to move the needle 42 forwards in order to fully extend the needle 42. The button 114 configured to activate the first linear actuator 20 to move the needle 42 backwards is then operated in order to align the tip of the needle 42 with the distal end of the foot 48c. This position, when the external control module 100 is put into dosing mode will be the zero position that the tip of the needle 42 returns to after the device 10 has been operated for each individual injection. To assist an operator in setting the zero position, the proximal end 48b of the  
45 foot 48 is provided with a scale which is alignable with the needle support arm 38. In normal

operation, the needles 42 retracted position will be such that it does not extend beyond the end of the foot 48. The needles 42 extended position will be variable depending on the type of injection required, i.e. intradermal, subcutaneously, intramuscularly or intraocular, for example.

5 The needle 42 is movable independently of the plunger 28b of the syringe 28. Referring to figure 3, the body 12 of the device 10 also houses the second linear actuator 30. The second linear actuator 30 is connected to the pusher 30a via a threaded connection therebetween. When the second linear actuator 30 is activated, the pusher 30a is moved forward along the channel 26 by a drive shaft forming part of the second linear actuator 30 consequently pushing the plunger 28b into the tube  
10 28a of the syringe 28 and expelling the contents of the tube 28a into the conduit 44 to the needle 42.

When the trigger 34 is depressed by a user, the first linear actuator 20 is activated to move the  
15 needle support arm 38, and thus the needle 42, from the retracted position to the extended position. The second linear actuator 30 is then actuated to depress the plunger 28b of the syringe 28 into the tube 28a of the syringe 28 in order to inject its contents into a patient. When the plunger 28b of the syringe 28 has been fully depressed there is a delay, or dwell, of between one to ten seconds before the first linear actuator 20 moves the needle support arm 38, and thus the needle  
20 42, from the extended position to the retracted position and the second linear actuator 30 moves the pusher 30a towards the rear 18b of the housing 18.

The device 10 is provided with a lock (not shown) which, when active, prevents actuation of the first and second linear actuators when the trigger 34 is depressed by a user. One example of such a lock comprises a key based lock which requires releasing before the device can be used. The first and  
25 second linear actuators 20, 30 also will not operate when the external control module 100 is switched off.

Prior to use, the syringe 28 is filled with a therapeutic agent and inserted into the channel 26 in the top surface of the body portion 12 of the device 10. The needle 42 is then inserted into the needle  
30 support 38 before the flexible tube 44, or conduit, is attached to both the needle 42 and the syringe 28. The needle 42 is primed by depressing the plunger 28b of the syringe 28 to the extent necessary to fill the needle 42 with the therapeutic agent. This process is undertaken with the external control module 100 in set-up mode. The button 116 corresponding to moving the syringe pusher 30a forward is operated to activate the second linear actuator 30 and drive the syringe pusher 30a  
35 forwards until all air has been expelled from the syringe 28. This process is repeated each time a new syringe 28 is loaded into the device 10.

After each injection or series of injections, the needle 42 is removed and replaced with a new needle  
40 42. The syringe 28 can hold multiple doses of therapeutic agent and is removed and replaced once empty. Used needles 42 and syringes 28 are segregated and sent for incineration.

A particular example of a therapeutic agent suitable for use with the device 10 is a suspension of human dermal fibroblasts (HDFs) in cell storage medium, for injection into the skin. It will however be appreciated that the device 10 can be used with any suitable cell or drug based therapeutic  
45 agent, for example stem cells, differentiated cells, modified cells; including genetically modified cells

and/or any suitable pharmaceutically active agents. The cells may be autologous or heterologous. The cells or drug-based therapeutic agent may further comprise a pharmaceutical carrier or excipient, such as cell-storage medium. In addition, the device 10 is suitable for use in administering biologicals and biomedical products including, but not limited to, vaccines, genetic materials and biosimilars, for example.

The foregoing description describes use of the device 10 for administering intradermal injections to an animal or human body. The device 10 can be used in the therapeutic, cosmetic, veterinary, industrial and manufacturing markets. This device 10 is also suitable for administering subcutaneous, intraocular and intramuscular injections and for delivering cell therapies, vaccines, gene modified cells, derma fillers, hair loss therapies and botox as well as therapeutic agents to fluid bags, dosing and other similar uses.

The invention also provides a method of administering an injection, the method comprising: i) preparing a therapeutic agent into a syringe 28; ii) mounting the syringe into an injection device 10; iii) priming a needle 42 connected to the syringe 28; iv) positioning the injection device 10 against a target; v) moving the needle 42 from a retracted position to an extended position, wherein when in the extended condition the needle 42 penetrates the target; vi) delivering a dose of the therapeutic agent into the target; and, vii) moving the needle 42 from the extended position to the retracted position.

**Claims**

1. A system for administering injections, the system comprising:  
An injection device comprising: a body mounting a needle and a syringe, a first linear actuator and a second linear actuator, wherein the first linear actuator is operable to move the needle between a retracted position and an extended position and the second linear actuator is operable to depress a plunger operably connected to the syringe; and  
A controller operably connected to the injection device, the controller comprising at least one control operable to change at least one input parameter to the controller selected from needle speed, injection dose volume, needle travel, injection dose speed and dwell time.
2. A system for administering injections according to claim 1, wherein the controller is separate from the injection device.
3. A system for administering injections according to claim 1, wherein the controller is integral with the injection device.
4. A system for administering injections according to any of claims 1 to 3, wherein the controller comprises respective controls for each input parameter.
5. A system for administering injections according to any preceding claim, wherein the controller is configured to enable the needle travel to be set in the range of zero to twenty millimetres.
6. A system for administering injections according to any preceding claim, wherein the controller is configured to enable the injection dose speed to be selected from at least three different speeds.
7. A system for administering injections according to any preceding claim wherein the controller is configured to enable the dose volume to be set between zero and one hundred percent of the syringe contents.
8. A system for administering injections according to any preceding claim wherein the controller is configured to enable the dwell time to be set in the range of zero to ten seconds.
9. A system for administering injections according to any preceding claim, wherein the first linear actuator and the second linear actuator are electric motors.
10. A system for administering injections according to any preceding claim wherein the needle and syringe are mounted in parallel axes.
11. A system for administering injections according to any preceding claim further comprising a handle, wherein the handle comprises operating means to actuate the first linear actuator and the second linear actuator.
12. A system for administering injections according to claim 11, wherein said operating means comprises a trigger or button.

13. A system for administering injections according to claim 12, wherein said operating means comprise an external switch connected physically or wirelessly to the handle.
14. A system for administering injections according to any preceding claim further comprising a foot for setting the distance the needle can insert into a patient.
- 5 15. A system for administering injections according to claim 14 wherein the foot is disposable after use.
16. A system for administering injections according to any preceding claim wherein the first linear actuator and second linear actuator are housed at least partially within a body.
17. A system for administering injections according to any preceding claim wherein the second linear actuator comprises a pusher engageable with the plunger of the syringe.
- 10 18. A system for administering injections according to claim 17, wherein the pusher is slideably mounted within a channel in the body of the device.
19. A system for administering injections according to claim 18, wherein the syringe is mounted in the channel in the body of the device.
- 15 20. A system for administering injections according to claim 16, wherein the body comprises a removable access panel covering a recess within which the first linear actuator and second linear actuator are at least partially housed.
21. A system for administering injections according to any preceding claim, wherein the needle and syringe are connected by a flexible conduit.
- 20 22. A system for administering injections according to any preceding claim, wherein the needle is between 14mm to 50mm long, preferably the needle is 25mm long.
23. A system for administering injections according to any preceding claim, wherein the device is for use in administering cell therapies, vaccines, gene modified cells, derma fillers, hair loss therapies, botox and embedding cells on biological scaffolds.
- 25 24. A system for administering injections according to claim 23, wherein skin conditions includes epidermolysis bullosa.
25. A system for administering injections for administering as described with reference to, and / or as shown in, the drawings.
26. A system for administering injections, the system comprising:
- 30 an injection device comprising: a body mounting a needle and a syringe, a first linear actuator and a second linear actuator, wherein the first linear actuator is operable to move the needle between a retracted position and an extended position and the second linear actuator is operable to depress a plunger operably connected to the syringe; and
- a controller operably connected to the injection device, the controller comprising a control operable to change the injection device between a set-up mode, wherein the injection device
- 35

- is configured to perform a first set of commands, and a use-mode, wherein the injection device is configured to perform a second set of commands, different to the first.
27. A system for administering injections wherein the controller further comprises at least one control operable to change at least one input parameter to the controller selected from injection dose volume, needle travel, injection dose speed and dwell time.
28. A system for administering injections wherein the first set of commands comprise movement of the plunger and adjustment of one or more of injection dose volume, needle travel, injection dose speed and dwell time and wherein the second set of commands comprise movement of the needle into the extended position, movement of the plunger to deliver a medicament to the needle and movement of the needle to the retracted position.
29. A system for administering injections according to claim 27, wherein the controller is separate from the injection device.
30. A system for administering injections according to claim 27, wherein the controller is integral with the injection device.
31. A system for administering injections according to any of claims 27 to 29, wherein the controller comprises respective controls for each of injection dose volume, needle travel, injection dose speed and dwell time
32. A system for administering injections according to any of claims 27 to 30, wherein the controller is configured to enable the needle travel to be set in the range of zero to twenty millimetres.
33. A system for administering injections according to any of claims 27 to 31, wherein the controller is configured to enable the injection dose speed to be selected from at least three different speeds.
34. A system for administering injections according to any of claims 27 to 32 wherein the controller is configured to enable the dose volume to be set between zero and one hundred percent of the syringe contents.
35. A system for administering injections according to any of claims 27 to 33, wherein the controller is configured to enable the dwell time to be set in the range of zero to ten seconds.
36. A system for administering injections according to any of claims 27 to 34, wherein the first linear actuator and the second linear actuator are electric motors.
37. A system for administering injections according to any of claims 27 to 35, wherein the needle and syringe are mounted in parallel axes.
38. A method of administering one or more injections, the method comprising:
- i) preparing a therapeutic agent into a syringe ;
  - ii) mounting the syringe into a system according to any of claims 1 to 36;
  - iii) priming a needle fluidly connected to the syringe and mounted in the injection device ;

- iv) positioning the injection device against a target;
- v) moving the needle from the retracted position to the extended position, wherein when in the extended condition the needle penetrates into the target;
- vi) delivering a dose of the therapeutic agent into the target;
- 5 vii) moving the needle from the extended position to the retracted position; and
- viii) repeating steps i) to vii) for multiple injections.

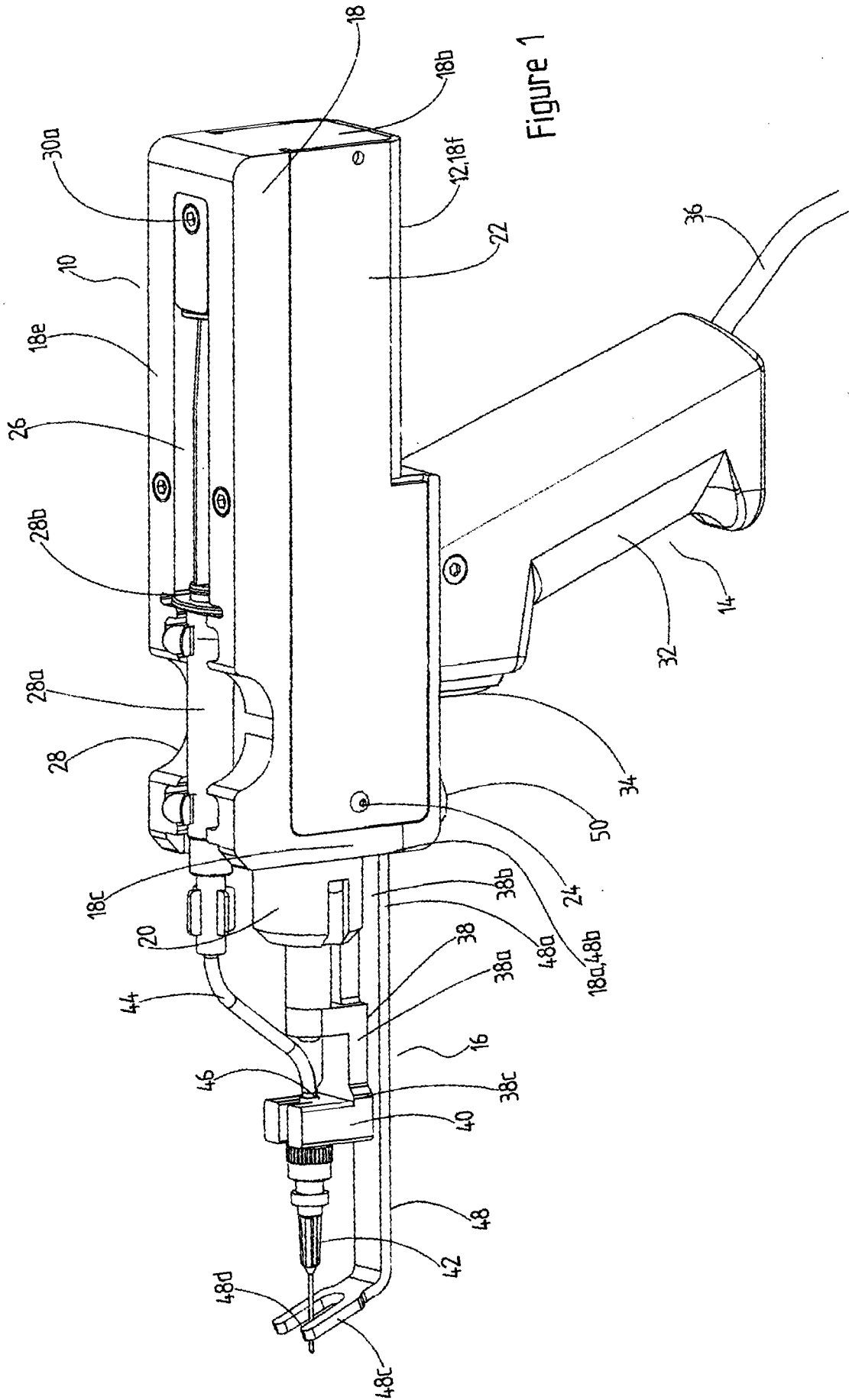

Figure 1

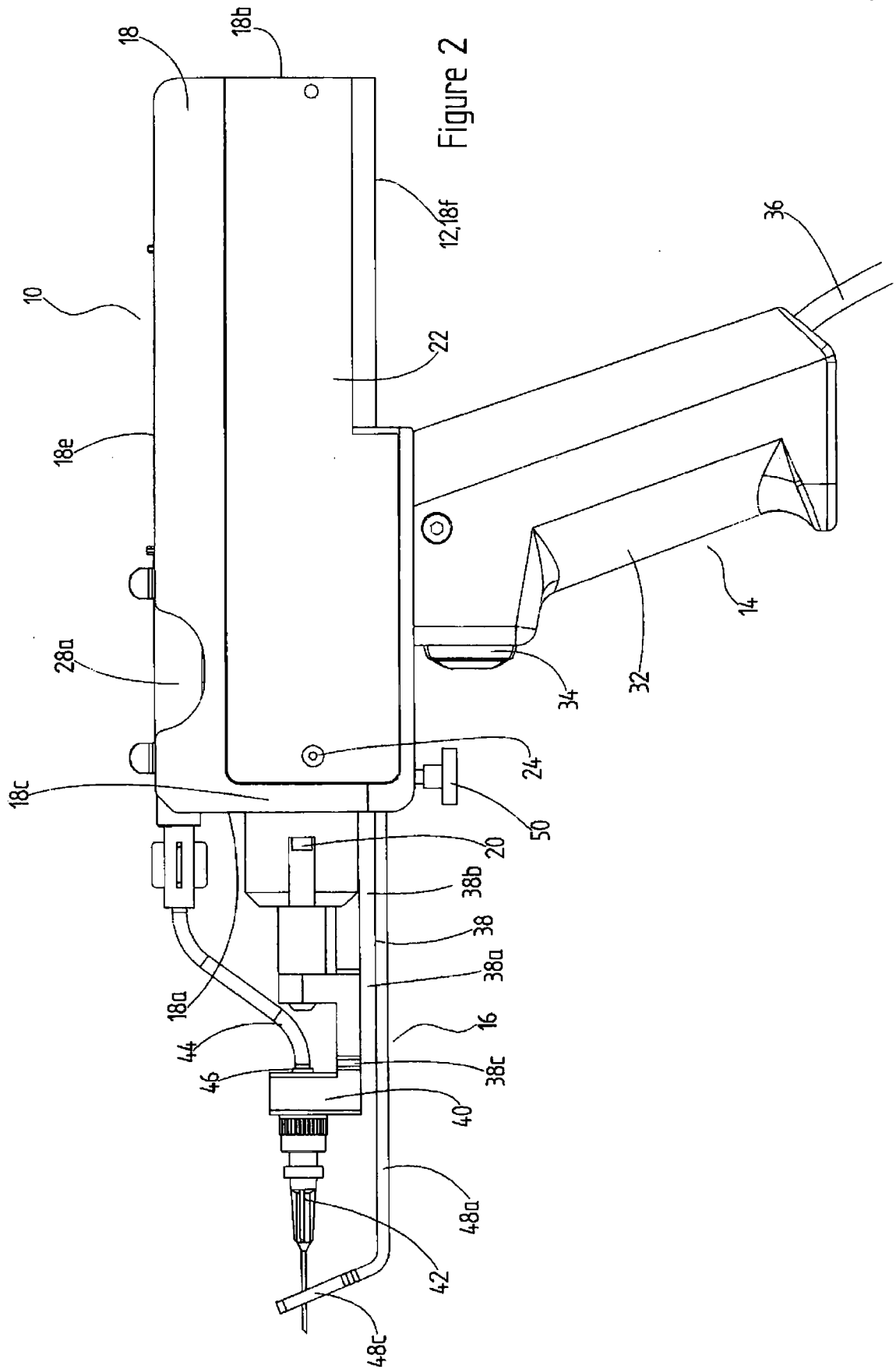

Figure 2

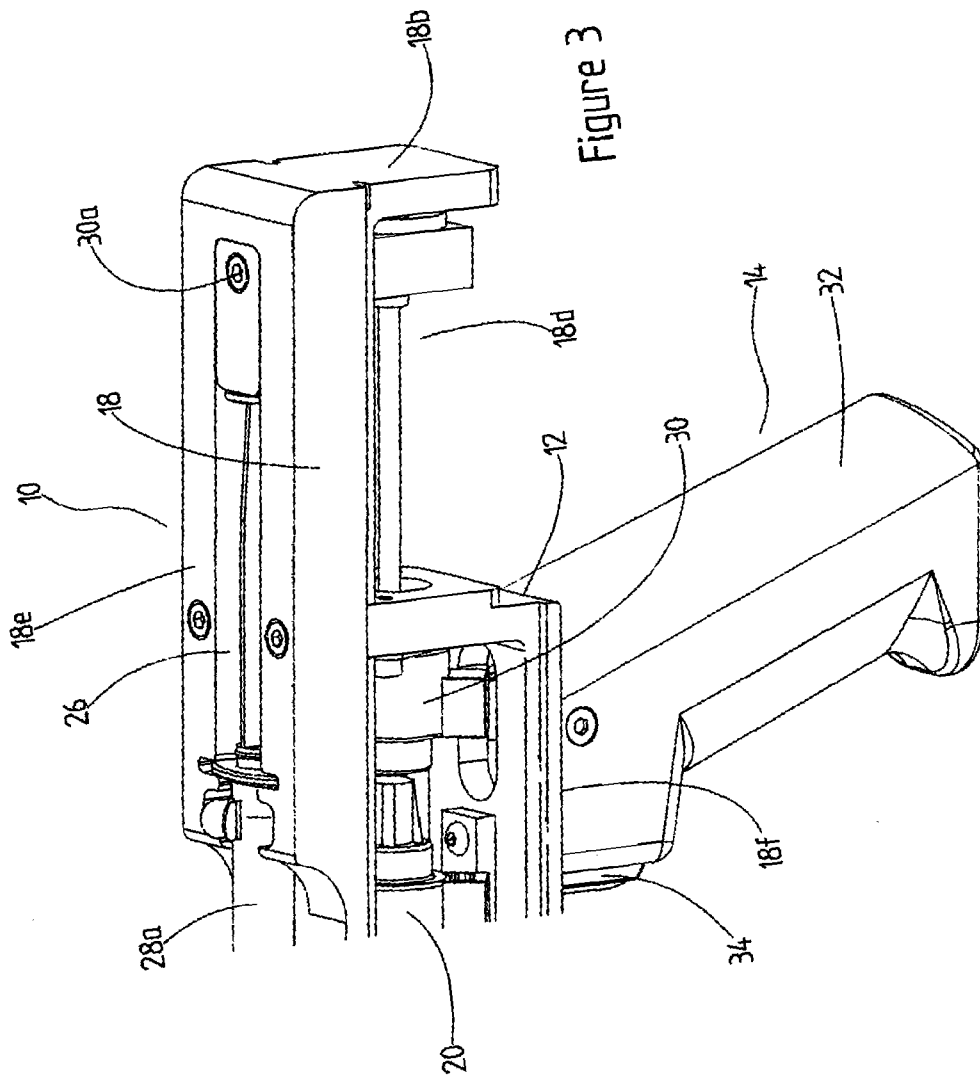

Figure 3

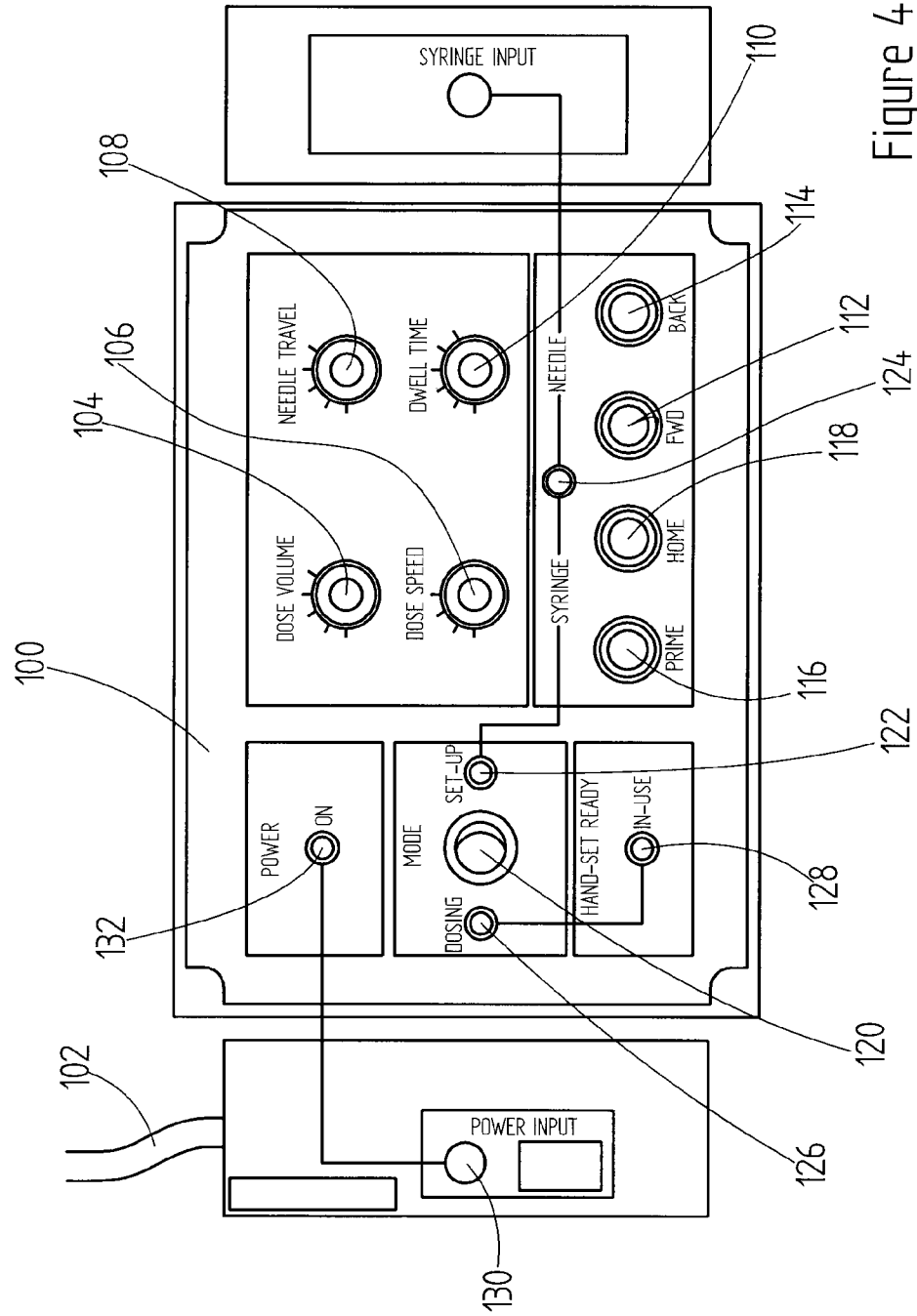

Figure 4

# INTERNATIONAL SEARCH REPORT

International application No  
PCT/GB2015/051352

<b>A. CLASSIFICATION OF SUBJECT MATTER</b> INV. A61M5/20                  A61M5/46                  A61M5/48 ADD.		
According to International Patent Classification (IPC) or to both national classification and IPC		
<b>B. FIELDS SEARCHED</b>		
Minimum documentation searched (classification system followed by classification symbols) A61M		
Documentation searched other than minimum documentation to the extent that such documents are included in the fields searched		
Electronic data base consulted during the international search (name of data base and, where practicable, search terms used) EPO-Internal		
<b>C. DOCUMENTS CONSIDERED TO BE RELEVANT</b>		
Category*	Citation of document, with indication, where appropriate, of the relevant passages	Relevant to claim No.
X	FR 2 622 457 A1 (PICCINALI ERIC [FR]) 5 May 1989 (1989-05-05)	1-3, 9-20, 22-30, 36,37
Y	page 4, line 8 - line 23	4-8,21, 31-35
Y	----- EP 2 689 793 A1 (JUVAPLUS SA [CH]) 29 January 2014 (2014-01-29) paragraph [0074]; figure 5B	4-8, 31-35
Y	----- US 2005/261633 A1 (KHALAJ BEN M [US]) 24 November 2005 (2005-11-24) figure 5	4,31
Y	----- KR 101 007 105 B1 (KNU INDUSTRY COOPERATION FOUND [KR]) 10 January 2011 (2011-01-10) figure 2 -----	21
<input type="checkbox"/> Further documents are listed in the continuation of Box C. <input checked="" type="checkbox"/> See patent family annex.		
* Special categories of cited documents :		
"A" document defining the general state of the art which is not considered to be of particular relevance	"T" later document published after the international filing date or priority date and not in conflict with the application but cited to understand the principle or theory underlying the invention	
"E" earlier application or patent but published on or after the international filing date	"X" document of particular relevance; the claimed invention cannot be considered novel or cannot be considered to involve an inventive step when the document is taken alone	
"L" document which may throw doubts on priority claim(s) or which is cited to establish the publication date of another citation or other special reason (as specified)	"Y" document of particular relevance; the claimed invention cannot be considered to involve an inventive step when the document is combined with one or more other such documents, such combination being obvious to a person skilled in the art	
"O" document referring to an oral disclosure, use, exhibition or other means	"&" document member of the same patent family	
"P" document published prior to the international filing date but later than the priority date claimed		
Date of the actual completion of the international search	Date of mailing of the international search report	
3 February 2016	11/02/2016	
Name and mailing address of the ISA/ European Patent Office, P.B. 5818 Patentlaan 2 NL - 2280 HV Rijswijk Tel. (+31-70) 340-2040, Fax: (+31-70) 340-3016	Authorized officer  Daintith, Nichola	

# INTERNATIONAL SEARCH REPORT

International application No.  
PCT/GB2015/051352

## Box No. II Observations where certain claims were found unsearchable (Continuation of item 2 of first sheet)

This international search report has not been established in respect of certain claims under Article 17(2)(a) for the following reasons:

1.  Claims Nos.: 38  
because they relate to subject matter not required to be searched by this Authority, namely:  

A meaningful search is not possible on the basis of claim 38 because this is directed to a method for treatment of the human or animal body by therapy, Rule 39.1(iv) PCT.
2.  Claims Nos.:  
because they relate to parts of the international application that do not comply with the prescribed requirements to such an extent that no meaningful international search can be carried out, specifically:
3.  Claims Nos.:  
because they are dependent claims and are not drafted in accordance with the second and third sentences of Rule 6.4(a).

## Box No. III Observations where unity of invention is lacking (Continuation of item 3 of first sheet)

This International Searching Authority found multiple inventions in this international application, as follows:

1.  As all required additional search fees were timely paid by the applicant, this international search report covers all searchable claims.
2.  As all searchable claims could be searched without effort justifying an additional fees, this Authority did not invite payment of additional fees.
3.  As only some of the required additional search fees were timely paid by the applicant, this international search report covers only those claims for which fees were paid, specifically claims Nos.:
4.  No required additional search fees were timely paid by the applicant. Consequently, this international search report is restricted to the invention first mentioned in the claims; it is covered by claims Nos.:

### Remark on Protest

- The additional search fees were accompanied by the applicant's protest and, where applicable, the payment of a protest fee.
- The additional search fees were accompanied by the applicant's protest but the applicable protest fee was not paid within the time limit specified in the invitation.
- No protest accompanied the payment of additional search fees.

# INTERNATIONAL SEARCH REPORT

Information on patent family members

International application No

PCT/GB2015/051352

Patent document cited in search report	Publication date	Patent family member(s)	Publication date
FR 2622457	A1	05-05-1989	NONE
-----			
EP 2689793	A1	29-01-2014	EP 2689793 A1 29-01-2014
			US 2014039405 A1 06-02-2014
-----			
US 2005261633	A1	24-11-2005	NONE
-----			
KR 101007105	B1	10-01-2011	NONE
-----			