

(19)



Europäisches Patentamt  
European Patent Office  
Office européen des brevets



(11)

**EP 0 601 252 B1**

(12)

**EUROPEAN PATENT SPECIFICATION**

(45) Date of publication and mention  
of the grant of the patent:  
**29.04.1998 Bulletin 1998/18**

(51) Int Cl.<sup>6</sup>: **C21D 9/56**

(21) Application number: **92403373.1**

(22) Date of filing: **11.12.1992**

(54) **Hearth roller with suppressed heat crown**

Herdrolle mit unterdrückter thermischer Balligkeit

Rouleau de foyer à bombement thermique supprimé

(84) Designated Contracting States:  
**DE FR GB**

(43) Date of publication of application:  
**15.06.1994 Bulletin 1994/24**

(73) Proprietor: **SUMITOMO METAL INDUSTRIES,  
LTD.**  
**Osaka-shi, Osaka-fu 540 (JP)**

(72) Inventor: **Isaka, Kazumi**  
**Amagasaki-shi, Hyogo-ken (JP)**

(74) Representative: **Schrimpf, Robert**  
**Cabinet Regimbeau**  
**26, Avenue Kléber**  
**75116 Paris (FR)**

(56) References cited:

- **PATENT ABSTRACTS OF JAPAN vol. 16, no. 249 (C-948)8 June 1992 & JP-A-40 56 733 (SUMITOMO METAL INDUSTRIES) 24 February 1992**
- **PATENT ABSTRACTS OF JAPAN vol. 17, no. 25 (C-1017)18 January 1993 & JP-A-42 47 821 (KUBOTA CORP.) 3 September 1992**
- **PATENT ABSTRACTS OF JAPAN vol. 17, no. 93 (C-1029)24 February 1993 & JP-A-42 85 132 (NIPPON STEEL CORPORATION) 9 October 1992**
- **PATENT ABSTRACTS OF JAPAN vol. 15, no. 252 (C-844)26 June 1991 & JP-A-30 82 718 (SUMITOMO METAL INDUSTRIES) 8 April 1991**
- **PATENT ABSTRACTS OF JAPAN vol. 15, no. 76 (C-809)21 February 1991 & JP-A-23 01 520 (SUMITOMO METAL INDUSTRIES) 13 December 1990**

**EP 0 601 252 B1**

Note: Within nine months from the publication of the mention of the grant of the European patent, any person may give notice to the European Patent Office of opposition to the European patent granted. Notice of opposition shall be filed in a written reasoned statement. It shall not be deemed to have been filed until the opposition fee has been paid. (Art. 99(1) European Patent Convention).

## Description

The present invention relates to hearth rollers for conveying metal strips, and more particularly to hearth rollers having a suppressed heat crown in an area where a metal strip contacts the roller so that it is possible to convey metal strips at a high temperature in a stable manner.

In many processing lines such as a continuous heat treating furnace (e.g., continuous annealing furnace) many hearth rollers have been employed to convey metal strips (sometimes referred to merely as "strip" hereunder). In such conventional hearth rollers, a predetermined initial crown is provided in order to convey strips in a stable manner.

On the other hand, in a continuous annealing furnace, for example, hearth rollers provided within the furnace must carry metal strips having a variety of temperatures, widths, and thicknesses, and a heat crown is inevitably generated by such factors so that the initial roll crown of the roller cannot be kept to the predetermined one.

There are many problems caused by varied roll crowns. When the roll crown is excessive, buckling of strips, called "heat buckling", occurs, resulting in troubles in conveying metal strips as well as degradation in the quality of the product strips. When the roll crown is too small, the centering effect is weakened, resulting in occurrence of meandering of strips.

One solution to such problems caused by the occurrence of heat crown is, as is disclosed in Japanese Patent Application Unexamined Specification No. 61-210129/1986, to employ hearth rollers which can adjust the crown mechanically. As shown in Figure 11 a tapered surface 10 provided within the hearth roller 9 engages with an adjusting member 12. The position of the adjusting member 12 is movable along a longitudinal axis of the roller by means of an adjusting means 14 provided outside the roller. The roll crown can be adjusted by controlling the degree of inclination of the tapered surface 10 which engages with the adjusting member 12 so that a sleeve 16 can be deformed. A variation of the roll crown is caused by the occurrence of a heat crown, which is then derived from a variation in temperatures of the strip in the widthwise and longitudinal directions. According to this hearth roller, such roll crown variations can be mechanically offset by the deformation of the sleeve caused by the movement of the tapered surface, and a given level of crown can be maintained.

Japanese Patent Application Unexamined Specification No. 63-65016/1988 discloses another hearth roller which can prevent a heat crown by making the thermal distribution uniform throughout the roller. Such hearth rollers, as is shown in Figure 12, contain a molten metal 20 as a thermal medium within the roller 22 so that the temperature deviation in the axial direction of the roller barrel 24 can be diminished to suppress the occurrence of heat crown itself.

However, such hearth rollers as described above cannot prevent occurrence of heat crown effectively.

Namely, the hearth roller shown in Figure 11 requires a control system which can estimate or measure a change in heat crown whenever it occurs so as to maintain a predetermined roll crown. Such a control system adds to costs. There are still some other problems remaining with respect to lubrication, endurance, and the like of a variable crown mechanism when a hearth roller is used in a high temperature atmosphere, such as in a continuous annealing furnace.

On the other hand, a hearth roller shown in Figure 12 essentially utilizes the thermal content of the thermal medium. Since the thermal content is equal to the product of the specific heat by the mass, it is more advantageous to use a molten metal than a molten salt in order to make the temperatures of the roller uniform in the widthwise direction. This is because metals have a larger mass, i.e., a larger density than molten salts. However, when a metal is used, then the mass distribution of the roller is not uniform, and the roller is subjected to a centrifugal force, causing vibration. In order to prevent the roller from vibrating it is necessary to further employ additional equipment such as bearings. This also adds to costs. In the case of a molten salt, its effectiveness at producing uniformity of the roller temperature is degraded to some extent, although the costs are reduced, in comparison with the case in which a molten metal is used.

An object of the present invention is to provide hearth rollers which can avoid such problems of the prior art, and which does not require any specific control system, but which can maintain a predetermined initial crown in order to stably convey metal strips regardless of changes in carrying conditions of the metal strips.

Another object of the present invention is to provide hearth rollers with a suppressed heat crown in which a buffer effect is strengthened by increasing the heat transfer capability of the roller in order to offset changes in the temperature distribution in the widthwise direction which occur when metal strips having different widths are conveyed continuously.

Still another object of the present invention is to provide less expensive hearth rollers of a simple structure which are corrosion resistant and strong enough to withstand high temperature conditions at 1000°C such as experienced when strips are conveyed on the hearth rollers.

The inventor of the present invention found that a heat crown is mainly derived from the occurrence of a temperature gradient in the barrel of a hearth roller, i.e., in the hearth roller body, and that such a heat crown can be eliminated by achieving a rapid heat transfer through the body of a hearth roller to diminish such a temperature gradient, while ensuring high temperature strength and corrosion resistance.

The present invention is defined in claim 1. Preferred embodiments are defined in claims 2 - 8.

Figure 1 is a partial sectional view of a hearth roller of the present invention;

Figure 2a is a graph showing a heat crown of a hearth roller of the prior art;

Figure 2b is a graph showing a heat crown of a hearth roller of the present invention;

Figure 3a is an illustration of the dimensions of a standard hearth roller;

Figure 3b is an illustration of an embodiment of the hearth roller of the present invention;

Figure 4 is an illustration of heating a hearth roller;

Figure 5 shows graphs of changes in a heat crown as time elapses;

Figure 6 is an illustration of a heat crown of a conventional hearth roller used in a cooling zone of a continuous annealing furnace;

Figure 7 is an illustration of a heat crown of a hearth roller of the present invention used in a cooling zone of a continuous annealing furnace;

Figure 8 is the same as Figure 6 except that the roller is used in a heating zone;

Figure 9 is the same as Figure 7 except that the roller is used in a heating zone;

Figure 10 shows graphs of changes in a heat crown when the width of a strip is varied, and of changes in CRS after the width is varied;

Figure 11 is an illustration of a hearth roller of the prior art equipped with a heat crown adjusting mechanism; and

Figure 12 is an illustration of another hearth roller of the prior art.

Figure 1 is a schematic sectional view of a portion of a hearth roller of the present invention. The hearth roller 1 comprises a hearth roller barrel (outer sleeve) 2, a metallic sleeve (inner sleeve) 3, and an innermost sleeve 4. The metallic sleeve 3 has substantially the same linear expansion coefficient as that of the outer sleeve but exhibits further improved thermal conductivity, and is fitted to the inner surface of the outer sleeve by means such as shrink fit or duplex casting. The innermost sleeve 4 is fitted to the inner surface of the metallic sleeve 3 by means such as thermal insertion, i. e., shrink fit. A metal strip 6 is conveyed while being carried on the outer sleeve 2.

The ends of the inner sleeve 3 in the axial direction are positioned inwardly and separated from each of the ends of the outer sleeve 2 and are sealed with a metal member of a weld metal or a ring made of the same metal as the innermost sleeve 4. Namely, the inner sleeve 3 is totally isolated from the surrounding atmosphere. The inner sleeve 3 is made of a single piece, but it may be of a multi-piece type divided into pieces in the axial direction.

The axial end of the inner sleeve 3 is positioned inwardly from the axial end of the outer sleeve 2 which constitutes a hearth roller barrel. The distance  $d$  between the two ends is not restricted to a specific one, so

long as thermal streams are interrupted thoroughly between them. Usually the distance " $d$ " is about 1 mm.

The outer sleeve 2 and the innermost sleeve 4 may be made of the same or different metals. Usually it is desirable that these sleeves be made of same metal. On the other hand, the inner sleeve 3 is made of a metal different from that of these sleeves and exhibits improved thermal conductivity.

Usually a hearth roller is made of a stainless steel. This means that the sleeve 2 is made of a stainless steel. In this case, it is preferable from consideration of the thermal properties and material costs that the inner sleeve be made of copper. The innermost sleeve 4 and the ring 5 are also preferably made of stainless steel.

In another case, the outer sleeve 2, the innermost sleeve 4 and the ring 5 are made of a heat resistant steel, and the inner sleeve 3 is made of aluminum or silver.

In summary, in order to achieve the maximum merits of the present invention it is desirable that the outer sleeve 2, the innermost sleeve 4 and the ring 5 be made of a metal which exhibits improved heat resistance and that the inner sleeve 3 be made of a metal having improved thermal conductivity.

In the case in which the inner sleeve is made of copper, the service temperature thereof is up to about 500°C. The corrosion resistance and strength of a copper inner sleeve are adequate. However, when the hearth rollers are used at a temperature around 1000°C, which is near to the melting point of copper, the strength of copper is decreased markedly and oxidation of copper takes place. Thus, it is desirable that the inner sleeve be sealed in an inert atmosphere or vacuum, but the service life for a hearth roller comprising an outer sleeve the thickness of which has been reduced for the purposes of energy saving and economy is markedly reduced.

Next, heat conduction from a metal strip and formation of heat crown caused by such heat conduction will be described in conjunction with an example in which the hearth rollers are installed in a continuous annealing furnace. This is an example in which hearth rollers are placed in an atmosphere at a relatively low temperature and a metal strip at a high temperature is running on the hearth rollers.

In the case of a hearth roller having a conventional structure, i. e., hearth rollers without inner sleeves 3 and 4, a temperature gradient is found in an area near the edges of the strip, resulting in formation of heat crown as shown in Figure 2a.

On the other hand, according to the present invention, as shown in Figure 2b, the inner sleeve 3 made of copper is fitted into the outer sleeve 2 with the axial ends of the inner sleeve 3 being separated from those of the outer sleeve 2. The inner sleeve 3 is also isolated from the surrounding atmosphere by the innermost sleeve 4 and the ring 5. When a metal strip is conveyed under the same conditions as in Figure 2a, heat conduction in the axial direction is promoted and a temperature gra-

dient in the marginal areas is diminished, resulting in disappearance of heat crown. In the figure the abbreviation "CRS" stands for the amount of heat crown for width of strip.

Furthermore, in the embodiment shown in Figure 2b, since the inner sleeve made of copper is sealed from the outside, even if the copper is melted down, the strength of the hearth roller can be ensured by the outer sleeve which is made of a heat resistant steel, e.g., stainless steel. Oxidation of the copper can also be prevented because the inner sleeve is sealed. It is desirable, in this case, too, to place the inner sleeve in an inert gas or vacuum atmosphere. Thus, the hearth roller with improved properties of corrosion resistance can be used at a temperature of about 1000°C.

The thickness of the inner sleeve 3 is not restricted to a specific one, but it is preferable from the standpoint of improving heat conduction that the thickness of the inner sleeve 3 be larger than that of the outer sleeve 2. Usually the thickness of the inner sleeve is 10 - 30 mm.

The total thickness of the outer sleeve 2 and the innermost sleeve 4 is about 15 - 30 mm, which is substantially the same as that for the outer sleeve of the conventional roller which was designed taking creep strength and the like into consideration.

When the outer sleeve 2 and the innermost sleeve 4 are made of stainless steel and the inner sleeve is made of copper, the linear expansion coefficients for each of the sleeves are substantially the same. The formation of thermal stress is suppressed even if the temperature of the roller or metal strip is varied, and fitting of all these sleeves can be maintained with prevention of a tensile thermal stress which might cause creeping and the like.

The present invention will be further described in conjunction with working examples, which are presented merely for illustrative purposes.

#### Example

Figures 3a and 3b show the shapes and dimensions (mm) of the hearth rollers used in this example.

Figure 3a is a schematic sectional view of a conventional roller made of heat resistant stainless steel. This roller represents a comparative example.

Figure 3b shows a hearth roller of the present invention. The inner sleeve 3 made of copper is fitted into the outer sleeve 2, i.e., the hearth roller barrel made of heat resistant stainless steel, and the innermost sleeve 4 made of heat resistant stainless steel is then fitted into the inner sleeve by shrink fit. Both ends of the inner sleeve 3 are sealed by fitting the ring 5 made of heat resistant stainless steel to the outer and innermost sleeves by welding.

Substantially the same effectiveness of the present invention with respect to prevention of heat crown can be obtained when an inner sleeve 3 of the multi-piece type, i.e., combination of a plurality of rings, is used

compared with that of the single piece type. However, for ease of assembly in the production line, the single piece type is preferred.

A steel strip used in this example was an annealed steel strip having a thickness of 0.15 mm and a width of 280 mm. A heat crown formed while conveying the metal strip was measured during the conveying process with a measuring device of the contact type.

A model test simulating employment of the hearth roller of the present invention in a cooling zone of a continuous annealing furnace was carried out by conveying the strip in an atmosphere kept at 900°C on the hearth rollers. The strip was previously heated to a given temperature, e.g., 1000°C. This test will be indicated as "Model Test I" hereinafter.

On the other hand, another model test simulating employment of the hearth roller of the present invention in a heating zone of a continuous annealing furnace was carried out, as shown in Figure 4, by conveying the strip on the hearth rollers the outer sleeve 2 of which were heated to about 1000°C by means of an infrared heater 7 provided within the hearth roller 8. The strip was previously heated to a given temperature, e.g., 900°C. This test will be indicated as "Model Test II" hereinafter.

In both cases since the conveying was carried out for evaluating heat conduction, the roller had no initial crown.

Figure 5 is a graph of formation of heat crown with respect to the time elapses for the conventional hearth roller in Model Test I. In this example the temperature of the strip at the inlet of the roller was about 1060°C, and the heat crown reached a stationary level after about 30 minutes.

In the following test results, the heat crown was determined while conveying the strip on the hearth rollers and the heat crown determined was that on the stationary level.

Figures 6 and 7 are graphs showing heat crown for the conventional hearth roller and for the hearth roller of the present invention in Model Test I.

As is apparent therefrom, according to the present invention, the CRS decreased from 62 micrometers to 16 micrometers, and the gradient of heat crown in the axial direction was smooth.

Figures 8 and 9 are graphs showing the heat crown of the conventional hearth roller and the hearth roller of the present invention in Model Test II. The temperature of the surface of the hearth roller at the center in the axial direction was kept at about 980°C by adjusting the power of the heater 7.

As is apparent from the results, according to the present invention the CRS decreased from 33 micrometers to 2 micrometers.

Thus, according to the present invention the heat crown (CRS) could be reduced by about 74% in the cooling zone and about 94% in the heating zone, which are marked results. In addition, according to the present invention the gradient of heat crown in the axial direction

was smooth, which is very advantageous from a practical viewpoint. Troubles in operation during conveying strips occur mainly when the width of strips is changed, particularly the width of strips being conveyed changed from narrow to broad. This is because there is a marked increase in the CRS. Thus, according to the present invention such troubles can be eliminated completely.

Figure 10 is a graph showing what changes in the CRS occur immediately after the width of a strip is switched from the initial width of 280 mm to a smaller or larger one as indicated for the conventional hearth roller and for the hearth roller of the present invention in Model Test II.

As is apparent from the results shown in Figure 10, in the case of the conventional hearth roller, the CRS varied in a wide range, but in the case of the present invention the CRS was maintained at substantially the same level even when the width of a strip was changed to a larger one or a smaller one.

Thus, according to the present invention such troubles as occur in switching a strip to a different width can be eliminated completely.

It is also to be stressed that even for a hearth roller comprising an inner sleeve made of copper and outer and innermost sleeves and a ring each made of a heat resistant stainless steel, the resulting hearth roller can withstand a temperature of 1000°C with improved corrosion resistance, so that the hearth roller can be used continuously at 1200°C for over 500 hours.

#### Claims

1. A hearth roller comprising an outer sleeve 2 which constitutes a hearth roller barrel, an inner sleeve 3 fitted into the outer sleeve with the ends of the inner sleeve 3 in the axial direction being positioned inwardly and separated from each of the ends of the outer sleeve, and the inner sleeve having substantially the same linear expansion coefficient as that of the outer sleeve but exhibiting further improved thermal conductivity, characterized in that the hearth roller further comprises an innermost sleeve 4 fitted into the inner sleeve with the ends of the inner sleeve 3 in the axial direction being sealed by a metal, and in that the ends of the innermost sleeve in the axial direction and the sealing metal are positioned inwardly and separated from each of the ends of the outer sleeve.
2. A hearth roller as recited in Claim 1 wherein fitting of the inner sleeve 3 into the outer sleeve and the innermost sleeve into the inner sleeve is carried out by shrink fit.
3. A hearth roller as recited in Claim 1 wherein fitting of the inner sleeve 3 into the outer sleeve and the innermost sleeve into the inner sleeve is carried out

by duplex casting.

4. A hearth roller as recited in any one of Claims 1 - 3 wherein the outer sleeve and innermost sleeve are made of the same metal.
5. A hearth roller as recited in any one of Claims 1 - 4 wherein the ends of the inner sleeve is sealed by a ring 5, and the ring and innermost sleeve are made of the same metal.
6. A hearth roller as recited in any one of Claims 1 - 5 wherein the inner sleeve is made of copper, and the outer sleeve and innermost sleeve are made of a heat resistant stainless steel.
7. A hearth roller as recited in any one of Claims 1 - 6 wherein the inner sleeve is sealed in an inert atmosphere.
8. A hearth roller as recited in any one of Claims 1 - 7 wherein the inner sleeve is of the single piece type.

#### Patentansprüche

1. Herdrolle, umfassend eine äußere Büchse (2), die die Herdrollentrommel bildet, eine innere Büchse (3), die in der äußeren Büchse passend angeordnet ist, wobei die Enden der inneren Büchse (3) in Axialrichtung jeweils einwärts und getrennt von den Enden der äußeren Büchse angeordnet sind und die innere Büchse im wesentlichen den gleichen linearen Ausdehnungskoeffizienten wie die äußere Büchse (2) besitzt, jedoch eine verbesserte Wärmeleitfähigkeit aufweist, dadurch gekennzeichnet, dass die Herdrolle ferner eine innerste Büchse (4) umfaßt, die in der inneren Büchse passend angeordnet ist, wobei die Enden der inneren Büchse (3) in Axialrichtung durch ein Metall abgedichtet sind, und dass die Enden der innersten Büchse in Axialrichtung und das Dichtmetall jeweils einwärts und getrennt von den Enden der äußeren Büchse angeordnet sind.
2. Herdrolle nach Anspruch 1, wobei die Passung der inneren Büchse (3) in der äußeren Büchse und der innersten Büchse in der inneren Büchse durch eine Schrumpfpassung ausgeführt ist.
3. Herdrolle nach Anspruch 1, wobei die Passung der inneren Büchse (3) in der äußeren Büchse und der innersten Büchse in der inneren Büchse durch einen Duplexguß ausgeführt ist.
4. Herdrolle nach einem der Ansprüche 1 bis 3, wobei die äußere Büchse und die innerste Büchse aus

dem gleichen Metall bestehen.

5. Herdrolle nach einem der Ansprüche 1 bis 4, wobei die Enden der inneren Büchse durch einen Ring (5) abgedichtet sind und der Ring und die innerste Büchse aus dem gleichen Metall bestehen. 5
6. Herdrolle nach einem der Ansprüche 1 bis 5, wobei die innere Büchse aus Kupfer besteht und die äußere Büchse und die innerste Büchse aus einem wärmebeständigen rostfreien Stahl bestehen. 10
7. Herdrolle nach einem der Ansprüche 1 bis 6, wobei die innere Büchse in einer Inertatmosphäre abgedichtet ist. 15
8. Herdrolle nach einem der Ansprüche 1 bis 7, wobei die innere Büchse vom einstückigen Typ ist. 20

### Revendications

1. Rouleau de foyer comprenant un manchon extérieur 2 constituant un cylindre de rouleau de foyer, un manchon intérieur 3 ajusté dans le manchon extérieur, les extrémités du manchon intérieur 3 étant disposées dans la direction axiale à l'intérieur, et séparées de chacune des extrémités du manchon extérieur, et le manchon intérieur ayant à peu près le même coefficient de dilatation linéaire que celui du manchon extérieur, mais ayant une conductivité thermique encore améliorée, caractérisé en ce que le rouleau de foyer comprend en outre un manchon le plus intérieur 4 ajusté dans le manchon intérieur, les extrémités du manchon intérieur 3, dans la direction axiale, étant scellées à l'aide d'un métal, et en ce que les extrémités du manchon le plus intérieur, dans la direction axiale, et le métal de scellement, sont disposés à l'intérieur et séparés de chacune des extrémités du manchon extérieur. 25 30 35 40
2. Rouleau de foyer selon la revendication 1, dans lequel les ajustements du manchon intérieur 3 dans le manchon extérieur, et du manchon le plus intérieur dans le manchon intérieur, sont effectués par ajustement par retrait. 45
3. Rouleau de foyer selon la revendication 1, dans lequel les ajustements du manchon intérieur 3 dans le manchon extérieur, et du manchon le plus intérieur dans le manchon intérieur, sont effectués par ajustement par double coulage. 50
4. Rouleau de foyer selon l'une quelconque des revendications 1 à 3, dans lequel le manchon extérieur et le manchon le plus intérieur sont réalisés en le même métal. 55
5. Rouleau de foyer selon l'une quelconque des revendications 1 à 4, dans lequel les extrémités du manchon intérieur sont scellées par une bague 5, et la bague et le manchon le plus intérieur sont réalisés dans le même métal. 5
6. Rouleau de foyer selon l'une quelconque des revendications 1 à 5, dans lequel le manchon intérieur est réalisé en cuivre, et le manchon extérieur ainsi que le manchon le plus intérieur sont réalisés en un acier inoxydable résistant à la chaleur. 10
7. Rouleau de foyer selon l'une quelconque des revendications 1 à 6, dans lequel le manchon intérieur est scellé dans une atmosphère inerte. 15
8. Rouleau de foyer selon l'une quelconque des revendications 1 à 7, dans lequel le manchon intérieur est du type à une pièce. 20

*Fig. 1*

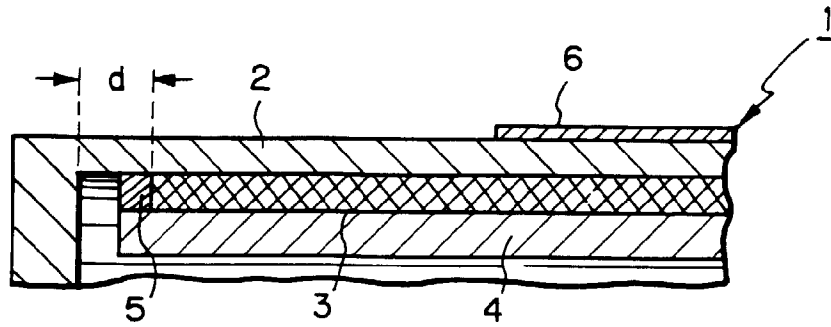

*Fig. 2a*

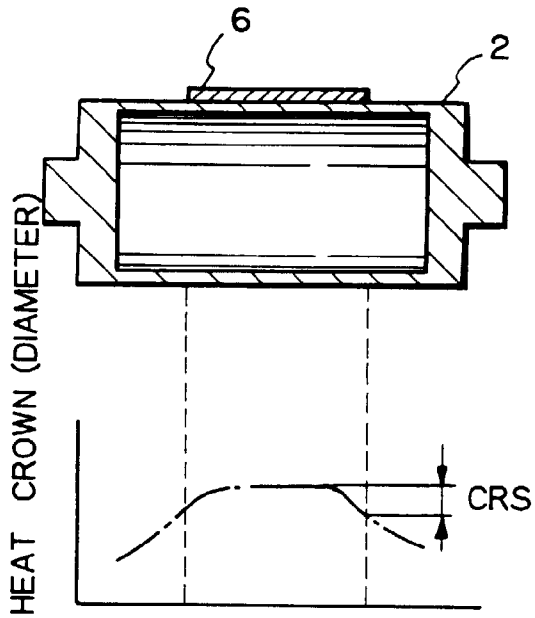

*Fig. 2b*

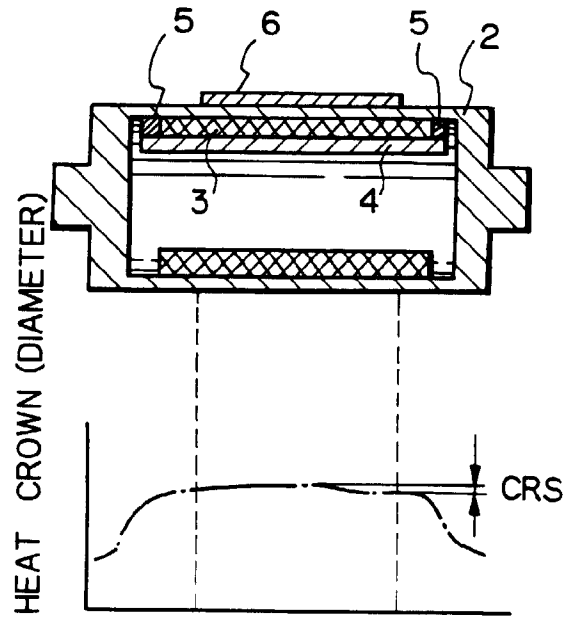

*Fig. 3a*

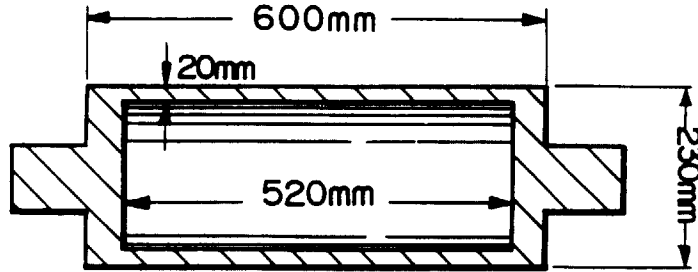

*Fig. 3b*

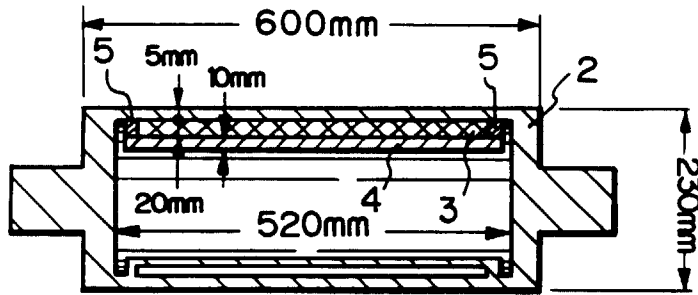

*Fig. 4*

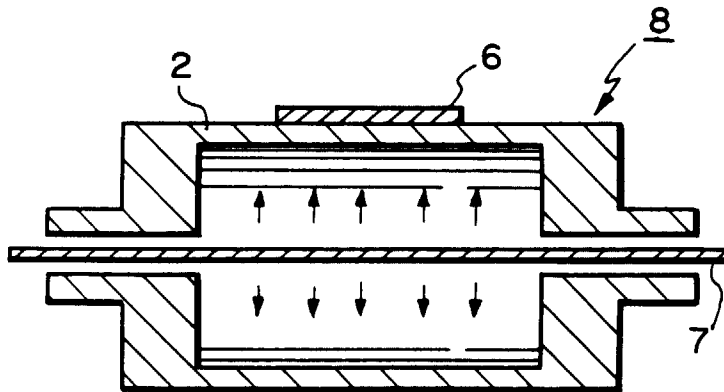
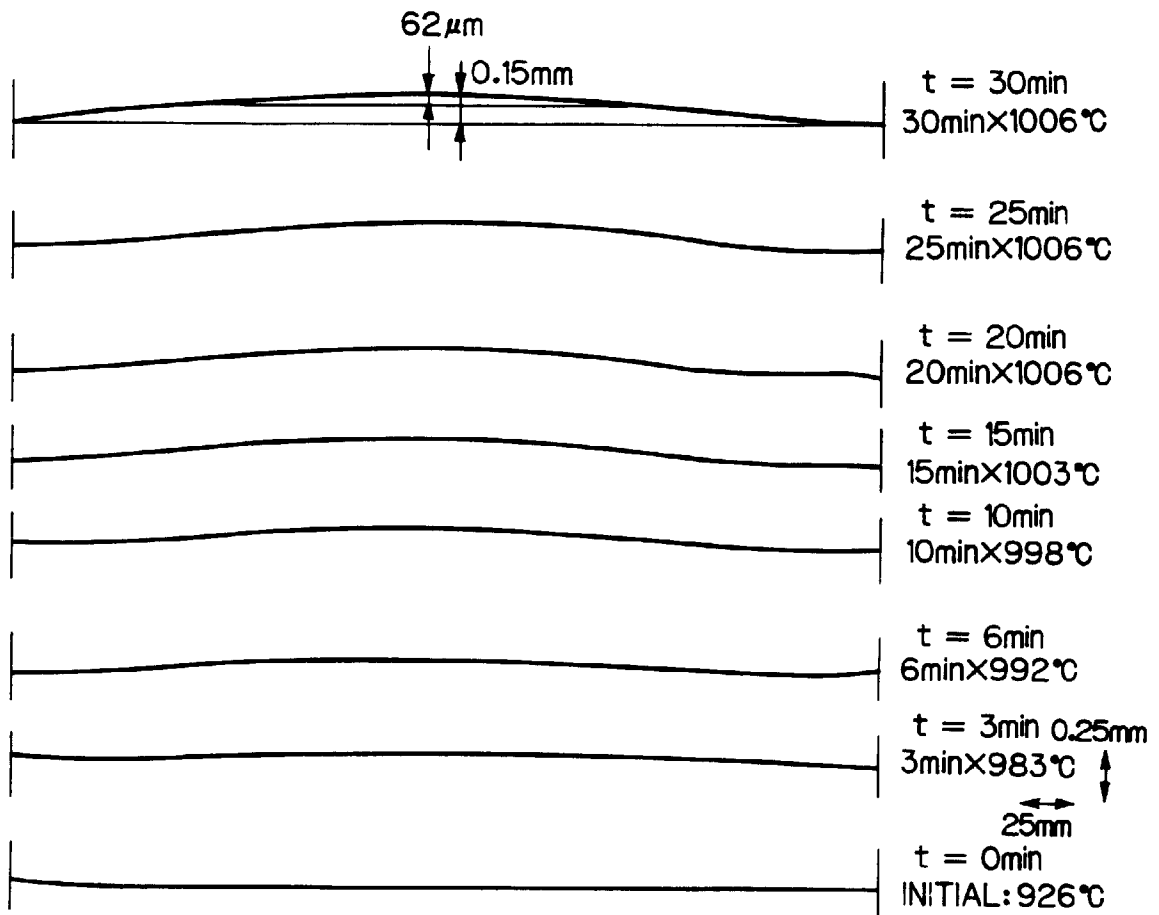
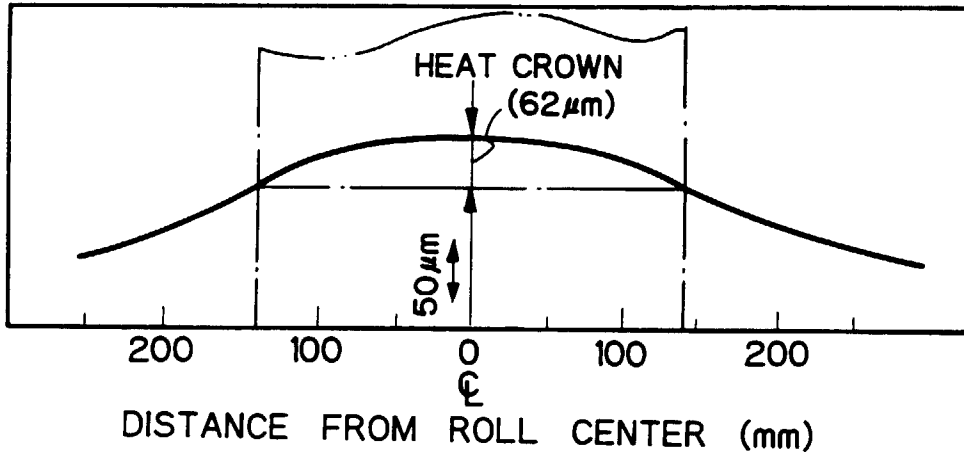

Fig. 5



*Fig. 6*



*Fig. 7*

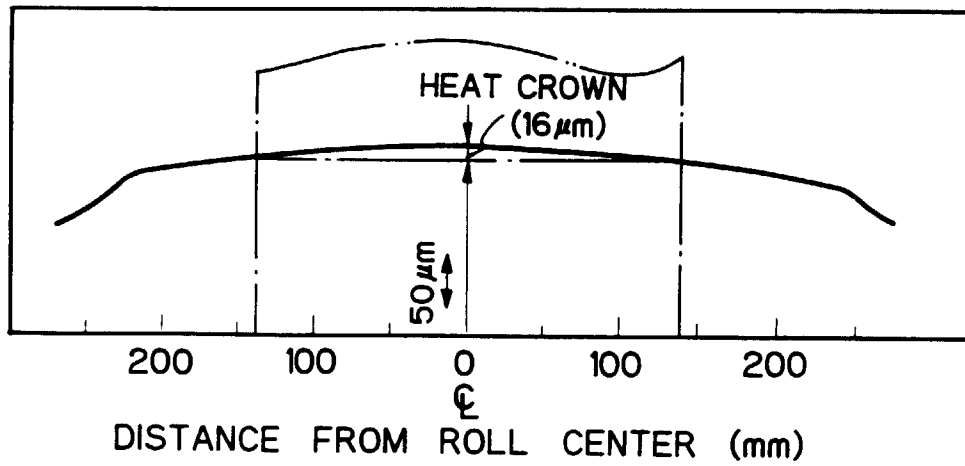

*Fig. 8*

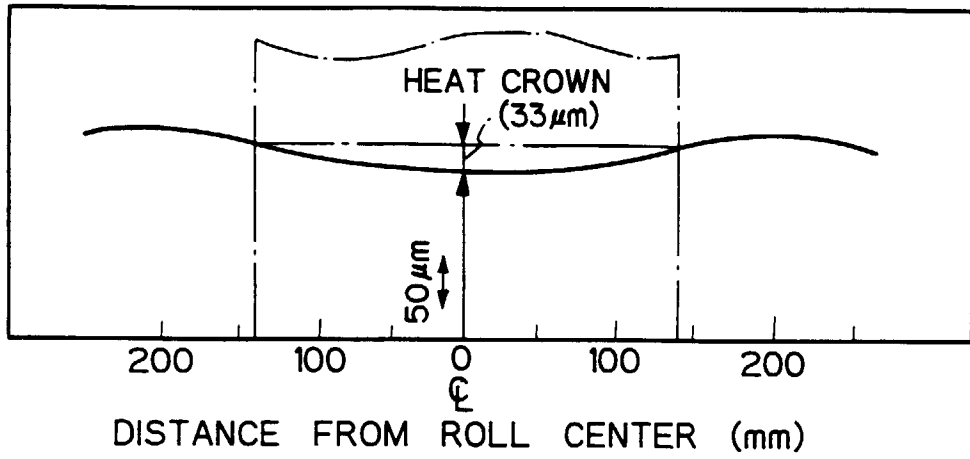

*Fig. 9*

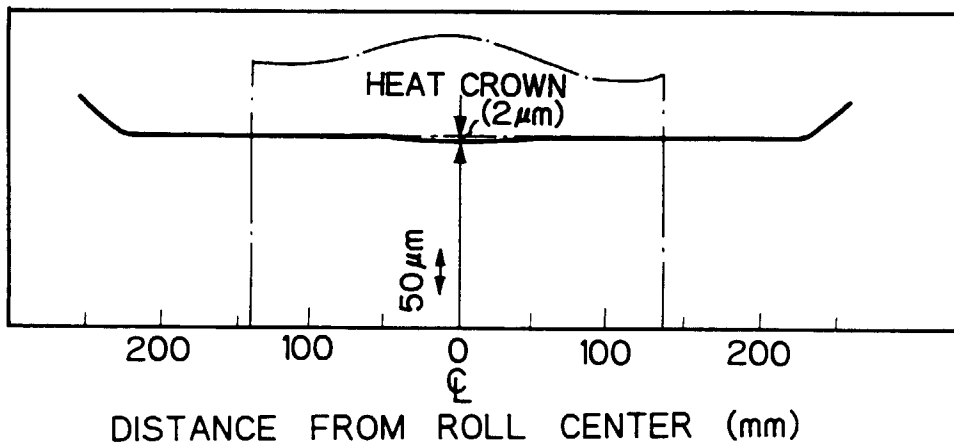

*Fig. 10*

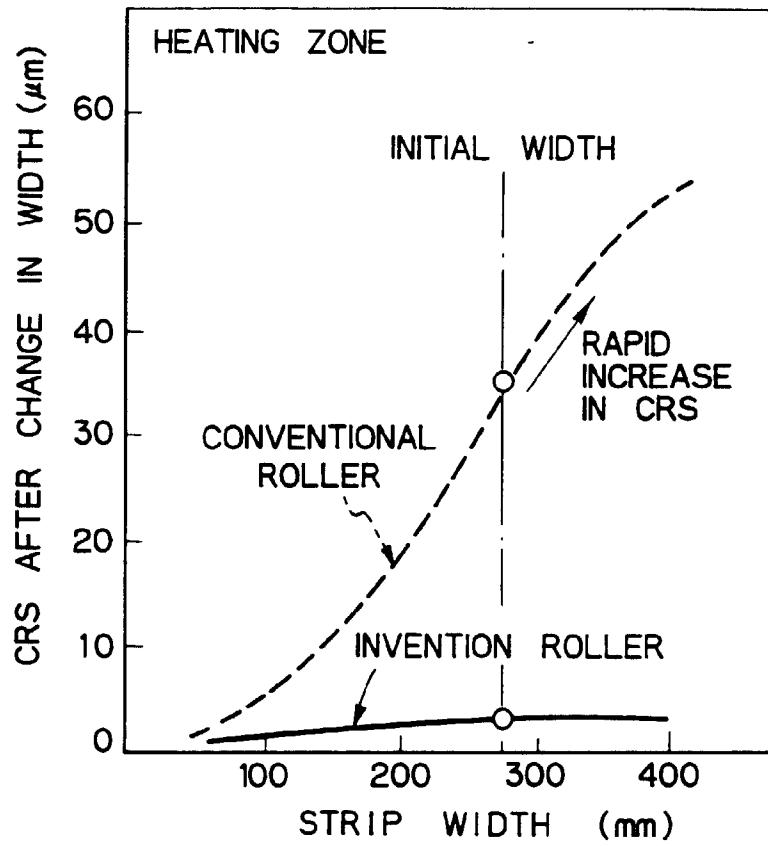

*Fig. 11*

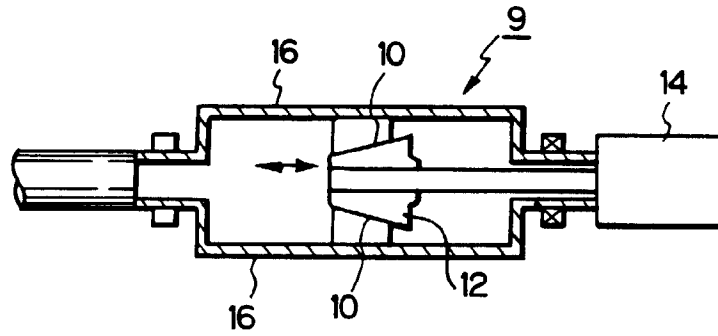

*Fig. 12*

