



US00D781727S

(12) **United States Design Patent**
Jackson et al.

(10) **Patent No.:** **US D781,727 S**

(45) **Date of Patent:** **** Mar. 21, 2017**

(54) **VEHICLE ALIGNER**

Primary Examiner — Antoine D Davis

(71) Applicant: **SNAP-ON, Incorporated**, Conway, AR (US)

(74) *Attorney, Agent, or Firm* — Miles & Stockbridge P.C.

(72) Inventors: **David A. Jackson**, Point Roberts, WA (US); **Adam C. Brown**, Maumelle, AR (US); **Ronald D. Swayne**, Sherwood, AR (US); **Brian K. Gray**, Conway, AR (US); **Bryan C. Minor**, Conway, AR (US); **Rodney Harrell**, Greenbrier, AR (US)

(57) **CLAIM**

The ornamental design for a vehicle aligner, as shown and described.

(73) Assignee: **SNAP-ON INCORPORATED**, Kenosha, WI (US)

DESCRIPTION

(**) Term: **15 Years**

FIG. 1 is a front isometric view of the vehicle aligner with its truss arms extended, showing the new design; FIG. 2 is a front elevation view of the vehicle aligner with its truss arms extended; FIG. 3 is a rear elevation view of the vehicle aligner with its truss arms extended; FIG. 4 is a side elevation view of the vehicle aligner with its truss arms extended; FIG. 5 is another side elevation view of the vehicle aligner with its truss arms extended; FIG. 6 is a top plan view of the vehicle aligner with its truss arms extended; FIG. 7 is a bottom plan view of the vehicle aligner with its truss arms extended; FIG. 8 is a front isometric view of the vehicle aligner with its truss arms retracted; FIG. 9 is a front elevation view of the vehicle aligner with its truss arms retracted; FIG. 10 is a rear elevation view of the vehicle aligner with its truss arms retracted; FIG. 11 is a side elevation view of the vehicle aligner with its truss arms retracted; FIG. 12 is another side elevation view of the vehicle aligner with its truss arms retracted; FIG. 13 is a top plan view of the vehicle aligner with its truss arms retracted; and, FIG. 14 is a bottom plan view of the vehicle aligner with its truss arms retracted.

(21) Appl. No.: **29/541,059**

(22) Filed: **Sep. 30, 2015**

(51) **LOC (10) Cl.** **10-04**

(52) **U.S. Cl.**
USPC **D10/65**

(58) **Field of Classification Search**
USPC D10/61, 62, 65, 70
CPC G01B 11/275; G01B 2210/00; G01B 2210/10; G01B 2210/12; G01B 2210/14; G01B 2210/143; G01B 2210/146; G01B 2210/16; G01B 2210/18; G01B 2210/20; G01B 2210/22; G01B 2210/24; G01B 2210/26; G01B 2210/28; G01B 2210/283
See application file for complete search history.

(56) **References Cited**

U.S. PATENT DOCUMENTS

D699,601 S * 2/2014 Larson D10/65
9,267,780 B2 * 2/2016 Abe G01B 5/008

* cited by examiner

1 Claim, 14 Drawing Sheets

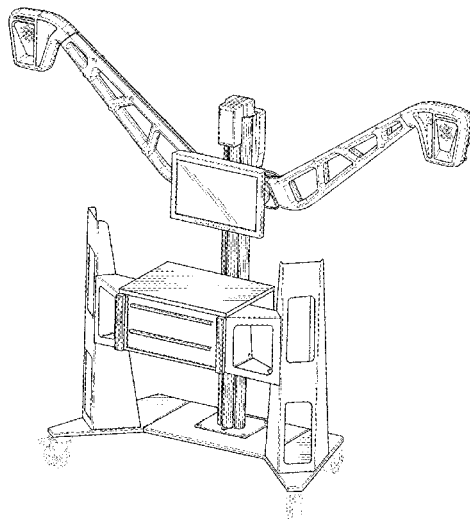

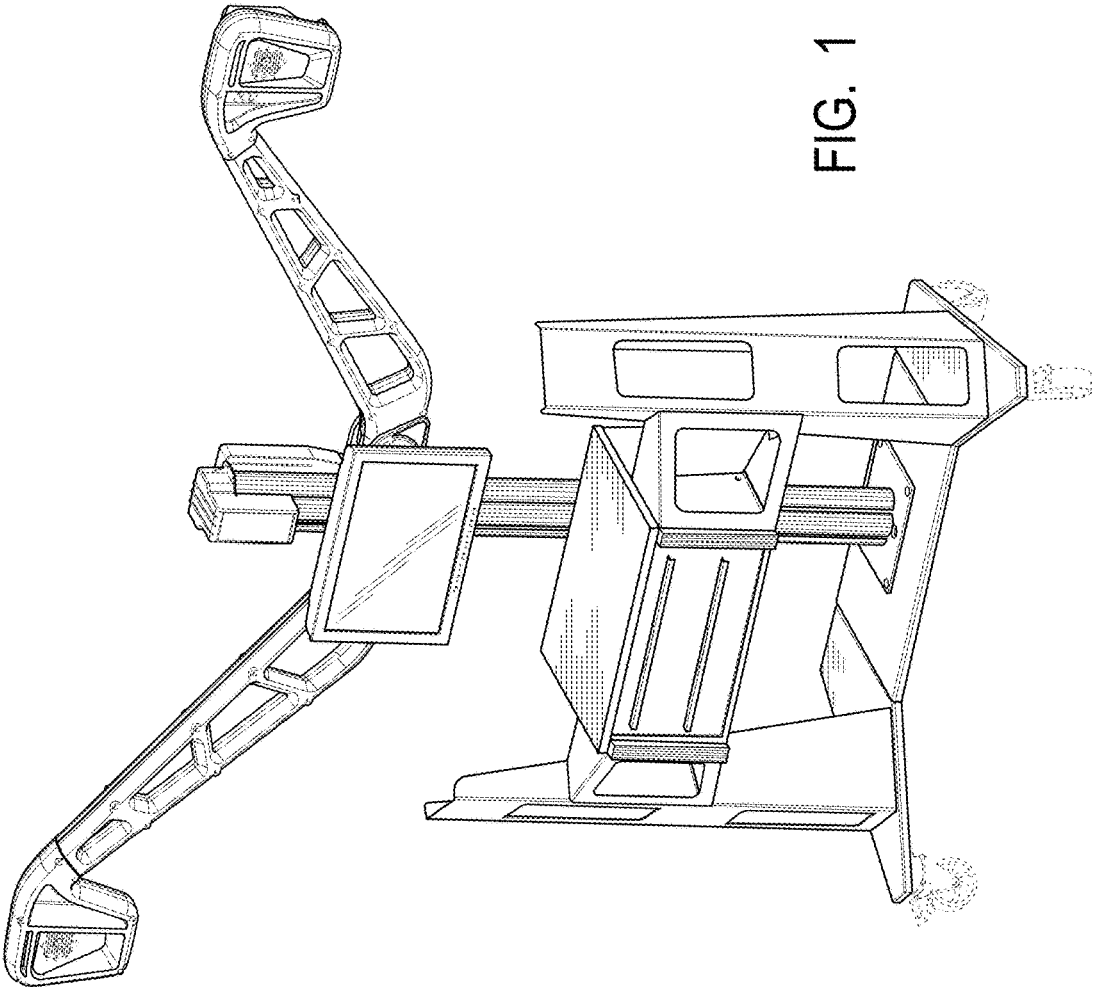

FIG. 1

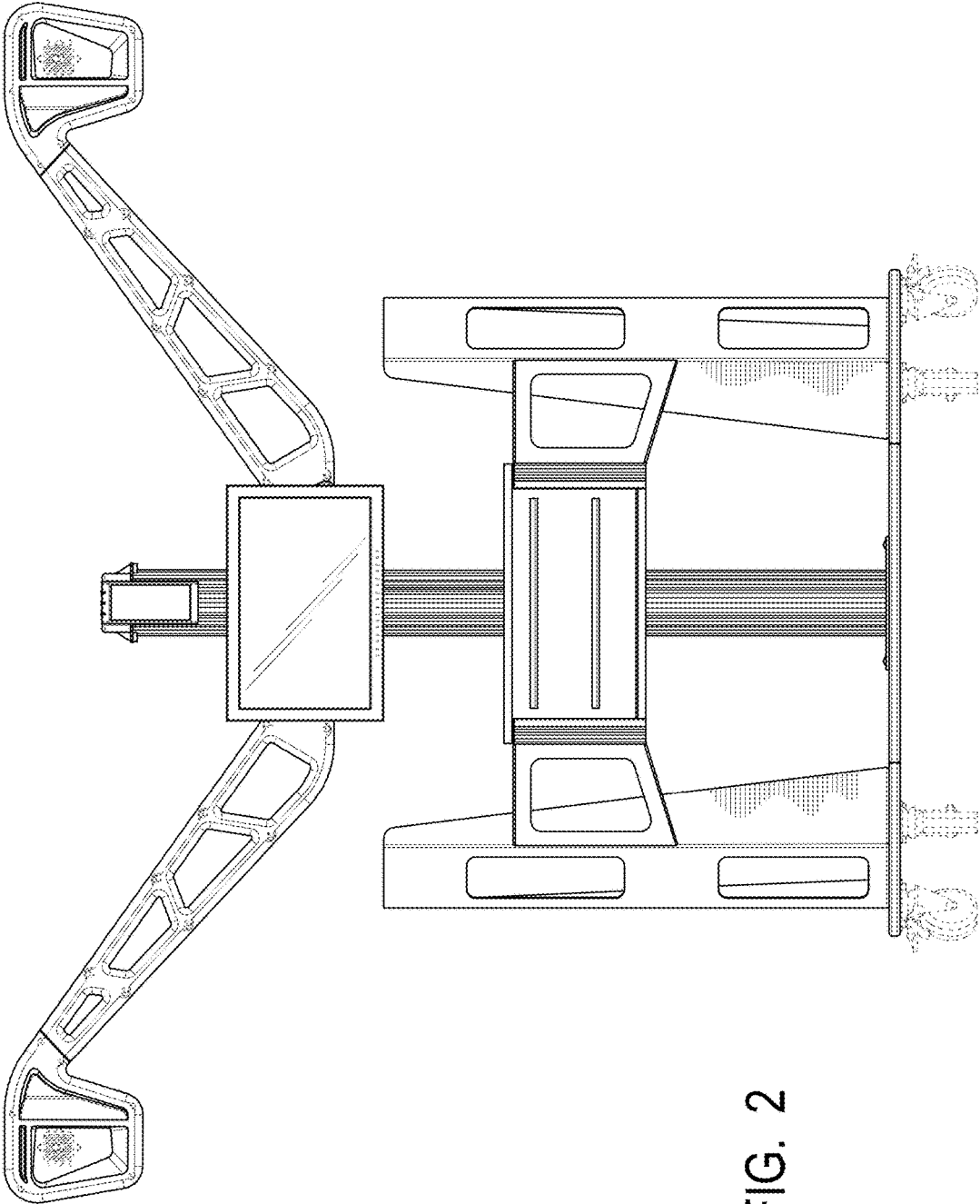

FIG. 2

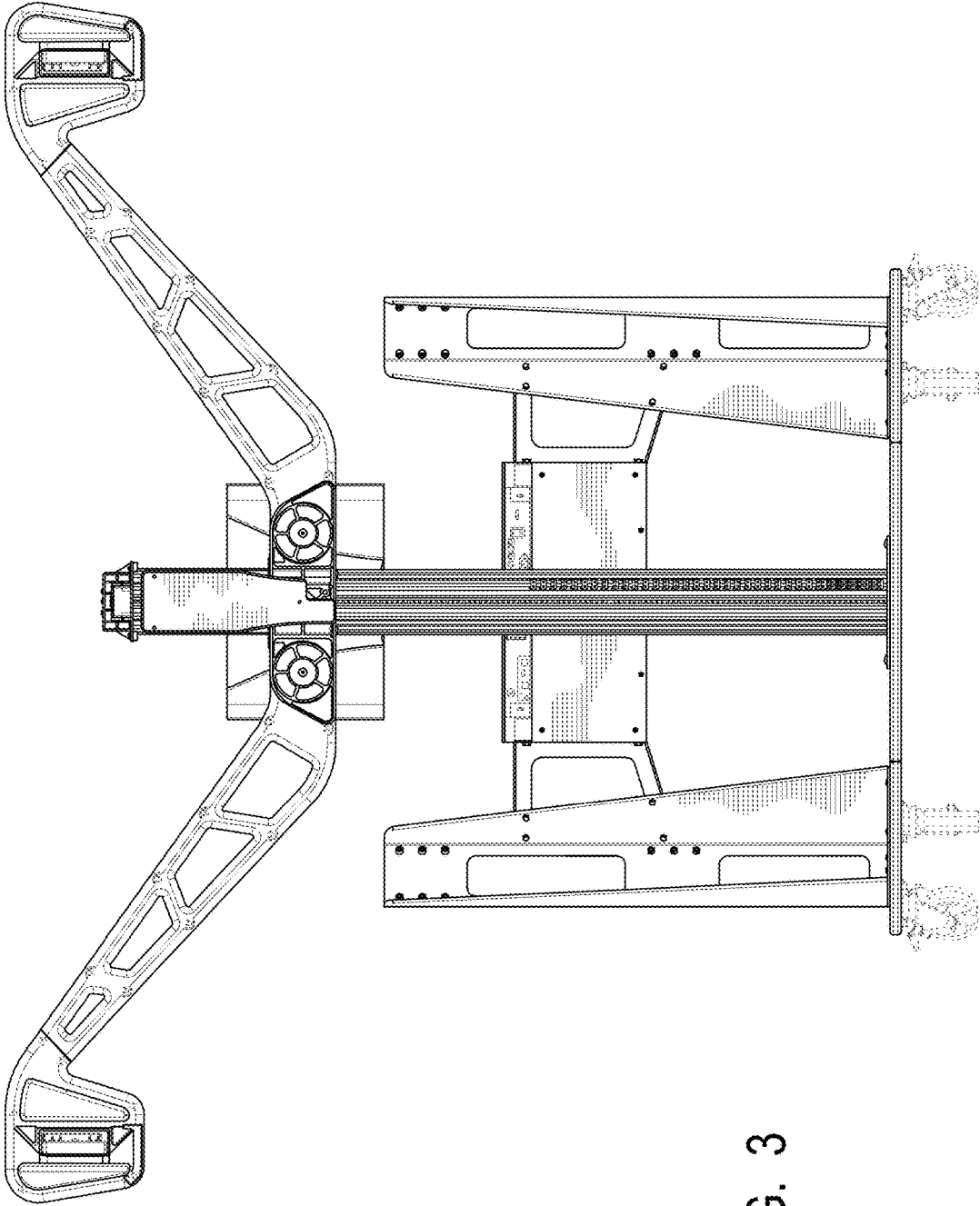
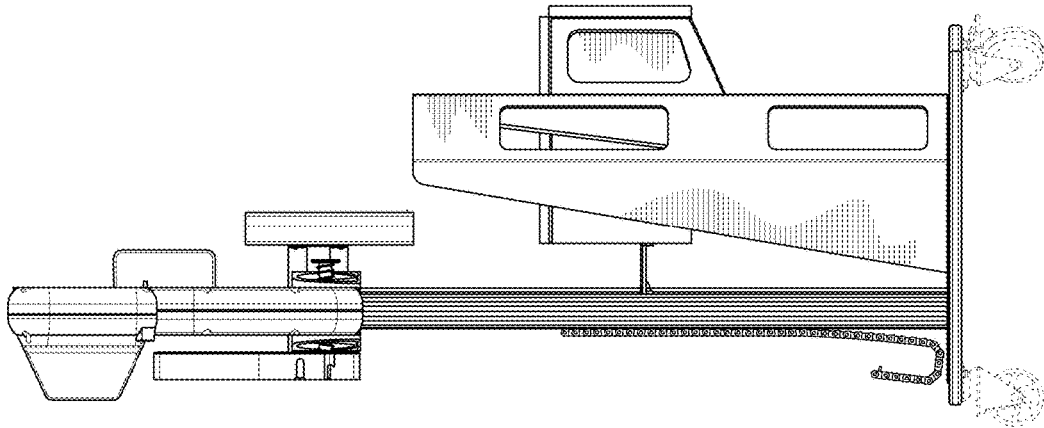

FIG. 3

FIG. 4



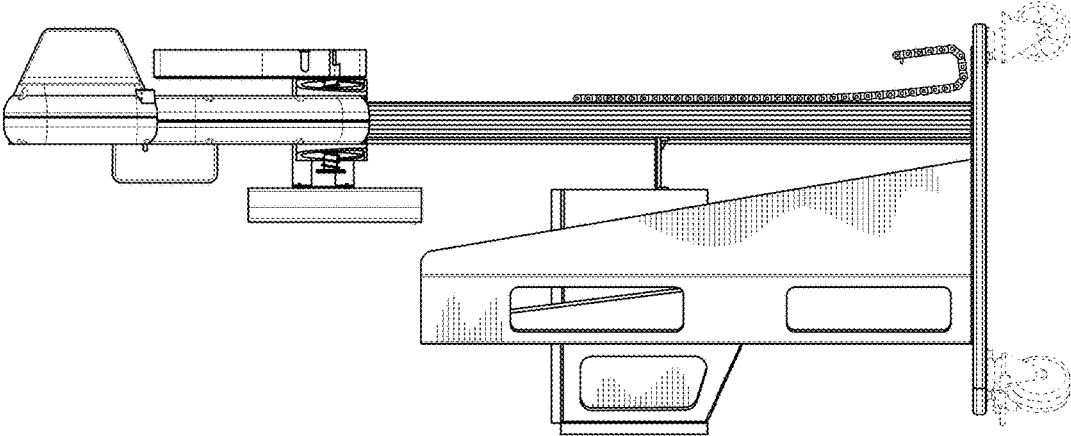

FIG. 5

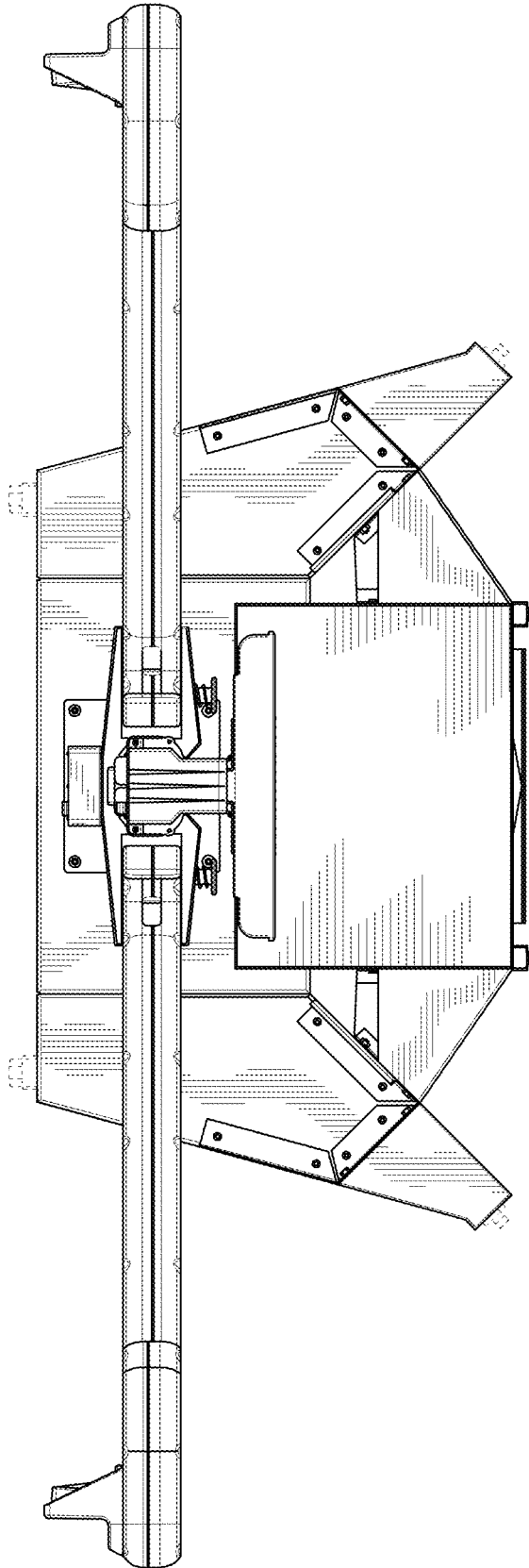

FIG. 6

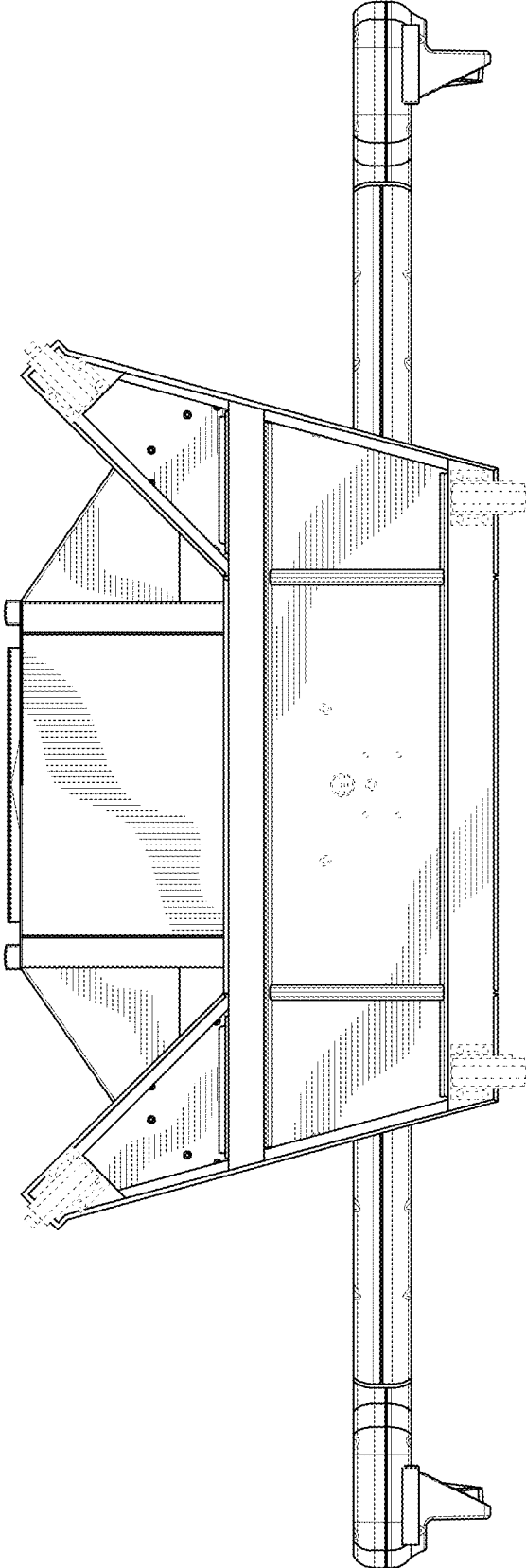
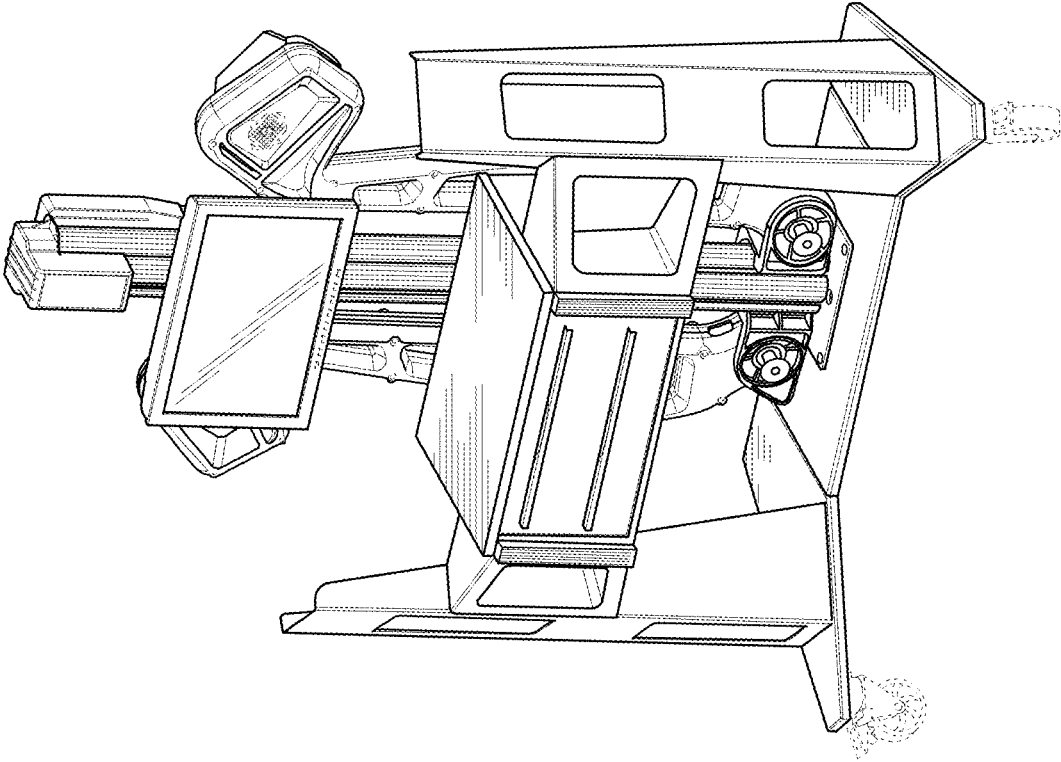

FIG. 7

FIG. 8



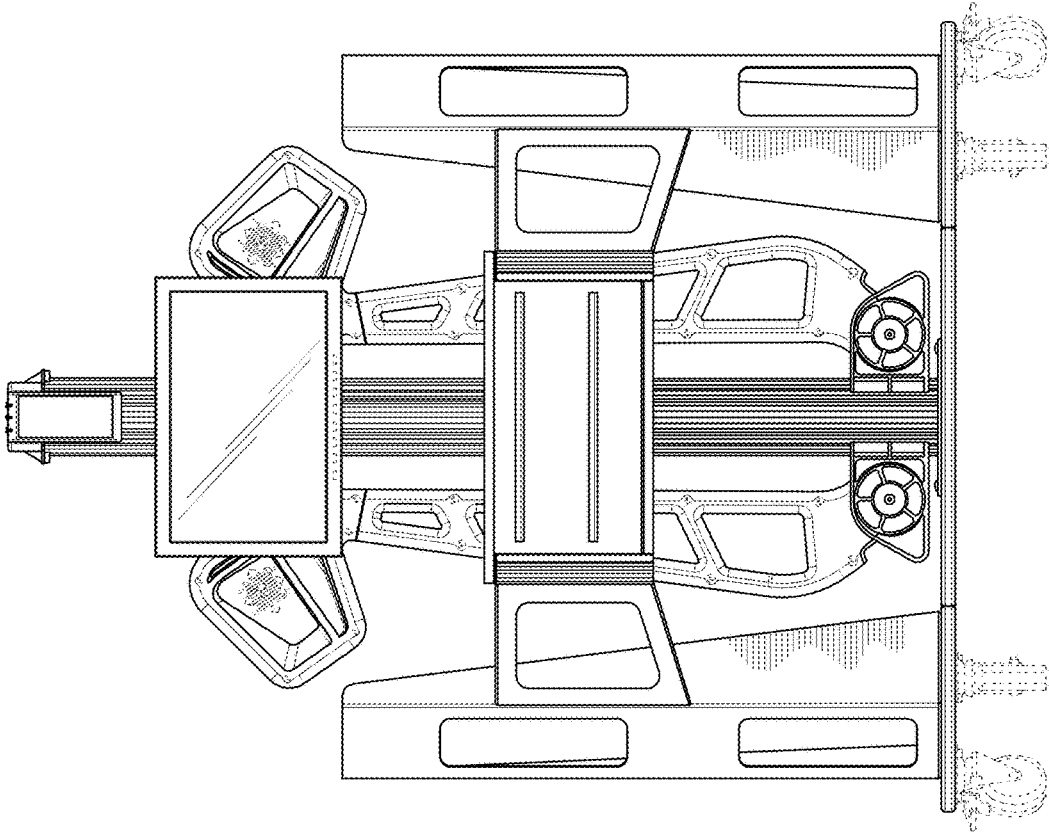

FIG. 9

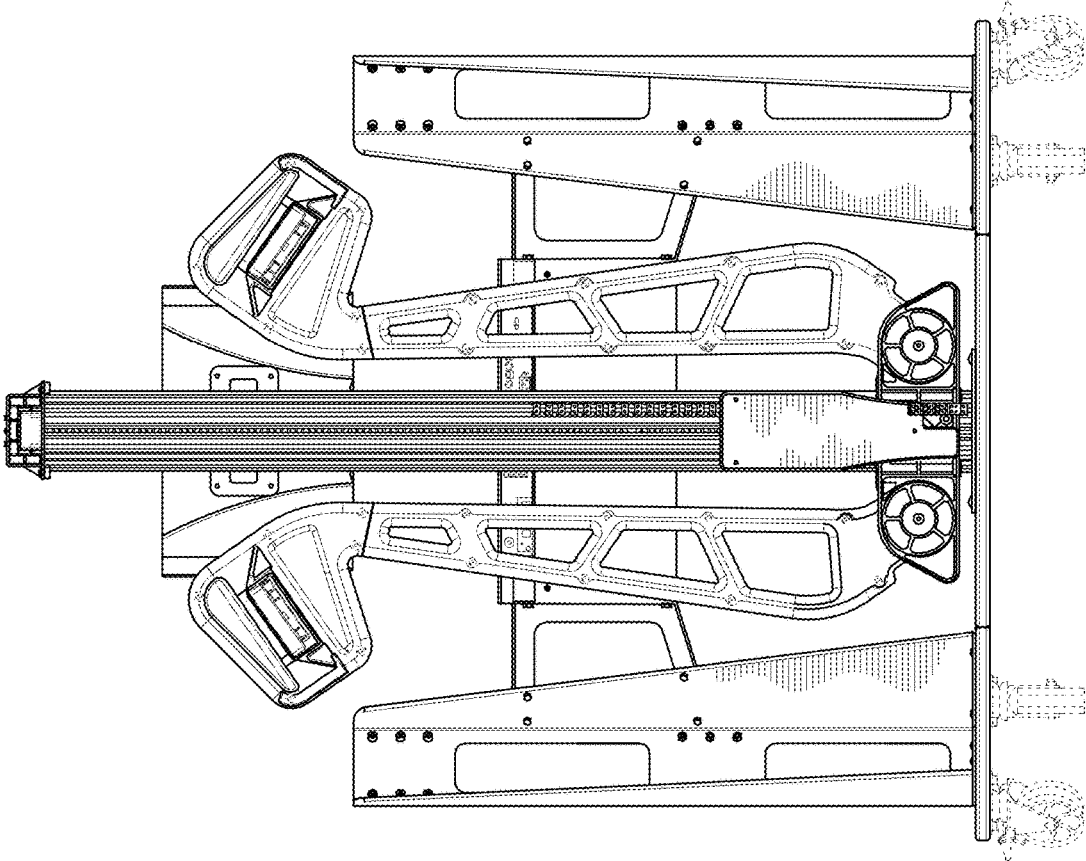

FIG. 10

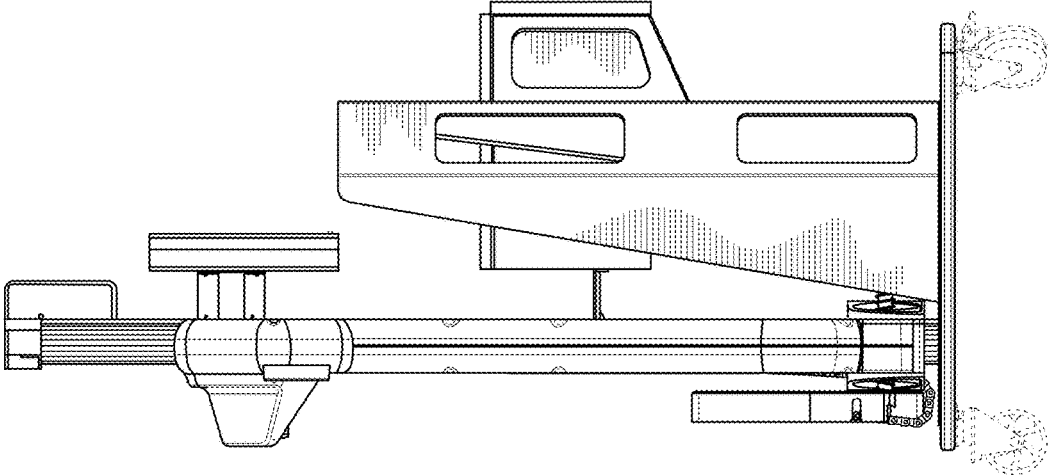

FIG. 11

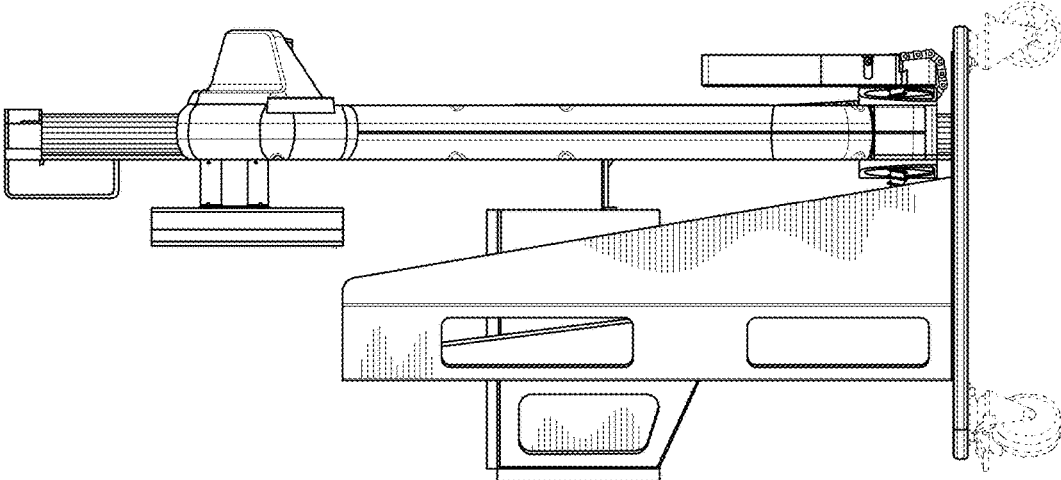

FIG. 12

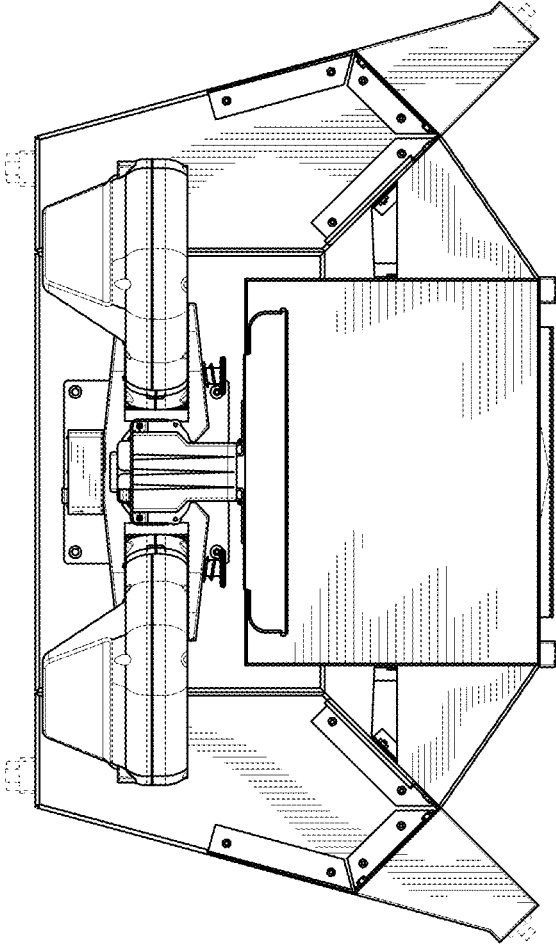

FIG. 13

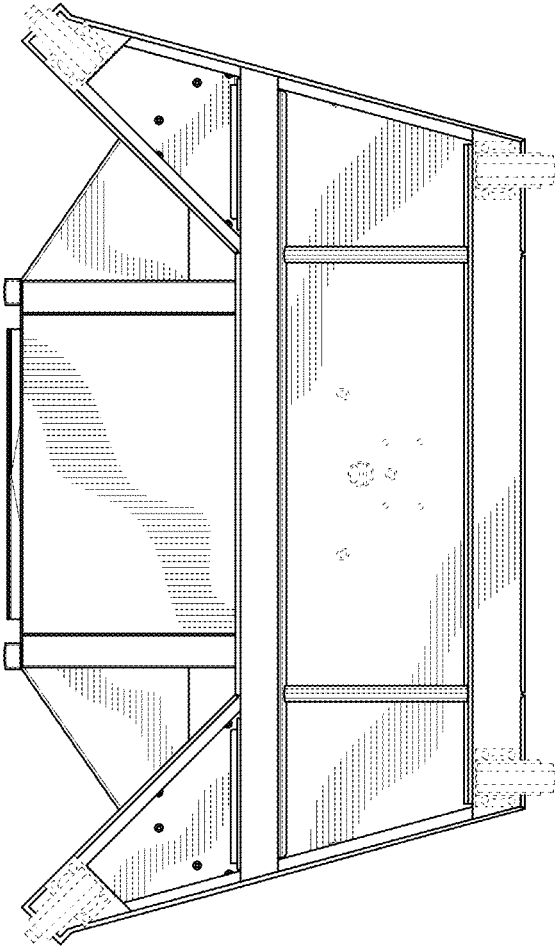

FIG. 14