

(19)



(11)

EP 4 571 108 A1

(12)

EUROPEAN PATENT APPLICATION

(43) Date of publication:
18.06.2025 Bulletin 2025/25

(51) International Patent Classification (IPC):
F04B 35/04^(2006.01)

(21) Application number: **23216496.2**

(52) Cooperative Patent Classification (CPC):
F04B 35/045

(22) Date of filing: **14.12.2023**

(84) Designated Contracting States:
**AL AT BE BG CH CY CZ DE DK EE ES FI FR GB
 GR HR HU IE IS IT LI LT LU LV MC ME MK MT NL
 NO PL PT RO RS SE SI SK SM TR**
 Designated Extension States:
BA
 Designated Validation States:
KH MA MD TN

(71) Applicant: **BSH Hausgeräte GmbH**
81739 München (DE)

(72) Inventors:

- **Vapnár, Jozef**
07101 Michalovce (SK)
- **Stavrovsky, Vladimir**
07101 Michalovce (SK)
- **Bocinec, Matus**
07101 Michalovce (SK)

(54) **LINEAR COMPRESSOR WITH A LINEAR ELECTRIC MOTOR**

(57) The invention relates to a linear compressor (1) with a linear electric motor comprising a stator (2) with a coil (3) and a mover (4), wherein the mover (4) has a magnet ring (5) made of a permanent magnet, a yoke (6)

for distributing the magnetic field and a cylinder (7), wherein a first wave retaining ring (8) is arranged in a first circular groove (9) in the yoke (6) next to the magnet ring (5).

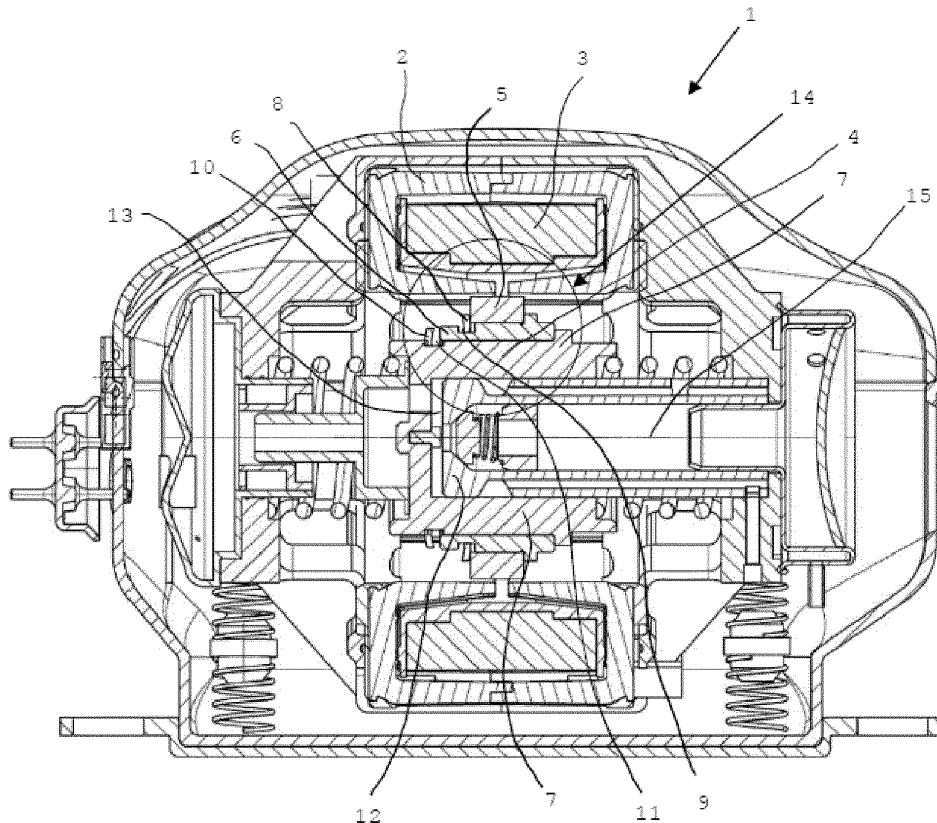

Fig. 1

EP 4 571 108 A1

Description

Technical area

[0001] The present invention relates to a linear compressor with a linear electric motor comprising a stator with a coil and a mover, in particular for a household appliance.

Prior art

[0002] Several linear compressors with linear electric motors are known from the prior art.

[0003] US8876497B2 discloses a linear compressor comprising a cylinder having a compression space for refrigerant therein, a piston that reciprocates linearly within the cylinder in an axial direction to compress the refrigerant, and a frame having a mounting hole so that one end of the cylinder can be mounted thereon and a deformation preventing portion in a portion around the mounting hole that is brought into contact with the one end of the cylinder. Even if the size of the cylinder is increased and the size of the frame is limited, the frame obtains sufficient strength to support the cylinder, thereby reducing mounting deformations and improving operational reliability.

[0004] One disadvantage of this linear compressor is that the linear compressor is subject to strong temperature changes due to the compression of the coolant, which can damage the moving parts of the linear compressor. This can shorten the service life of the linear compressor.

[0005] The problem of the present invention is therefore to provide a linear compressor with a linear electric motor which ensures reliable operation even in the event of severe temperature changes.

Description of the invention

[0006] The invention relates to a linear compressor with a linear electric motor comprising a stator with a coil and a mover, wherein the mover has a magnet ring made of a permanent magnet, a yoke for distributing the magnetic field and a cylinder, wherein a first wave retaining ring is arranged in a first circular groove in the yoke next to the magnet ring.

[0007] The cylinder of the linear compressor can move along a linear path to minimize friction and reduce energy loss during motion conversion compared to conventional compressors. This technology has been successfully used in cryogenic applications, which can be oil-free. The linear compressor with valve therefore enables the use of compact heat exchangers. The linear compressor can be connected to alternating current, for example by means of a diode. The cylinder can be spring-loaded and moved relative to a fixed piston by means of the mover, which is driven by the linear electric motor. During a positive cycle of the alternating current, the diode allows

current to flow through the stator's electromagnet and creates a magnetic field which acts on the mover and consequently moves the cylinder backwards away from the piston, compressing the spring and consequently creating suction so that the gas medium or coolant is drawn into a compression chamber. During a negative cycle of the alternating current, the diode can block the current flow to the stator's electromagnet, which relaxes the spring, moves the piston forward and compresses the refrigerant. The compressed refrigerant can then be discharged via a valve to achieve the desired cooling effect.

[0008] The linear compressor can be used for example for refrigerators.

[0009] The linear electric motor can have a stator in the form of a cylindrical coil with further stator segments and the mover inside the stator.

[0010] The yoke is suitable for distributing the magnetic field so that the driving force of the linear electric motor is amplified.

[0011] The elastic properties of the first wave retaining ring in the first circular groove in the yoke next to the magnet ring make it possible to cushion the compressive forces and compensate for the expansion and contraction of the components of the mover caused by temperature changes.

[0012] Advantageously, a second wave retaining ring can additionally be arranged in a second circular groove on an outer surface of the cylinder next to a first side of the annular yoke.

[0013] The second wave retaining ring in the second circular groove additionally compensates for the expansions and contractions of the mover's components caused by temperature changes using the elastic properties of the second wave retaining ring.

[0014] Advantageously, the mover comprising the magnet ring, the yoke and the cylinder can be shaped with circular symmetry relative to an axis of symmetry of the mover.

[0015] The circularly symmetrical design relative to the axis of symmetry of the component of the mover ensures an even distribution of the frictional forces that occur.

[0016] Advantageously, the magnet ring, the yoke and the cylinder can be made of different materials with different coefficients of thermal expansion.

[0017] The magnet ring can be made of any permanent magnet, whereby the cylinder can be made of steel. By choosing different materials with different coefficients of thermal expansion, correspondingly higher expansions and contractions of the components of the mover are caused by temperature changes.

[0018] Advantageously, the first wave retaining ring and/or the second wave retaining ring can be shaped and designed with respect to elasticity in such a way that expansion and/or contraction of the components of the mover, namely the magnet ring, the yoke and the cylinder, in a direction parallel to the axis of symmetry of the mover, which are caused by temperature changes and/or by

different materials with different coefficients of thermal expansion, are compensated.

[0019] As a result, the expansions and contractions that occur are reliably compensated for by the arrangement of the first wave retaining ring and/or the second wave retaining ring.

[0020] Advantageously, the first wave retaining ring may be arranged and shaped to exert a compressive force on a wall of the first groove on a first side of the magnet ring upon movement of the mover in one direction or to exert a compressive force on the magnet ring upon movement of the mover in an opposite direction while transmitting a reaction force to a shoulder of the yoke on an opposite second side of the magnet ring.

[0021] As a result, forces occurring during the movement of the mover are slightly cushioned by the elastic effect of the first wave retaining ring, preventing possible damage to the mover.

[0022] Advantageously, the second wave retaining ring may be arranged and shaped to exert a compressive force on a wall of the second groove on a first side of the yoke upon movement of the mover in one direction or to exert a compressive force on the yoke upon movement of the mover in an opposite direction, whereby a reaction force is transmitted to a shoulder of the cylinder on an opposite second side of the yoke.

[0023] As a result, forces occurring during the movement of the mover are easily absorbed by the elastic effect of the additional second wave retaining ring, preventing possible damage to the mover.

[0024] Advantageously, the mover can be designed in such a way that radial expansions or contractions of the mover components, namely the magnet ring, the yoke and the cylinder, caused by temperature changes are compensated for by radial gaps between the mover components.

[0025] The radial gaps are therefore dimensioned in such a way that the radial expansions and contractions of the components are compensated for by temperature changes.

[0026] Advantageously, a piston can be arranged inside the cylinder, whereby the oscillating movement of the cylinder relative to the stationary piston compresses a gas medium or a coolant in a chamber between the piston and the cylinder and then the compressed gas medium or coolant is drained through an outlet valve in order to achieve the desired cooling effect.

[0027] This achieves the desired cooling effect by draining the compressed coolant via the outlet valve.

Brief description of the drawings

[0028] The invention is explained with reference to the following drawings:

Fig. 1 a schematic representation of a linear compressor with a linear electric motor;

Fig. 2 an enlarged view of an area from Fig. 1;

Fig. 3 a three-dimensional schematic representation of the mover in an exploded view;

Fig. 4 a three-dimensional schematic representation of the mover 4 from Fig. 3 in an assembled state;

Fig. 5 a schematic representation of the mover from Fig. 3 in the assembled state in a side view and a sectional view.

Embodiments

[0029] Fig. 1 shows a schematic representation of a linear compressor 1 with a linear electric motor comprising a stator 2 with a coil 3 and a mover 4, the mover 4 having a magnet ring 5 made of a permanent magnet, a yoke 6 for distributing the magnetic field and a cylinder 7, wherein a first wave retaining ring 8 with an axial waveform is arranged in a first circular groove 9 in the yoke 6 next to the magnet ring 5 and a second wave retaining ring 10 with an axial waveform is arranged in a second circular groove 11 on an outer surface of the cylinder 7. A piston 12 is arranged inside the cylinder 7, whereby a gas medium or a coolant is compressed in a chamber 13 between the piston 12 and the cylinder 7 by the oscillating movement of the cylinder 7 relative to the stationary piston 12. The circled area 14 is shown enlarged in Fig. 2. The components of the mover 4, namely the magnet ring 5, the yoke 6 and the cylinder 7, are circularly symmetrical relative to an axis of symmetry 15 of the mover 4.

[0030] Fig. 2 shows an enlarged view of the circled area 14 of Fig. 1. The first wave retaining ring 8 is arranged and shaped to exert a compressive force on a wall 20 of the first groove 9 on a first side 21 of the magnet ring 5 upon movement of the mover 4 in a first direction, or to exert a compressive force on the magnet ring 5 upon movement of the mover 4 in an opposite second direction, while transmitting a reaction force to a shoulder 22 of the yoke 6 on an opposite second side 23 of the magnet ring 5. The second wave retaining ring 10 is arranged and shaped to exert a compressive force on a wall 24 of the second groove 11 on a first side 25 of the yoke 6 upon movement of the mover 4 in one direction or to exert a compressive force on the yoke 6 upon movement of the mover 4 in an opposite direction, wherein a reaction force is transmitted to a shoulder 26 of the cylinder 7 on an opposite second side 27 of the yoke 6. A first gap 28 between the cylinder 7 and the yoke 6 and a second gap 29 between the yoke 6 and the magnet ring 5 are designed such that radial expansions or contractions of the components of the mover caused by temperature changes are compensated.

[0031] Fig. 3 shows a three-dimensional schematic representation of the mover 4 in an exploded view, com-

prising the cylinder 7 with the second groove 11, the yoke 6 with the first groove 9, the first wave retaining ring 8, the magnet ring 5 and the second wave retaining ring 10.

[0032] Fig. 4 shows the mover 4 from Fig. 3 in an assembled state, whereby the axial waveform of the first wave retaining ring 8 and the second wave retaining ring 10 is clearly recognizable.

[0033] Fig. 5 shows a schematic representation of the mover 4 of Fig. 3 in the assembled state in a side view and a sectional view through the plane AA, which is represented by a line.

List of reference symbols

[0034]

1	linear compressor
2	stator
3	coil
4	mover
5	magnet ring
6	yoke
7	cylinder
8	first wave retaining ring
9	first groove
10	second wave retaining ring
11	second groove
12	piston
13	chamber
14	circled area
15	axis of symmetry
20	wall of the first groove
21	first side of the magnet ring
22	shoulder of the yoke
23	second side of the magnet ring
24	wall of the second groove
25	first side of the yoke
26	shoulder of the cylinder
27	second side of the yoke
28	first gap
29	second gap

Claims

1. Linear compressor (1) with a linear electric motor comprising a stator (2) with a coil (3) and a mover (4), wherein the mover (4) has a magnet ring (5) made of a permanent magnet, a yoke (6) for distributing the magnetic field and a cylinder (7), wherein a first wave retaining ring (8) is arranged in a first circular groove (9) in the yoke (6) next to the magnet ring (5).
2. Linear compressor (1) according to claim 1, wherein a second wave retaining ring (10) is additionally arranged in a second circular groove (11) on an outer surface of the cylinder (7) next to a first side (25) of the annular yoke (6).

3. Linear compressor (1) according to claim 1 or 2, wherein the mover (4) comprising the magnet ring (5), the yoke (6) and the cylinder (7) is shaped with circular symmetry relative to an axis of symmetry (15) of the mover (4).
4. The linear compressor (1) according to any one of claims 1-3, wherein the magnet ring (5), the yoke (6) and the cylinder (7) are made of different materials with different coefficients of thermal expansion.
5. The linear compressor (1) according to any one of claims 1-4, wherein the first wave retaining ring (8) and/or the second wave retaining ring (10) are shaped and designed with respect to elasticity such that expansion and/or contraction of the components of the mover (4), namely the magnet ring (5), the yoke (6) and the cylinder (7), in a direction parallel to the axis of symmetry (15) of the mover (4), which are caused by temperature changes and/or by different materials with different coefficients of thermal expansion, are compensated.
6. The linear compressor (1) according to any one of claims 1-5, wherein the first wave retaining ring (8) is arranged and shaped to exert a compressive force on a wall (20) of the first groove (9) on a first side (21) of the magnet ring (5) upon movement of the mover (4) in a first direction or to exert a compressive force on the magnet ring (5) upon movement of the mover (4) in an opposite direction, wherein a reaction force is transmitted to a shoulder (22) of the yoke (6) on an opposite second side (23) of the magnet ring (5).
7. The linear compressor (1) according to any one of claims 1-6, wherein the second wave retaining ring (10) is arranged and shaped to exert a compressive force on a wall (24) of the second groove (11) on a first side (25) of the yoke (6) upon movement of the mover (4) in one direction or to exert a compressive force on the yoke (6) upon movement of the mover (4) in an opposite direction, wherein a reaction force is transmitted to a shoulder (26) of the cylinder (7) on an opposite second side (27) of the yoke (6).
8. Linear compressor (1) according to any one of claims 1-7, wherein the mover (4) is designed such that radial expansions or contractions of the components of the mover (4), namely the magnet ring (5), the yoke (6) and the cylinder (7), caused by temperature changes are compensated by radial gaps (28, 29) between the components of the mover (4).
9. Linear compressor (1) according to any one of claims 1-8, wherein a piston (12) is arranged within the cylinder (7), wherein a gas medium or a coolant is compressed by the oscillating movement of the cylinder (7) relative to the stationary piston (12) in a

chamber (13) between the piston (12) and the cylinder (7) and subsequently the compressed gas medium or coolant is discharged through an outlet valve in order to achieve the desired cooling effect.

5

10

15

20

25

30

35

40

45

50

55

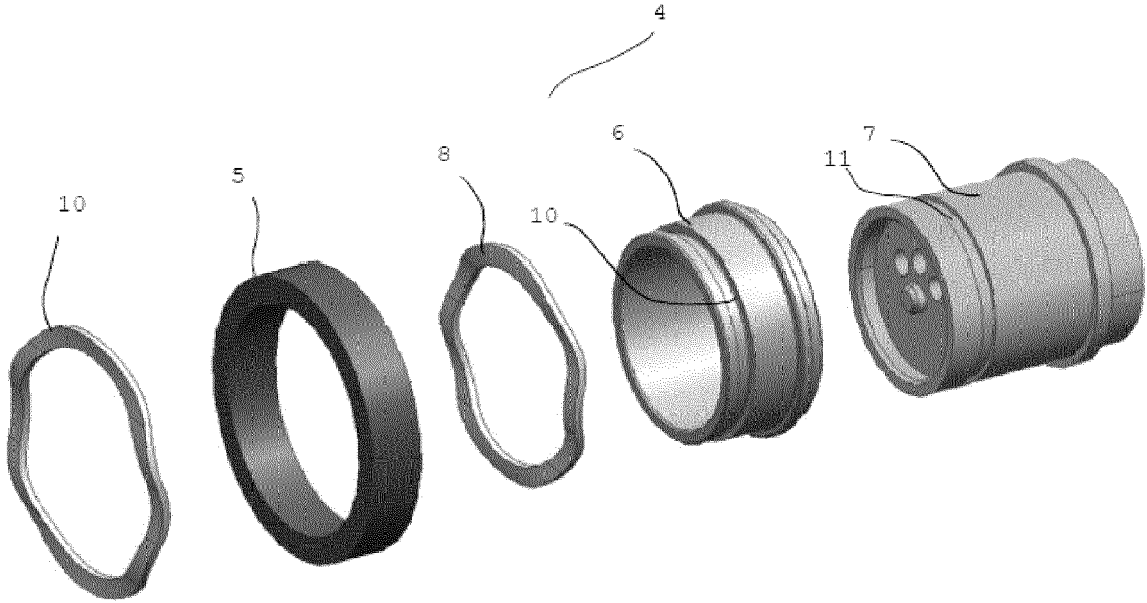

Fig. 3

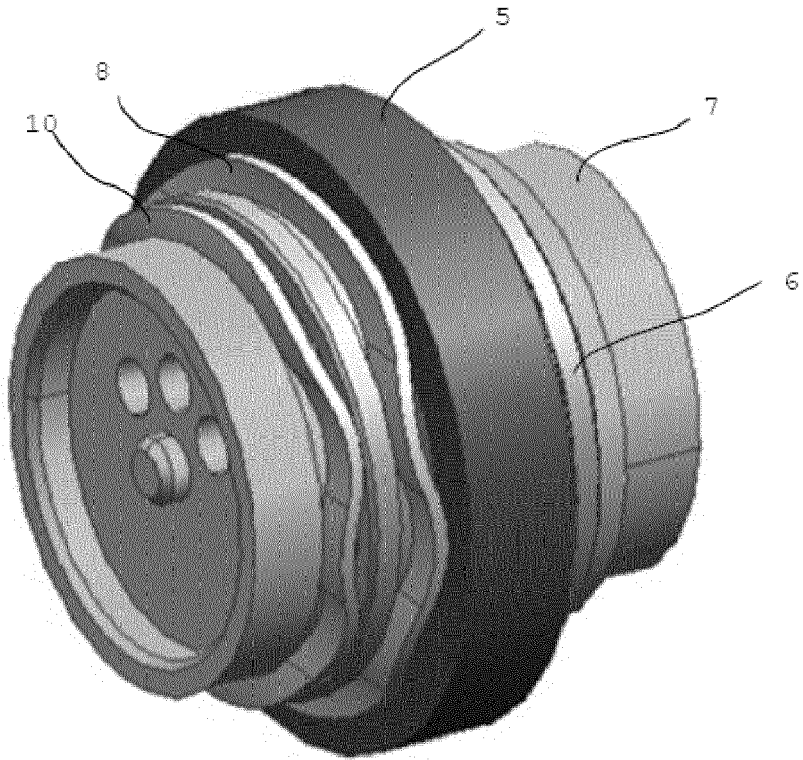

Fig. 4

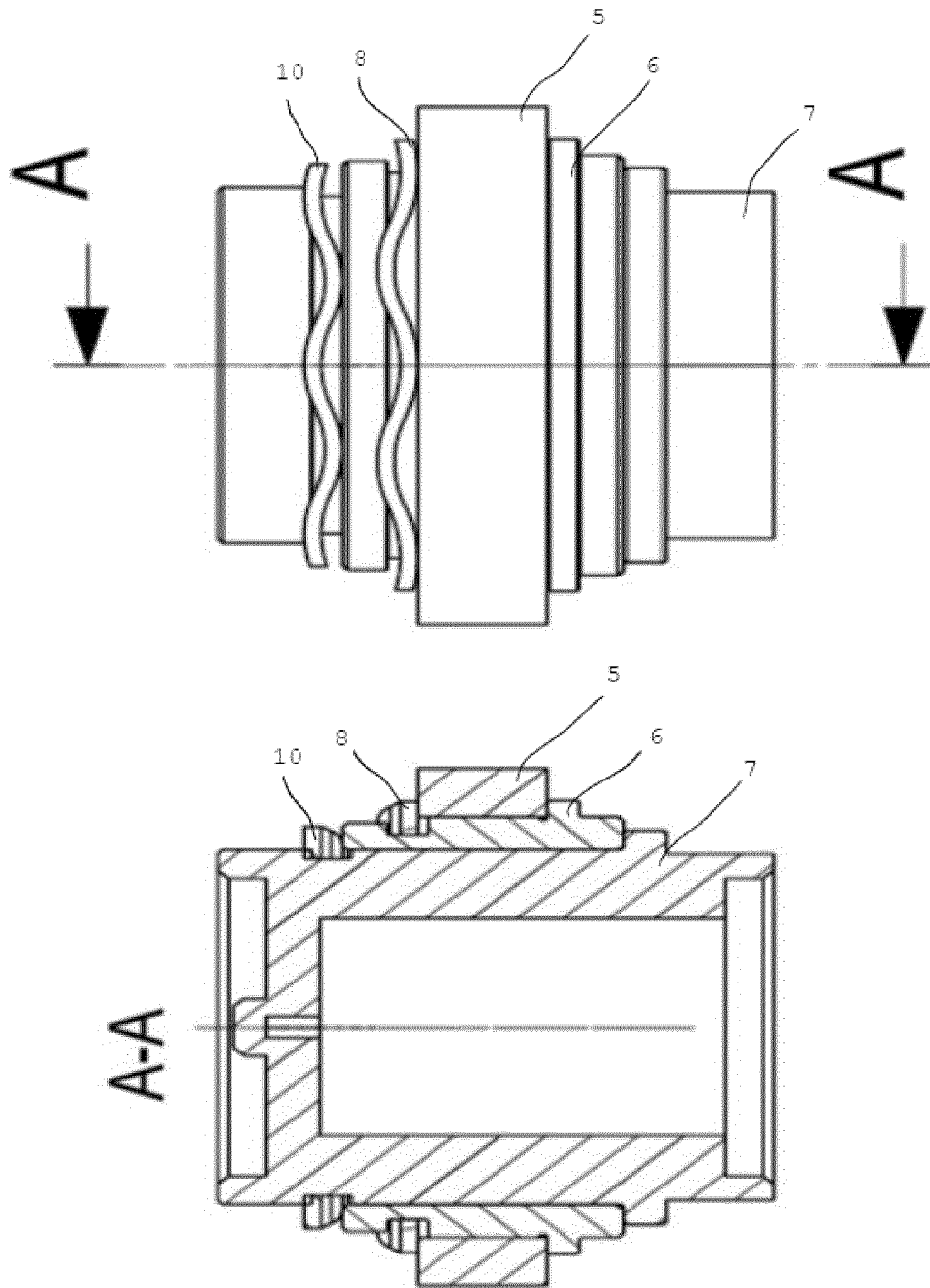

Fig. 5



EUROPEAN SEARCH REPORT

Application Number

EP 23 21 6496

5

10

15

20

25

30

35

40

45

50

55

DOCUMENTS CONSIDERED TO BE RELEVANT			
Category	Citation of document with indication, where appropriate, of relevant passages	Relevant to claim	CLASSIFICATION OF THE APPLICATION (IPC)
Y	US 2006/250032 A1 (HER JONG T [KR]) 9 November 2006 (2006-11-09)	1, 3, 4, 6-9	INV. F04B35/04
A	* paragraph [0046] * * figure 2 *	2, 5	
Y	----- KR 2009 0105469 A (LG ELECTRONICS INC [KR]) 7 October 2009 (2009-10-07)	1, 3, 4, 6-9	
A	* figure 1 *	2, 5	
A	----- US 7 078 832 B2 (MATSUSHITA REFRIGERATION [JP]) 18 July 2006 (2006-07-18)	1-9	
	* column 5, line 33 - line 52 * * figure 4 *		
A	----- US 9 488 165 B2 (CHO SUNGMAN [KR]; PARK JUNGSIK [KR] ET AL.) 8 November 2016 (2016-11-08)	1-9	
	* column 5, line 48 - column 6, line 4 * * figures 2, 3 *		
A	----- US 4 632 645 A (KAWAKAMI NAOYA [JP] ET AL) 30 December 1986 (1986-12-30)	1-9	TECHNICAL FIELDS SEARCHED (IPC)
	* column 7, line 37 - line 57 * * figure 10A *		F04B

The present search report has been drawn up for all claims			
Place of search Munich		Date of completion of the search 24 May 2024	Examiner Lange, Christian
CATEGORY OF CITED DOCUMENTS		T : theory or principle underlying the invention E : earlier patent document, but published on, or after the filing date D : document cited in the application L : document cited for other reasons & : member of the same patent family, corresponding document	
X : particularly relevant if taken alone Y : particularly relevant if combined with another document of the same category A : technological background O : non-written disclosure P : intermediate document			

EPO FORM 1503 03.82 (F04C01)

**ANNEX TO THE EUROPEAN SEARCH REPORT
ON EUROPEAN PATENT APPLICATION NO.**

EP 23 21 6496

5

This annex lists the patent family members relating to the patent documents cited in the above-mentioned European search report. The members are as contained in the European Patent Office EDP file on The European Patent Office is in no way liable for these particulars which are merely given for the purpose of information.

24-05-2024

10

15

20

25

30

35

40

45

50

55

Patent document cited in search report	Publication date	Patent family member(s)	Publication date
US 2006250032 A1	09-11-2006	BR PI0601110 A	19-12-2006
		CN 1858445 A	08-11-2006
		EP 1724466 A1	22-11-2006
		JP 4745768 B2	10-08-2011
		JP 2006312923 A	16-11-2006
		US 2006250032 A1	09-11-2006

KR 20090105469 A	07-10-2009	NONE	

US 7078832 B2	18-07-2006	AU 2003301464 A1	04-05-2004
		CN 1579044 A	09-02-2005
		DE 60310191 T2	20-09-2007
		EP 1450472 A1	25-08-2004
		KR 20040058253 A	03-07-2004
		US 2004251748 A1	16-12-2004
		US 2005244290 A1	03-11-2005
		WO 2004036723 A1	29-04-2004

US 9488165 B2	08-11-2016	CN 102792024 A	21-11-2012
		KR 20110103762 A	21-09-2011
		US 2013004343 A1	03-01-2013
		WO 2011115398 A2	22-09-2011

US 4632645 A	30-12-1986	AU 576642 B2	01-09-1988
		DE 3540957 A1	28-05-1986
		DE 3546605 C2	30-08-1990
		JP H0316512 B2	05-03-1991
		JP S61126385 A	13-06-1986
		US 4632645 A	30-12-1986

EPO FORM P0459

For more details about this annex : see Official Journal of the European Patent Office, No. 12/82

REFERENCES CITED IN THE DESCRIPTION

This list of references cited by the applicant is for the reader's convenience only. It does not form part of the European patent document. Even though great care has been taken in compiling the references, errors or omissions cannot be excluded and the EPO disclaims all liability in this regard.

Patent documents cited in the description

- US 8876497 B2 [0003]