

ORIGINAL

DISPOSABLE SINGLE USE BEVERAGE PACKAGE

ABSTRACT

A disposable single use beverage package is disclosed. The package may include an impermeable barrier surrounding a permeable single walled basket. The permeable basket may include a frame and a filter. The permeable basket may also include a lid. The permeable basket may be provided preloaded with beverage grounds or may be loaded with beverage grounds during use. The beverage packet may be manufactured of materials that are biodegradable, compostable, or otherwise environmentally friendly.

We Claim:

1. A disposable single use beverage package:
 - a disposable impermeable barrier configured to contain a disposable permeable basket;
 - the disposable permeable basket configured to contain beverage grounds; and
 - where the permeable basket comprises a frame and a filter material.
2. The disposable single use beverage package of claim 1, where the disposable permeable basket is a single-wall basket.
3. The disposable single use beverage package of claim 1, where the frame comprises a material selected from the group consisting of polystyrene, polyethylene, polypropylene, polylacticacid, polyhydroxyalkanoates, polyamide, polyester, and thermoplastic starch.
4. The disposable single use beverage package of claim 1, where the frame comprises a blend of materials selected from the group consisting of polystyrene, polyethylene, polypropylene, polylacticacid, polyhydroxyalkanoates, polyamide, polyester, and thermoplastic starch.

5. The disposable single use beverage package of claim 1, where the filter material comprises a non-woven or woven mesh material chosen from the group consisting of polystyrene, polyethylene, polypropylene, polylacticacid, polyhyrdoxyalkanoates, polyamide, polyester and thermoplastic starch.
6. The disposable single use beverage package of claim 1, where the disposable permeable basket is formed by insert injection molding of the frame around the filter medium.
7. The disposable single use beverage package of claim 1, where the disposable impermeable barrier is a tightly sealed wrap.
8. The disposable single use beverage package of claim 1, where the disposable impermeable barrier is a bag.
9. The disposable single use beverage package of claim 1, where the disposable impermeable barrier is a pouch.
10. The disposable single use beverage package of claim 1, where the impermeable barrier comprises a material selected from the group

consisting of foil laminate, metalized film, EVOH film, polyethylene, and other barrier plastic.

11. The disposable single use beverage package of claim 1, where the permeable basket includes a lid.

12. The disposable single use beverage package of claim 11, where the lid comprises a material selected from the group consisting of foil laminate, metalized film, EVOH film, polyethylene, and barrier plastic.

13. The disposable single use beverage package of claim 1, where the beverage grounds are coffee grounds.

14. A disposable single use beverage package:

a disposable permeable basket;

the disposable permeable basket comprises a frame and a filter material;

where the frame is configured to nest with a second permeable basket.

15. The disposable single use beverage package of claim 14, further comprising a removable lid.

16. The disposable single use beverage package of claim 14, wherein the removable lid comprises a material selected from the group consisting of foil laminate, metalized film, EVOH film, polyethylene, Nylon and polyester.

17. The disposable single use beverage package of claim 14, wherein the removable lid comprises at least one of a monolayer or a multilayer material.

18. The disposable single use beverage package of claim 14, wherein the filter material comprises a non-woven or woven material chosen from the group consisting of polystyrene, polyethylene, polypropylene, polylacticacid, polyhydroxyalkanoates, polyamide, polyester and thermoplastic starch.

19. The disposable single use beverage package of claim 14, where the frame comprises a material selected from the group consisting of polystyrene, polyethylene, polypropylene, polylacticacid, polyhydroxyalkanoates, polyamide, polyester, thermoplastic starch, and their injection moldable blend

20. A plurality of single use beverage packages according to claim
14 nested in a stack and sealed in an impermeable barrier.

Dated this 30th day of March 2012



Rohit Singh
IN/PA-1224

2750 DELNP 12

ORIGINAL

30 MAR 2012

APPLICANT: LBP MANUFACTURING, INC.

No. of Sheets: 7
Sheet No: 1

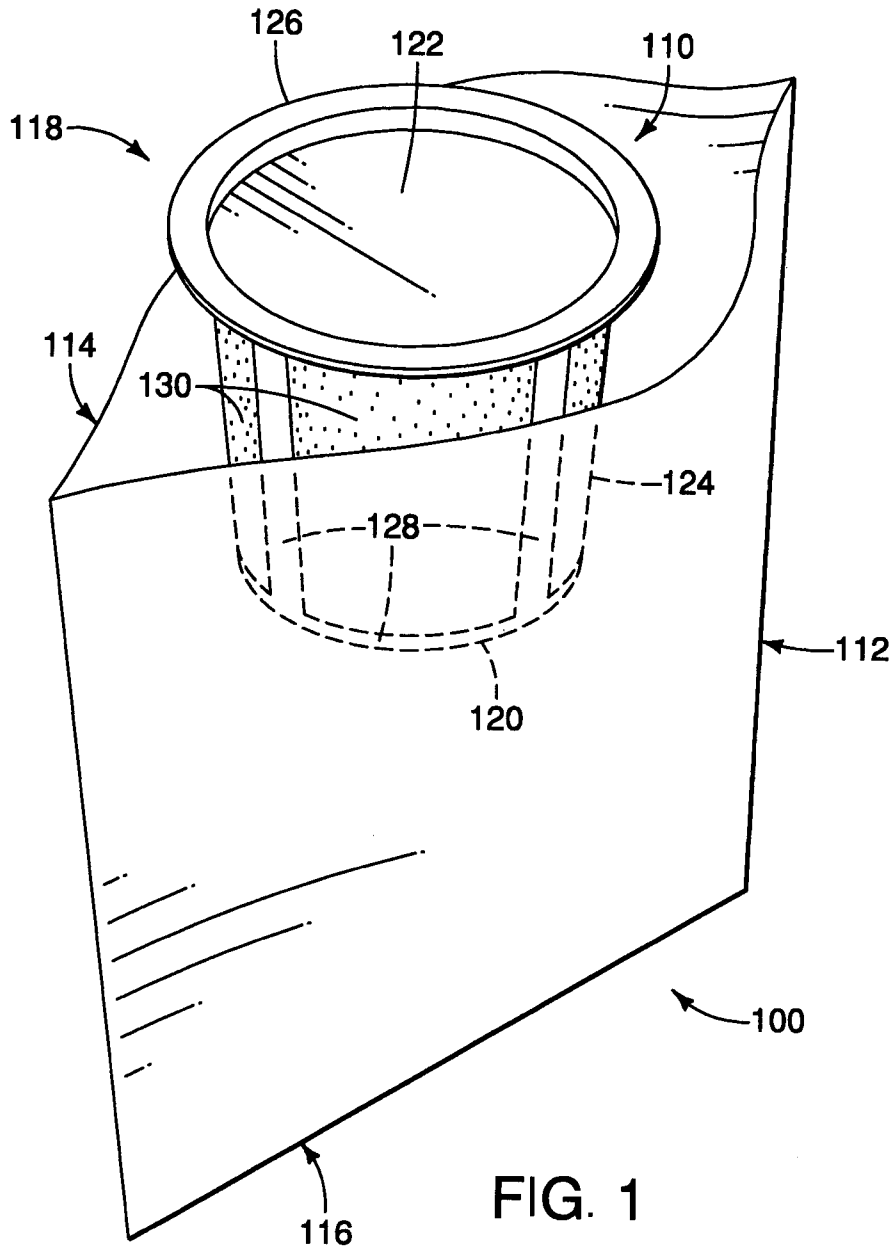

FIG. 1

Rohit Singh
Rohit Singh
Agent for the Applicant

ORIGINAL.

2750 DELP 12
30 MAR 2012

APPLICANT: LBP MANUFACTURING, INC.

No. of Sheets: 7
Sheet No: 2

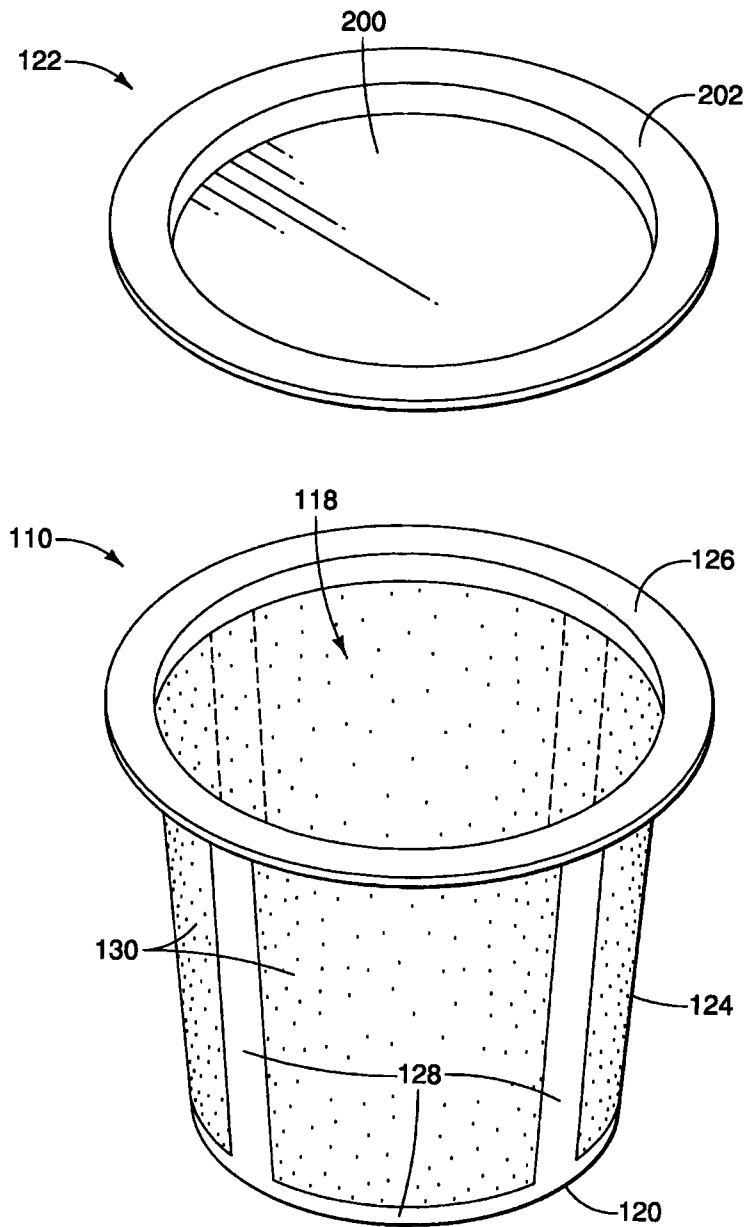

FIG. 2

Rohit Singh
Rohit Singh
Agent for the Applicant

2750 SEP 12

ORIGINAL

30 MAR 2012

APPLICANT: LBP MANUFACTURING, INC.

No. of Sheets: 7
Sheet No: 3

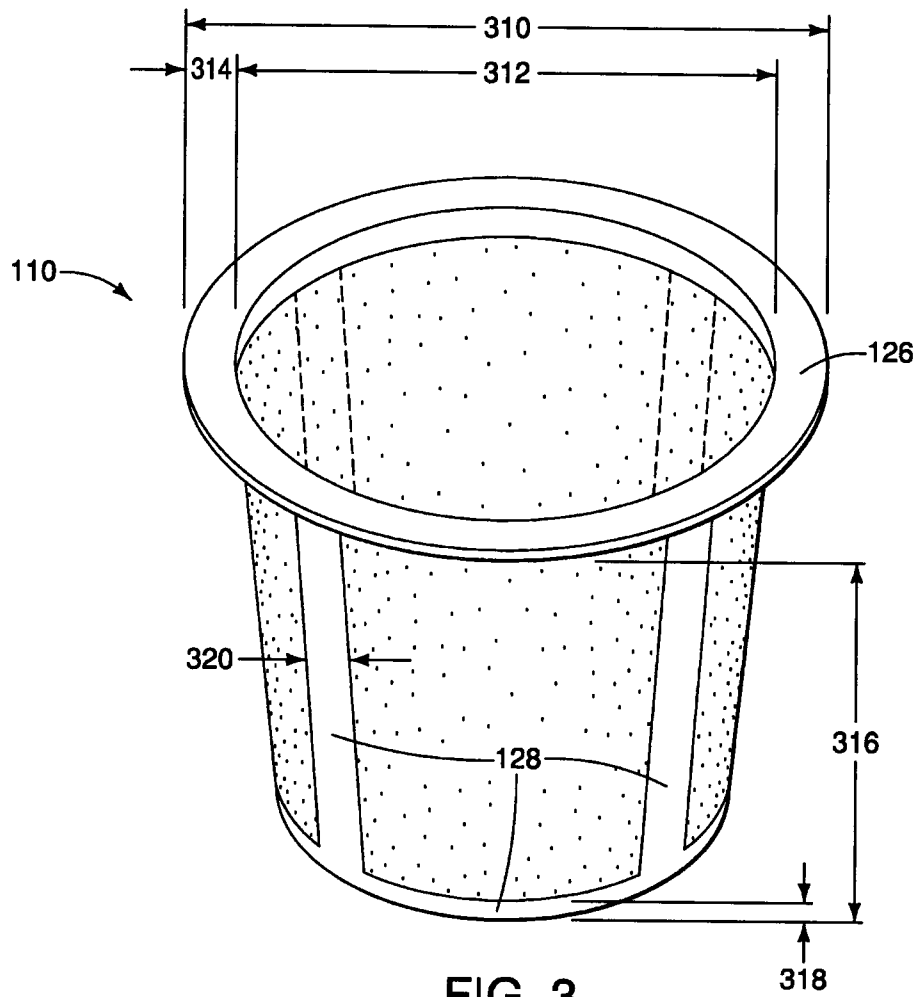

Rohit Singh
Rohit Singh
Agent for the Applicant

ORIGINAL

2750/12

30 MAR 2012

APPLICANT: LBP MANUFACTURING, INC.

No. of Sheets: 7
Sheet No: 4

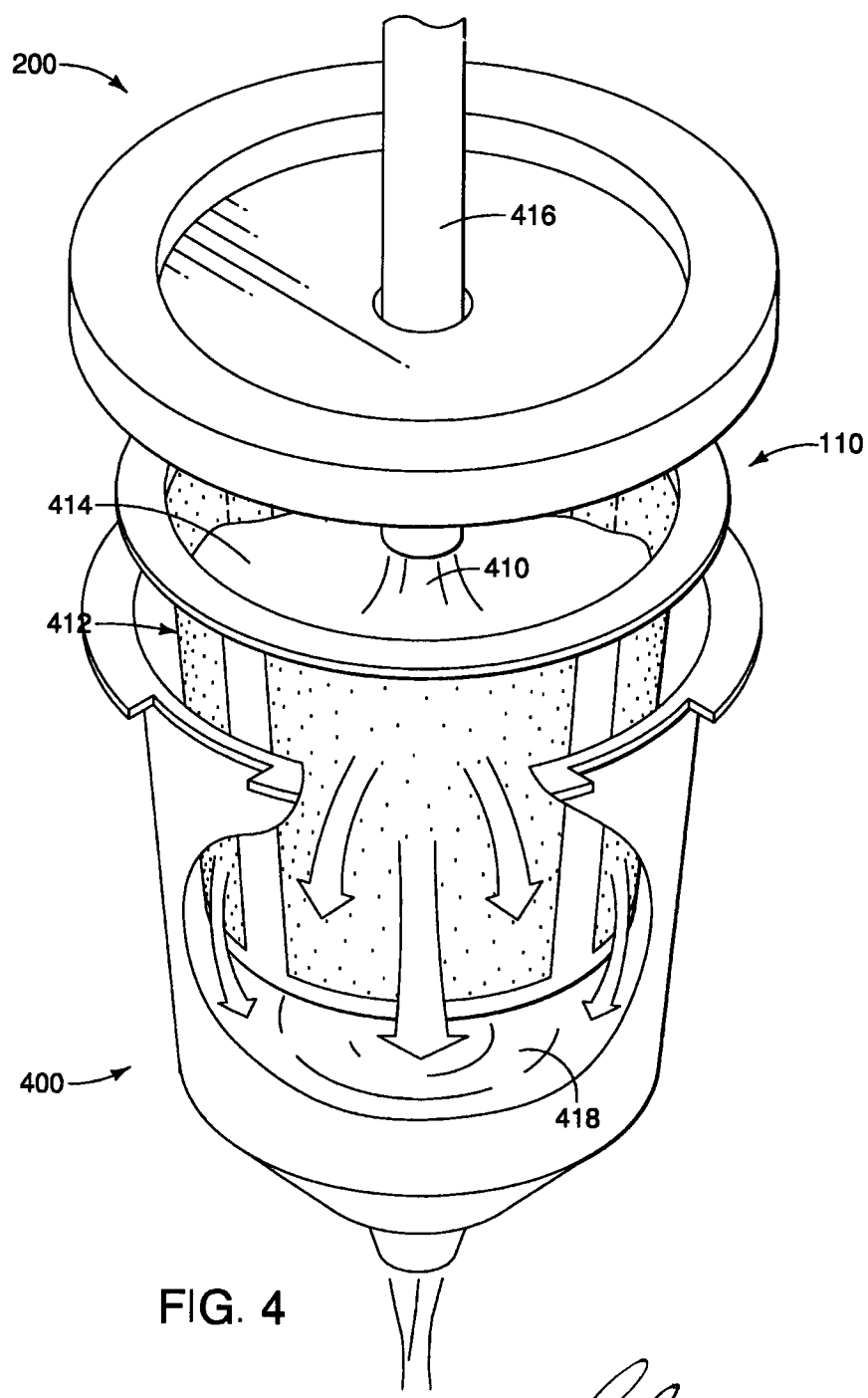

FIG. 4

Rohit Singh
Rohit Singh
Agent for the Applicant

ORIGINAL

2750 DELNP 12
30 MAR 2012

APPLICANT: LBP MANUFACTURING, INC.

No. of Sheets: 7
Sheet No: 5

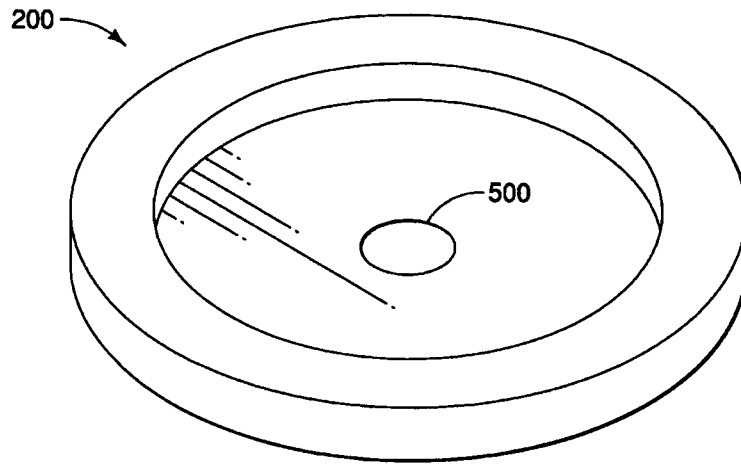

FIG. 5

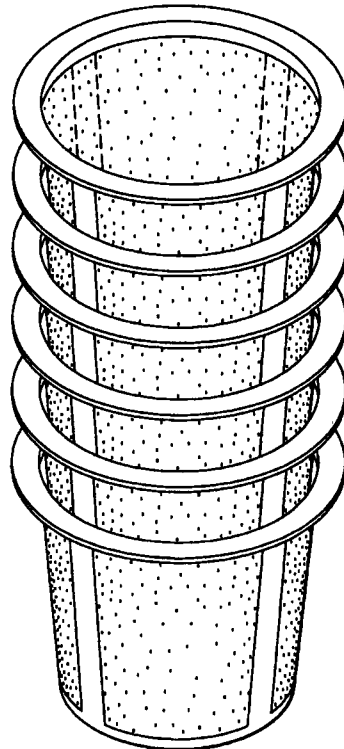

FIG. 6

Rohit Singh
Agent for the Applicant

ORIGINAL

2750 DELNP 12

30 MAR 2012

APPLICANT: LBP MANUFACTURING, INC.

No. of Sheets: 7
Sheet No: 6

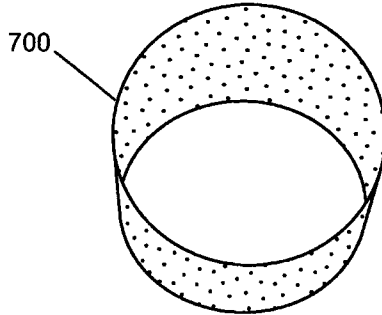

FIG. 7A

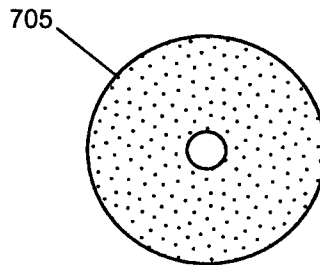

FIG. 7B

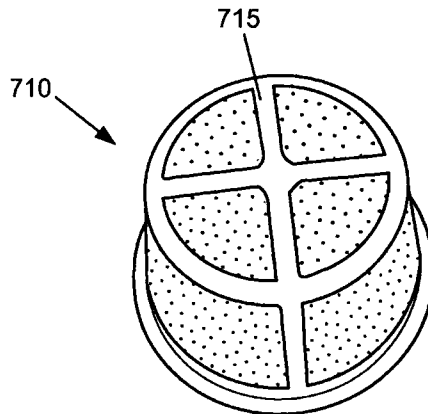

FIG. 7C

Rohit Singh
Agent for the Applicant

ORIGINAL

2750 DELNP 12

30 MAR 2012

APPLICANT: LBP MANUFACTURING, INC.

No. of Sheets: 7
Sheet No: 7

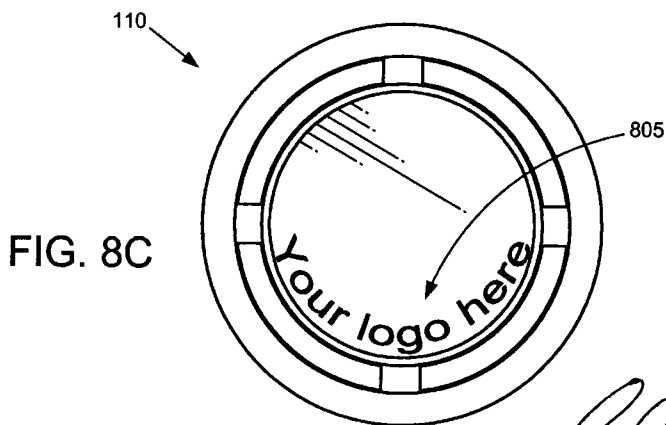
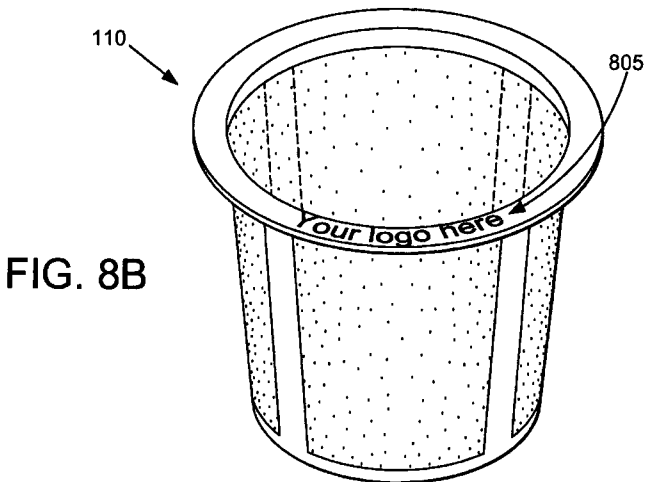
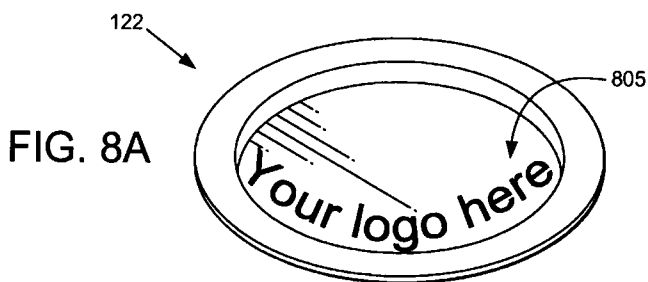

Rohit Singh
Rohit Singh
Agent for the Applicant

BACKGROUND

[0001] Single serve beverage brewing is popular among consumers. There are many formats of single serve brewers on the market. These brewers are designed to quickly brew a single cup of coffee or tea. The coffee or tea grounds are sold in prepared, single serving portions.

[0002] Reusable devices for single serve brewers, such as devices with metal or steal filters, may not suitable in some situations. For example, when efficiency is required such as in a busy home, in an office environment, or in a waiting-room environment. Reusable devices require cleaning, which may be complicated by the tendency of beverage grounds to cake into the filter openings. Additionally, to accommodate cleaning of reusable devices, the single serve brewer will be required to be placed near a source of water and a sink or drain. Provision of a sink or drain may be impracticable.

BRIEF SUMMARY

[0003] A disposable single use beverage package. The package may include a barrier, which may be an impermeable barrier surrounding a basket, which may be a permeable single walled basket. The basket may include a frame and a filter medium. The basket may also include a lid. The basket may be provided preloaded with beverage grounds or may be loaded with beverage grounds during use.

[0004] Other systems, methods, features and advantages of the invention will be, or will become, apparent to one with skill in the art upon examination of the following figures and detailed description. It is intended that all such additional systems, methods, features and advantages be included within this description, be within the scope of the invention, and be protected by the following claims.

BRIEF DESCRIPTION OF THE DRAWINGS

- [0005] Fig. 1 illustrates a disposable beverage portion basket with packaging.
- [0006] Fig. 2 illustrates a disposable beverage portion basket and lid.
- [0007] Fig. 3 illustrates a disposable beverage portion basket with exemplary dimensions.
- [0008] Fig. 4 illustrates use of a disposable beverage portion basket.
- [0009] Fig. 5 illustrates an exemplary lid for a disposable beverage portion basket.
- [0010] Fig. 6 illustrates an exemplary package of multiple disposable beverage portion baskets.
- [0011] Fig. 7A illustrates an exemplary filter medium side portion configured to be molded into a basket.
- [0012] Fig. 7B illustrates an exemplary filter medium bottom portion, if needed, configured to be molded to a bottom surface of a frame of a basket.
- [0013] Fig. 7C illustrates an exemplary filter side portion and filter bottom portion molded to a basket.
- [0014] Fig. 8A illustrates the placement of a logo on the exemplary lid.
- [0015] Fig. 8B illustrates the placement of a logo of the basket.
- [0016] Fig. 8C illustrates the placement of a logo on underside of the basket.

DETAILED DESCRIPTION OF THE DRAWINGS

[0017] Single serve beverage brewing is popular among consumers due to the convenience and flexibility that it provides. Many single serve beverage brewers have entered the market. Traditional brewers typically produce between four and twenty cups of beverage at a time. The beverage sits on a hot plate until it is consumed. As time passes,

the taste of the beverage may decline. Single serve brewing allows a consumer to enjoy beverages, such as coffee and tea, in an efficient fashion and without a decline in the taste profile of the beverage.

[0018] In Fig. 1, coffee or tea grounds for use in a single serving brewer may be packaged in a disposable single use beverage package **100**. A disposable single use beverage package **100** may include a basket **110**, which may be a permeable basket and barrier **112**, which may be a disposable impermeable barrier.

[0019] The barrier **112** may have a first side **114** and a second side **116**. The first side **114** may include a score, a tab, a zip, an embedded string, or otherwise provide a means for assisting a user to open the barrier **112**. The barrier **112** may be sealed at the second side **116** or other sides by gusseting, pinching, heat sealing, stapling, or otherwise. Alternatively or additionally, the barrier **112** may be a shrink wrap barrier or a wax barrier, among others.

[0020] The barrier **112** may be substantially resistant to the passage of liquids, gases, and solids. For example, the barrier **112** may be hermetically sealed to block moisture and oxygen from entering the pouch and to retain the aroma of the coffee. Additionally or alternatively, several baskets may be prefilled and packaged together in an egg crate type configuration, a tube, or other packaging, to maintain freshness during shipping and storing. The barrier **112** may be made of materials such as foil laminate, metalized films, EVOH films, polyolefin based material, parafilm, plastics, and combinations of these, among others.

[0021] A user may open the package **100**, for example, by tearing the barrier **112** along the first side **114** to reveal the basket **110**. The user may remove the basket **110** from the barrier **112** and place the basket **110** into a single serve brewer. The basket **110** may be prefilled

with grounds, or alternatively, the user may add grounds to the basket **110**.

[0022] The basket **110** may be a single-wall permeable basket including a first end **118**, which may be reversibly closed or an open end, and a second end **120**, which may be a closed end. The basket **110** may be a cup shaped basket and may be used with a lid **122**. The basket **110** may also have a side wall **124** and a rim **126**. The side wall **124** may connect the second end **120** and the rim **126**. The side wall **124** may include a frame **128** and a filter medium **130**.

[0023] The frame **128** may provide structure, stability, and integrity to the filter medium **130**. The frame **128** may be formed by injection molding or by a different process suitable for manufacturing a rigid form around a relatively flexible filter medium. The frame **128** may be made of any one of many commercially available materials, such as polystyrene, polyethylene, polypropylene, polyester, polyamide or Nylon, or other synthetic or natural plastics or combinations thereof. The frame may be made from other materials such as a bio-based polymer, such as polylactic acid (PLA), poly hydroxybutyric acid (PHA) or a starch based polymer. The frame **128** may be made of other materials known to those skilled in the art.

[0024] In Fig. 2, the side walls **124** of the basket **110** may be defined by the frame **128** and a filter medium **130**. The filter medium **130** may be secured to the basket **110**, for example, at the second end **120**, the rim **126**, and/or at that frame **128**. The filter medium **130** may be secured for example, by thermal bonding of the plastic used for the frame **128**, or with an adhesive, by crimping, by heat sealing, or any other way. The filter medium **130** may be secured in the frame **128** in insert-injection molding of the plastic frame around a filter medium insert. For example, a pre-die cut blank of filter medium may be placed on a mandrel which has channels around the shape of the pre die-cut

blank. Molten plastic may flow in and bond to the blank of the filter medium **130** during inert-injection molding. The plastic may solidify into the frame **128**, for example, upon cooling. Referring to Figs. 7A-7C, in an alternative embodiment the filter medium **700** and **705** may be first formed into a generally cylindrical and tapered portion **700** and an optional bottom circular filter medium **705** herein after referred to as the circular portion **705**. The filter medium **700** and **705** may then be placed or inserted onto a mold for insert injection molding to form the basket **710** with the filter media **700** and **705** supported by the frame of the basket **710**. The bottom end **715** of the frame of the basket **710** may be substantially open and a circular filter portion **705** may cover the open portions.

[0025] The filter medium **130** may be a porous material and may be permeable to liquids and some oils. It may be formed of many materials, for example, non-woven materials such as polystyrene, polyethylene, polypropylene, polylactic acid, cellulosic fibers, polyhydroxyalkanoates, thermoplastic starch, filter paper, other paper materials, polymer materials, a combination of these or any other material. The filter medium **130** may also be formed from a polymer or plastic filtration mesh, or microporous or apertured films made of various plastic materials, such as polypropylene, Nylon 6 and high density polyethylene or other materials known to those skilled in the art. Alternatively, the filter medium **130** may be formed from a bio-based polymer, such as polylactic acid (PLA), poly hydroxybutaric acid (PHA) or starch based polymer.

[0026] Characteristics of the filter medium **130** may be selected to meet the filtration needs of different products, such as ground coffee, tea powders or leaves, or other brewed products. For example, the basis weight, thickness, strand count, mesh size, flow rate and strength

of the filter medium **130** may be selected based on the product to be brewed.

[0027] The filter medium **130** may be compostable, biodegradable, recycled, and/or recyclable. If the filter medium **130** is a non-woven material, it may have a greater resistance than, for example, a woven material or a metal filter. A non-woven filter medium **130** may retain water in the basket for longer than, for example, a woven or metal filter. The length of time that the water is retained in the basket with the grounds may influence the strength and therefore the taste profile of the resulting beverage. This may be because a woven material or a metal material may have technological limitations on the size of the openings there through. A non-woven material may not have the same technological limitations. Therefore, the difference may be that, in a woven material or metal material, the path of the water may be straight through the wall and in the non-woven material, the path may be indirect and convoluted.

[0028] The basket **110** may include a lid **122**. The lid **122** may include a rim **202** and a cover **200**. The cover **200** may be disposed below the rim **202** for secure fitting with the basket **110**. Alternatively, the cover **200** may not include a rim **202**. The cover **200** may be made from a material that may be punctured to allow a liquid to enter into the basket. For example, the cover **200** may be a material, such as a foil, film, coated film, or multilayer laminate, which is sealed to or across the rim **126** of the permeable basket **110** to maintain contents therein. The cover **200** may keep dry contents dry, wet contents wet, and may maintain a freshness of the contents. The cover **200** may be formed of a plastic, metallic foil, filter material, thermoplastic starch, or a laminate or composite thereof.

[0029] The basket **110** may be dimensioned for use with a commercial single serve coffee brewer. Fig. 3 shows an exemplary

basket **110**. The basket **110** may have width of the open end **312**, and a height **316**. The open end **312** may be, for example but not limited to, about 38-42mm. The height **316** may be, for example but not limited to, 38-42mm. The rim **126** may have a dimension **314** of, for example but not limited to, 3.5-5.5mm. The frame **128** may have a dimension **320** of, for example but not limited to, 5mm, and a dimension **318** of, for example but not limited to 2mm. These dimensions are merely exemplary and not limiting. The basket **110** may also have other dimensions or shapes, for example, dimensions that permit use in various single serve beverage machines.

[0030] In Fig. 4, a basket **110** may be prefilled with beverage grounds **414**, for example but not limited to, coffee or tea grounds. Alternatively or additionally, the basket **110** may be loaded with beverage grounds **414** immediately prior to use. If the basket **110** is prefilled with beverage grounds **414** it may be sealed with a lid **122**. Alternatively, if the permeable basket **110** is not preloaded with beverage grounds **414**, it may not have a lid **122**, additionally or alternatively; it may have a removable lid **122**, or otherwise.

[0031] During use, a user may open the barrier **112**, take out the basket **110** and place the basket **110** into a single serve beverage machine. A heated liquid **410** may be received by the basket **110** through an opening in the cover **200** or otherwise. For example, during use, a preloaded basket **110** may be placed inside a cartridge **400** for a single serve beverage machine. The cartridge **400** may be reusable or disposable. During a brewing cycle, the cover **200** may be pierced by a probe **416** to admit heated liquid **410** into the basket **110**. The heated liquid may interact with the beverage grounds **414** creating a beverage medium. The beverage medium **418** may flow through the filter medium **130** and exit through an opening in the cartridge **400**.

[0032] As a second example, during use, an unloaded permeable basket **110** may be placed inside a cartridge **400** for a single serve beverage machine. The cartridge **400** may be reusable or disposable. The beverage grounds **414** may be placed into the basket **110**. A cover **200** may be attached to maintain the contents of the basket **110**. During a brewing cycle, the cover **200** may be pierced by a probe **416** to admit heated liquid **410** into the basket **110**. The heated liquid may interact with the beverage grounds **414** creating a beverage medium. The beverage medium **414** may flow through the filter medium **130** and exit through an opening in the cartridge **400**. Alternatively, no cover **200** may be required. In this case, the heated liquid **410** will flow directly into the basket **110**.

[0033] Fig. 5 illustrates one example of a lid **122** for a basket **110**. The cover **200** of the lid **122** may include an opening **500** for entry of a liquid probe. The opening **500** may be a weakened portion of the material of the cover **200** which may give easily under the pressure of a probe.

[0034] In Fig. 6, unloaded tapered baskets **110** may be configured for efficient nesting. The baskets **110** may be sold nested in a stack or tube, which may be packed in a sleeve of plastic film, or otherwise. The unloaded basket **110** may allow the end user to select a variety of beverage grounds **414** for use in their single serve brewer. The end user may also be able to modify the amount of beverage grounds **414** for use in their single serve brewer.

[0035] The components of the single use beverage package **100** may be selected with the intention of creating an environmentally friendly product. For example, the filter medium **130** may be made from a range of synthetic or biodegradable, recycled or recyclable, or compostable materials such as polyolefins, polylactic acid, cellulose, polyhydroxyalkanoates, thermoplastic starch, a combination of these or

other materials. The basket frame **128** material, cover **200** and barrier **112** may also be made out of these materials or similar synthetic, biodegradable, recycled or recyclable, or compostable materials which retain the properties of structural integrity (e.g., frame **128**) and impermeability (e.g., barrier **112**).

[0036] While various embodiments of the embodiments have been described, it will be apparent to those of ordinary skill in the art that many more embodiments and implementations are possible that are within the scope of the claims. For example, referring to Figs. 8A-8C, logos 805 of various configurations may be placed on the lid **122 (Fig. 9A)**, the basket **110 (Fig. 8B)**, or the underside of the basket **110**. The logos 805 may also be printed on the filter medium 130. The logos 805 enable a vendor to, for example, place descriptive information about the product that is in the basket, such as whether the product is coffee or tea, a type of blend, and the like. Other information known to those skilled in the art may also be printed.

[0037] Accordingly, it will be apparent to those of ordinary skill in the art that many more embodiments and implementations are possible that are within the scope of the claims. Therefore, the embodiments described are only provided to aid in understanding the claims and do not limit the scope of the claims.