

COMMONWEALTH OF AUSTRALIA

PATENTS ACT 1952

DECLARATION IN SUPPORT OF CONVENTION OR NON-CONVENTION APPLICATION FOR A PATENT

In support of the Application made for a patent for an invention entitled: DEVICE FOR THE SELECTIVE DETECTION OF OBJECTS

Insert title of invention.

Insert full name(s) and address(es) of declarant(s) being the applicant(s) or person(s) authorized to sign on behalf of an applicant company.

I
We

Arne Lundquist of Saab-Scania AB, S-581 86 LINKÖPING, SWEDEN,

Cross out whichever of paragraphs 1(a) or 1(b) does not apply
1(a) relates to application made by individual(s)
1(b) relates to application made by company; insert name of applicant company.

do solemnly and sincerely declare as follows :-

1. (a) ~~I am the applicant for the patent~~
We are

or (b) I am authorized by

SAAB MISSILES AKTIEBOLAG

Cross out whichever of paragraphs 2(a) or 2(b) does not apply

the applicant..... for the patent to make this declaration on ~~their~~ its behalf.

2. (a) ~~I am the actual inventor of the invention~~
We are

or (b)

LUNDIN, Jan-Erik of

Persikogatan 206
S-421 56 VÄSTRA FRÖLUNDA
SWEDEN

is the actual inventor..... of the invention and the facts upon which the applicant.....
is entitled to make the application are as follows :-

The inventor made the invention during the course of his employment with the applicant, whereby the applicant would if a patent were granted upon an application made by the said actual inventor, be entitled to have the patent assigned to it.

3. The basic application..... as defined by Section 141 of the Act ^{was} made ~~was~~ in Sweden..... on the 29th of May 1987 by SAAB MISSILES AKTIEBOLAG in..... on the..... by..... in..... on the..... by.....

4. The basic application..... referred to in paragraph 3 of this Declaration ^{was} the first application..... made in a Convention country in respect of the invention the subject of the application.

Declared at Linköping this 3rd day of October 1989

Arne Lundquist
Arne Lundquist

Insert place and date of signature.

Signature of declarant(s) (no attestation required)

Note: Initial all alterations.

(12) PATENT ABRIDGMENT (11) Document No. AU-B-19353/88
(19) AUSTRALIAN PATENT OFFICE (10) Acceptance No. 610202

(54) Title
DEVICE FOR SELECTIVE DETECTION OF OBJECTS

International Patent Classification(s)
(51)⁴ G01S 003/78 G01C 003/08

(21) Application No. : 19353/88 (22) Application Date : 27.05.88

(87) WIPO Number : WO88/09513

(30) Priority Data

(31) Number (32) Date (33) Country
8702247 29.05.87 SE SWEDEN

(43) Publication Date : 21.12.88

(44) Publication Date of Accepted Application : 16.05.91

(71) Applicant(s)
SAAB MISSILES AKTIEBOLAG

(72) Inventor(s)
JAN-ERIK LUNDIN

(74) Attorney or Agent
DAVIES & COLLISON, 1 Little Collins Street, MELBOURNE VIC 3000

(56) Prior Art Documents
EP 146428
EP 41115
EP 14825

(57) The evaluation unit 2 is drawn in figure 8 in the form of a block diagram. In it a memory 30 is included, which in this connection is called image memory, a filter 31, a threshold calculator 32, a comparing means 33 and a target memory 34. Via the sensor unit the digital signals from the detector elements are available. In the image memory 30, different combinations of digital signals from the detector elements are stored temporarily, according to a certain sequence, thus representing different parts of the scanned angular range, in such a way, that during a scanning cycle, the signals from all the parts of the scanning range can be processed by the filter 31, which calculates, in a manner, in itself known, the difference between the signal intensity in a chosen direction and the signal intensity in the area surrounding it, area by area of the scanned range.

CLAIM

1. A device for the selective detection of objects, such as aircraft, missiles, helicopters and alike, by means of outgoing rays from the objects, comprising at least one sensor unit, whereby the sensor unit comprises at least one focusing means arranged to focus said rays to at least one corresponding focal plane, whereby the sensor unit is equipped with at least one radiation sensitive detector element which is positioned in the focal plane, which detector element is arranged to emit signals corresponding to the incoming radiation, whereby the device includes at least two optical entrances so as to be capable of receiving the rays at two distinct points at a relative distance across a line of sight from the device to the object and is arranged to variably scan an angular field in azimuth and/or elevation, whereby the device further comprises an evaluation unit, arranged to receive said signals, characterised in that the evaluation unit is arranged to select objects which seem to be of similar size with respect to the angle measured from the position of the device, in on the one hand large objects being at a long distance, such as aircraft etc., and on the other and small objects being at a short distance, such as birds etc., by suppressing signals whose amplitude as a function of the scanned azimuth or elevation angle shows a relatively great extension compared with signals that show a relatively small extension.

PCT

AU-AI-19353/88

WORLD INTELLECTUAL PROPERTY ORGANIZATION
International Bureau



610202

INTERNATIONAL APPLICATION PUBLISHED UNDER THE PATENT COOPERATION TREATY (PCT)

(51) International Patent Classification 4 :

G01S 3/78, G01C 3/08

A1

(11) International Publication Number:

WO 88/ 09513

(43) International Publication Date: 1 December 1988 (01.12.88)

(21) International Application Number: PCT/SE88/00291

(22) International Filing Date: 27 May 1988 (27.05.88)

(31) Priority Application Number: 8702247-1

(32) Priority Date: 29 May 1987 (29.05.87)

(33) Priority Country: SE

(71) Applicant (for all designated States except US): SAAB MISSILES AKTIEBOLAG [SE/SE]; S-581 88 Linköping (SE).

(72) Inventor; and

(75) Inventor/Applicant (for US only) : LUNDIN, Jan-Erik [SE/SE]; Persikogatan 206, S-421 56 Västra Frölunda (SE).

(74) Agent: LUNDQUIST, Arne; Saab-Scania AB, Patentavdelningen, S-581 88 Linköping (SE).

(81) Designated States: AT (European patent), AU, BE (European patent), CH (European patent), DE (European patent), DK, FI, FR (European patent), GB (European patent), IT (European patent), JP, LU (European patent), NL (European patent), NO, SE (European patent), US.

Published

With international search report.

With amended claims.

In English translation (filed in Swedish).

A.O.J.P. 23 FEB 1989

AUSTRALIAN

21 DEC 1988

PATENT OFFICE

... amendments made and ... section 49 and is correct for printing

(54) Title: DEVICE FOR THE SELECTIVE DETECTION OF OBJECTS

(57) Abstract

A device for the selective detection of objects, such as aircraft, missiles, helicopters and alike, by means of outgoing rays from the objects, preferably IR-rays, comprises at least one sensor unit (1). The device comprises at least two optical entrances at a distance relative to each other across a sight line from the device to the object. The sensor unit (1) comprises at least one focusing means (15) for focusing the rays to a focal plane. The sensor unit is equipped with at least one radiation-sensitive detector element (16) arranged to emit signals corresponding to the radiation. The device is arranged to variably scan an angular field in azimuth and/or elevation. The device further comprises an evaluation unit (2) arranged to receive said signals. The invention is characterized particularly in that the evaluation unit (2) is arranged to select objects which seem to be of similar size with regard to the angle measured from the position of the device, in on one hand large objects being at a long distance, such as aircraft etc., and on the other hand small objects being at a short distance, such as birds, by suppressing signals whose amplitude as a function of the scanned azimuth or elevation angle shows a relatively great extension compared with signals which show a relatively small extension.

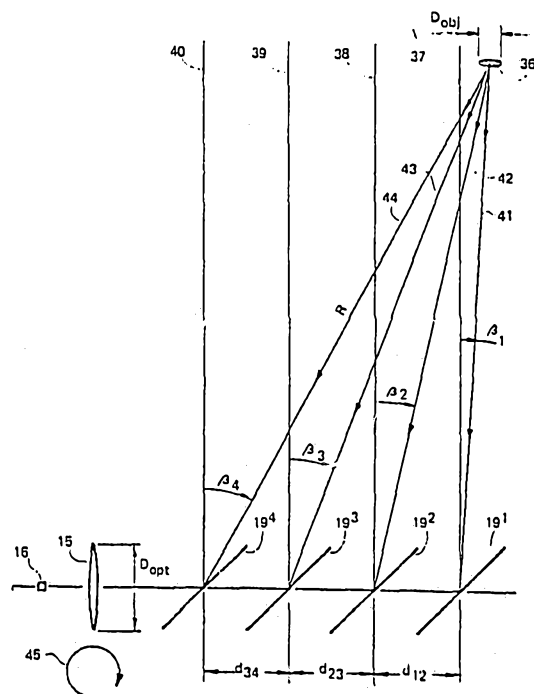

DEVICE FOR THE SELECTIVE DETECTION OF OBJECTS

The present invention relates to a device for the selective detection of objects, such as aircraft, missiles, helicopters and alike, by means of outgoing rays from the objects, preferably IR-rays, comprising at least one sensor unit, whereby the device
5 is arranged to receive the outgoing rays through at least two optical entrances arranged at a relative distance across a sight line from the device to the object, whereby the sensor unit comprises at least one focusing means arranged to focus said rays to at least one corresponding focal plane, whereby
10 the sensor unit is equipped with at least one radiation-sensitive detector element being positioned in a focal plane, which detector element is arranged to emit signals corresponding to the incoming radiation, whereby the device is arranged to variably scan an angular field in azimuth and/or elevation, whereby the device
15 further comprises an evaluation unit, arranged to receive said signals.

The invention is based on already known technique, which will here be described briefly.

On the market there is a device, a so-called scanner, intended
20 for detecting flying objects by means of IR-rays emitted from the objects. Such a scanner comprises a sensor unit, an evaluation unit and a display and control unit. The sensor unit receives IR-rays from the objects to be detected within the momentarily scanned solid angle. The sensor unit transmits the correspond-
25 ing signals to the evaluation unit, which processes the signals and upon the significant detection of objects, i.e. in a military context, targets, transmits the corresponding signals including direction coordinates to the display and control unit. From it the collected output data go, which in a military con-
30 text partly takes the form of a visible picture on a screen, and partly the form of signals, intended to be forwarded online and e.g. be used for guiding a fire-control system for anti-aircraft defence.

The evaluation unit has as its purpose to select those signals, among the signals received from the sensor unit, which are significant, i.e. which indicate targets within the scanning range of the sensor unit, and to indicate when such targets appear, and generally to indicate their coordinates. The evaluation unit functions thus according to beforehand chosen and programmed criteria of what will be considered significant objects, i.e. targets.

One way of regarding the functions of the evaluation unit is to separate them into filter function and decision function. The filter starts from the signals which are received from the sensor unit (measured intensity as a function of direction), and is designed to enhance the typical signals of targets. During filtering the direction information is kept. One can say that the filter output signal for a certain direction is a measure of the probability that there is a target in the actual direction.

A concrete example is a filter, which for every direction forms the difference between measured intensity in the actual direction and the average intensity in a two-dimensional interval of the surrounding directions. Typical for a filter in this application is particularly that the output signal for a certain direction is a weighted sum of the input signals of the filter in an angular range in and about that direction.

In a scanner whose purpose is to select significant objects, i.e. targets, in addition to the filter, a decision function is also required. That function is needed to decide, whether a significant object exists or not. The most common decision function is to compare the output signal of the filter with a threshold level. If that is exceeded, a significant object, i.e. a target, is indicated. The mechanism which chooses the threshold level may also be included in the decision function. The threshold level is often determined through some kind of statistical evalu-

ation of the output signals of the filter within a large range, possibly the whole scanning range. The aim is to find a level which is exceeded at an acceptably low frequency in the absence of significant objects, i.e. targets (false-alarm frequency) and
5 which yet is not too high for appearing targets to be indicated with certainty.

Scanners of the type just described function preferably within the IR-spectral ranges 3 to 5 and 7 to 13 micrometer, respectively, which represent "windows" with regard to the transmission
10 spectra of the atmosphere for IR-radiation. That means, that the focusing means of the sensor unit, which in itself can consist of a lens or mirror, usually consists of a silicon lens for the 3 to 5 micrometer range and a germanium lens for the 7 to 13 micrometer range, i.e. it is chosen with respect to the actual
15 spectral range. In view of hitherto existing corresponding radiation-sensitive detector elements, such a lens must be made comparatively large, in order that the sensor unit will produce signals such that the evaluation unit can detect significant targets with any appreciable precision.

20 Such a scanner cannot distinguish between birds (= insignificant objects) at a relatively close distance and aircraft (= significant objects) at a longer distance), which means that such birds could cause a false alarm which is a great disadvantage in hitherto known scanners of the kind described in the intro-
25 duction.

The purpose of the present invention is therefore to design a device of the kind mentioned by way of introduction, so as to make it possible to distinguish between relatively close objects from which radiation is emitted, and such objects which are
30 located at a longer distance, but which objects when observed subtend a similar solid angle.

~~According to the invention such a device is characterized in that the evaluation unit is arranged to select objects which~~



According to the present invention there is provided a device for the selective detection of objects, such as aircraft, missiles, helicopters and alike, by means of outgoing rays from the objects, comprising at least one sensor unit, whereby the sensor unit comprises at least one focusing means arranged to focus said rays to at least one corresponding focal plane, whereby the sensor unit is equipped with at least one radiation sensitive detector element which is positioned in the focal plane, which detector element is arranged to emit signals corresponding to the incoming radiation, whereby the device includes at least two optical entrances so as to be capable of receiving the rays at two distinct points at a relative distance across a line of sight from the device to the object and is arranged to variably scan an angular field in azimuth and/or elevation, whereby the device further comprises an evaluation unit, arranged to receive said signals, characterised in that the evaluation unit is arranged to select objects which seem to be of similar size with respect to the angle measured from the position of the device, in on the one hand large objects being at a long distance, such as aircraft etc., and on the other and small objects being at a short distance, such as birds etc., by suppressing signals whose amplitude as a function of the scanned azimuth or elevation angle shows a relatively great extension compared with signals that show a relatively small extension.



25

30



~~seem to be of similar size with respect to the angle measured~~
from the position of the device, in on one hand large objects
being at a long distance, such as aircraft etc., and on the
other hand small objects being at a short distance, such as
5 birds etc., by suppressing signals whose amplitude as a function
of the scanned azimuth or elevation angle shows a relatively
great extension compared with signals which show a relatively
~~small extension.~~

In one embodiment of the device according to the invention
10 the device comprises at least two sensor units, having their
optical entrances for the outgoing rays from the objects at
a relative distance across said sight line. In this case each
sensor unit functions in itself as a complete unit. Naturally,
a corresponding signal processing in the evaluation unit is
15 required, i.e. the signals from the sensor units shall be added
before effecting further signal processing in the evaluation
unit. It is suitable to design a sensor unit so, that each
optical entrance comprises a deflection means, preferably a
mirror, arranged to deflect the incoming rays of the entrance
20 to the corresponding focusing means. If one mirror per optical
entrance is used as a deflection means, the mirrors used must
naturally be so arranged that the radiation from each mirror,
usually positioned at an angle of 45° to the incoming rays,
can in fact reach the focusing means. That can be done through
25 an arrangement being such that the aperture of the optical
entrances are so displaced not only in one dimension relative
to said sight line, which is a condition for the function of
the device, but also in a second dimension perpendicular to
the former dimension. It is also conceivable to use mirrors
30 which are partly transparent to the actual radiation. If it
is desired to have the optical entrances arranged in two groups,
one on each side of the focusing means, an extra mirror per
group may be arranged to guide the radiation, which is trans-
mitted from the group, to the focusing means. That is usually
a lens, as in the case of IR-radiation made of e.g. germanium,

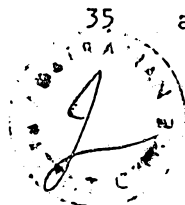

but concave mirrors are also possible, e.g. according to the Cassegrain-system. Other deflection means can be used, such as prisms arranged to totally reflect the incoming rays. The optical axes of the optical entrances shall be parallel.

- 5 The device according to the invention can, under certain circumstances, be applied with one single detector element, but it might be suitable to use a so-called array consisting of a number of detector elements arranged in a row. Such detector elements can also be arranged in a plane, i.e. two-dimensionally.
- 10 The device can be designed so as to be able to scan a small or large solid angle in azimuth and elevation. The detector elements of the sensor unit, either one single or several elements arranged either as a one-dimensional or two-dimensional array, call for different arrangements for widening the viewed
- 15 angle in azimuth or elevation.

In a suitable embodiment of the device according to the invention the device is as a whole rotatable about an essentially vertical axis, whereby a number of optical entrances are arranged at a distance from said axis, across the sight line toward

20 an imaginary object. The device is further movable in elevation, e.g. step-by-step, so that it e.g. rotates once about in every chosen elevation position. The movement in elevation can alternatively be continuous.

The scanning range can be arbitrarily large or small, provided

25 that the scanning can be effected across the object in at least one direction which lies tolerably well within the plane where the object and at least two optical entrances are situated.

Naturally, an angle position transducer for azimuth and elevation is required, which emits a position signal to the evaluation unit for every instantaneous measuring direction.

30

Instead of rotating the device it can be made to move e.g. forward and backward.

It is further possible to let the device as a whole be immobile and instead let the sensor unit or, where appropriate, the sensor units comprise an optical scanning means, arranged to variably scan an optic angle, in addition to the angle which is scannable with the corresponding detector element, in azimuth and/or elevation. One way of achieving that is to arrange said deflection means, e.g. the mirrors, to be movable. In an extreme case a sensor unit can be arranged with one single detector element, having a scanning means, such as a mirror functioning as a deflection means, which mirror is movable about two axes perpendicular to each other. Such an arrangement, however, should have a limited practical applicability, even with a corresponding evaluation unit. In such a device, a better performance can be achieved, if the detector elements are arranged as an area array, i.e. two-dimensionally.

In a preferred embodiment of the invention it comprises optical entrances, arranged in groups. These groups can suitably comprise two optical entrances each. The distance between the optical entrances in a group will thus be shorter than the distance between two optical entrances belonging to different groups. Through such an arrangement a further suppressing of signals which originate from comparatively small, comparatively close objects is achieved, which will be shown.

The invention will now be described more in detail with reference to the accompanying figures, which relate to an example of one embodiment of the device, i.e. a scanner designed for military use with the aid of IR-technique. On the drawings show:

figure 1 a block diagram of the scanner,

figure 2 a perspective view of the sensor unit in the scanner,

figure 3 the optical arrangement of the sensor unit,

figure 4 focusing means + detector elements,

figure 5 an array of detector elements, linear,

figure 6 an outline diagram of the scanning method of the device,

figure 7 a block diagram of the sensor unit,

figure 8 a block diagram of the evaluation unit,

5 figure 9 a sensor head, diagrammatically seen from above,

figure 10 signal amplitude via the four optical entrances in figure 9 as a function of the azimuth angle,

figure 11 a detector output signal with four and one optical entrance, respectively,

10 figure 12, 13, 14 a detector and filter output signal with four and one optical entrances, respectively, with the distances 500 m, 130 m and 10 km, respectively,

fig 15 and 16 a, b show diagrammatically the function of a filter.

15 In figure 1, 1 designates a sensor unit, 2 an evaluation unit and 3 a display and control unit. IR-rays received from objects within the scanning range are designated by 4, the corresponding signals from the sensor unit to the evaluation unit by 5 and the evaluated signals for significant objects
20 by 6, transmitted to the display and control unit 3. The collected output data of this unit is designated by 7, which can take the form of a visible picture on a screen and also signals for e.g. guiding a fire-control system for anti-aircraft defence. The connection designated by 8 transmits starting
25 and stopping commands etc.

The sensor unit in figure 2 comprises a sensor head with apert-

ures 10 to four optical entrances. The sensor head is suspended from an elevation servo 11, for a step-by-step adjustment into different elevation angles by turning about a horizontal axis. The elevation servo 11 is rigidly connected with a vertical
5 axis 12, supported in a stand 13. In the stand there is a motor arranged to drive the axis 12 with a constant number of revolutions per second. In addition there is an angle transducer and the slip rings required for signal transmittance through a cable 14 to the other units.

10 The optical arrangements in the sensor head 9 can be seen in in figure 3, where 15 designates a focusing means in the form of a lens. In its focal plane a number of detector elements are arranged into an array 16 with its axis 17 perpendicular to the horizontal principal axis 18 of the lens. On the other
15 side of the lens 15 four plain rectangular mirrors 19 are arranged, whose symmetry axes 20, which are parallel to the short sides of the mirrors, intersect the principal axis 18 of the lens and are parallel to the axis 17 of the detector array 16. The mirrors are parallel relative to each other and the
20 mirror plane forms an angle of 45° to the plane defined by the axes 17, 18. The mirrors 19 are so displaced relatively to each other along the symmetry axis 20, and are of such a size that partly the effective total aperture of the sensor unit is principally the same as the area of the lens, and partly, all
25 the mirrors contribute principally equally to said apertures. As the optical axis 21 of the sensor head, is here defined the axis which meets the axes 18, 20 at right angles by the mirror which is the closest to the lens. It is understood that an object being on the optical axis 21 at a long distance will
30 be reproduced as a dot at the center of the detector array 16.

In figure 4 the focusing means, i.e. the lens 15 and the detector array 16, is drawn with realistic size relations. The detector array has the length l and the lens the focal length f . In the figure has been drawn the rays traced from three different

small objects being at a long distance and so that they are reproduced in the extreme positions and the center, respectively, of the detector array.

It is understood that the field of view α_e of the sensor unit 1
5 in the shown plane is

$$\alpha_e = \frac{1}{f}$$

In this example $\alpha_e = 0.16$ radian or 160 milliradians.

In figure 5 the appearance of the detector array is shown more
in detail. In this example there are 64 similar separate detector
10 elements of the size $a \times b$. In this example $a = 0.2$ mm and
 $b = 0.5$ mm. The length of the detector array is thus
 64×0.5 mm = 32 mm. As a consequence the focal length of the
lens is 200 mm. Each detector element covers a solid angle
of 2.5 mrad \times 1 mrad.

15 From what has been said with respect to figures 2 to 5 it is
evident that the sensor unit can measure simultaneously the
incident-ray intensity in 64 directions 2.5 mrad from each
other within a sector of 160 mrad in the vertical plane, whereby
the resolution is 2.5 mrad in elevation. By rotating the sensor
20 head about the vertical axis 12 in figure 2, measuring can be
effected for azimuth angles throughout the whole revolution with
an angular resolution of 1.0 mrad. Between different revolutions
the elevation of the sensor head is altered with the aid of
the elevation servo 11. A complete scanning can e.g. comprise
25 three revolutions, i.e. a scanning of a range of elevation
of 540 mrad or about 31° . Such a scanning cycle is shown in
figur 6.

A block diagram of the sensor unit is shown in figure 7. Here,
the sensor head is designated by 9, whereas an azimuth motor
30 is designated by 22, an elevation servo by 11, an azimuth angle

transducer by 23, the mirrors by 19, the lens by 15, the detector array by 16, amplifier by 24, a multiplexer by 25 and an A/D-converter by 26. The sensor unit emits output signals 27, 28.

5 The signal 27, then, is a digital signal in series form which in a certain sequence and with a certain scale factor designates the incident-ray intensity measured via the respective detector elements. The signal 28 shows the azimuth direction of the optical axis of the sensor head. The elevation servo 11 is controlled by a signal 29. During a complete scanning cycle
10 of three revolutions the signals 27, 28 and 29 describe the measured radiation intensity as a function of direction in the whole scanned solid angle range, which, as discussed above, in this case covers 540 mrad in elevation and the whole revolution in azimuth.

15 The measuring values produced by the sensor unit to the evaluation unit during a scanning cycle, can mathematically be said to describe a matrix, here designated by A, whose elements a_{ij} designate the measured incident radiation intensity in the direction

20 azimuth = $i \times 0.5$ milliradians
elevation = $j \times 2.5$ milliradians

relative to a chosen reference direction. Below, said matrix will be referred to in connection with an exemplification of the filter functioning.

25 The signal from each separate detector element is read with a spacing in azimuth which is similar to half of the angle width of the detector element, i.e. 0.5 mrad. Totally, a large number of measured values will thus be emitted from detector elements in the form of digital signals to the evaluation unit, where
30 they are stored in a memory, and can be visualized on e.g. a cathode-ray tube in such a way that the picture shows a plane picture of the scene which is covered by the scanned range. In

the picture the luminous intensity in a certain point is a measure of the measured incident IR-radiation intensity in the measuring direction corresponding to the direction of the point.

The evaluation unit 2 is drawn in figure 8 in the form of a block diagram. In it a memory 30 is included, which in this connection is called image memory, a filter 31, a threshold calculator 32, a comparing means 33 and a target memory 34. Via the sensor unit the digital signals from the detector elements are available. In the image memory 30, different combinations of digital signals from the detector elements are stored temporarily, according to a certain sequence, thus representing different parts of the scanned angular range, in such a way, that during a scanning cycle, the signals from all the parts of the scanning range can be processed by the filter 31, which calculates, in a manner, in itself known, the difference between the signal intensity in a chosen direction and the signal intensity in the area surrounding it, area by area of the scanned range.

To determine whether a significant object has been measured or not, a decision function is now used, comprising the threshold calculator 32 and the comparing means 33, which comparing means also has a direct connection with the filter 31.

The function will be shown by a couple of application examples.

In figure 9 are shown vertically from above the mirrors 1, the lens 15, the detector element 16, an object 36, the optical axes of the optical entrances 37-40 and rays from the objects to the optical entrances 41-44. In the figure a scanner is shown in the scanning position $\beta = 0$, i.e. azimuth position 0. The scanning is effected by means of rotation in clockwise direction, i.e. according to the arrow 45. The diameter of the lens is D_{opt} , and the distance between the mirrors d_{12} , d_{23} , d_{34} . The angular distance of the object from the respective optical axis is β_1 , β_2 , β_3 and β_4 and the distance to the object

is R . The extension of the object is D_{obj} .

As an example of measured test results, some diagrams are given below which show the function of the device.

The device has in this example the following dimensions:

- 5 D_{opt} = 0.20 m
 d_{12} = 0.25 m
 d_{23} = 0.50 m
 d_{34} = 0.25 m
 β_1 = 2.00 mrad

- 10 If R is varied from 90 m to 10 km a number of diagrams will be obtained, where the vertical axis in all the cases is related to the signal amplitude.

- 15 As is evident from the choice of d_{12} , d_{23} and d_{34} , the mirrors in this example are arranged in two pairs with regard to the distance. The distance within each pair is 0.25 m. The distance between the pairs is 0.50 m, measured as the distance between the middle two of the four. The aim is to prove the effect of the mirrors being positioned in this particular way.

- 20 When choosing the parameter values, as well as the examples of embodiments of the scanner otherwise, the aim was not to describe an optimal solution but merely to give one solution to illustrate the invention.

- 25 The following examples, figure 10-14, relate to objects which, seen from the device, i.e. the optical entrances of the sensor unit, show a similar solid angle extension and similar radiation intensity, i.e. birds at a comparatively shorter distance and aircraft at a longer distance.

In figure 10 is shown, to begin with, for a 90-m distance, the four optical signals 1-4 which reach the detector via the four

mirrors. The numbering of the signals in figure 10 corresponds to the numbering of the mirrors in figure 9. It is to be observed that the output signal of the detector is equal to the sum of those four optical signals. The output signal of the detector is shown in figure 11 a. In figure 11 b the detector signal is shown in the case of one single optical entrance. Figure 11 relates to the distance 90 m, as does figure 10.

The functioning of the filter 31 will be described with reference to figure 15. The figure shows a section of the matrix A where each element in the matrix is represented by a square check. In the check pattern two areas have been indicated, designated core and frame, respectively. The core comprises three matrix elements, the element a_{ij} being in the middle. The frame comprises the matrix elements which adjoin the core and surround it. The filter function is to calculate the difference between the highest element value in the core and the highest element value in the frame. The calculation is done for every possible position (i, j) in the matrix A. The result is a new matrix B with the elements b_{ij} , which is the output signal of the filter.

The function of the filter 31 is illustrated in figure 16 a and 16 b. Here, the numerical values of the elements in the matrix A have been written. In figure 16 a the highest value in the core is 3 and the highest value in the frame is 3, and so the output signal of the filter is zero. In figure 16 b the highest value in the core is 3 and in the frame 1 and the output signal is then 2. That shows that the filter tends to enhance, i.e. give a big output signal for objects which in the matrix A have an extension which is smaller than or similar to the size of the filter core, whereas larger objects are suppressed, i.e. give a small output signal from the filter.

It could be pointed out, that for the preferred function it would be enough to use a filter which weighs together only

the signals from the plane which contains the object and the optical entrances. In the shown example the filter would be illustrated by row No. i.

In figure 15 the size of the filter core has been given, in
5 azimuth 1.5 mrad and in elevation 2.5 mrad, which values follow from earlier given sampling intervals 0.5 mrad and 2.5 mrad in the respective directions. It can be pointed out here, that an aircraft at a distance of 10 km, seen from the scanner, sub-
tends an angle of generally less than 1.0 mrad, and therefore
10 the aircraft is well within the filter core and will therefore be enhanced by the filter.

It is evident from figure 11 that for the distance 90 m, the amplitude of the detector signal will be considerably smaller with four entrances than with one single entrance. The radiation
15 energy, received by the detector, is the same in both cases, but in the case of four entrances the energy is received within a larger angular range, i.e. at a certain scanning rate, during a prolonged time and therefore at a lower level of power. The output signal of the detector or, more exactly, the output
20 voltage in volts, is in every moment proportional to the incident power in watts. The received energy is represented in figure 11 by the area below the respective curves.

It can also be said, that figure 11 illustrates a situation where the use of four parallel and laterally separated optical
25 entrances results in the suppression of the signal from an object at such a distance from the scanner that the rays from the object reach the entrances of the scanner divergently. By divergent rays it is thereby understood rays with a relative difference of angle which is the same or larger than not too
30 small a fraction of the angular resolution, which in this case is 1 mrad.

In figure 12 are shown, for the distance 500 m, partly the detector signal 1, partly the output signal 2. Fig 12 a refers

to the case of four entrances and figure 12 b refers to one
singel entrance. Fig 2 illustrates the function of the combina-
tion of the four optical entrances on the one hand, and of
the filter on the other hand. From the figure it is evident
5 that the filter reduces the signal level considerably more
in the case of four entrances than in the case of one single
entrance. The reason is that the four laterally separated ent-
rances give a widening of the signal pulse and that the filter
is so arranged as to give a lower output signal when the filter
10 input signal is wider.

In figure 13 are shown, for the distance 130 m, the signals cor-
responding to those in figure 12. Here, two signal pulses
are obtained, in the case of four optical entrances, one for each
pair of mirrors. Figure 13 illustrates the function of arranging
15 the mirrors, with respect to distance, in two pairs, in the
way described above. By arranging the mirrors in this way at
this distance two wide pulses are obtained which the filter
tends to suppress.

In figure 14 are shown, for the distance 10 km, the correspon-
20 ding signals, as in figure 12. From figure 14 it is evident
that the output signal from the filter is almost as big with
four entrances as with a single one. The reason is that the
distance is so great relative to the length within which the
mirrors are positioned, that the rays from the objects reach
25 the scanner parallel, principally. Targets can thus be detected
at long distances as effectively with four laterally separated
entrances as with one single entrance.

It should be emphasized that the described embodiment of a
device according to the invention is an example. As is evident
30 from the accompanying claims and the description above, there
are numerous variants of devices according to the invention.
For instance, the optical entrances of the sensor unit or units
can be positioned vertically in a row.

Even if digital technique is advantageous, it is also conceivable that the signals need not be sampled, nor need they have a digital form. The filter can be designed in different ways. It can e.g. be an analogue filter and function by time instead of
5 by angle.

The transfer function of the filter can be other than that described in the example of embodiment, so long as it is arranged to relatively enhance signals from the objects or parts of objects which, when observed from the position of
10 the sensor and in the spectral range of the sensor, show an angular extension which is less than a chosen value, but suppress or, to a smaller degree, enhance signals from objects which show a greater extension than that chosen.

The transfer function of the filter need not be fixed, but can
15 be variable for adjustment, e.g. according to the actual conditions in relation to the objects.

The spectral range can be other than the IR-range, e.g. the UV-range, the visible range or the mm-wave range.

THE CLAIMS DEFINING THE INVENTION ARE AS FOLLOWS:

1. A device for the selective detection of objects, such as aircraft, missiles, helicopters and alike, by means of outgoing rays from the objects, comprising
5 at least one sensor unit, whereby the sensor unit comprises at least one focusing means arranged to focus said rays to at least one corresponding focal plane, whereby the sensor unit is equipped with at least one radiation sensitive detector element which is positioned in the focal plane, which detector element is arranged to emit signals corresponding to the incoming radiation,
10 whereby the device includes at least two optical entrances so as to be capable of receiving the rays at two distinct points at a relative distance across a line of sight from the device to the object and is arranged to variably scan an angular field in azimuth and/or elevation, whereby the device further comprises an evaluation unit, arranged to receive said signals, characterised in that the
15 evaluation unit is arranged to select objects which seem to be of similar size with respect to the angle measured from the position of the device, in on the one hand large objects being at a long distance, such as aircraft etc., and on the other and small objects being at a short distance, such as birds etc., by suppressing signals whose amplitude as a function of the scanned azimuth or
20 elevation angle shows a relatively great extension compared with signals that show a relatively small extension.
2. A device according to claim 1, characterised by at least two sensor units having the optical entrances for the outgoing rays from the objects at a relative
25 distance across said sight line.
3. A device according to claim 2, characterised in that each optical entrance comprises one deflection means, preferably a mirror arranged to deflect the incoming rays of the entrance to the corresponding focusing means.
30
4. A device according to any one of claims 1 to 3, characterised in that the or



each sensor unit comprises several detector elements, arranged in one dimension.

5 A device according to any one of claims 1 to 3, characterised in that the or each sensor unit comprises several detector elements arranged in two dimensions.

6 A device according to any one of claims 1 to 5, characterised in that the device for scanning in azimuth in addition to the optical entrances own field of view is arranged movable, preferably rotatable.

7 A device according to any one of claims 1 to 6, characterised in that the device for scanning in elevation is arranged movable, for instance step-by-step.

15 8 A device according to any one of claims 3 to 7, characterised in that the or each sensor unit comprises at least one optical scanning means, arranged to scan variably an angular range in addition to the field of view which is seen by the corresponding detector elements in azimuth and/or elevation.

20 9 A device according to claim 8, characterised in that said scanning means consists of said deflection means, arranged so as to be movable.

10 A device according to any preceding claim, characterised in that at least one sensor unit comprises one single focusing means.

25 11 A device according to claim 10, characterised in that said one sensor unit comprises one single focusing means.

30 12 A device according to any preceding claim, characterised in that the device comprises optical entrances, arranged in groups.



13. A device according to claim 12, characterised in that the groups comprise two optical entrances each.

14. A device according to any preceding claim wherein said rays are IR rays.

5

15. A device for the selective detection of objects substantially as hereinbefore described with reference to the accompanying drawings.

10



15

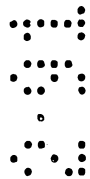

20

Dated this 14th day of February, 1991.



25

DAVIES & COLLISON

30 Patent Attorneys for

SAAB MISSILES AKTIEBOLAG



Fig 1

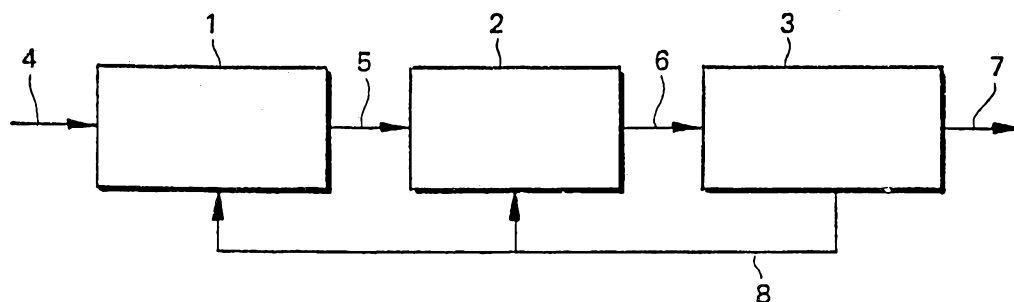

Fig 2

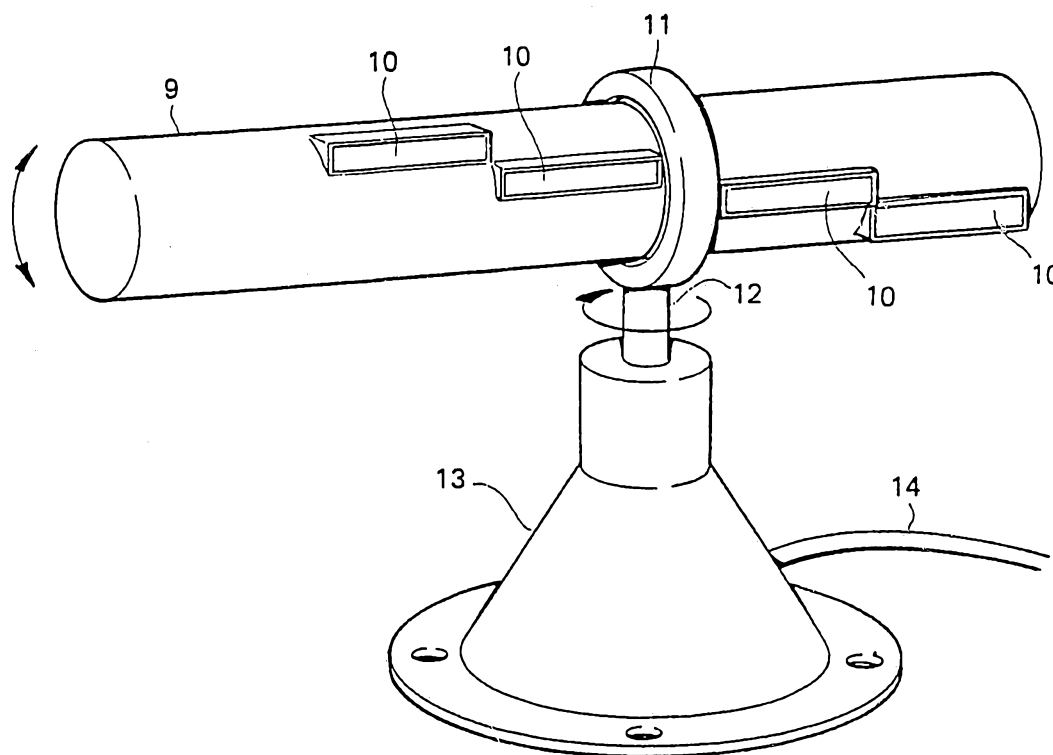

Fig 3

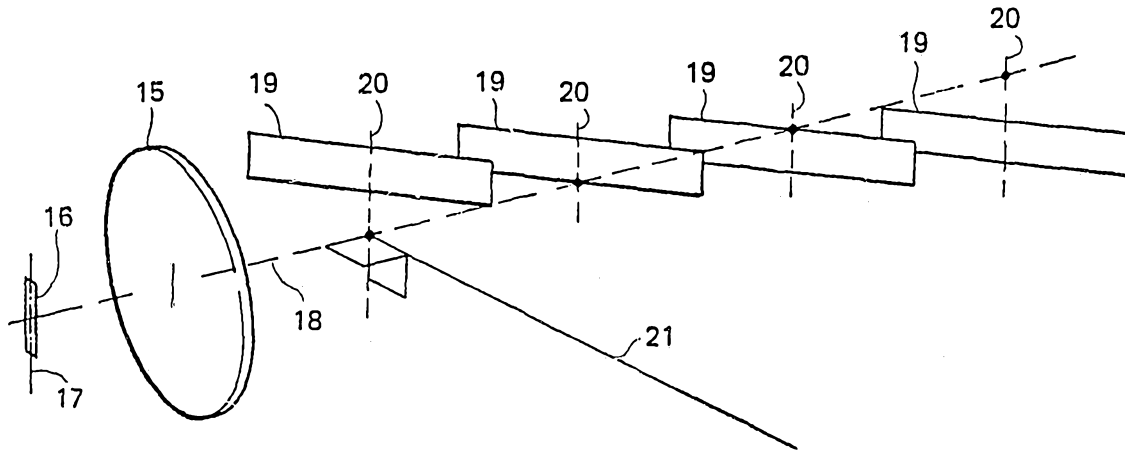

Fig 4

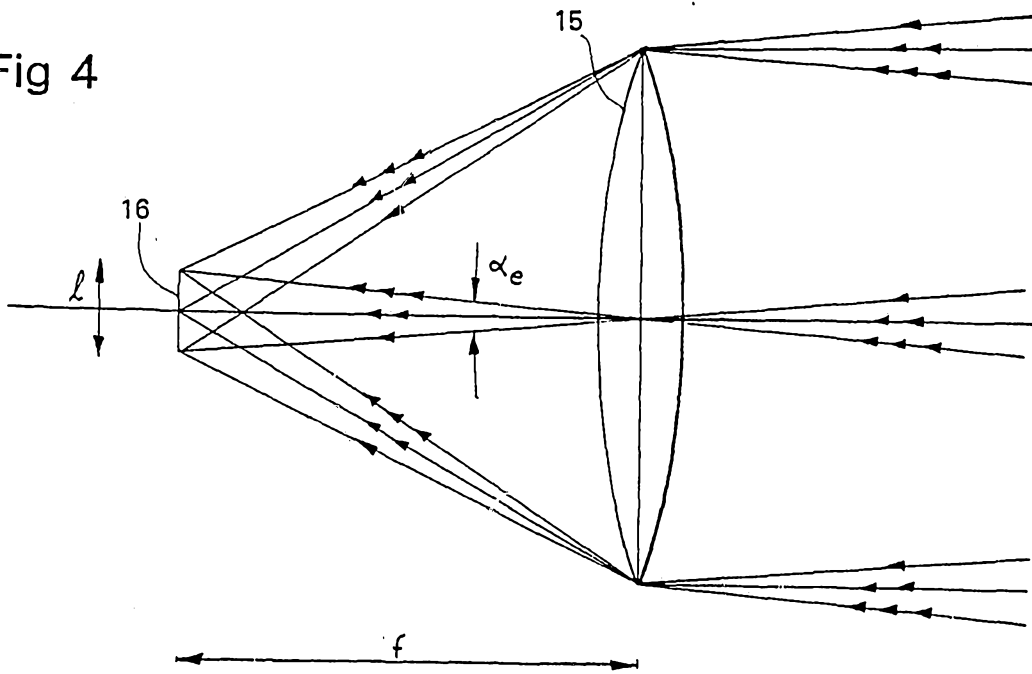

Fig 5

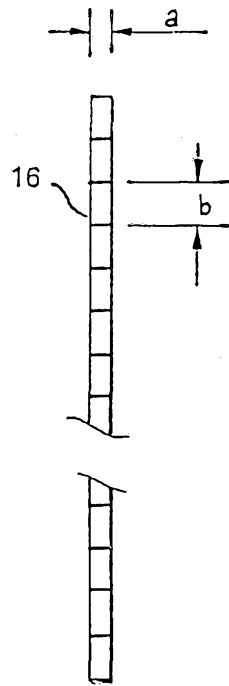

Fig 6.

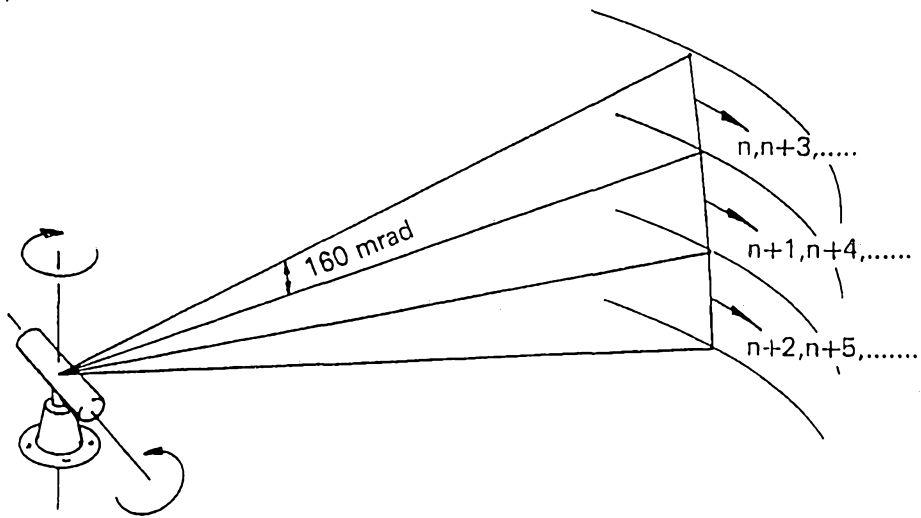

Fig 7

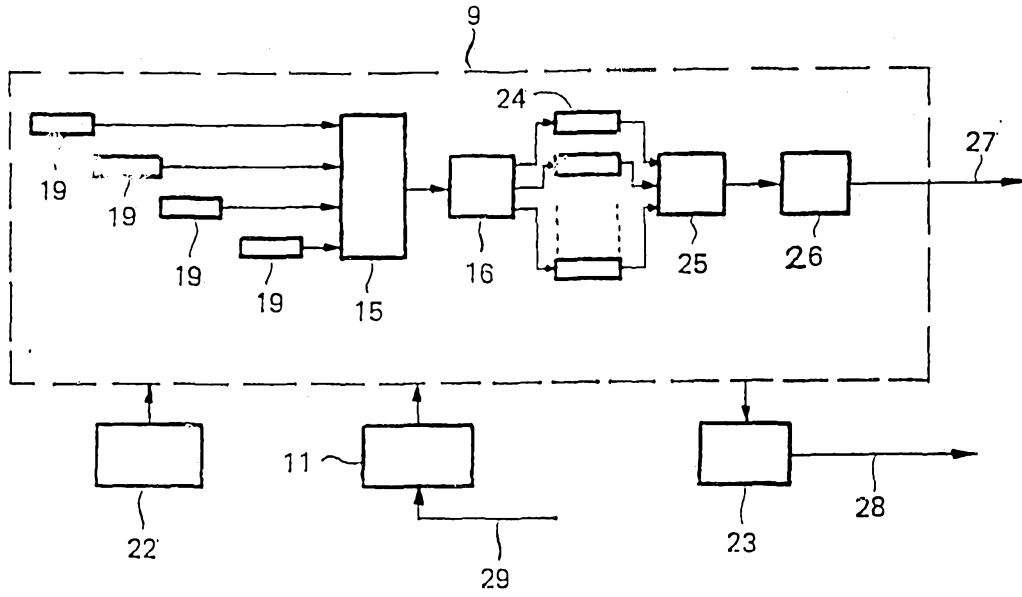

Fig 8

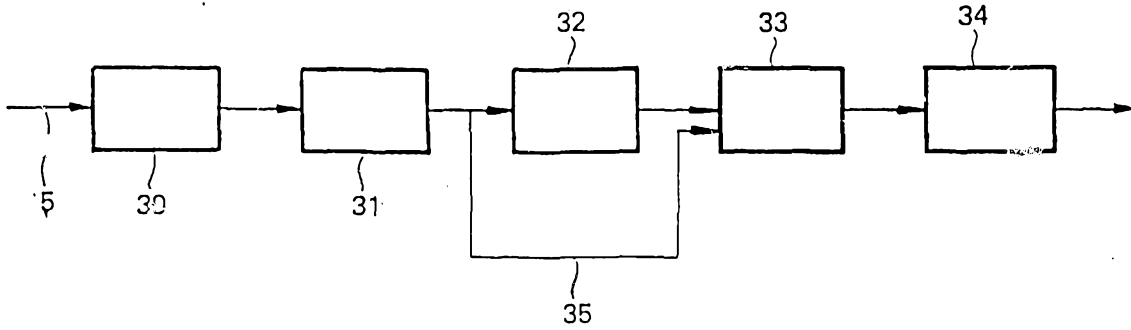

Fig 9

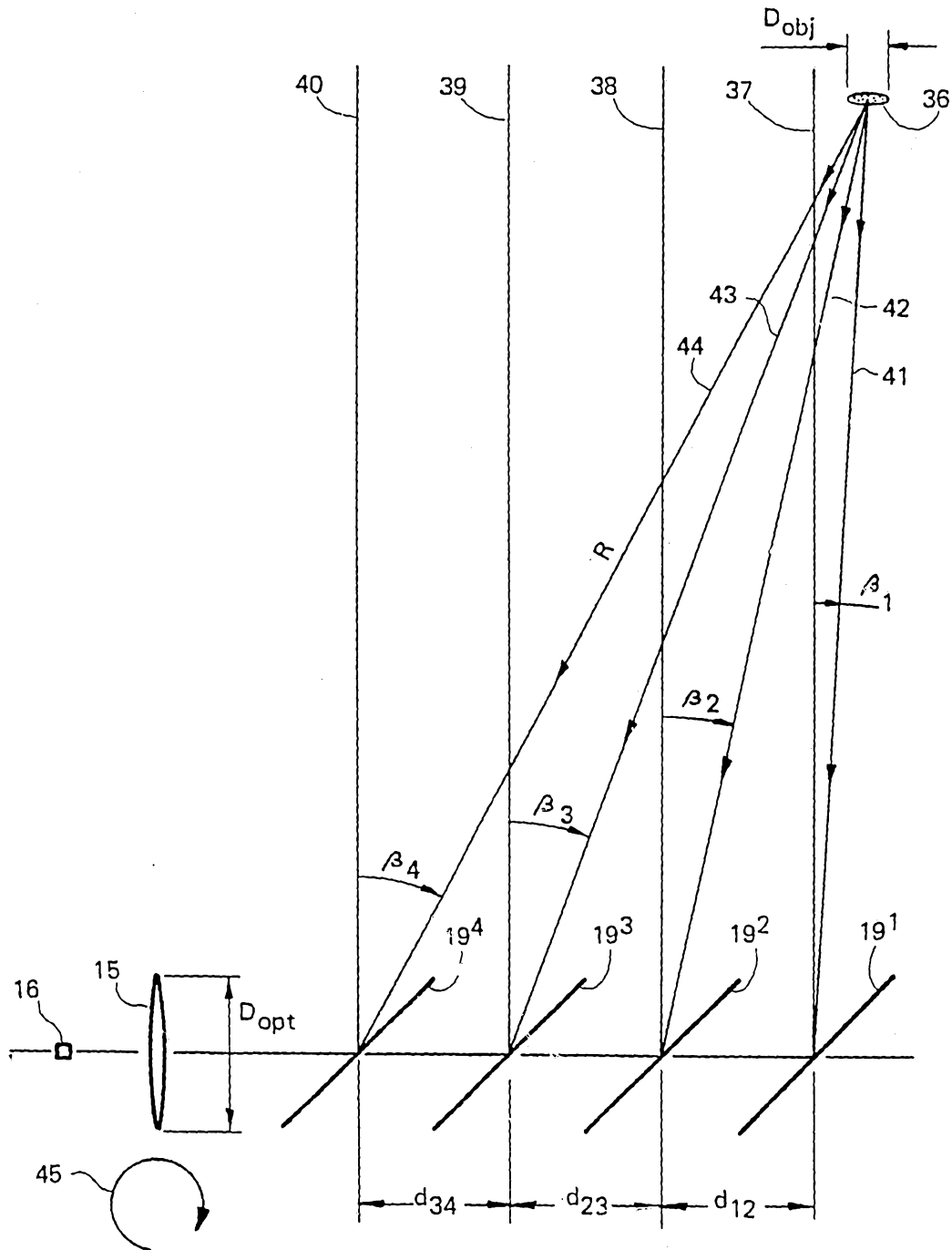

Fig 10

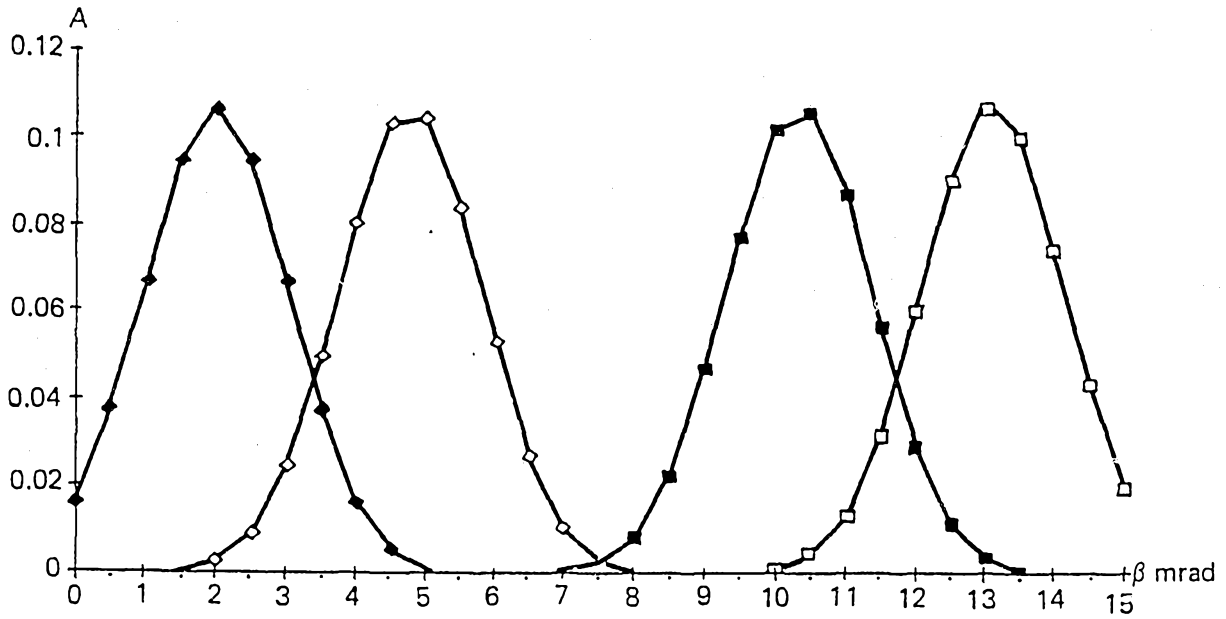

Fig 11

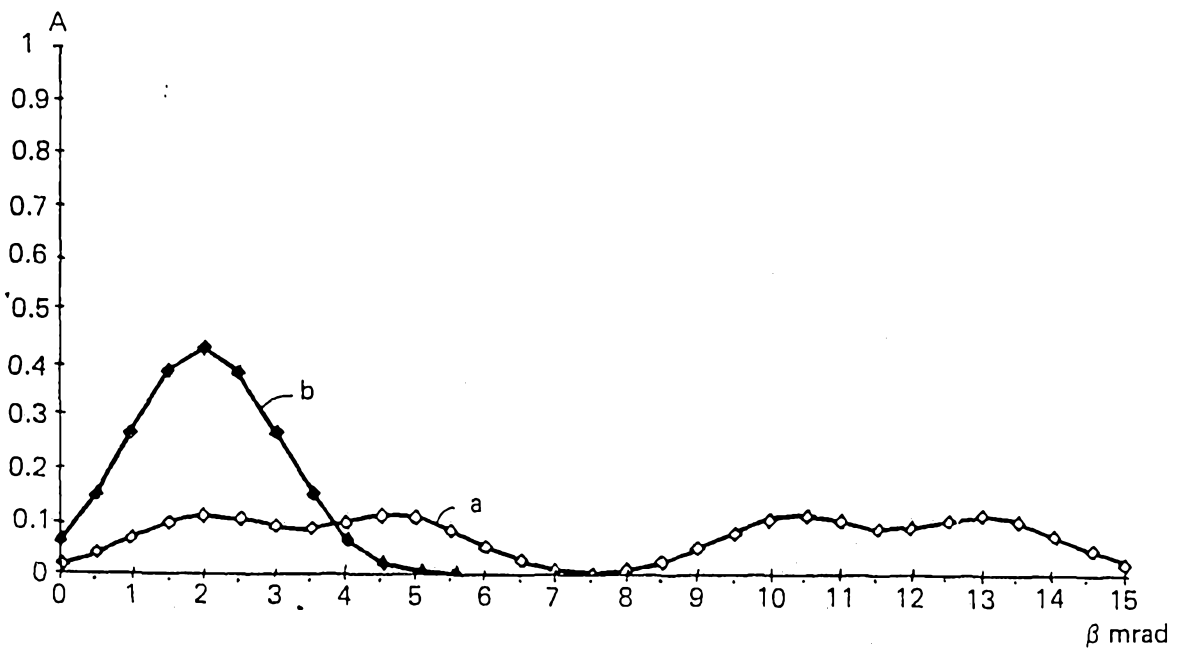

Fig 12

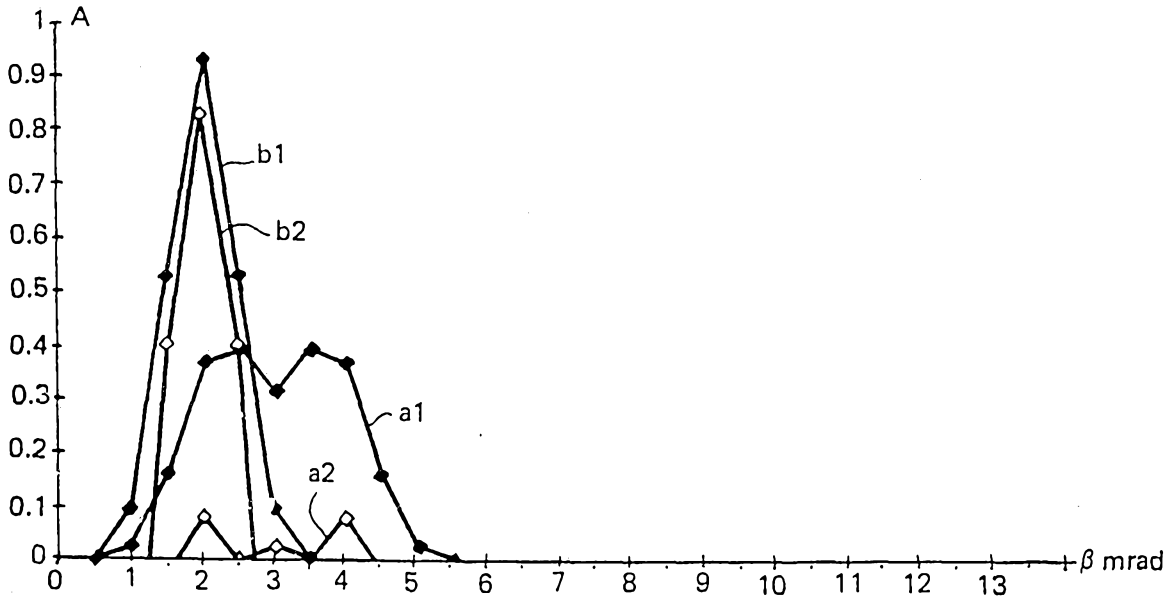

Fig 13

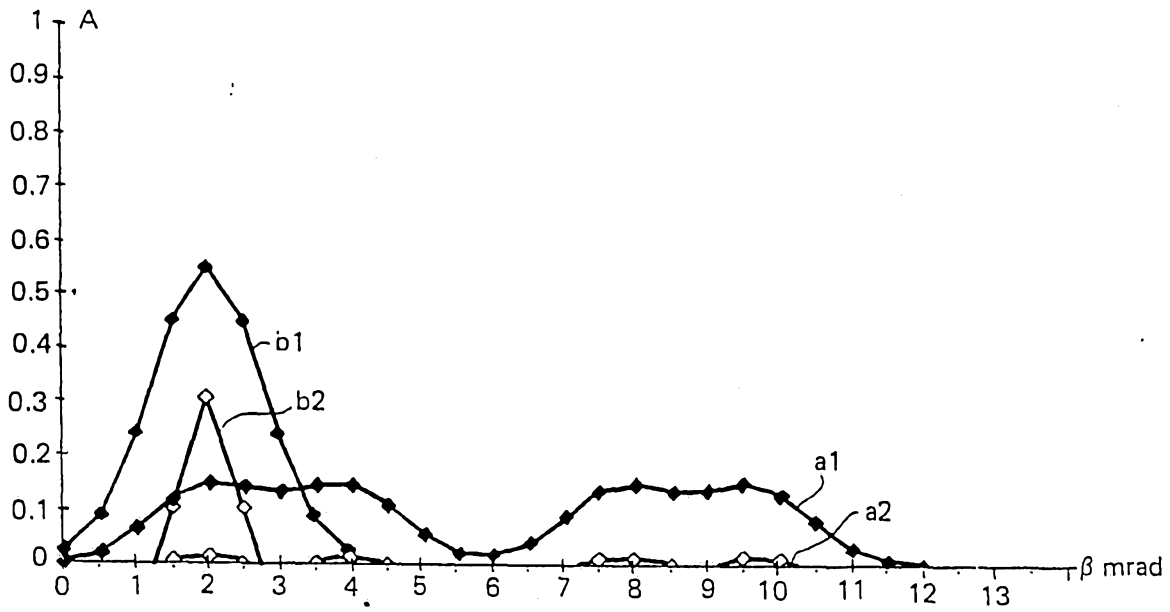

Fig 14a

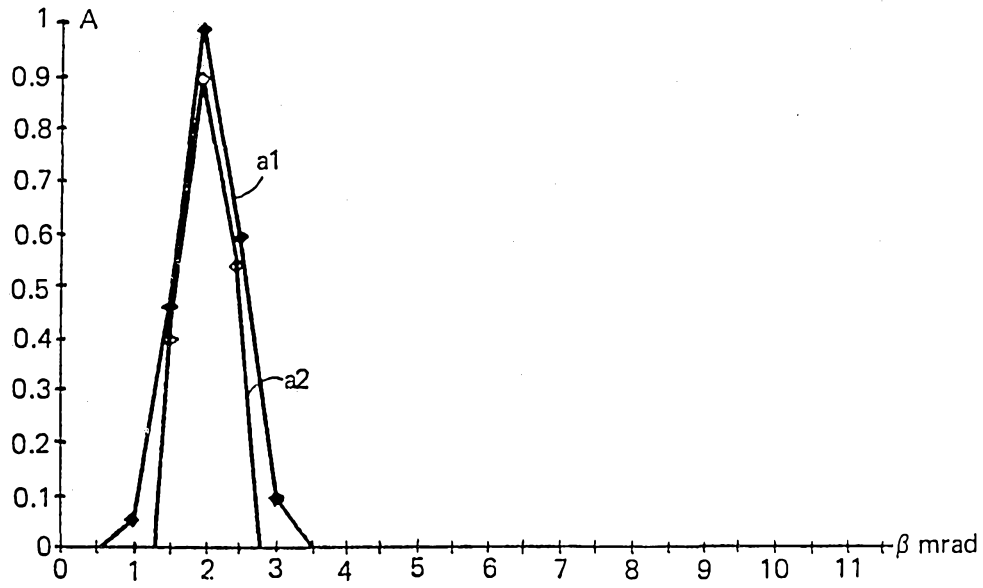

Fig 14b

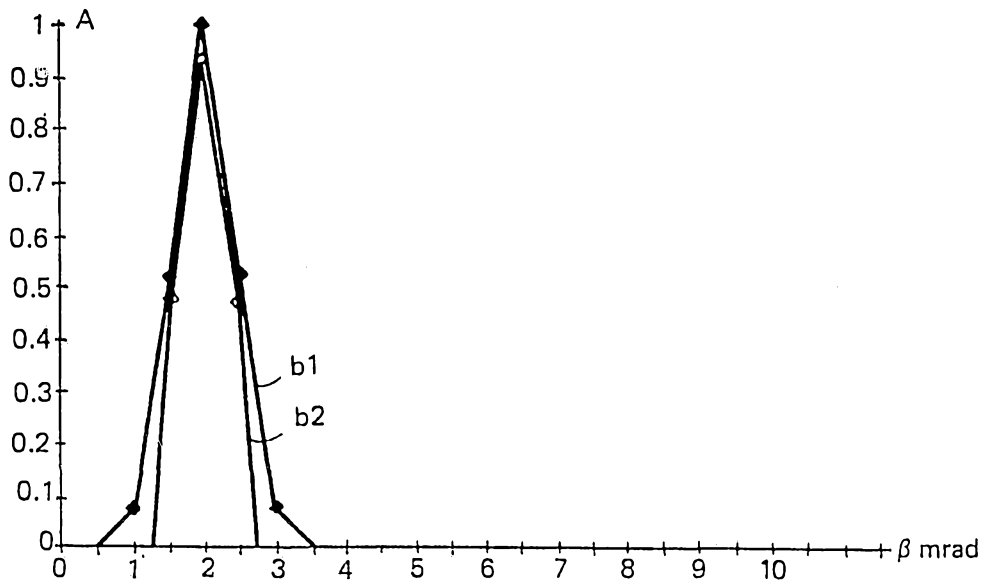

Figure 15

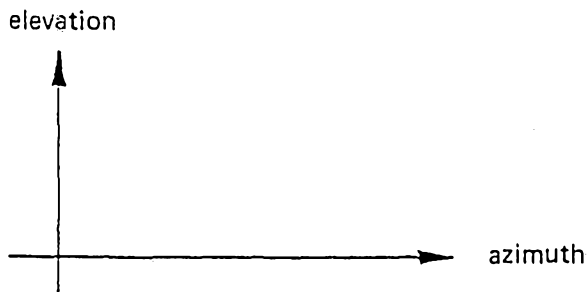
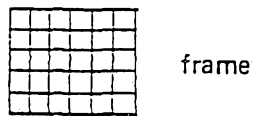
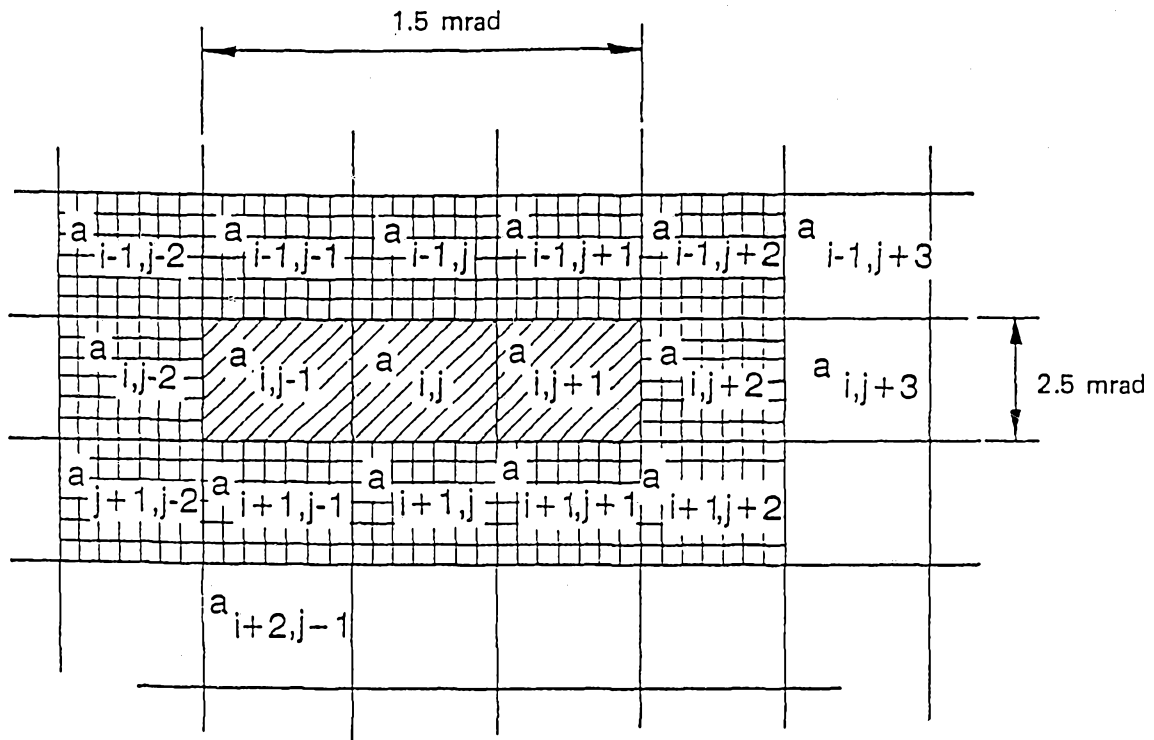

Figure 16a

1	3	1	1	2
0	0	3	3	1
1	1	2	3	0

1 output signal $3 - 3 = 0$

Figure 16b

0	1	0	0	0
1	1	3	2	1
1	1	1	0	0

output signal $3 - 1 = 2$

INTERNATIONAL SEARCH REPORT

International Application No PCT/SE88/00291

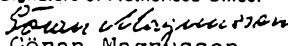
I. CLASSIFICATION OF SUBJECT MATTER (if several classification symbols apply, indicate all) ⁶		
According to International Patent Classification (IPC) or to both National Classification and IPC ⁴		
G 01 S 3/78, G 01 C 3/08		
II. FIELDS SEARCHED		
Minimum Documentation Searched ⁷		
Classification System	Classification Symbols	
IPC US CI	G 01 C 3/08; G 01 S 3/78, 5/16 <u>250:342</u> ; <u>356:1,4</u> , 9-17	
Documentation Searched other than Minimum Documentation to the Extent that such Documents are Included in the Fields Searched ⁸		
SE, NO, DK, FI classes as above		
III. DOCUMENTS CONSIDERED TO BE RELEVANT ⁹		
Category ¹⁰	Citation of Document, ¹¹ with Indication, where appropriate, of the relevant passages ¹²	Relevant to Claim No. ¹³
A	US, A, 2 972 924 (J CLEMENS) 28 February 1961	1-3,8-10
A	US, A, 3 736 057 (D HARVEY) 29 May 1973	
A	US, A, 4 004 852 (E PENTECOST) 25 January 1977	
A	US, A, 4 178 098 (N ASANO ET AL) 11 December 1979	
A	GB, A, 2 068 193 (SEIKO KOKI KABUSHIKI KAISHA) 5 August 1981	
A	US, A, 1 343 393 (SHOFFMAN) 15 June 1920	
<p>¹⁰ Special categories of cited documents:</p> <p>"A" document defining the general state of the art which is not considered to be of particular relevance</p> <p>"E" earlier document but published on or after the international filing date</p> <p>"L" document which may throw doubts on priority claim(s) or which is cited to establish the publication date of another citation or other special reason (as specified)</p> <p>"O" document referring to an oral disclosure, use, exhibition or other means</p> <p>"P" document published prior to the international filing date but later than the priority date claimed</p> <p>"T" later document published after the international filing date or priority date and not in conflict with the application but cited to understand the principle or theory underlying the invention</p> <p>"X" document of particular relevance; the claimed invention cannot be considered novel or cannot be considered to involve an inventive step</p> <p>"Y" document of particular relevance; the claimed invention cannot be considered to involve an inventive step when the document is combined with one or more other such documents, such combination being obvious to a person skilled in the art.</p> <p>"A" document member of the same patent family</p>		
IV. CERTIFICATION		
Date of the Actual Completion of the International Search	Date of Mailing of this International Search Report	
1988-08-26	1988-09-14	
International Searching Authority	Signature of Authorized Officer	
Swedish Patent Office	 Göran Magnusson	