

(No Model.)

E. L. SANDERSON.
DRAWING INSTRUMENT.

No. 523,733.

Patented July 31, 1894.

Fig. 1.

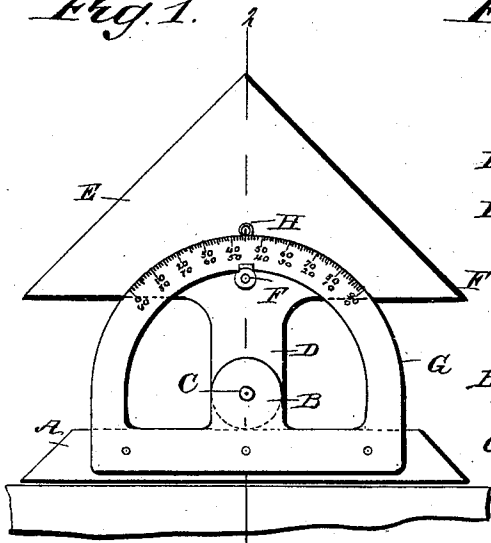

Fig. 2.

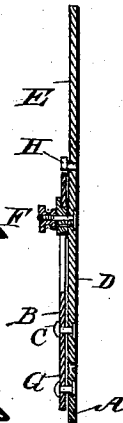

Fig. 3.

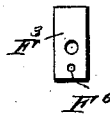

Fig. 4.

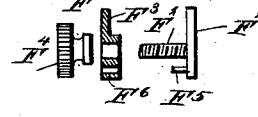

Fig. 5.

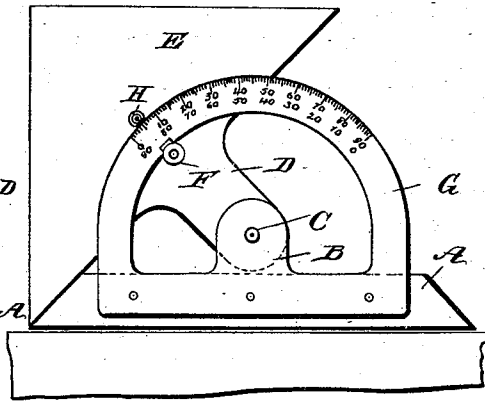

Fig. 6.

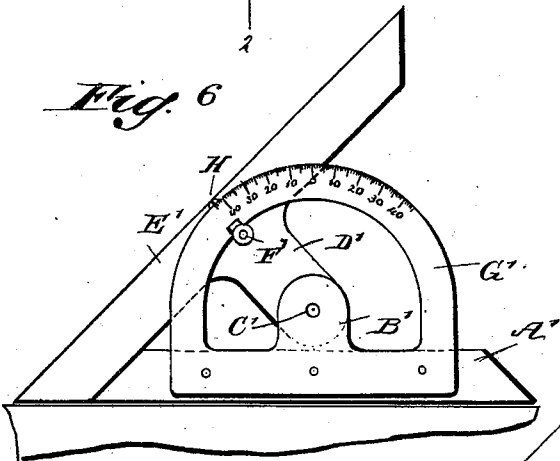

Fig. 8.

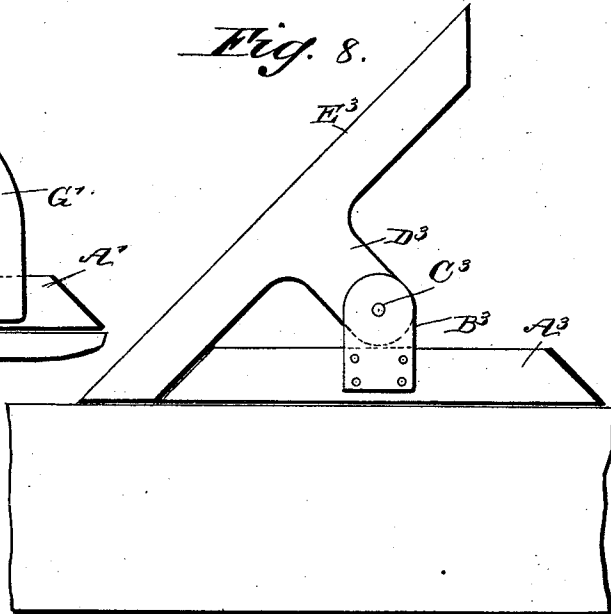
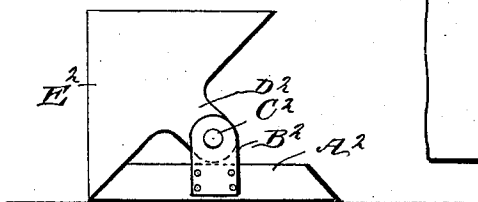

Fig. 7.



WITNESSES:

F. M. Corliss
C. Sedgwick

INVENTOR

E. L. Sanderson

BY *Munn & Co*

ATTORNEYS.

UNITED STATES PATENT OFFICE.

EDMUND L. SANDERSON, OF WALTHAM, MASSACHUSETTS.

DRAWING-INSTRUMENT.

SPECIFICATION forming part of Letters Patent No. 523,733, dated July 31, 1894.

Application filed June 17, 1893. Serial No. 478,001. (No model.)

To all whom it may concern:

Be it known that I, EDMUND L. SANDERSON, of Waltham, in the county of Middlesex and State of Massachusetts, have invented a new and Improved Drawing-Instrument, of which the following is a full, clear, and exact description.

The invention relates to drawing instruments, and its object is to provide a new and improved adjustable triangle, which is simple and durable in construction, and arranged to permit of conveniently drawing lines at any angle to the T-square, and also lines perpendicular to each other.

The invention consists of an adjustable triangle comprising a straight edge and a blade pivoted thereon.

The invention also consists of certain parts and details and combinations of the same, as will be fully described hereinafter and then pointed out in the claims.

Reference is to be had to the accompanying drawings, forming a part of this specification, in which similar letters of reference indicate corresponding parts in all the figures.

Figure 1 is a plan view of the improvement. Fig. 2 is a cross section of the same on the line 2—2 of Fig. 1. Fig. 3 is an enlarged face view of part of the clamping device. Fig. 4 is an enlarged side elevation, with parts in section, of the clamping device, showing the several members disconnected. Fig. 5 is a plan view of the improvement in a different position from that shown in Fig. 1. Fig. 6 is a similar view of a modified form of the improvement. Fig. 7 is a like view of another modified form of the improvement; and Fig. 8 is a similar view of still another modified form of the improvement.

The improved drawing instrument as illustrated in Figs. 1, 2, and 5 with a straight edge A, and with a lug B, in which is arranged a pivot C, connecting the lug B with an arm D, projecting from the base of a right-angle blade E in the form of a triangle as is plainly shown in the figures referred to.

The blade E is adapted to be secured or clamped in place on a protractor G, riveted or otherwise fastened on the straight edge A, and having its center in the center of the pivot C. The clamping device F which is

used for this purpose is provided with a head F', countersunk in the back of the blade E and provided with a threaded shank F² on which is held a clamping plate F³ adapted to engage the protractor G at the inner edge thereof, as is plainly illustrated in Fig. 2. A nut F⁴ screws on the outer end of the threaded shank F² to press the clamping plate F³ firmly in contact with the protractor G. In order to prevent the clamping plate F³ from turning, I provide the head F' with a pin F⁵ adapted to engage an aperture F⁶ in the said clamping plate F³. On the blade E is secured a pointer H indicating on the graduation of the protractor G.

The ends of the straight edge A are preferably beveled, as illustrated in the drawings, and the lug B preferably forms part of the base of the protractor G, as shown in Figs. 1, 5 and 6, so that the blade E is arranged in the same plane as the straight edge A. Now it will be seen that when the nut F⁴ of the clamping device F is loosened, the blade E can be moved in any desired position, so as to bring its outer edge either in a parallel position relative to the straight edge A, as shown in Fig. 1, or in a right-angular position to the said straight edge, as illustrated in Fig. 5. When the blade E is in the position shown in Fig. 5, then the operator can draw vertical lines on one edge of the blade and horizontal lines on the upper edge of the said blade, and when the latter is in the position shown in Fig. 1, the angular lines drawn along the edges of the blade slant at an angle of forty-five degrees to the straight edge A.

It is understood that the angle of the edges of the blade E can be readily varied as desired, by swinging the blade on its pivot C, and then fastening it in place on the protractor by the clamping device F, the pointer H indicating the degree of the desired angle.

As illustrated in Fig. 6, the blade E' is made in the shape of a straight edge having beveled ends and is to be adapted to be clamped to the protractor G' by a clamping device F' similar in construction to the clamping device above mentioned and shown in Figs. 1 to 5. In this case angular lines can only be drawn on one edge of the blade E. Otherwise the construction is the same; that is, the straight

edge A' carries the protractor G' having a lug B' carrying the pivot C', for connection with the arm D' of the blade E'.

5 As shown in Fig. 7, the protractor is omitted and on the straight edge A² is secured a lug B² connected by a pivot C² with an arm D² of the triangular blade E².

10 As shown in Fig. 8, the protractor is omitted and in place of the triangular blade E² is used the blade E³ similar to the blade E', as above described. The straight edge A³ is provided with a lug B³ connected by a pivot C³ with the arm D³ carrying the said blade E³.

15 Having thus fully described my invention, I claim as new and desire to secure by Letters Patent—

1. In a drawing instrument, the combination with a straight edge having beveled ends, of a blade pivoted to said straight edge and
20 having an edge adapted to engage the beveled end of the straight edge and form an angle therewith, substantially as shown and described.

2. In a drawing instrument, the combination with a straight edge having beveled ends, and carrying a lug, of a blade having a projecting arm pivoted to the said lug, the lower

surface of the blade engaging the beveled ends of the straight edge when the blade is in its lowest position to form an angle therewith, substantially as shown and described. 30

3. A drawing instrument, comprising a straight edge having beveled ends, a protractor provided with a lug and rigidly secured to said straight edge, and a blade having a
35 projecting arm pivoted to the said lug and having an edge adapted to engage the beveled end of the straight edge and form an angle therewith, substantially as shown and described.

4. A drawing instrument, comprising a straight edge, a protractor provided with a lug and rigidly secured to said straight edge, a blade having a downwardly projecting arm pivoted to the said lug, and having an edge
45 adapted to engage the end of the straight edge and form an angle therewith, and a fastening device substantially as described for clamping the said blade to the said protractor, as set forth.

EDMUND L. SANDERSON.

Witnesses:

H. P. FIELD,
E. N. REID.