

[72] Inventors **Jacobus Van Laar
Santpoort;
Johannes H. W. Ouwerkerk, IJmuiden,
both of Netherlands**

[21] Appl. No. **867,301**

[22] Filed **Oct. 17, 1969**

[45] Patented **Dec. 14, 1971**

[73] Assignee **Didier-Werke A. G.
Wiesbaden, Germany**

[32] Priority **Oct. 19, 1968
Germany**

[31] **P 18 03 985.5**

[56] **References Cited**
UNITED STATES PATENTS

1,849,657	3/1932	Boynton	263/19
2,514,768	7/1950	Kennedy	431/187 X
2,582,577	1/1952	Fink et al.	431/346 X

Primary Examiner—Edward G. Favors
Attorney—Wenderoth, Lind and Ponack

[54] **HEAT REGENERATOR, PARTICULARLY HOT
BLAST STOVES FOR A BLAST FURNACE**
6 Claims, 2 Drawing Figs.

[52] U.S. Cl. **263/19**

[51] Int. Cl. **F23m 9/00**

[50] Field of Search. **263/19;**
431/187, 188, 346; 239/423, 424

ABSTRACT: A hot blast stove or heat generator for blast furnaces with structure for improving the mixture and combustion of the gas and air fuel components within the combustion chamber, wherein the improved structure includes coaxially disposed but nonintercommunicating center and annularly encircling conduits for supplying respectively the gaseous fuel and air components with a pressure and flow equalizing rod lattice in one or both of the respective conduits. A preferred form utilizes two axially spaced lattices in the gas conduit and one in the air conduit, each of which is adjustable from outside of the furnace to help vary and better equalize the respective flows over the respective cross sections of the conduits.

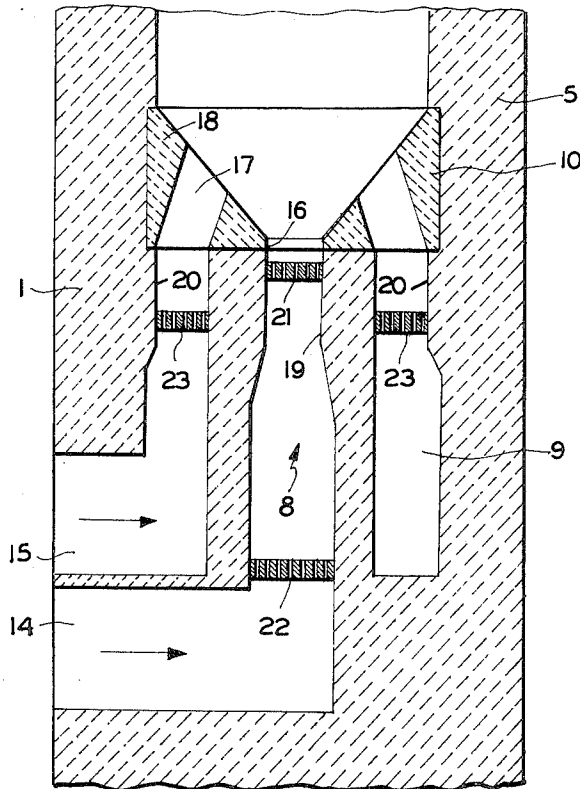

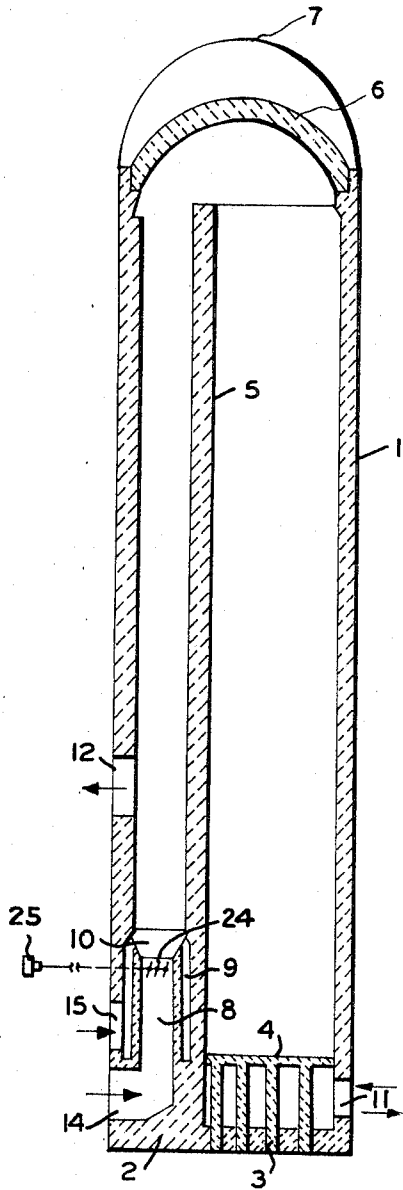

FIG. 1

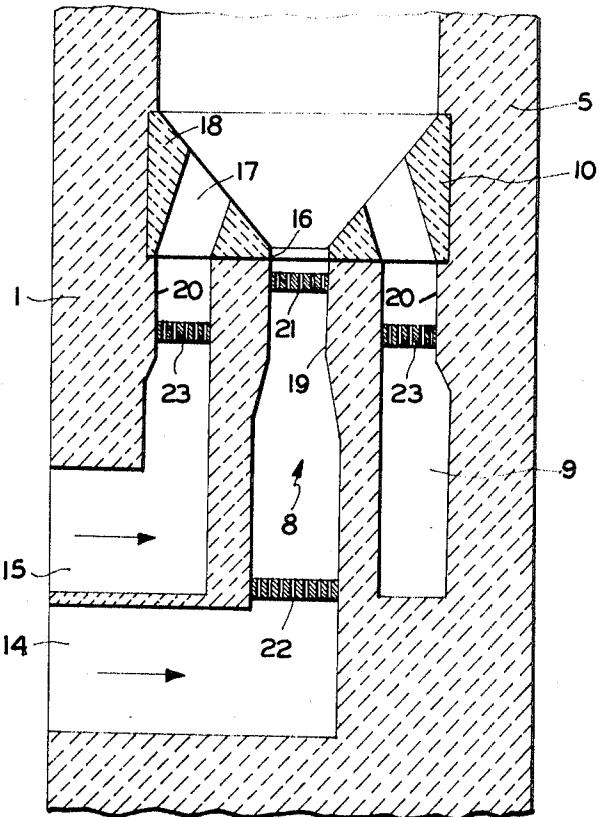

FIG. 2

INVENTORS
JACOBUS VAN LAAR
JOHANNES H.W. OUWERKERK

BY *Wenderoth, Lind & Ponack*
ATTORNEYS

HEAT REGENERATOR, PARTICULARLY HOT BLAST STOVES FOR A BLAST FURNACE

The invention relates to a heat regenerator particularly a hot blast stove for blast furnaces with a vertical burner installed inside the combustion chamber having one vertical conduit for the supply of gaseous fuel and a second conduit coaxial with the first conduit for the supply of combustion air.

Hot blast stoves for blast furnaces are generally used to increase the efficiency degree of a blast furnace by heating the so-called wind before it blows into the blast furnace. For this purpose the wind is led through the hot blast stove, once the stove has been preheated by the combustion of gas. Hot blast stoves are known having a combustion chamber located inside and outside, which means that the chamber where the combustion takes place can be inside or outside a structure which contains a lattice work which is to be heated by the combustion air. This invention refers to both types of hot blast stoves as well as to other similar heat generators which for instance are common in the ceramic industry. Lately vertical, and mainly ceramic burners have been developed for hot blast stoves, which allow a more complete combustion of the gaseous fuel and at the same time preserve better the walls of the combustion chamber than the common burners. By giving the burner an adequate shape it has been achieved that the mixture of gas and air were improved to such an extent that the combustion became more economical.

Nevertheless it was proven that even by using the most modern burners, up in the combustion chamber there still was to be found unburned gas. Supposedly this occurs because of an incomplete mixture of gas and air. It has also been discovered that this happens essentially due to an uneven distribution of gas and air over the cross sections of the air and gas conduits, which can have a great influence upon the large cross sections to be considered here.

An object of the invention is to improve the distribution of gas and air, by putting into at least the first and/or second conduit an adjustable device which equalizes the pressure over the cross section of the conduit.

It has been previously proposed to narrow the conduits shortly before the exit opening, in order to improve the flow condition. It has been proven that this measure alone does not suffice, particularly when the hot blast stove is operated under different circumstances.

It is more advantageous when the pressure-equalizing devices can be adjusted from outside the hot blast stove. In this manner the air and gas distribution can be adapted to almost any working condition.

Pressure-equalizing devices can be gratings, strainers, louvered flap systems, etc. The best results for the operation of a hot blast stove have been obtained with pressure-equalizing devices in the shape of rod lattices.

It is conceivable to further improve the distribution of gas and air in both conduits by installing several lattices. According to the invention an optimal operation can be achieved with two lattices in the gas conduit and one lattice in the air conduit. A further improvement can be obtained by narrowing the conduits, and by placing a lattice in the narrowed part of each conduit.

Actually such narrowing of the conduits is known. A certain improvement of the combustion could be attained formerly thanks to such narrowings. But only by placing lattices in the narrowed conduit parts can the best results be obtained.

The improved results due to the invention can be obtained when using it on hot blast stoves with interior and exterior combustion chambers.

Further objects of the invention and details of the advantages gained are illustrative hereafter in the drawings which schematically show an example of operation of an installation according to the invention, wherein:

FIG. 1 shows a longitudinal section of a hot blast stove with an interior combustion chamber.

FIG. 2 shows the burner of the hot blast stove of FIG. 1 on a larger scale.

In FIG. 1 the housing 1 of a hot blast stove forms with the bottom 2 on which it stands a bricked unit. The brick housing 1 is surrounded by a steel casing (not shown). A number of pillars 3 projecting out of the bottom 2 support a lattice 4, which in its turn supports the perforated stones piled up on it (not shown) through which alternately hot combustion gas goes down and heated air is led upwards. This so-called lattice work is separated by a wall 5 from the combustion chamber, which in turn is limited outside by a section of the housing 1.

The hot blast stove is closed on the upper part by a brick cupola 6 and a steel cupola 7.

The gaseous fuel and air needed to preserve the hot combustion gases are supplied through a conduit 8 and/or through a ring conduit 9 to burner 10. The burner is schematically shown in FIG. 1.

Above the burner 10 the fuel and air are intimately mixed and the fuel is burnt in the combustion chamber. The hot combustion gases are led over separation wall 5 downwardly. Once the piled up stones in the lattice work are sufficiently heated the supply openings 14 and 15 of the fuel and air conduits 8 and/or 9 are closed.

The air to be heated is then led through an opening 11 in opposite direction through the installation and can escape through opening 12.

FIG. 2 shows a burner and its surroundings in detail and on a larger scale.

The central conduit 8 for the fuel connects with a central hole 16 in the burner 10. This burner is manufactured of ceramic material, as well as the walls of the conduits 8 and 9 and the walls 1 and 5 of the combustion chamber.

In the upper surface 18 of the burner 10, discharge slot-shaped openings 17, are in connection with conduit 9.

With an adequate shape of the burner an almost optimal mixture of the fuel and the air can be obtained under the condition that the fuel and the air are actually equally distributed over the cross section of the hole 16, and/or the openings 17. The latter is obtained when narrowing conduits 8 and 9, and by installing rod lattices. The narrowing in the conduits 8 and 9 are shown at 19 and/or 20 in FIG. 2.

In conduit 8 two rod lattices have been provided, lattice 21 in the narrowed conduit part 19, and a second lattice 22 not far from the lower end of conduit 8. In ring conduit 9 there is only a single ring-shaped rod lattice 23 in the narrowed conduit part 20. Any suitable means for effecting adjustment of the pressure- and flow-equalizing means may be utilized such as schematically depicted louvre traps 24 (FIG. 1) adjustable by any suitable control, such as handle 25.

When operating such a hot blast stove almost no unburned fuel remainders can be measured in the cupola and under the lattice work, which indicates an almost complete combustion.

We claim:

1. In a heat generator, particularly a hot blast stove for blast furnaces having a vertical burner installed inside of a combustion chamber, improved means for providing a more even mixture and complete combustion of gaseous fuel components, said improved means comprising a first vertical conduit for and connectable with a supply of gaseous fuel, a second conduit coaxial with said first conduit for and connectable with a supply of combustion air, pressure- and flow-equalizing means in at least one of said conduits to equalize the pressure and flow more completely over the cross section of said conduit to form an even and more regular mixture of gaseous fuel, and said first and second conduits being separately, noncommunicatively disposed with their respective outlets relatively concentrically spaced from one another so that responsive to the even and more regular flowing of the gaseous fuel components, the intermixing of the fuel components and the subsequent combustion occurs above said burner in the combustion chamber resulting in a more efficient and complete combustion.

2. A heat generator according to claim 1 wherein said pressure-equalizing means include means to enable them to be adjustable from the outside of the hot blast furnace, for instance, the inclusion of movable louvered traps.

3

4

3. A heat generator according to claim 1 wherein said pressure-equalizing means are in the form of rod lattices.

4. A heat generator according to claim 1 wherein said pressure-equalizing means comprises consecutively two relatively spaced lattices in the gas conduit, and further includes a lattice assembly in the air conduit.

5. A heat generator according to claim 1 wherein said con-

duits are respectively narrowed down and a lattice is disposed in the narrowed part of each conduit.

6. A heat generator according to claim 1 wherein operable louver traps are disposed as the pressure-equalizing means and having adjustable devices operably connected therewith for adjusting same from outside the generator.

* * * * *

10

15

20

25

30

35

40

45

50

55

60

65

70

75