

May 15, 1962

W. A. TROTT
LUMINAIRES

3,035,165

Filed July 5, 1957

2 Sheets-Sheet 1

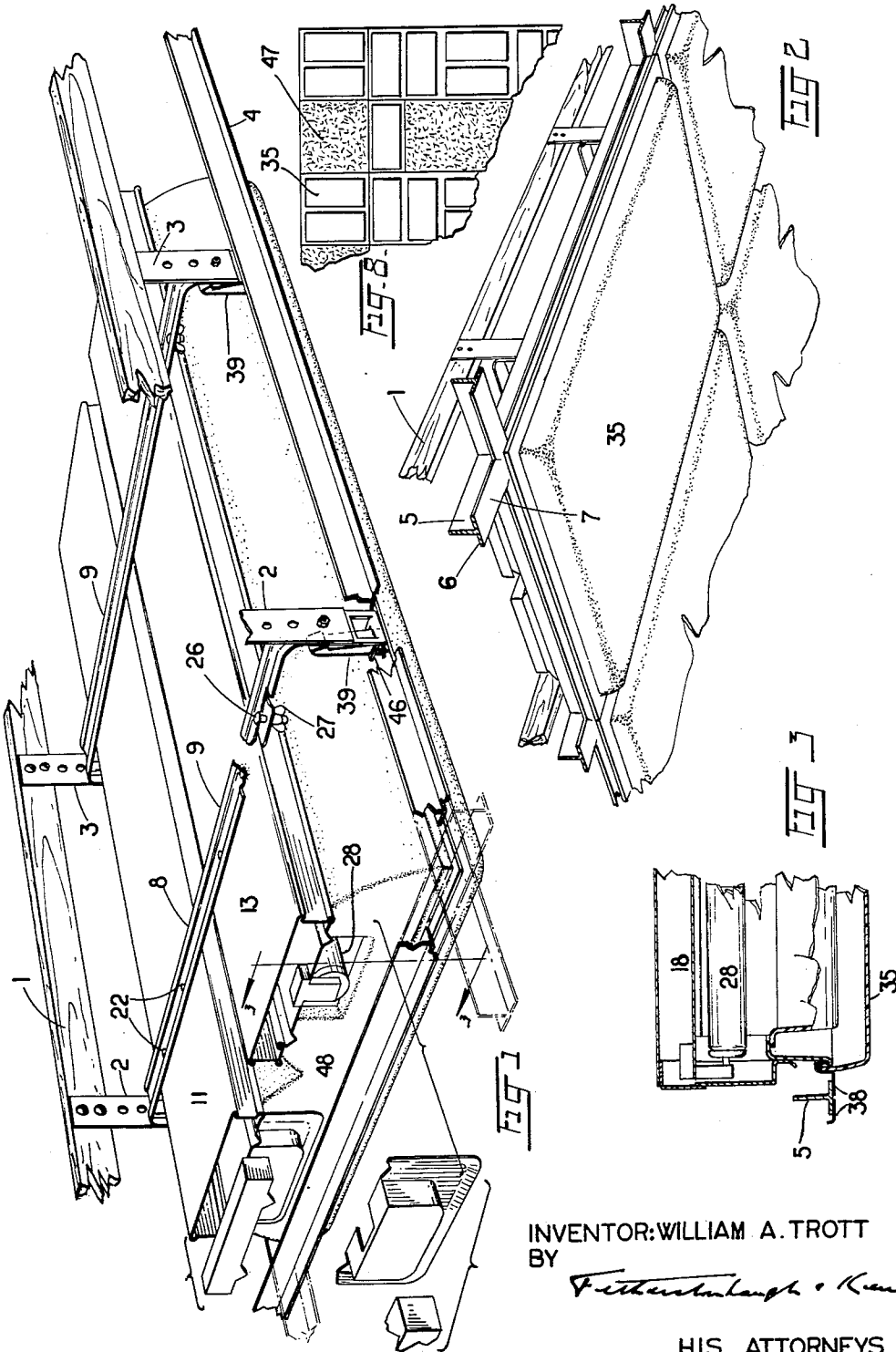

INVENTOR: WILLIAM A. TROTT
BY

Featherstonhaugh & Kears

HIS ATTORNEYS

May 15, 1962

W. A. TROTT

3,035,165

LUMINAIRES

Filed July 5, 1957

2 Sheets-Sheet 2

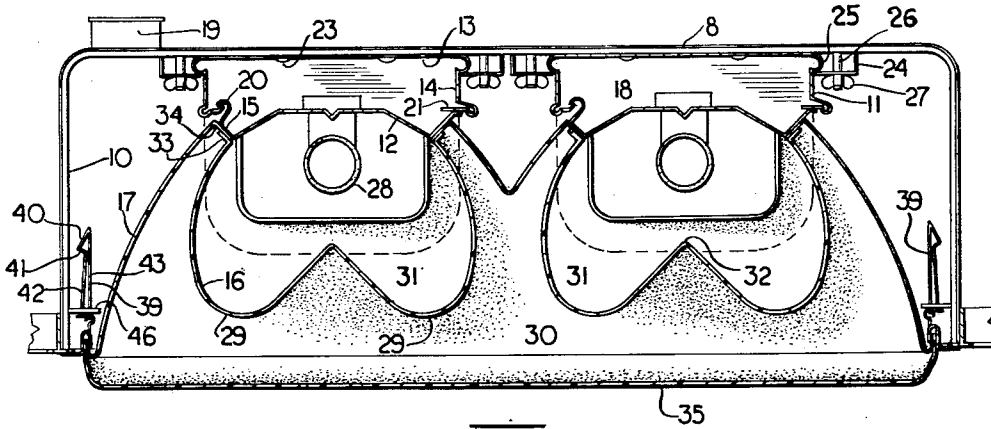

FIG. 4.

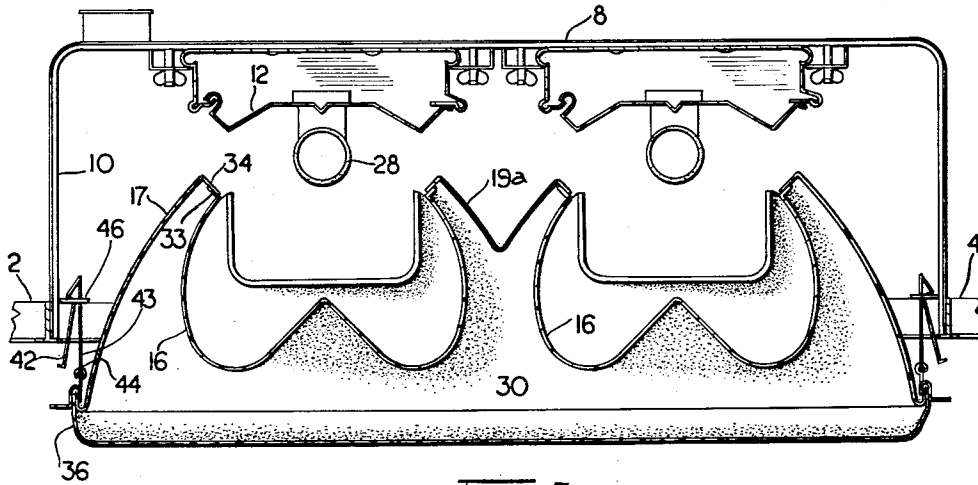

FIG. 5.

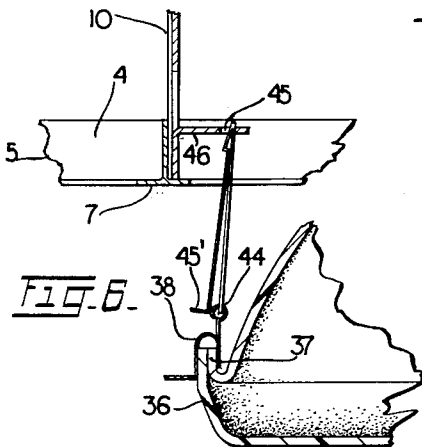

FIG. 6.

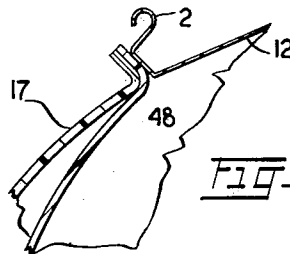

FIG. 7.

INVENTOR: WILLIAM A. TROTT.
BY

Friedenthal & Kees

HIS ATTORNEYS

1

3,035,165

LUMINAIRES

William A. Trott, Winnipeg, Manitoba, Canada

Filed July 5, 1957, Ser. No. 670,234

1 Claim. (Cl. 240—78)

The present invention relates to luminaires, the same being an inventive variation over the subject matter of my copending United States patent application Serial No. 563,804 filed on the 6th day of February 1956. In the present modification however I have provided means to adjust laterally the position of my wiring boxings within associated mounting structure. Additionally I have varied the cross-sectional configuration of my light-passing cells to effect an even more uniform distribution of subdued light particularly when, as will usually be the case, the individual modular unit herewithin described is mounted in series over the whole, or a designated substantial area, of a false wall or ceiling erected to receive the same.

With the foregoing more important objects in view, and such other objects and advantages as will become apparent to those skilled in the art to which this invention relates as this specification proceeds, my invention consists essentially in the arrangement and construction of parts all as hereinafter more particularly described, reference being had to the accompanying drawings in which:

FIGURE 1 is a perspective representation of my present luminaire including associated mounting structure as viewed from above and with certain parts shown in exploded relationship.

FIGURE 2 is a perspective representation of the luminaire of FIGURE 1 viewed from below.

FIGURE 3 is a fragmentary sectional elevation of my wiring boxings, cell, and a portion of the associated mounting structure viewed in parallel with the source of light.

FIGURE 4 is a transverse sectional elevation of my luminaire shown with light diffusion cell in closed or fully functioning position.

FIGURE 5 is a view from the aspect of FIGURE 4 but with the cell shown semi-detached from the associated mounting structure.

FIGURE 6 is a fragmentary view from the aspect of FIGURES 4 and 5 but showing my cell in relation to a connector as in process of being wholly detached from the associated mounting structure.

FIGURE 7 is a fragmentary sectional representation of a modified shielding-panel and reflector-panel junction.

FIGURE 8 is a synoptic fragmentary underside plan representation of a ceiling pattern embodying my luminaire.

In the drawings like characters of reference designate similar parts in the several figures.

It is clearly to be understood at the outset that my luminaire is equally designed for installation as the means for illuminating a wall or a ceiling. In this specification I describe the same as suspended from a ceiling. In the accompanying FIGURE 1 therefore, members 1 represent conventional ceiling rafters, although, if it is desired to avoid breaking up a structural ceiling to reach the same, a network of sub-rafters will readily suffice for the suspension of my luminaire which I will now describe.

Projecting (downwardly in the case of a ceiling, outwardly in the case of a wall) is my mounting structure collectively designated 2. This includes hangers 3 to which a grid collectively designated 4 is connected. This grid will be seen from the accompanying FIGURES 1 and 2 to comprise intersecting inverted T bars 5 having flanges 6, the anterior or lower surfaces 7 of which lie in a common plane.

Also forming part of my mounting structure are the brackets 8 preferably, though obviously not necessarily of inverted U configuration. These span the hangers 3.

2

They comprise the transverse cross-bars 9 and the side-arms 10 thereof, the said cross-bars being recessed with respect to the aforesaid common plane of grid 4.

Connected to my mounting structure 2 are light-reflecting means in the preferred form of a wiring boxing collectively designated 11. This embodies the posterior reflector 12 in the form of an elongated plate, posterior mounting pan 13 and side walls 14. These, together with the elongated flanges 15 at the junction of my shielding and reflector panels 16 and 17 respectively, enclose an elongated rectangular area 18. Alternatively, an external wiring channel 19, may, if preferred be attached to brackets 8.

As will best be observed from the accompanying FIGURE 4, in the construction of my wiring boxings, the wiring boxing 12 is hinged along the edge 20 to the adjacent side wall. The opposite edge will be closed against edge 21 by self tapping screws or the like. The back pan 13 and U-bracket cross-bars 9 are provided with means for adjustably positioning my said boxings between the side arms of the U-brackets. These means comprise spaced, downwardly punched dimples 22 in the said cross bars. They are registrable with similar dimples 23 formed in back pans 13. Dimples 22 are equi-spaced across bars 9. Hence, it will be obvious that should I desire to mount only one wiring boxing assembly centrally with respect to the U-brackets 8, rather than the duplex wiring boxings depicted, the aforesaid dimples provide for automatic position-finding. The remaining portions of my means for positioning the wiring boxings between the U-brackets consists of the right angular brackets 24 the horizontal ends of which clamp against the beads 25 of back plate 13 when the associated bolts 26 (which extend through members 24 and into the cross-bars 9) are tightened via the wing nuts 27.

Light-source 28 which will generally take the form of a fluorescent tube is surrounded by the aforesaid reflector plate 12 upon the posterior side thereof, and by the aforesaid elongated light-transmitting and shielding panel 16. The latter forms the interior (or posterior) surface-portion of light diffusion means comprising a light-passing or light-diffusing cell collectively designated 30 and preferably fabricated wholly of synthetic sheet plastic material. Being of approximately inversely frusto-cordate cross-section, shielding panel 16 also functions to inclose with reflector 12 an elongated light chamber 31 of approximately this shape. Such shape is highly efficient since the elongated end partially bisecting ridge portion 32, being situated in the axial plane of light-source 28 more uniformly diffuses light passing through shielding-panel 16. Obviously however, the lateral portions of this panel may conceivably be made to diverge upwardly instead of converging towards flanges 15 as I have depicted. The significant feature of a shielding panel such as I have described being the anterior lobes 29 thereof, I define this member in the claim appended hereto as bi-lobate rather than frusto-cordate where the former expression appears more adequate.

The edges of shielding panel 16 are outwardly flanged as at 33, and interfacially sealed against the posterior flanges 34 of reflector panels 17. These reflector panels, it will be observed, diverge anteriorly from shielding panels 16. Flanges 34 of cell 30 abut interfacially the flanges 15 of wiring boxing 18 as most clearly depicted in FIGURE 5 where the cell is to be observed semi-detached from its mounting structure.

From FIGURE 5 it will also be clearly apparent that my cell 30 includes both the aforesaid light-diffusion presentation panel 35 and reflector panel 17. The former is marginally flanged as at 36. Such flange overlaps the anterior, reversely angulated flange 37 of reflector panel 17. These flanges, which may be mutually bonded, are

3

also held united by surrounding flange 38 of the cross-sectional process best illustrated in accompanying FIGURE 6. Such flanges, when my cell is in situ, bear interfacially against the surfaces 7 of members 5.

From the foregoing it will be recognized that my cell 30, in the duplex modification thereof best illustrated in the accompanying FIGURES 4 and 5 consists of the pair of shielding panels 16, the chevron strip 19a which connects the same and also functions as a bi-facial partial reflector panel, the main or flanking reflector panels 17, and presentation panel 35. Such cell, together with each pair of inverted U-shaped brackets 8 embracing the same, as well of course as the wiring boxings 11, reside as I have defined it in the accompanying claim, posteriorly recessed with respect to grid 4.

The opacity of panels 17 and chevron strip 19a enabling the same to function as reflectors, is preferably, though not necessarily, achieved by coating the same upon their exterior surfaces. In this way, light can be absorbed before being reflected back, and in this way will pass or "bleed" out to the extreme edges of flanges 38, if these be of translucent plastic, via flanges 37. Thus, as depicted in the accompanying FIGURE 3, when two adjacent flanges 38 are in contact with the anterior surfaces of grid members 5, and a battery of luminaires in operation, no division or network of shadow will be discernable between them.

It should perhaps be specifically explained at this place that a cell 30 designed to enclose only one source of light 28 within a pair of brackets 8 would be entirely similar to the duplex form which I have detailed excepting for the fact that the reflector panels 17 would diverge or flair more widely from their posterior connecting edges with shielding panel 16, so that their anterior flanges would reach out to abut flanges 36 as in the duplex form shown. Chevron strip 19a would of course be eliminated. In all other respects a mono light-source shielding cell would be as I have depicted for the duplex modification.

It will clearly be recognized that my reflector panels 17 are substantially and operatively a continuation of posterior reflector 12 even though, in the principal embodiment of FIGURES 1 through 5, the former are shown stepped back as it were due to the interposition of flanges 15. Accordingly I have depicted in the accompanying FIGURE 7 a very slight modification wherein it will be observed that reflector panels 17 are oppositely or outwardly flanged rather than inwardly flanged as in the principal modification.

In the accompanying FIGURES 5 and 6, I have depicted my means for removably maintaining cell 30 in place. Since however these means are described in principle in a copending United States application, they will only be described herein for the purpose of indicating a slight structural difference, and for the purpose of associating them with the present particular embodiment.

In FIGURE 4, my cell 30 is depicted held fully in situ by connector 39. Such connector takes the form of a hairpin bent spring strip having a substantially lanceolate leading end 40 presenting a yieldable retaining shoulder 41. The arms 42 and 43, when relaxed as in FIGURE 5, diverge. Arm 43 is hingedly connected at the end 44 remote from the leading end 40, to flange 38. The said connector is designed to project through a rectangular aperture 45 in a knock-out 46 formed in each of side arms 130. Arm 42 thereof is provided with a stop-foot 45' designed in the fully closed position of FIGURE 4 to bear against the anterior surface of knock-out 46. It is to be understood that in this position, cell 30 hangs from the connectors 39, the arms 42 and 43 of which bear outwardly against the opposite edges of aperture 45 under sufficient spring pressure to support the said cell.

In FIGURE 5 I have depicted my cell 30 as semi-detached from the associated mounting structure following its having been moved into the position illustrated by ap-

4

plying the fingers of right and left hands against the projecting edges 36 of presentation panel 35 and pulling downwardly. In this position, the shoulder 41 has come to rest against the posterior surface of receptacle 46 in the form of a knock-out. Hence, when the arms 42 and 43 are compressed or squeezed together, the leading end is contracted as illustrated in FIGURE 6, preliminary to complete detachment of my cell, since such leading end may now be moved through aperture 45.

In FIGURE 8 I have illustrated one of many ceiling or wall designs in plan. In this representation, the area of several presentation panels 35 are represented intervened by opaque panels 47. Thus, when modular proportions such as 18 inches wide by 36 inches long are employed as the overall dimensions of each luminaire, many pleasing designs can be achieved.

It should be observed that although I have described the shielding panel 16, reflector panels 17 and presentation panels 35 as sealed together to form a unitary cell, it will be obvious that, without departing from the spirit of this invention, the reflecting panels and shielding panels only may be sealed together and the presentation panel attached separately. Or, the reflector panels and presentation panels may be sealed together but made separate from the shielding panel. It should finally be observed that end walls 48 close the ends of my cell 30.

Having thus described my invention, I express the inventive concept embodied therein as broadly residing in the combination of a mounting structure collectively designated 2 in the form of a grid collectively designated 4, with a wiring boxing including essentially the single or multiple reflectors 12, the exemplified means 22 for adjustably positioning the said boxing or boxings upon a mounting structure, and with a light-diffusing cell collectively designated 30 when in perimetrical contact (as at the location of flanges 15 for instance) with a wiring boxing, together with (an ancillary inventive concept for separate use if desired), the connector means such as collectively designated 39, for maintaining a cell in such perimetrical contact.

Since various modifications may be made in my invention, and many apparently different embodiments of same made within the spirit and scope thereof without departing from such spirit and scope, it is intended that all matters described in the accompanying specification shall be interpreted as illustrative only, and not in a limiting sense, and that accordingly only such limitations should be placed thereon as are specifically expressed in the accompanying claim.

What I claim as my invention is:

A luminaire comprising in combination, a mounting structure, a wiring boxing, and a light-diffusing cell, said mounting structure comprising in combination, a grid lying parallel with and spaced from an adjacent bounding side of an enclosure, means for maintaining said grid so spaced, and at least one cross-bar recessed with respect to the plane of said grid and secured to a part of said mounting structure, said wiring boxing being connected to said cross-bar, and comprising an inverted elongated channel, a posterior reflector anteriorly attached to said channel to close the latter, said light diffusing cell being mounted in said grid and consisting of a posterior, elongated, light-transmitting and shielding panel, a light diffusing presentation panel, and flanking reflector panels connecting said light transmitting and shielding panel, and said presentation panel in spaced relationship, said cell being anterior to and adjacent said posterior reflector, said posterior reflector and said light transmitting and shielding panel at least substantially enclosing a light chamber which projects towards said presentation panel, and means for detachably maintaining said cell mounted as aforesaid.

(References on following page)

3,035,165

5

References Cited in the file of this patent

UNITED STATES PATENTS

2,306,700	Kantack -----	Dec. 29, 1942
2,327,552	Poehling -----	Aug. 24, 1943
2,376,715	Naysmith -----	May 22, 1945
2,423,664	Ryder -----	July 8, 1947
2,428,827	Beck -----	Oct. 14, 1947
2,584,813	Poupitch -----	Feb. 5, 1952

2,588,951
2,694,775
2,701,299
2,717,307
2,728,595
2,740,885
2,748,255
2,802,933

5

6

Anstett -----	Mar. 11, 1952
Florence -----	Nov. 16, 1954
Florence -----	Feb. 1, 1955
Bjontegard -----	Sept. 6, 1955
Wong -----	Dec. 27, 1955
Kruger -----	Apr. 3, 1956
Decker -----	May 29, 1956
Broadwin -----	Aug. 13, 1957