

(19) World Intellectual Property  
Organization  
International Bureau



(43) International Publication Date  
29 December 2004 (29.12.2004)

PCT

(10) International Publication Number  
**WO 2004/113667 A1**

- (51) International Patent Classification<sup>7</sup>: **E21B 7/20**
- (21) International Application Number:  
PCT/EP2004/006182
- (22) International Filing Date: 7 June 2004 (07.06.2004)
- (25) Filing Language: English
- (26) Publication Language: English
- (30) Priority Data:  
0314533.1 23 June 2003 (23.06.2003) GB
- (71) Applicant (for FR only): **SERVICES PETROLIERS SCHLUMBERGER** [FR/FR]; 42, rue Saint Dominique, F-75007 Paris (FR).
- (71) Applicant (for AT, AU, AZ, CO, DE, DK, HR, ID, IE, IT, KP, KR, KZ, MX, NO, NZ, PH, PL, RO, RU, SK, ZA only): **SCHLUMBERGER TECHNOLOGY B.V.** [NL/NL]; Parkstraat 83-89, NL-2514 JG The Hague (NL).
- (71) Applicant (for all designated States except AE, AT, AU, AZ, BR, CA, CG, CM, CN, CO, CZ, DE, DK, DZ, EC, EG, FR, GA, GQ, HR, ID, IE, IN, IT, KP, KR, KZ, LT, MA, MX, NA, NE, NO, NZ, OM, PG, PH, PL, RO, RU, SD, SK, SY, TD, TN, TR, TT, US, VN, ZA): **SCHLUMBERGER HOLDINGS LIMITED**; P.O. Box 71, Craigmuir Chambers, Road Town, Tortola (VG).
- (71) Applicant (for CA only): **SCHLUMBERGER CANADA LIMITED** [CA/CA]; 525 - 3rd Avenue S.W., Calgary, Alberta T2P 0G4 (CA).
- (71) Applicant (for CN only): **SCHLUMBERGER OVERSEAS S.A.** [PA/PA]; 8 Calle Aquilino de la Guardia, Panama City (PA).
- (71) Applicant (for AE, OM, SD, SY, TR only): **SCHLUMBERGER OILFIELD ASSISTANCE LIMITED**; Craigmuir Chambers, Road Town, Tortola (VG).
- (71) Applicant (for BR only): **SCHLUMBERGER SURENCO S.A.** [PA/PA]; 8 Calle Aquilino de la Guardia, Panama City (PA).
- (71) Applicant (for TT only): **SCHLUMBERGER SERVICES LIMITED**; P.O. Box 438, Tortola (VG).
- (71) Applicant (for EG only): **SCHLUMBERGER SEACO INC.** [PA/PA]; 8 Calle Aquilino de la Guardia, Panama City (PA).
- (71) Applicant (for CG, CM, CZ, DZ, EC, GA, GQ, IN, LT, MA, NA, NE, PG, TD, TN, VN only): **PETROLEUM RESEARCH AND DEVELOPMENT NV** [NL/NL]; De Ruyterkade 62, Willemstad, Curacao (AN).
- (72) Inventor; and
- (75) Inventor/Applicant (for US only): **ORBAN, Jacques** [FR/FR]; 12, rue des Quatre Vents, F-92380 Garches (FR).
- (74) Agent: **ETUDES & PRODUCTIONS SCHLUMBERGER**; 1, rue Henri Becquerel - BP 202, 92142 Clamart Cedex (FR).
- (81) Designated States (unless otherwise indicated, for every kind of national protection available): AE, AG, AL, AM, AT, AU, AZ, BA, BB, BG, BR, BW, BY, BZ, CA, CH, CN,

[Continued on next page]

(54) Title: FLEXIBLE DRILL STRING MEMBER

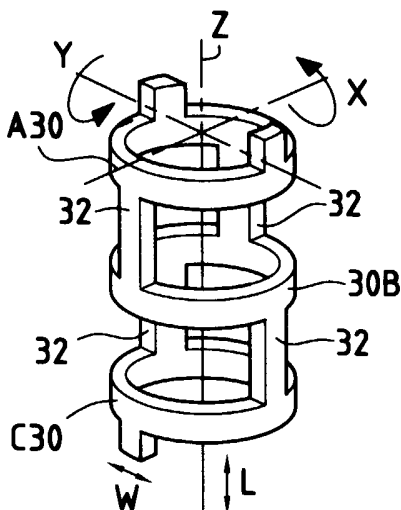

(57) Abstract: A drilling tool that has a flexible shaft so as to be able to make short radius curves while still being able to transmit torque and axial loads. The drilling tool includes a drill shaft for transmitting axial load, comprising a series of coaxial ring members connected together such that adjacent ring members are flexible in an axial plane relative to each other; each ring member being connected to an adjacent ring member by connecting member arranged to transmit torque therebetween; and axial supports extend between adjacent ring members so as to transmit axial loads therebetween.

WO 2004/113667 A1



CO, CR, CU, CZ, DE, DK, DM, DZ, EC, EE, EG, ES, FI, GB, GD, GE, GH, GM, HR, HU, ID, IL, IN, IS, JP, KE, KG, KP, KR, KZ, LC, LK, LR, LS, LT, LU, LV, MA, MD, MG, MK, MN, MW, MX, MZ, NA, NI, NO, NZ, OM, PG, PH, PL, PT, RO, RU, SC, SD, SE, SG, SK, SL, SY, TJ, TM, TN, TR, TT, TZ, UA, UG, US, UZ, VC, VN, YU, ZA, ZM, ZW.

**(84) Designated States** (unless otherwise indicated, for every kind of regional protection available): ARIPO (BW, GH, GM, KE, LS, MW, MZ, NA, SD, SL, SZ, TZ, UG, ZM, ZW), Eurasian (AM, AZ, BY, KG, KZ, MD, RU, TJ, TM),

European (AT, BE, BG, CH, CY, CZ, DE, DK, EE, ES, FI, FR, GB, GR, HU, IE, IT, LU, MC, NL, PL, PT, RO, SE, SI, SK, TR), OAPI (BF, BJ, CF, CG, CI, CM, GA, GN, GQ, GW, ML, MR, NE, SN, TD, TG).

**Published:**

— with international search report

For two-letter codes and other abbreviations, refer to the "Guidance Notes on Codes and Abbreviations" appearing at the beginning of each regular issue of the PCT Gazette.

## FLEXIBLE DRILL STRING MEMBER

The present invention relates to a drilling tool that can be used for drilling of short-radius deviated wells. In particular, the invention relates to a drilling tool with a flexible drill shaft.

In the drilling of oil wells or the like, deviation of the direction of drilling is normally achieved by using a bent housing in the bottom hole assembly (BHA) together with a downhole motor to rotate the drill bit while weight is applied from the surface without rotating the drill string. Alternatively, a rotary steerable system such as the Power Drive system of Schlumberger can be used. Moveable stabilizers are operated from the BHA according to the rotational position of the BHA in the well so as to urge the drill bit in the desired direction. The flexibility in normal steel drill pipe is such that deviations with radius of 150m can be achieved using these techniques.

Coiled tubing can also be used for drilling applications. In such uses a directional drilling BHA is connected to the end of the coiled tubing. One particular tool is the VIPER Coiled Tubing Drilling System (described in Hill D, Nerne E, Ehlig-Economides C, and Mollinedo M "Reentry Drilling Gives New Life to Aging Fields," Oilfield Review (Autumn 1996) 4-14) which comprises a drilling head module with connectors for a wireline cable, a logging tool including a number of sensors and associated electronics, an orienting tool including a motor and power electronics, and an drilling unit with a steerable motor. While the system is provided with power and data via a cable, it is also necessary to provide a coiled tubing to push the tool along the well.

One particular use of such drilling tools, is that of re-entry drilling in which further drilling operations are conducted in an existing well for the purposes of improving production, remediation, etc. A review of such techniques can be found in the Hill et al paper referenced above and in SPE 57459 Coiled Tubing Ultrashort-Radius Horizontal Drilling in a Gas Storage Reservoir: A Case Study; E. Kevin Stiles, Mark W. DeRoeun, I. Jason Terry, Steven P. Cornell, Sid J. DuPuy. By using a double articulated, it was possible in this case to achieve a build rate of 65° per 100 ft with

short sections (5ft) showing build rates of 100° per ft. Starting in a 5 ½ inch “vertical” casing, it was possible to reach horizontal in about 100 ft of vertical depth. It has been possible to achieve deviations of 15m radius using such techniques.

All of the systems described above have physical limitations on the degree of curvature that can be obtained. When attempting to drill out of a cased hole, this means that it is necessary to mill an elongated hole in the casing for the BHA to be able to pass through into the formation around the borehole. Also, the amount of curvature that can be obtained is highly dependent on the type of rock in the formation.

Other techniques have been proposed for drilling laterally from an existing well.

US 6,276,453 discloses a drilling tool including a drill shaft comprising a series of discs which can be guided along a curved path so as to extend laterally from a borehole and to transmit percussion forces to a drill bit at the end thereof. This technique is not applicable to rotary drilling and it is not possible to withdraw the shaft from the hole after drilling.

US 5,687,806 and US 6,167,968 describe a drilling system in which a flexible shaft is used to provide torque to a drill bit and a thrust support causes weight to be applied to the drill bit and to drive the bit a short way into the formation from the borehole. The diameter of the hole drilled and its extent into the formation are small and unsuitable for production of fluids or placement of measurement devices.

It is an object of the present invention to provide a drilling tool that has a flexible shaft so as to be able to make short radius curves while still being able to transmit torque and axial loads.

The present invention provides a drilling tool including a drill shaft for transmitting axial load, comprising a series of coaxial ring members connected together such that adjacent ring members are flexible in an axial plane relative to each other;

characterized in that each ring member is connected to an adjacent ring member by connecting member arranged to transmit torque therebetween; and axial supports extend between adjacent ring members so as to transmit axial loads therebetween.

The connecting members and axial supports preferably allow adjacent ring members to bend in one axial plane while remaining stiff in remaining stiff in another axial plane offset by up to  $90^\circ$  (preferably an orthogonal axial plane). In order to achieve this, the connecting arms and axial supports can be arranged such that the bending plane on one side of a ring member is different, preferably orthogonal, to that on the other side.

The connecting member and axial support can be constituted by the same physical structure, which typically comprises a pair of diametrically opposed axial links extending between circumferentially aligned points on adjacent ring members. The connection point of links extending axially from one side of a ring member are preferably offset from those extending in the axial opposite direction by up to  $90^\circ$ .

The physical structure can also comprise pairs of links extending between connection points on one ring member to connection points on an adjacent ring member circumferentially offset by up to  $90^\circ$ , such that each connection point is connected by a pair of inclined links to the adjacent ring. In one embodiment, the connection points of links extending from one side of a ring member are aligned with those extending in the axial opposite direction.

The connecting member and axial support can also be constituted by separate physical structures. In one such embodiment, the axial support comprises at least two axial links, preferably a pair of diametrically opposed axial links, extending between circumferentially aligned points on adjacent ring members, and the connecting member comprises inter-engaging teeth projecting from the adjacent ring members. The axial support can comprise at least two axial links extending between circumferentially aligned points on adjacent ring members, and the connecting member can comprise a torsion ring extending between the axial links and connected to a torsion link connected to one of the ring members at a point offset by up to  $90^\circ$  from the axial links. In such a case, the part of the axial link extending between the

torsion ring and the ring member to which the torsion link is connected can be substantially more flexible than the part of the axial link extending from the torsion ring to the other ring member.

In another preferred embodiment, the axial support comprises at least two axial links extending between circumferentially aligned points on adjacent ring members, and the connecting member comprises pairs of links extending between connection points on one ring member to connection points on an adjacent ring member circumferentially offset by up to 90°, such that each connection point is connected by a pair of inclined links to the adjacent ring. Each axial link may be connected at one end to one of the ring members, and at the other end separated from the other ring member by a small distance such that when an axial compressive load is applied to the tool, the axial link is contacted by the other ring member.

It is particularly preferred that the tool comprises operable load supports which are moveable between a first position in which they are located between the ring members at points between the axial links and contacted by the ring members when compression is applied so as to resist bending in that direction, and a second position in which they are positioned away from the ring members so as not to be contacted when compression is applied and so not to resist bending in that direction. In one embodiment, the load supports comprise tension latches which, in the first position, are engaged by the ring members when tension is applied, and which, in the second position, are not engaged when tension is applied. The load supports can be normally biased into the first position and can be moved into the second position by application of pressure on a button attached to an outer surface of each load member.

A further embodiment of the drilling tool according to the invention has the axial support is connected at one end to one of the ring members, and at the other end is separated from the other ring member by a small distance such that when an axial compressive load is applied to the tool, the axial support is contacted by the other ring member, and moveable between a first position in which the axial support located between the ring members and contacted by the ring members when compression is applied so as to resist bending in that direction, and a second position in which the

axial support is positioned away from the ring members so as not to be contacted when compression is applied and so as not to resist bending in that direction.

The various functional structures can be defined by providing cutouts in a tubular member.

Adjacent ring members can define a cell that is flexible in an axial plane, and the axial planes in adjacent cells being offset by a predetermined angle of up to 90°. A drilling tool according to the invention can comprise two concentric drill shafts that are rotatable relative to each other, such that when the axial planes of the cells are aligned, the tool can bend in that plane at that position, and when the axial planes of the cells are offset by the predetermined angle, bending of the tool at that point is resisted.

Preferably, a fluid conduit extends along the drill shaft to allow a drilling fluid to be supplied from one end of the shaft to the other.

A drilling assembly including a drill bit can be provided at one end of the shaft and a rotary motor connected to the other end of drill shaft for rotating the drill bit.

This invention provides a drilling shaft (or drill string) for rotary drilling which has a mechanical design allowing to operation either in a "rigid" bending mode or in a "soft" bending mode. The bending stiffness can be set to either rigid or soft bending mode over certain length of the shaft, and in both modes, the shaft allows transmission of the drilling torque when in rotary mode, and transmission of axial load (Weigh On Bit) in rotary or sliding mode: the shaft being resistant to buckling when in rigid mode. However, the shaft can easily comply to the shape of a guiding mechanism when is soft mode. This drilling shaft is a particular benefit while drilling a long straight hole perpendicular to a initially existing larger hole in which a drilling machine for providing a driving force to the shaft is located. As a particular example, this shaft may be useful for drilling lateral hole to a existing well for oil & gas production well.

Rotary drilling of a hole by a drill bit requires the following combination:

- The bit must be rotated at a certain RPM to insure the proper actions of the “cutters”. The cutting action can be either shear or gouging or abrasion.
- The bit must be pushed in contact with the material to drill so that the cutters may interact properly with the material to drill. An axial force must be applied onto the bit. In the oil & Gas drilling industry, this is called Weigh-On-Bit (WOB).
- As a reaction to the WOB (via the friction of the bit), a torque is required to rotate the bit. This torque depends on WOB, RPM, material to drill, and properties of the bit, as well as the potential lubrication action due to some fluid (if present).

Rotation, torque and axial force are typically transmitted onto the bit from a remote point: in most drilling process, rotation and axial force are generated at the other end of the drill shaft by the drilling machine. For example, this is the case when using a hand drill to drill a block of any material.(steel, concrete,...). The shaft needs to have the proper strength (and geometrical inertia) to transmit these drilling requirements. It must resist to the compression of the axial force to the torsion generated by the drilling torque. The torsion resistance is directly link to the geometrical inertia for torsion.

Furthermore, the shaft must resist to buckling. Buckling consists of large sideway deformation due to instability of the structure: these large deformations occur when the compression force is larger that a critical threshold:

$$\text{Critical Force} = \text{Pi}^2 E I_{\text{bending}} / L^2$$

With  $E$  = young modulus

$I_{\text{bending}}$  = Bending inertia

$L$  = length of the unsupported shaft

This is the Euler formula for shaft with free-rotating end supports.

For hollow cylindrical pipe :

$$I_{\text{bending}} = \text{Pi} (D_e^4 - D_i^4) / 64$$

$$I_{\text{torsion}} = \pi (D_e^4 - D_i^4) / 32$$

With  $D_e$  = External Diameter

$D_i$  = Internal Diameter

Above the critical buckling force, large sideway deformation of the drill shaft has several major issues:

- Friction between the shaft and bore-hole. The friction acts against the axial force and against the rotational torque generated at the powering end of the shaft. With this large loss in the hole, it is difficult to optimise the torque and axial load on the bit.
- Risk of self-blocking of the pipe in the well against axial displacement, by the anchoring effect of the pipe against the borehole: This is particularly true in large hole.
- Large pipe deformation. When combined with rotation, this may generate severe fatigue of the pipe.

Consequently, the design of the drill shaft is a compromise:

- 1) The section must be large enough to resist to the axial load

$$\text{WOB} < \pi (D_e^2 - D_i^2) / 4 * \text{yield-stress}$$

- 2) The section inertia must be adequate for the torque (with the following typical formulae)

$$\text{Shear}_{\text{max}} = \text{Yield-stress} / 2 > 0.5 \text{ Torque} * D_e / I_{\text{torsion}}$$

- 3) The shaft must not buckle

$$\text{WOB} < \pi^2 E I_{\text{bending}} / L^2$$

Based on relations 2 & 3, the shaft should have the  $I_{\text{bending}}$  as large as possible. A method to reduce the risk of buckling is to introduce a system of guides for the shaft into the drilled well-bore: the presence of these guides reduces the length of buckling. This is typically performed in the drill string for oil & gas well drilling by the use of stabilizers within the section of the string in compression.

- 4) The drill shaft must be compatible with the removal (or lifting) of drilled cuttings in the annulus between the shaft and the borehole wall. For this reason, the shaft has

to have an external diameter smaller than the hole diameter. This is the first limit to the pipe inertia. Furthermore, the pipe may have to be hollow to pump fluid (drilling mud) for, inter alia, cuttings removal and transport in the annulus. The presence of the bore in the pipe reduces slightly the pipe inertia.

5) The main motivation to reduce bending inertia is to insure compatibility with "directional drilling". In some industries, the drilled hole must follow complex trajectory. In other applications, the drill shaft is bent between the powering machine and the bit (a common application is the use of flexible shaft between hand-drilling tool and small bit). For these situations, the shaft must have a low bending inertia. This is directly in conflict with the criteria of torque transmission: the bending inertia and the torsion inertia are only different by a factor of 2 (for a cylindrical shaft). Furthermore, low bending inertia reduce the buckling performance.

As explained previously, a flexible shaft may be required in some drilling applications where the shaft is not operating as a straight structure, but in bent shape. Metal cables are often used for this purpose. It can be shown, that a tube under torsion load is submitted to shear stress in the cross section. By mathematical treatment, principal stresses can be shown to be tangential to the cylindrical surface at  $45^\circ$  from the main axis (one in compression, the other one in tension). Therefore, the cable typically has wires wrapped in multiple layers: the individual wires being typically at  $45^\circ$  from the main axis. This angle is  $+45^\circ$  and  $-45^\circ$ , alternately from layer to layer. Normally, the external layer is laid with the wires supporting tension load to avoid buckling of the wire under the tension generated by the drilling torque. If the external layer is laid with the wire in compression, it can deform towards the outside, making a bulge in the cable. The buckling of the individual strands typically occurs at low loads as each wire strand has a small diameter (which means an extremely small buckling survival capability).

Cables, when used as drilling shaft, have limited capability to transmit axial load to push the bit (WOB), as a cable has a low bending inertia. This apparent low inertia of the cable is due to the fact that a wire describes a spiral around the main axis. When the cable is flexed and due to the strand spiral, a wire strand is alternately in extension (when on the outside of the curve), and in compression when on the inside of the

curve. If there were no friction between the wire strands of the cable, the wire strands would move slightly and would keep their initial length even though the cable is curved, while providing no reaction force (or momentum) against the imposed bending on the cable.

As an example in the ideal case (all wire strands are bent at the same rate; no friction between wire strands), a cable inertia would then be:

$$I_{\text{bending\_cable}} = N I_{\text{bending-strand}}$$

$N$  = number of strands in the cable.

In the best case, (no void between strands)

$$\text{Section}_{\text{cable}} = N \text{ section}_{\text{strand}}$$

Combining these 2 relations, we obtain:

$$I_{\text{solid\_tube}} / N = I_{\text{bending\_cable}}$$

This relationship shows that a solid tube has a higher bending stiffness than a cable. The cable stiffness reduces quickly when the number of strands increase (for a given cable diameter).

For some flexible drilling cables as used with hand drilling tool, axial load is transmitted by the flexible non-rotating guide hose around the flexible rotating cable. Axial load is transmitted from the guide hose onto the bit at the extremity of the flexible drilling assembly via a thrust bearing system.

In other applications (see, for example, US 5,687,806 and US 6,167,968), the cable is guided by a fixed curved structure for most of the length of the cable. The cable is left unsupported in the radial direction only for short distance.

Directional drilling is common practice during drilling of oil & gas wells. For this purpose, the drill-string extends from the surface (drilling rig) down to the bit. In most conventional drilling, only a short section of the drill-string above the bit is in compression (due to its own weight) to generate axial force onto the bit. Most of the

string is in tension to avoid buckling. The section in compression is kept short thanks to the use of heavy pipe called drill-collar. Furthermore, buckling is limited as this section can be guided in the hole by stabilizers that limit sideways displacement.

In case of horizontal wells, the pipe in the horizontal section of the well is in compression under the effect of the weight of heavy pipe in the inclined or vertical section of the well. In this situation, the drill-string in the horizontal section may be buckled.

In the curved section of the well (between sections of different direction or inclination), the pipe is bent. This bending generates stresses which may become fatigue when the pipe is in rotation. To limit fatigue (and the associated risk of rupture), bending stress should be limited: this requires low inertia pipe. Such a requirement may be in conflict with the need to delay buckling in the horizontal section. Furthermore sufficient inertia is required to transmit the drilling torque to the bit.

So, a drill string for oil & gas well drilling is a compromise of inertia to insure adequate performances. Drill-collar (higher inertia) often suffers from fatigue when rotated in the curved section of the well.

Lateral drilling is becoming common in the oil & gas industry, in which lateral holes are drilled from a main "vertical" hole. In most cases, a lateral hole is drilled with techniques similar to directional drilling. Special processes and equipment may be needed to start the kick-off from the main hole: retrievable whipstocks are one possible approach. Conventional directional drilling equipment can only pass through a certain radius. Even in the most aggressive process, the radius of the curve cannot be smaller than 15 meters. This means that the intersection between the lateral hole and the main well becomes a long ellipse. This ellipse may decrease drastically the stability of the main hole.

In the oil & gas industry, wireline-conveyed drilling tools have been introduced to drill at right-angles from the main hole. This method can be used to drill small channels or drains perpendicular to main hole which can replace perforations which are

conventionally made with shaped charges. Other tools can drill perpendicularly in the casing and the cement behind the casing to allow measurement of formation pressure. Some tools have also been proposed to drill fairly long perpendicular hole to insure larger production.

The present inventions will now be described in relation to the accompanying drawings, in which:

Figure 1 shows a general view of a drilling system incorporating the present invention;

Figures 2a and 2b show a first embodiment of a drill shaft according to the invention;

Figure 3 shows a second embodiment of a drill shaft according to the invention;

Figures 4a and 4b show a third embodiment of a drill shaft according to the invention;

Figure 5 shows a fourth embodiment of the invention;

Figure 6 shows a fifth embodiment of the invention;

Figure 7 shows a modified version of the embodiment of Figure 6;

Figure 8 shows a sixth embodiment of the invention;

Figure 9 shows a modified version of the embodiment of Figure 8;

Figure 10 shows another modification of the embodiment of Figure 8;

Figure 11 shows an embodiment of the invention including the features shown in Figures 8, 9 and 10;

Figure 12 shows a seventh embodiment of the invention;

Figure 13 shows one particular implementation of the seventh embodiment; and

Figure 14 shows a drilling system incorporating the embodiments of Figures 12 and 13.

The present invention concerns a drill shaft which can be operated at two different bending stiffnesses. This drill shaft can therefore be used with a drilling machine mounted at some angle from the axis of the hole to be drilled. A typical application is lateral drilling in oil & gas business. In this application, a main well 10 is already drilled and the drilling machine 12 is installed in the main hole 10 (figure 1). Rotation is applied to the drill shaft 14 on an axis parallel to that of the main hole 10 by means of a drilling motor 16 having a rotation head that is also parallel to the main hole axis.

The drill shaft 14 passes across a guide device (or section or system) 18 to be bent and aligned with the axis of the lateral hole 20. This change of direction is performed while the shaft 14 is rotated and advanced by a suitable pushing system 22 in the drilling machine 12. Rotation and axial motion are transmitted to the drill bit 24 at the end of the drill shaft 14 to cut more hole. Over the section 26 where direction is being changed, the shaft 14 is in compression, torsion and bending. To permit this combination, low bending inertia is needed to allow short radius turn. However, in the straight section 20 the shaft 14 should be stiff to avoid buckling. This is particularly critical when a long lateral hole 20 is to be drilled.

In the shaft according to the invention, torsion inertia in the shaft is decoupled from bending inertia, such that the bending inertia can be low while passing a curved section and high while drilling a straight section. In most applications, high torque application is required to drive the bit. However if sharp turn is required between the main hole and the laterally-drilled hole, the shaft should be extremely flexible.

Hollow tube normally couples the tube inertias (bending / torsion). In this invention, a hollow tube is modified by radial grooves to become effectively a stack of rings 30 (Figure 2a). The rings 30 are attached together by straight links 32 which allow high bending flexibility. Due to the use of two links 180° around the shaft 14, the shaft 14 can only bend around the bending axis X, Y perpendicular to the shaft axis Z passing through both links 32 between the adjacent rings A, B or B, C. By placing the links 32 in various azimuthal planes (around the shaft axis Z), it is possible to distribute the shaft bending direction between rings. In the shown example (Figure 2a), the link azimuth is rotated by 90° for each set of rings (the links between rings A and B are at 90° from the links between rings B and C). This combination allows the shaft 14 to bend in all directions.

With this simple design, bending depends on the width W and length L of the link 32. The torque capability of the shaft 14 is determined by the section (thickness T x width W) multiplied by the radius of the shaft 14. Axial load (such as WOB) can also be transmitted by the links 32.. With this design, the shaft can be based on a thick-walled tube cut with wide grooves so that the link width is limited for easy bending. The wall thickness will allow the links 32 to transmit high torque. The rings 30 have to be thick

enough to support WOB (or axial pull) without deformation as the links of successive rows are rotated by  $90^\circ$ . The properties of the links 32 to allow bending of the shaft 14 must also be balanced against the need to resist collapse under buckling (not too narrow, not too long)

The tendency of the links to form a double bend 32' under torque (Figure 2b) is a torque limitation of the system, to avoid link failure.

One modification to limit the double bending of the links 32 under torque is to equip the rings 30 with a direct method for torque transmission. One such method is to equip the rings 30 with two sets of teeth 34, 34' as shown in Figure 3. These act as teeth and spline of collapsible shaft which can take torsional load.

In the next proposed structure (Figure 4a), the torque capability is improved by the use of a torsion ring 36. This torsion ring 36 is a thin disk attached to the main rings 30 by main links 38  $180^\circ$  apart. There is a  $90^\circ$  angular shift between the main links 38, 38' on both faces of the same torsion ring 36. With this structure, torque can be transmitted from successive shaft rings 30 (for example, from ring A to ring B) while at the same time being inclined thanks to the high flexibility of the torsion ring 36 in its own plane. This structure allows torque transmission under shaft bending.

The proposed structure is not uniform over its length. The torsion ring 36 is attached also by two small links 40 parallel to the shaft on the lower side of the torsion ring 36. These two additional links 40 ensure a pre-defined distance between successive main rings 30. They allow the transmission of axial load (shaft tensile or compressive load) with little or no reduction of distance between the successive rings. These additional axial links 40 are narrow (small angular coverage) so that they can bend in the tangential planes of the shaft 14. Thanks to this low bending resistance, the shaft 14 can easily bend in that direction (as there is NO equivalent additional link at  $90^\circ$  above the torsion ring). The torsion rings 36 flex out of their plane when the axial links 40 bends.

To ensure bending in both directions, the link structure is repeated over the shaft length, but at each repetition, the structure is rotated by  $90^\circ$  (see rings A&B and rings

B&C). Other rotation angles could obviously be used, especially to achieve bending in all directions.

With this structure, the shaft can transmit high torque while being flexible and still capable to transmit axial load (tension & compression). High bending flexibility can be achieved by ensuring that the axial links 38 cover most of the shaft length. This can be achieved by providing slots 42 running in the large attachment of the torque ring (see Figure 4b).

A direct modification of this system is shown in Figure 5. In this structure, the successive rings 30 are held together by four inclined (tilted) links 44, adjacent links having opposite angles of inclination. When the shaft bends, successive rings 30 become non-parallel by flexing the inclined links 44. Axial loads (compression, tension) can be transmitted from ring to ring via the inclined links 44. However, the axial force in the inclined links 44 is increased (compared to the shaft axial load) due to the angle of inclination. Care must therefore be taken to avoid buckling of the links 44 under compression either due to the torque or shaft bending. This structure is flexible in all directions.

Figure 6 shows an improved structure compared to Figure 5. By virtue of the addition of two axial links 46 (at  $180^\circ$ ), the strength of the structure is substantially increased for axial loads. With this embodiment, the axial links 46 bend when the shaft bends. As with the embodiments of Figures 2, 3, 4 and 4b, the shaft can only bend by rotating around the axis passing both axial links. The shaft is therefore constructed of successive link cells rotated by  $90^\circ$  (as already explained for the structure of Figures 2 & 4 above).

Figure 7 is a modification of the embodiment shown in Figure 6. The axial link 48 is detached from the ring 30 at one end 50, but is separated therefrom by a very small distance. This small separation allows the link 48 to take axial load only when the system is in compression and deforms enough for the ring 30 to contact the end 50. The axial link 48 does not bend when the shaft bends. With this system, the shaft can only bend by rotating around the axis passing through both axial links 48. In drill-string applications, the compression forces are typically higher than the tension forces

on the drill string so the lack of structural reinforcement by the link 48 in tension is not so significant.

In Figures 6 and 7, the basic cell structure (two successive rings 30) has different bending stiffness at 90°. There is a rigid direction (due to the axial link 46, 48) and a soft direction at 90° thereto.

Figure 8 shows another modified version of the embodiment shown in Figure 6. In the soft plane, two removable compression load supports 52 can be positioned between the rings 30. When so positioned, these removable load supports 52 prohibit bending in the soft plane. The supports 52 are held in position by spring mountings 54 allowing the supports to be pushed out of the support position into a neutral position in which they cannot contact the rings 30. In the embodiment shown, the supports 52 can be pushed towards the centre of the shaft, but other movements are possible. With this structure, the basic cell is normally stiff in all directions, but with a minimum local intervention (i.e. by moving the supports 52 against the action of the springs 54), the rigidity in one plane can be suppressed so as to create a temporary soft plane for bending.

Figure 9 combines the concepts described in Figure 7 & 8. In this case, four axial load supports 56, 56' are used. These are attached only at one end (similar to the axial links 48 of Figure 7) alternately to the upper and lower rings. When normally aligned, they prohibit any reduction of spacing between the rings such that the shaft is stiff in all directions. By pushing away one of these supports 56, 56', the shaft can immediately bend in that direction. Pushing of the supports 56, 56' out of their normal positions can be achieved by use of a button 58 on the outer surface of each support. When passing through the bending guide 18 of the drilling machine 12 (see Figure 1), the guide 18 pushes on these buttons (on the inside of curve 26) allowing the shaft to bend. As soon as the shaft is out of the bending section 18 of the drilling machine 12, the supports 56, 56' remain in their normal positions and the shaft becomes stiff again.

In Figure 10, the embodiment of Figure 8 is modified by the addition of tension latch 60 on load supports 52. The latches 60 allow the supports 52 to resist both

compression and tension loads. When in place, the supports 52 with the latches 60 make the shaft more resistant to bending in the "soft plane". Furthermore, the shaft can resist higher axial pull when the load supports 52 are in their normal position as they can take part of the shaft tension load.

Figure 11 shows a structure which embodies features of Figures 8, 9 and 10. For ease of understanding, the shaft is shown unwrapped as it would be if constructed from one sheet of metal which is be rolled and jointed (welded). The basic structure is one of includes links 44 and axial links 46 as before. A latch 62 connected to the ring 30 by a spring mounting 64 is provided with formations which engage lock structures (described in more detail below) fixed to the adjacent rings 30 (e.g. A & B). A push button 66 is provided on the outer surface each latch 62 to operate in the manner as described above in relation to Figure 9, i.e. in the normal position, the shaft is in stiff mode, operation of the button moves the latch 62 out of its normal position into a soft mode. The latch 62 includes upper and lower outer abutment surfaces a, b which are close to, but separated from, the adjacent rings (e.g. B & C). In compression, distortion of the structure causes the formations a, b to contact the rings B, C such that the latch forms an axial load support. Upper and lower tension locks 68, 70 with opposed lock structures extend from each side of a ring 30 (e.g. C & D). Each latch 62 extends between the tension locks 68, 70 and is provided with inner abutment surfaces c, d which are positioned adjacent the lock structures. In tension, adjacent rings 30 (e.g. C & D) move apart slightly due to distortion of the structure such that the inner abutment surfaces c, d engage the lock structures on the tension locks 68, 70 and the latch forms a tension load support. The exact for of structure for compression and tension support can be varied around the principles shown here. As is described above, the latch is moved to an inoperative position when pressure is applied to the button 66 such that it provided no support in either tension or compression and the shaft is placed in a soft mode.

Figure 12 shows a different embodiment of the invention which uses shafts with successive cells which allow bending in only one direction, but with successive angular de-phasing of the bending direction from cell to cell. In this case, two shafts 72, 74 are used. One shaft 72 has a slightly larger inner diameter than the outer diameter of the other shaft 74 such that the smaller shaft can sit inside the larger one.

When so arranged, if the bending cells of both shafts 72, 74 are “in phase” (the axial links of both shafts are aligned for each section), bending is relatively easy as both shafts allow for corresponding bending in each cell. If, on the other hand, the shafts are out of phase by  $90^\circ$  rotation, bending of the drill-string assembly becomes relatively difficult, since for each cell in a shaft allowing bending, the corresponding cell of the other shaft resists bending due to its  $90^\circ$  de-phasing. With this technique, it is obvious that the overall shaft stiffness depends on a  $90^\circ$  rotation between the two shafts 72, 74. Each shaft 72, 74 can be constructed according to the principle shown in Figures 2 – 4 and described above.

Figure 13 shows a particular implementation of the technique generally described in Figure 12 above. In this case, the rigidity of drill-string assembly is increased by the presence of wings 76, 78 extending outwardly from the axial links of the inner shaft 74, and inwardly from the axial links of the outer shaft 72 respectively. The wings 76, 78 of one shaft extend between the rings 80, 82 of the other shaft. When the two shafts 72, 74 are out of phase by  $90^\circ$ , the wings 76, 78 of one shaft directly support the middle part of the rings 80, 82 of the other and prohibit any displacement of these rings (which means that the shaft cannot bend). This arrangement is shown as configuration A of Figure 13. When the shafts are rotated by approximately  $90^\circ$ , the wings 76, 78 do not support the mid points of the rings 80, 82 and bending is allowed. This arrangement is shown as configuration B of Figure 13.

Figure 14 shows one implementation of the embodiment of Figures 12 and 13 in a drilling system of the general type described in relation to Figure 1 above. In this case, the external shaft 84 is formed as several separate segments. As shown in Figure 14, each segment is a few times longer than the bending guide 18. This allows the setting of the drill string assembly into soft mode only when passing over the guide 18 inside the drilling tool. When the drill-string is in straight sections such as in the main bore-hole 10 or in the lateral hole 20, the shaft assembly is set in rigid mode. Normally, only one or two external segments 84' are rotated at a given time to insure the soft mode.

The rotation of the external shaft 84 to insure the desired bending mode setting can be performed by various mechanisms. In the embodiment shown in Figure 14, the end of

each segment 84 of the external shaft is equipped with a small stabilizer 86 which comprises outward protrusions from the segment. The stabilisers 86 cause drag against the borehole wall during drill-string rotation. Under this rotational drag, the external segments 84 have a tendency to lag behind the internal shaft 88 that drives the rotation of the system. A mechanical stop (not shown) ensures that the angular lag can be  $90^\circ$  at most. In this position, the shaft assembly is in rigid mode (as both the inner shaft 88 and the adjacent segment 84 are out of phase by  $90^\circ$ ). The external shaft segment 84' engaged in the guide 18 is caused to rotate relative to the inner shaft 88 such that it is positioned to allow bending. This rotation can be achieved using a friction wheel 90 positioned in the upper part of the guide 18 which tends to rotate the external shaft segment 84' in the guide 18 at a higher rotation than the inner shaft 88.

Any of the drill-string structures described above can be lined with a flexible hose to allow fluid to be pumped through the drill-string.

It will be apparent that certain changes can be made to the described systems while remaining within the scope of the invention. For example, where flexibility is achieved by bending of structural members, the same result can be achieved by the use of relatively stiff member with appropriate pivot joints. Also, the embodiments above have bending planes offset by  $90^\circ$ . It is also possible that angles of less than  $90^\circ$  could be used. In such a case, the number of ring cells required to obtain full bending freedom will be greater depending on the actual angle used. Also, the number and position of links and connecting members between each pair of rings may be different to that described above.

## CLAIMS

- 1 A drilling tool including a drill shaft for transmitting axial load, comprising a series of coaxial ring members connected together such that adjacent ring members are flexible in an axial plane relative to each other; characterized in that:
  - each ring member is connected to an adjacent ring member by connecting member arranged to transmit torque therebetween; and
  - axial supports extend between adjacent ring members so as to transmit axial loads therebetween.
- 2 A drilling tool as claimed in claim 1, wherein the connecting member and axial supports allow adjacent ring members to bend in one axial plane while remaining stiff in another axial plane offset by up to 90°.
- 3 A drilling tool as claimed in claim 2, wherein the connecting arms and axial supports are arranged such that the bending plane on one side of a ring member is different to that on the other side.
- 4 A drilling tool as claimed in claim 2 or 3, wherein the connecting member and axial support are constituted by the same physical structure.
- 5 A drilling tool as claimed in claim 4, wherein the physical structure comprises at least two axial links extending between circumferentially aligned points on adjacent ring members.
- 6 A drilling tool as claimed in claim 5, wherein the connection point of links extending axially from one side of a ring member are offset from those extending in the axial opposite direction by up to 90°.
- 7 A drilling tool as claimed in claim 4, wherein the physical structure comprises pairs of links extending between connection points on one ring member to connection points on an adjacent ring member circumferentially offset by up

- to 90°, such that each connection point is connected by a pair of inclined links to the adjacent ring.
- 8 A drilling tool as claimed in claim 7, wherein the connection points of links extending from one side of a ring member are aligned with those extending in the axial opposite direction.
- 9 A drilling tool as claimed in claim 2 or 3, wherein the connecting member and axial support are constituted by separate physical structures.
- 10 A drilling tool as claimed in claim 9, wherein the axial support comprises at least two axial links extending between circumferentially aligned points on adjacent ring members, and the connecting member comprises inter-engaging teeth projecting from the adjacent ring members.
- 11 A drilling tool as claimed in claim 10, wherein the axial support comprises at least two axial links extending between circumferentially aligned points on adjacent ring members, and the connecting member comprises a torsion ring extending between the axial links and connected to a torsion link connected to one of the ring members at a point offset by up to 90° from the axial links.
- 12 A drilling tool as claimed in claim 11, wherein the part of the axial link extending between the torsion ring and the ring member to which the torsion link is connected is substantially more flexible than the part of the axial link extending from the torsion ring to the other ring member.
- 13 A drilling tool as claimed in claim 9, wherein the axial support comprises at least two axial links extending between circumferentially aligned points on adjacent ring members, and the connecting member comprises pairs of links extending between connection points on one ring member to connection points on an adjacent ring member circumferentially offset by up to 90°, such that each connection point is connected by a pair of inclined links to the adjacent ring.

- 14 A drilling tool as claimed in claim 13, wherein each axial link is connected at one end to one of the ring members, and at the other end is separated from the other ring member by a small distance such that when an axial compressive load is applied to the tool, the axial link is contacted by the other ring member.
- 15 A drilling tool as claimed in claim 13, further comprising operable load supports which are moveable between a first position in which they are located between the ring members at points between the axial links and contacted by the ring members when compression is applied so as to resist bending in that direction, and a second position in which they are positioned away from the ring members so as not to be contacted when compression is applied and so not to resist bending in that direction.
- 16 A drilling tool as claimed in claim 15, wherein the load supports comprise tension latches which, in the first position, are engaged by the ring members when tension is applied, and which, in the second position, are not engaged when tension is applied.
- 17 A drilling tool as claimed in claim 15 or 16, wherein the load supports are normally biased into the first position and can be moved into the second position by application of pressure on a button attached to an outer surface of each load member.
- 18 A drilling tool as claimed in claim 14, wherein the axial support is connected at one end to one of the ring members, and at the other end is separated from the other ring member by a small distance such that when an axial compressive load is applied to the tool, the axial support is contacted by the other ring member, and moveable between a first position in which the axial support located between the ring members and contacted by the ring members when compression is applied so as to resist bending in that direction, and a second position in which the axial support is positioned away from the ring members so as not to be contacted when compression is applied and so as not to resist bending in that direction.

- 19 A drilling tool as claimed in any preceding claim, wherein the various functional structures are defined by providing cutouts in a tubular member.
- 20 A drilling tool as claimed in any preceding claim, wherein adjacent ring members define a cell that is flexible in an axial plane, and the axial planes in adjacent cells are offset by a predetermined angle of up to 90°.
- 21 A drilling tool as claimed in claim 20, comprising two concentric drill shafts that are rotatable relative to each other such that when the axial planes of the cells are aligned, the tool can bend in that plane at that position, and when the axial planes of the cells are offset by the predetermined angle, bending of the tool at that point is resisted.
- 22 A drilling tool as claimed in any preceding claim, further comprising a fluid conduit extending along the drill shaft to allow a drilling fluid to be supplied from one end of the shaft to the other.
- 23 A drilling tool as claimed in any preceding claim, comprising a drilling assembly including a drill bit at one end of the shaft.
- 24 A drilling tool as claimed in claim 23, further comprising a rotary motor connected to the drill shaft for rotating the drill bit.

1/4

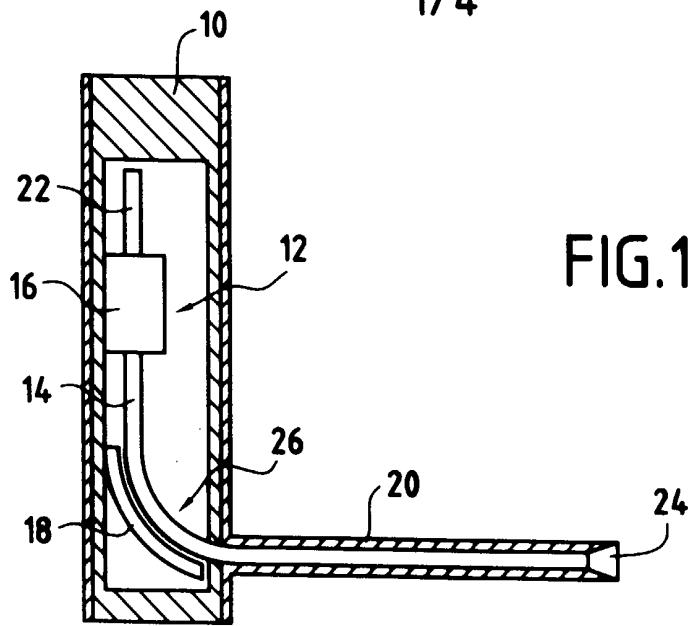

FIG. 1

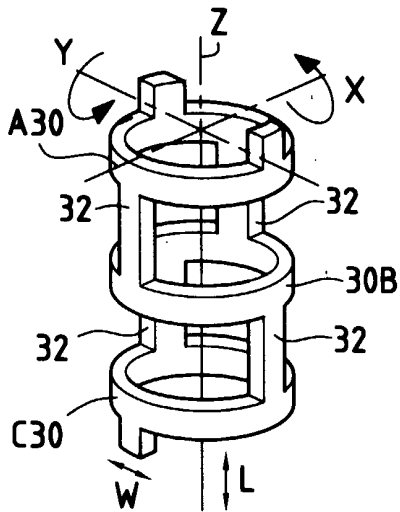

FIG. 2A

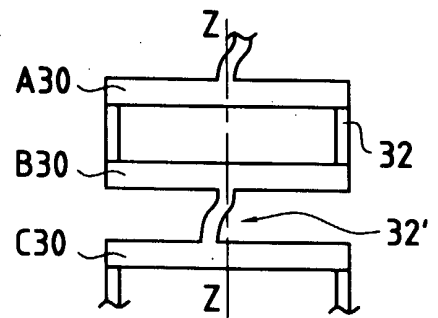

FIG. 2B

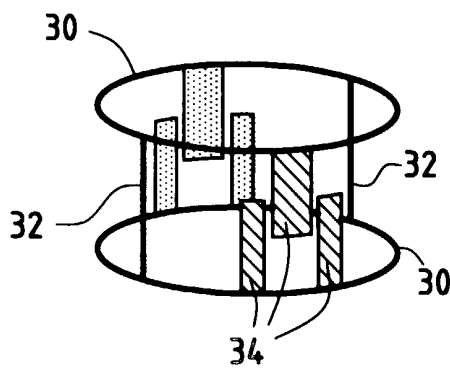

FIG. 3

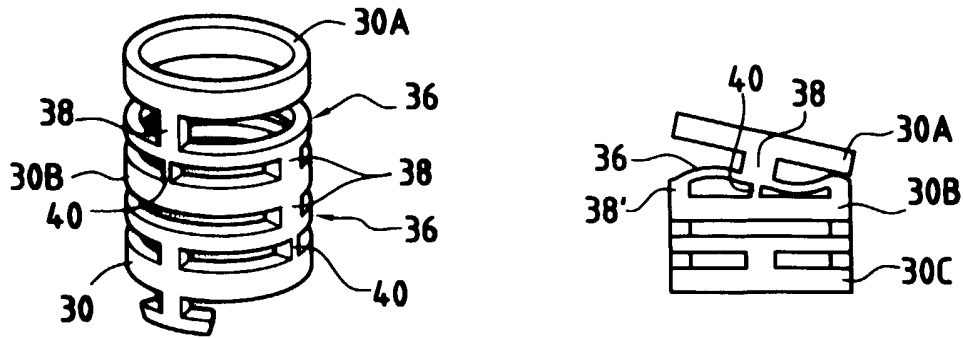

FIG. 4A

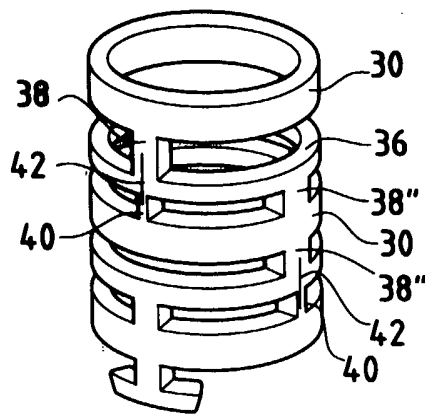

FIG. 4B

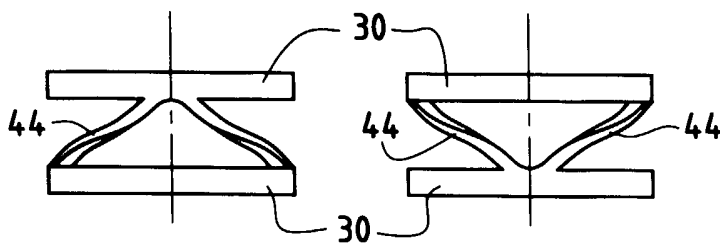

FIG. 5

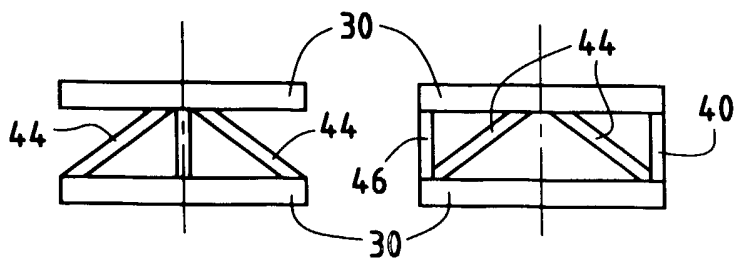

FIG. 6

3/4

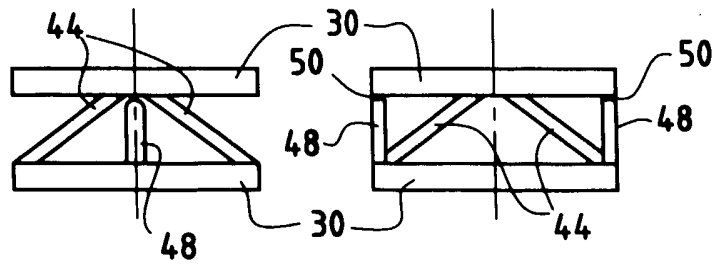

FIG. 7

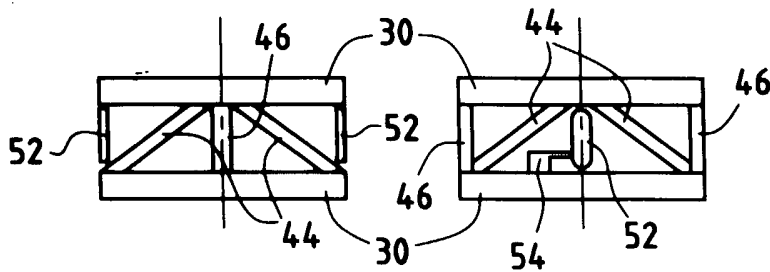

FIG. 8

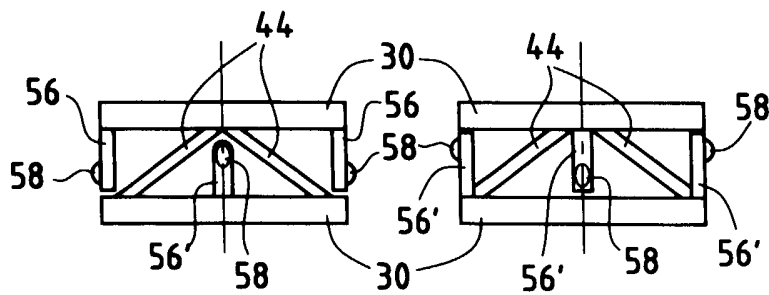

FIG. 9

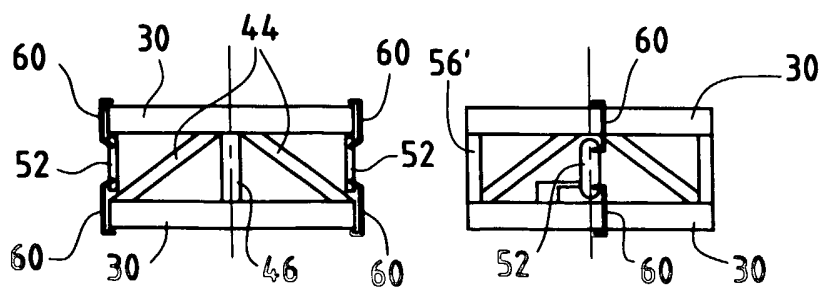
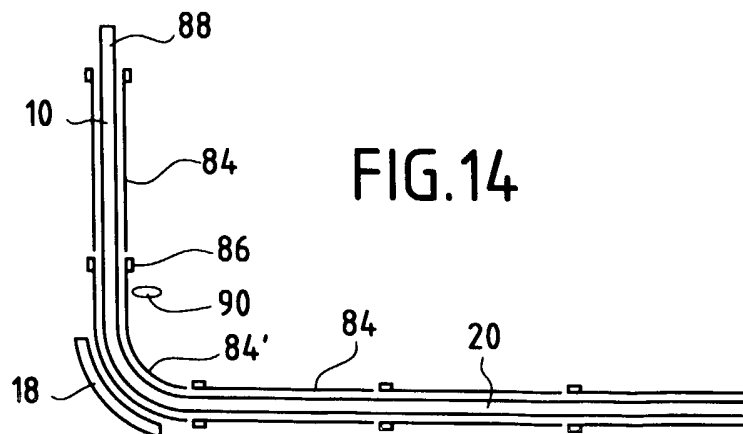
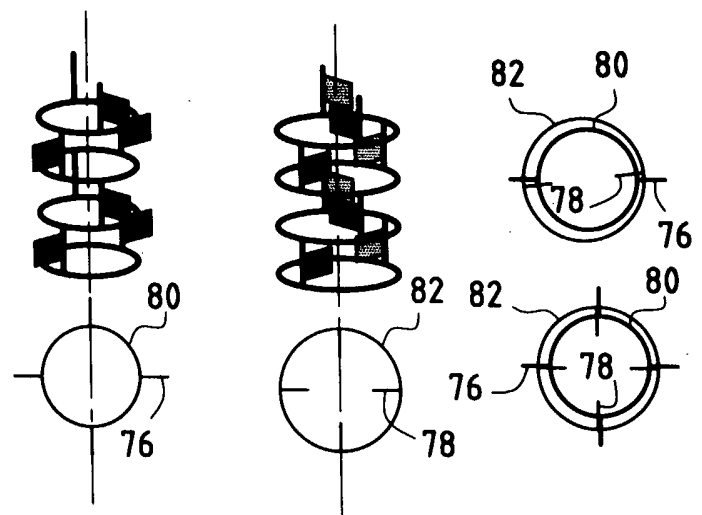
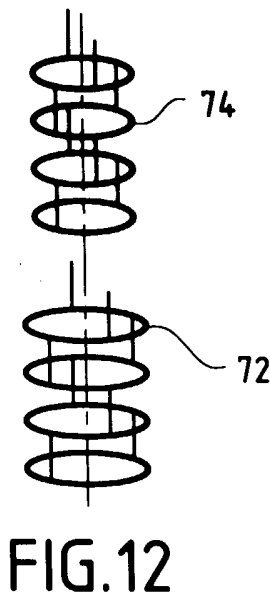
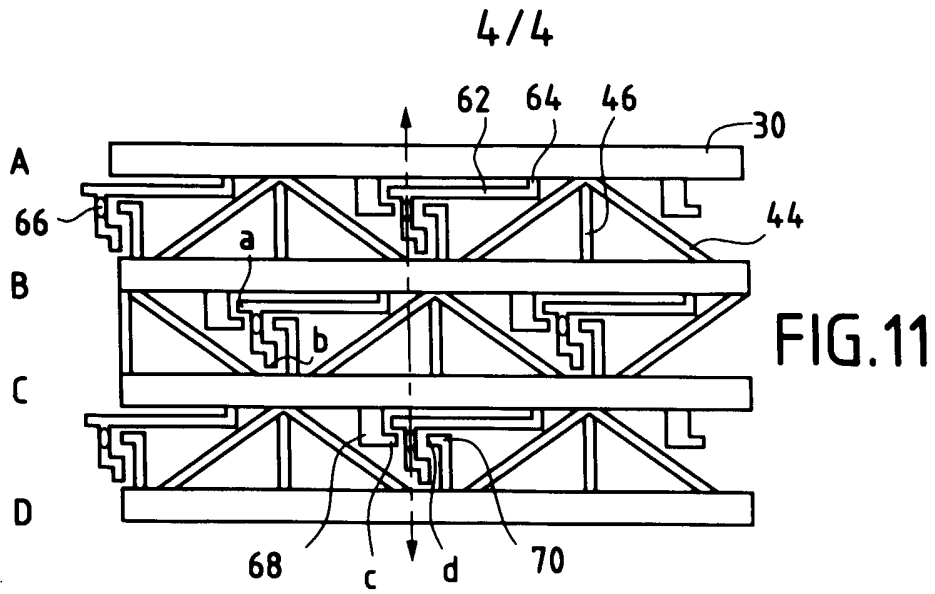

FIG. 10



INTERNATIONAL SEARCH REPORT

International Application No  
PCT/EP2004/006182

**A. CLASSIFICATION OF SUBJECT MATTER**  
IPC 7 E21B7/20

According to International Patent Classification (IPC) or to both national classification and IPC

**B. FIELDS SEARCHED**

Minimum documentation searched (classification system followed by classification symbols)  
IPC 7 E21B

Documentation searched other than minimum documentation to the extent that such documents are included in the fields searched

Electronic data base consulted during the international search (name of data base and, where practical, search terms used)  
EPO-Internal

**C. DOCUMENTS CONSIDERED TO BE RELEVANT**

Category *	Citation of document, with indication, where appropriate, of the relevant passages	Relevant to claim No.
X	US 5 503 236 A (TIBBITTS GORDON A) 2 April 1996 (1996-04-02) column 11, lines 40-49 column 12, lines 6-8 figure 8	1-8, 19, 20, 22-24
A	US 4 226 288 A (COLLINS JR EARL R) 7 October 1980 (1980-10-07) figure 10	1
A	US 5 135 060 A (IDE RUSSELL D) 4 August 1992 (1992-08-04) figures 13-15	1
A	US 2002/134586 A1 (BAIRD BILLY CARR) 26 September 2002 (2002-09-26) the whole document	1

Further documents are listed in the continuation of box C.  Patent family members are listed in annex.

\* Special categories of cited documents:

*A* document defining the general state of the art which is not considered to be of particular relevance	*T* later document published after the international filing date or priority date and not in conflict with the application but cited to understand the principle or theory underlying the invention
*E* earlier document but published on or after the international filing date	*X* document of particular relevance; the claimed invention cannot be considered novel or cannot be considered to involve an inventive step when the document is taken alone
*L* document which may throw doubts on priority claim(s) or which is cited to establish the publication date of another citation or other special reason (as specified)	*Y* document of particular relevance; the claimed invention cannot be considered to involve an inventive step when the document is combined with one or more other such documents, such combination being obvious to a person skilled in the art.
*O* document referring to an oral disclosure, use, exhibition or other means	*Z* document member of the same patent family
*P* document published prior to the international filing date but later than the priority date claimed	

Date of the actual completion of the international search <b>5 August 2004</b>	Date of mailing of the international search report <b>17/08/2004</b>
---	---

Name and mailing address of the ISA European Patent Office, P.B. 5818 Patentlaan 2 NL - 2280 HV Rijswijk Tel. (+31-70) 340-2040, Tx. 31 651 epo nl, Fax: (+31-70) 340-3016	Authorized officer <b>Schouten, A</b>
--	--

# INTERNATIONAL SEARCH REPORT

Information on patent family members

International Application No

PCT/EP2004/006182

Patent document cited in search report	Publication date	Patent family member(s)	Publication date	
US 5503236	A	02-04-1996	BE 1012191 A5 GB 2281577 A , B US 5595254 A US 5671816 A	04-07-2000 08-03-1995 21-01-1997 30-09-1997
US 4226288	A	07-10-1980	NONE	
US 5135060	A	04-08-1992	CA 2061784 A1 DE 4206974 A1 GB 2253462 A	07-09-1992 10-09-1992 09-09-1992
US 2002134586	A1	26-09-2002	US 2002020562 A1 US 6378629 B1 US 2004007391 A1 US 2002108787 A1	21-02-2002 30-04-2002 15-01-2004 15-08-2002