



- (51) International Patent Classification: *H04R 1/02* (2006.01)
- (21) International Application Number: PCT/US2019/012816
- (22) International Filing Date: 09 January 2019 (09.01.2019)
- (25) Filing Language: English
- (26) Publication Language: English
- (30) Priority Data: 62/615,038 09 January 2018 (09.01.2018) US
- (71) Applicant: **DGL GROUP USA** [US/US]; 195 Raritan Center Parkway, Edison, New Jersey 08837 (US).
- (72) Inventors: **LINIADO, Marc**; 716 Avenue N, Brooklyn, New York 11230 (US). **KOHLSMITH, Andrew**; 209-1652 Bathurst Street, Toronto, Ontario M5P3J9 (CA).
- (74) Agent: **JAKETIC, Bryan**; 275 Battery Street, Suite 2600, San Francisco, California 94111 (US).
- (81) Designated States (*unless otherwise indicated, for every kind of national protection available*): AE, AG, AL, AM, AO, AT, AU, AZ, BA, BB, BG, BH, BN, BR, BW, BY, BZ, CA, CH, CL, CN, CO, CR, CU, CZ, DE, DJ, DK, DM, DO, DZ, EC, EE, EG, ES, FI, GB, GD, GE, GH, GM, GT, HN, HR, HU, ID, IL, IN, IR, IS, JO, JP, KE, KG, KH, KN, KP, KR, KW, KZ, LA, LC, LK, LR, LS, LU, LY, MA, MD, ME, MG, MK, MN, MW, MX, MY, MZ, NA, NG, NI, NO, NZ, OM, PA, PE, PG, PH, PL, PT, QA, RO, RS, RU, RW, SA, SC, SD, SE, SG, SK, SL, SM, ST, SV, SY, TH, TJ, TM, TN, TR, TT, TZ, UA, UG, US, UZ, VC, VN, ZA, ZM, ZW.

(54) Title: EXPANDABLE SPEAKER SYSTEM AND METHOD FOR BROADCAST

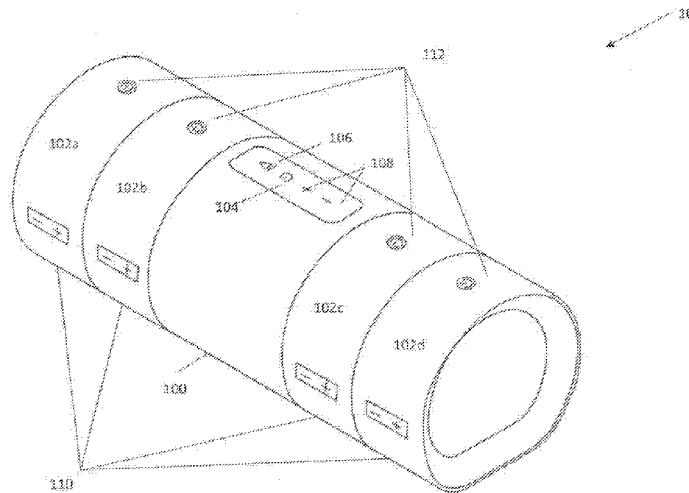

Figure 1

(57) Abstract: An expandable wireless speaker system and method is disclosed. The speaker system comprises a center module and at least two or more speakers. The center module has a unique identification number and has mechanical connections on at least one side. The center module is configured to receive an external device, wirelessly or directly connected and has a transceiver configured to scan for an unused channel and transmit audio. The speakers each have a mechanical connection on either side to connect to the center module or the other speakers. The two or more speakers are configured to scan the communication spectrum for the center module's unique identification and when the two or more speakers locate the center module's unique identification, the two or more speakers pair with the center module to receive audio. The communication spectrum can be a wireless channel such as 5.8GHz or the FM radio spectrum.



WO 2019/139932 A1

(84) Designated States (*unless otherwise indicated, for every kind of regional protection available*): ARIPO (BW, GH, GM, KE, LR, LS, MW, MZ, NA, RW, SD, SL, ST, SZ, TZ, UG, ZM, ZW), Eurasian (AM, AZ, BY, KG, KZ, RU, TJ, TM), European (AL, AT, BE, BG, CH, CY, CZ, DE, DK, EE, ES, FI, FR, GB, GR, HR, HU, IE, IS, IT, LT, LU, LV, MC, MK, MT, NL, NO, PL, PT, RO, RS, SE, SI, SK, SM, TR), OAPI (BF, BJ, CF, CG, CI, CM, GA, GN, GQ, GW, KM, ML, MR, NE, SN, TD, TG).

Published:

— *with international search report (Art. 21(3))*

Expandable Speaker System and Method for Broadcast

CROSS-REFERENCE TO RELATED APPLICATION

[0001] The present application claims the benefit of U.S. Provisional Patent Application No. 62/615,038 filed on January 9, 2018. The entire contents of this disclosure is hereby expressly incorporated by reference in its entirety.

FIELD OF INVENTION

[0002] The present disclosure is directed to an expandable wireless speaker system. More particularly, the present disclosure is directed to a speaker system and method of wirelessly communicating with at least one or more remote speakers to broadcast audio information from a connected device.

BACKGROUND

[0003] Audio systems include an audio source, such as a receiver, phone, computer, television, or other A/V device in communication with one or more speakers. The audio source may be communication with the speakers through a wired connection or by wireless communication means. Current systems and methods for wirelessly broadcasting and playing audio utilize Bluetooth or other wireless communication protocols. However, such wireless communication protocols do not allow for real-time audio listening and introduce a delay to be used with video to allow the sound to catch up. Additionally, current wireless systems may transmit audio from a device to a single receiver. This does not allow for surround sound or expandable systems.

SUMMARY OF THE INVENTION

[0004] In one embodiment, an expandable speaker system is described. The speaker system comprises a center module with a unique identification number, wherein the center

module is configured to communicate with an external audio device, wherein the center module has a first connector on a first side and a second connector on a second side, and at least two speakers in signal communication with the center module, the at least two speakers including a first speaker and a second speaker, wherein each of the at least two speakers has a volume control, wherein the first speaker includes a third connector configured to mechanically connect to the first connector, wherein the second speaker includes a fourth connector configured to mechanically connect to the second connector, wherein when the third connector is mechanically connected to the first connector and the fourth connector is mechanically connected to the second connector, the center module transmits a left stereo sound component to the first speaker and a right stereo sound component to the second speaker.

[0005] In another embodiment, a method for broadcasting audio through a speaker system, is described. The method comprises receiving signal communication from an external audio device at a center module and transmitting audio from the center module to at least two speakers, wherein when the at least two speakers are connected to the center module via a mechanical connection, each of the at least two or more speakers transmits a portion of audio dependent upon the location of the at least two or more speakers to the center module.

[0006] In yet another embodiment a speaker module is described. The speaker module comprises a power button, volume controls, a first connector, a second connector, a transceiver configured to scan a communication band for a device identification, and pairing the speaker module with the device to receive audio and an output module for broadcasting audio from the device.

BRIEF DESCRIPTION OF THE DRAWINGS

[0007] In the accompanying drawings, structures are illustrated that, together with the detailed description provided below, describe exemplary embodiments of the claimed invention. Like elements are identified with the same reference numerals. It should be

understood that elements shown as a single component may be replaced with multiple components, and elements shown as multiple components may be replaced with a single component. The drawings are not to scale and the proportion of certain elements may be exaggerated for the purpose of illustration.

[0008] **Figure 1** illustrates one embodiment of a speaker system with a center module and speakers attached;

[0009] **Figure 2** illustrates the speaker system with the center module and the speakers detached;

[0010] **Figure 3** illustrates a side view of the connections of the speakers;

[0011] **Figure 4** illustrates a cross-sectional view of the connections of the speaker system

[0012] **Figure 5** illustrates a rear view of a portion of the speaker system with the center module and the speakers detached;

[0013] **Figure 6** illustrates a flowchart for audio communication utilizing the proposed system;

[0014] **Figure 7** illustrates a stand-alone speaker.

DETAILED DESCRIPTION

[0015] The disclosure is described in the context of utilizing FM radio transmissions and wireless communication bands with one way communication.

[0016] **Figure 1** illustrates a perspective view of one embodiment of a speaker system **10**. The system **10** includes two main elements, a center module **100** and four expandable speakers **102a, 102b, 102c, 102d**.

[0017] The center module **100** and speakers **102a, 102b, 102c, 102d** are attached for transportation purposes. In one embodiment, the speakers **102a, 102b, 102c, 102d** and center module **100** are attached using a magnetic connection. In another embodiment, the speakers **102a, 102b, 102c, 102d** and center module **100** are attached using a snap mechanism. In yet

another embodiment, the speakers **102a**, **102b**, **102c**, **102d** and center module **100** are attached by sliding the speakers **102a**, **102b**, **102c**, **102d** and/or center module **100** utilizing an interlocking connection.

[0018] As the system **10** is intended to be expandable and remote, the center module **100** has its own power control button **104**, audio control button **106**, and volume control buttons **108**, and the speakers **102a**, **102b**, **102c**, **102d** each have their own power button **112** and volume controls **110** allowing each unit to have individual control of sound levels and power. In another embodiment, less than four speakers can be utilized in the system or additional speakers can be added to the ends of the existing speaker system **10**. In yet another embodiment, the center module **100** and speakers **102a**, **102b**, **102c**, **102d** are waterproof.

[0019] Turning to **Figures 2** and **3**, when the system **10** is in use, each of the speakers **102a**, **102b**, **102c**, **102d** can be disconnected from the center unit. As can be seen in this exploded view, the center module **100** and the speakers **102a**, **102b**, **102c** each include a connection **114**. In this embodiment, the end speaker **102d** does not include a connection. In alternative embodiments, each speaker includes a connection.

[0020] Where the connection is a snap connection or a magnetic connection, the speakers **102** are disconnected by applying sufficient force to overcome the magnetic or friction force of the connection. Where the connection is a sliding connection, the speakers **102** are disconnected by sliding or turning the speakers. The speakers may also be connected by a locking mechanism with a release mechanism (not shown in this view). After separation, the speakers **102a**, **102b**, **102c**, **102d** can be placed within 200 feet of the center module **100**, such as around a room, in preparation for use. When the system **10** is done being utilized, each speaker **102a**, **102b**, **102c**, **102d** may be reconnected to the center module **100** using the same connection **114** in preparation for storage or travel.

[0021] Each of the speakers **102a**, **102b**, **102c**, **102d** is capable of producing whole or partial sound, depending upon how the speaker **102a**, **102b**, **102c**, **102d** is utilized. When in use, if the speakers **102a**, **102b**, **102c**, **102d** are detached from the center module **100**, each speaker **102a**, **102b**, **102c**, **102d** produces whole audio. In another embodiment, when the speakers **102a**, **102b**, **102c**, **102d** are connected to the center module **100** and are in use, each speaker only produces a portion of audio. For example, a speaker **102a**, **102b**, **102c**, **102d** that is connected to the left of the center module **100** produces left stereo sound, while a speaker **102a**, **102b**, **102c**, **102d** that is connected to the right of the center module **100** will produce right stereo sound.

[0022] The connection **114** also serves to transfer power between the center module **100** and the speakers **102a**, **102b**, **102c**, **102d**. Each speaker includes an individual battery (not shown). To charge the batteries of the speakers in the system **10**, the center module **100** is plugged into a power source. While the center module **100** charges, power is also transferred to the attached speakers **102a**, **102b**, **102c**, **102d** through the connection **114** thus eliminating the need to charge the speakers **102a**, **102b**, **102c**, **102d** individually.

[0023] As illustrated in the cross-sectional view of the system **10** in **Figure 4**, the connections **114** both mechanically and electrically connect the speakers **102a**, **102b**, **102c**, **102d** to each other and to the center module **100**. The electrical connection allows for the transfer of power from the center module **100**.

[0024] In the illustrated embodiment, the center module **100** includes a male connector on the right side. A middle speaker **102a** has a female connector on its left side, configured to receive the male connector of the center module **100**. The middle speaker **102a** also includes a male connector on its right side. An end speaker **102b** includes a female connector on its left side, configured to receive the male connector of the middle speaker **102a**. In the illustrated embodiment, the end speaker only includes a single connector. In an alternative embodiment,

the end speaker may include an additional connector on a right side to allow connection to additional speakers.

[0025] While the illustrated embodiment does not show a connector on the left side of the center module **100**, it should be understood that in alternative embodiments, any type of connector may be employed on each side of the center module and speakers.

[0026] **Figure 5** illustrates a rear view of a portion of the speaker system **10**. In this view, a release button **506** is shown on the back of the speakers **102a**, **102b**. The center module **100** is configured to be in signal communication with an external audio device. Exemplary audio devices include, without limitation, radio receivers, phones, tablets, computers, phonographs, televisions, MP3 players, compact disk players, and cassette players. In one embodiment, an external device plugs into the center module **100** using a line in or other input **504**. In another embodiment, the center module **100** wirelessly communicates with the external audio device through a communication protocol such as Bluetooth. When an external device is connected to the center module **100**, the center module **100** communicates with the speakers **102a**, **102b**, **102c**, **102d** using RF communication. In one embodiment, the center module **100** communicates with the speakers **102a**, **102b**, **102c**, **102d** using FM radio waves resulting in very little delay or no delay. In another embodiment, the center module **100** communicates with the speakers **102a**, **102b**, **102c**, **102d** using a wireless connection band.

[0027] As illustrated by the flowchart of **Figure 6**, initializing the speaker system **10** occurs using the existing wireless band or FM radio spectrum. In one embodiment, the system **10** functions utilizing one-way communication from the center module **100** to the speakers **102a**, **102b**, **102c**, **102d**, eliminating the need for establishing a handshake or additional connections between the center module **100** and the speakers **102a**, **102b**, **102c**, **102d**. The center module **100** contains with a unique identification number. When the center unit is powered on **600**, the center module **100** initializes the wireless band and broadcasts its unique identification using

the wireless band. In one embodiment, the wireless band is a 5.8GHz wireless band. In an alternative embodiment, the system **10** functions utilizing two-way communication from the center module **100** to the speakers **102a**, **102b**, **102c**, **102d**, which may include a handshake or other pairing step. In such an embodiment, the two-way communication may occur over a 5.8GHz wireless band.

[0028] In one embodiment, when the center unit is powered on **600**, the center module **100** scans the FM radio spectrum for a clear and unused channel **602**. When an empty channel is found, the center module **100** broadcasts its unique identification on that channel using the Radio Data System (RDS) communications protocol **604**. If this is the first broadcast for the center module **100**, the center module **100** begins searching for a clear and empty channel starting with the lowest known FM radio channel. If this is not the first broadcast for the center module **100**, the center module **100** starts the scan of the FM radio spectrum at the last known channel it broadcasted on to determine if it is a clear and empty channel. If it is, the center module **100** will broadcast its unique identification. If the last known channel is no longer clear and empty, the center module **100** will begin searching the FM radio spectrum.

[0029] The speakers **102a**, **102b**, **102c**, **102d** are also powered on **606** and begin scanning searching for the center module's **100** unique identification **608** on either the wireless band or the FM radio spectrum. The speakers **102a**, **102b**, **102c**, **102d** may be powered on before the center module **100** is powered on. Alternatively, the speakers **102a**, **102b**, **102c**, **102d** may be powered on at the same time or after the center module **100** is powered on. Each speaker may be manually powered on individually, by pressing a power button **112**. Alternatively, the speakers **102a**, **102b**, **102c**, **102d** may be powered on by the center module **100**, such as through a wireless signal or through the connection **114**.

[0030] The speakers **102a**, **102b**, **102c**, **102d** are programmed to look for only the center module **100** unique identification. In one embodiment, the speakers connect to the wireless

band and search for the center module's **100** unique identification. In another embodiment, the speakers begin with the last known channel the center module **100** broadcasted on and searches for the center module's **100** unique identification. If the center module is not located on that channel, the speakers **102a**, **102b**, **102c**, **102d** begin scanning the FM radio spectrum. If this is the first time the speakers **102a**, **102b**, **102c**, **102d** have connected to the center module **100**, the speakers **102a**, **102b**, **102c**, **102d** begin scanning for the center module's **100** unique identification starting with the lowest known FM radio channel.

[0031] When the center module **100** and the speakers **102a**, **102b**, **102c**, **102d** are paired **610** the center unit can broadcast audio **612** from the external modules to the speakers **102a**, **102b**, **102c**, **102d** over the selected communication channel. The entire process connecting the center module **100** to the speakers **102a**, **102b**, **102c**, **102d** takes only a few seconds or fractions of a second.

[0032] In an alternative embodiment, where the center module **100** and the speakers **102a**, **102b**, **102c**, **102d** are in two-way communication over a 5.8GHz wireless band, the speakers and module may be paired together with a handshake or other communication protocol, and the step of scanning over a communication band may be omitted.

[0033] In one embodiment, additional speakers can be added to the ends of the existing system **10** using the same connection **114**. If additional speakers are added to the system **10**, the new speakers would need to be paired with the center module **100** to look for the center module's **100** unique identification. However, no handshake or additional connections are necessary. The present system **10** allows for multiple units in the same house without interference because each speaker is coded to only look for the paired center module **100**.

[0034] In another embodiment, if additional speakers (not shown) are added to the system **10**, the new speakers would simply be connected to the existing system **10**. Upon connection to the center module **100** or an existing speaker **102a**, **102b**, **102c**, **102d**, an electrical signal

would be passed between the speaker connections to the new speaker providing the new speaker with the center module **100** connection information. The speakers can then be removed as previously described and are ready to begin broadcasting audio.

[0035] **Figure 7** illustrates a single stand-alone speaker **700** that can be used without a connection to a center module **100**. The single stand-alone speaker **700** can be removed from the system **10** and placed within a 200ft radius around an existing audio module (not shown). The stand-alone speaker **700** still has its own power button **702** and volume controls **704** allowing the unit to have individual control of sound levels and power. When the system **10** is done being utilized, the stand-alone speaker **700** can be reconnected to a larger system with a center module **100** for charging in preparation for storage or travel or simply powered off in preparation for storage or travel.

[0036] The stand-alone speaker **700** functions utilizing one-way communication from an external audio device **706**. Exemplary audio devices include, without limitation, radio receivers, phones, tablets, computers, phonographs, televisions, MP3 players, compact disk players, and cassette players. In one embodiment, the external device plugs into the stand-alone speaker **700** using a line in or other input. In another embodiment, the stand-alone speaker **700** wirelessly communicates with the external audio device through a communication protocol such as Bluetooth. The stand-alone speaker **700** can be used as a single unit or can be used with multiple stand-alone speakers that each connect to the external audio device. When utilized as a stand-alone speaker **700**, without connecting to a center module **100**, the stand-alone speaker **700** produces whole audio sound.

[0037] In another embodiment, the system **10** can be utilized in a conference call environment. The system **10** would include the center module **100** and the four or more speakers **102a**, **102b**, **102c**, **102d** spaced around a room for conference calling. The center module **100** and speakers **102a**, **102b**, **102c**, **102d** would connect in the same manner as

previously described, however, the center module **100** and the speakers **102a**, **102b**, **102c**, **102d** would be set up for two way communication instead of simply one-way communication. Two-way communication allows the conference room attendees to talk during the call without having to move the microphone closer to the speaker. The system **10** would still function without requiring a handshake between the center module **100** and the speakers **102a**, **102b**, **102c**, **102d**.

[0038] The above merely illustrates the principles of the invention. It is thus appreciated that those skilled in the art will be able to devise various arrangements, which, although not explicitly described or shown herein, embody the principles of the invention and are included within its spirit and scope. Furthermore, all examples and conditional language recited herein are principally intended expressly to be only for pedagogical purposes to aid the reader in understanding the principles of the invention and the concepts contributed by the inventor(s) to furthering the art, and are to be construed as being without limitation to such specifically recited examples and conditions. Moreover, all statements herein reciting principles, aspects, and embodiments of the invention, as well as specific examples thereof, are intended to encompass both structural and functional equivalents thereof. Additionally, it is intended that such equivalents include both currently known equivalents as well as equivalents developed in the future, i.e., any elements developed that perform the same function, regardless of structure.

CLAIMS

What is claimed is:

1. An expandable speaker system, comprising:
 - a center module with a unique identification number,
 - wherein the center module is configured to communicate with an external audio device,
 - wherein the center module has a first connector on a first side and a second connector on a second side; and
 - at least two speakers in signal communication with the center module, the at least two speakers including a first speaker and a second speaker,
 - wherein each of the at least two speakers has a volume control,
 - wherein the first speaker includes a third connector configured to mechanically connect to the first connector,
 - wherein the second speaker includes a fourth connector configured to mechanically connect to the second connector,
 - wherein when the third connector is mechanically connected to the first connector and the fourth connector is mechanically connected to the second connector, the center module transmits a left stereo sound component to the first speaker and a right stereo sound component to the second speaker.
2. The expandable speaker system of claim 1, wherein the third connector is connected to the first connector by one of a magnetic connection, a snap-together connection, and a sliding interlock connection, and wherein the fourth connector is connected to the second connector by one of a magnetic connection, a snap-together connection, and a sliding interlock connection.

3. The expandable speaker system of claim 1, wherein the center module is configured to communicate with the external device through one of a line in connection and a wireless connection.
4. The expandable speaker system of claim 1, wherein the at least two speakers are configured to scan a communication band for the center module's unique identification, and wherein the at least two speakers are further configured to save the center module's unique identification and pair with the center module to receive audio.
5. The expandable speaker system of claim 1, wherein the center module and the at least two speakers are in two-way communication over a wireless band.
6. The expandable speaker system of claim 5, wherein the wireless band is a 5.8GHz wireless channel.
7. The expandable speaker system of claim 1, wherein the center module transceiver further comprises an FM transmitter configured to scan the FM radio spectrum for an unused FM radio station and transmit audio.
8. The expandable speaker system of claim 6, wherein a radio data system (RDS) of the unused FM radio station broadcasts the unique identification number of the center module to be received by the two or more speakers.
9. The expandable speaker system of claim 1, wherein when the third connector is disconnected from the first connector and the fourth connector is disconnected from the second connector, the center module transmits whole sound to the first speaker and whole sound to the second speaker.
10. A method for broadcasting audio through a speaker system, comprising:

receiving signal communication from an external audio device at a center module; and

transmitting audio from the center module to at least two speakers,

wherein when the at least two speakers are connected to the center module via a mechanical connection, each of the at least two or more speakers transmits a portion of audio dependent upon the location of the at least two or more speakers to the center module.

11. The method for broadcasting audio through a speaker system of claim 10, wherein when the at least two speakers are disconnected from the center module, the at least two speakers producing whole audio.

12. The method for broadcasting audio through a speaker system of claim 10, wherein the first connector and second connector are one of a magnetic connection or a snap-together connection or a sliding interlock connection.

13. The method for broadcasting audio through a speaker system of claim 10, further including:

scanning for a clear and unused channel using a transceiver of the center module;

transmitting a unique identifier of the center module on the clear and unused channel;

scanning for the unique identifier of the center module using a receiver of the at least two or more speakers, wherein when the unique identifier is located, saving the center module's unique identifier to the at least two or more speakers and pairing the center module and the least two or more speakers.

14. The method for broadcasting audio through a speaker system of claim 10, further comprising pairing the center module and the at least two speakers over a wireless band.

15. The method for broadcasting audio through a speaker system of claim 14, wherein the wireless band is a 5.8GHz wireless band.

16. The method for broadcasting audio through a speaker system of claim 13, wherein the transceiver of the center module further comprises an FM transmitter configured to scan the FM radio spectrum for an unused FM radio station and transmit audio.

17. The method for broadcasting audio through a speaker system of claim 16, wherein a radio data system (RDS) of the unused FM radio station broadcasts the unique identification number of the center module to be received by the two or more speakers.

18. A speaker module, comprising:

a power button;

volume controls;

a first connector;

a second connector;

a transceiver configured to scan a communication band for a device identification, and pairing the speaker module with the device to receive audio; and

an output module for broadcasting audio from the device.

19. The speaker of claim 18, wherein the transceiver is configured to scan for unique identification number of a center module.

The speaker of claim 18, wherein the transceiver is configured to scan for an external device, wherein the external device broadcasts audio.

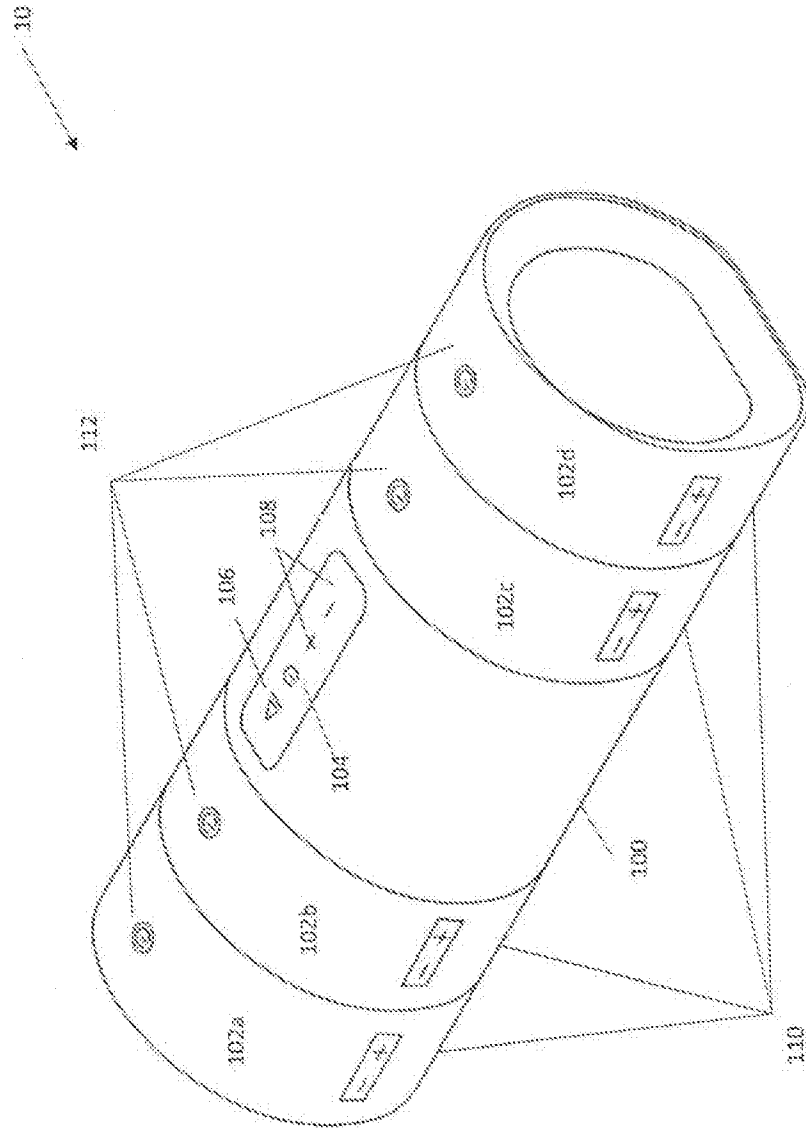

Figure 1

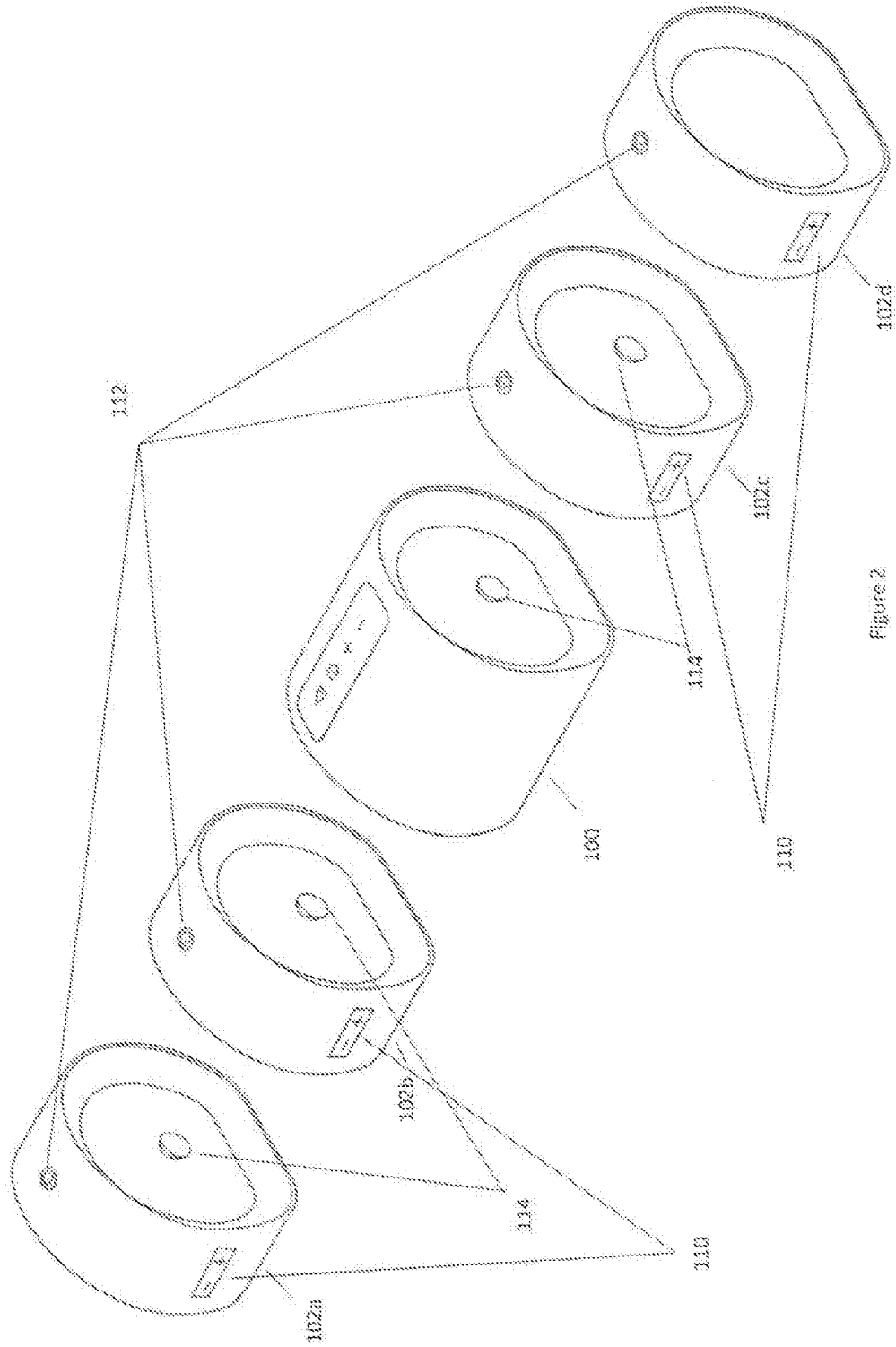

Figure 2

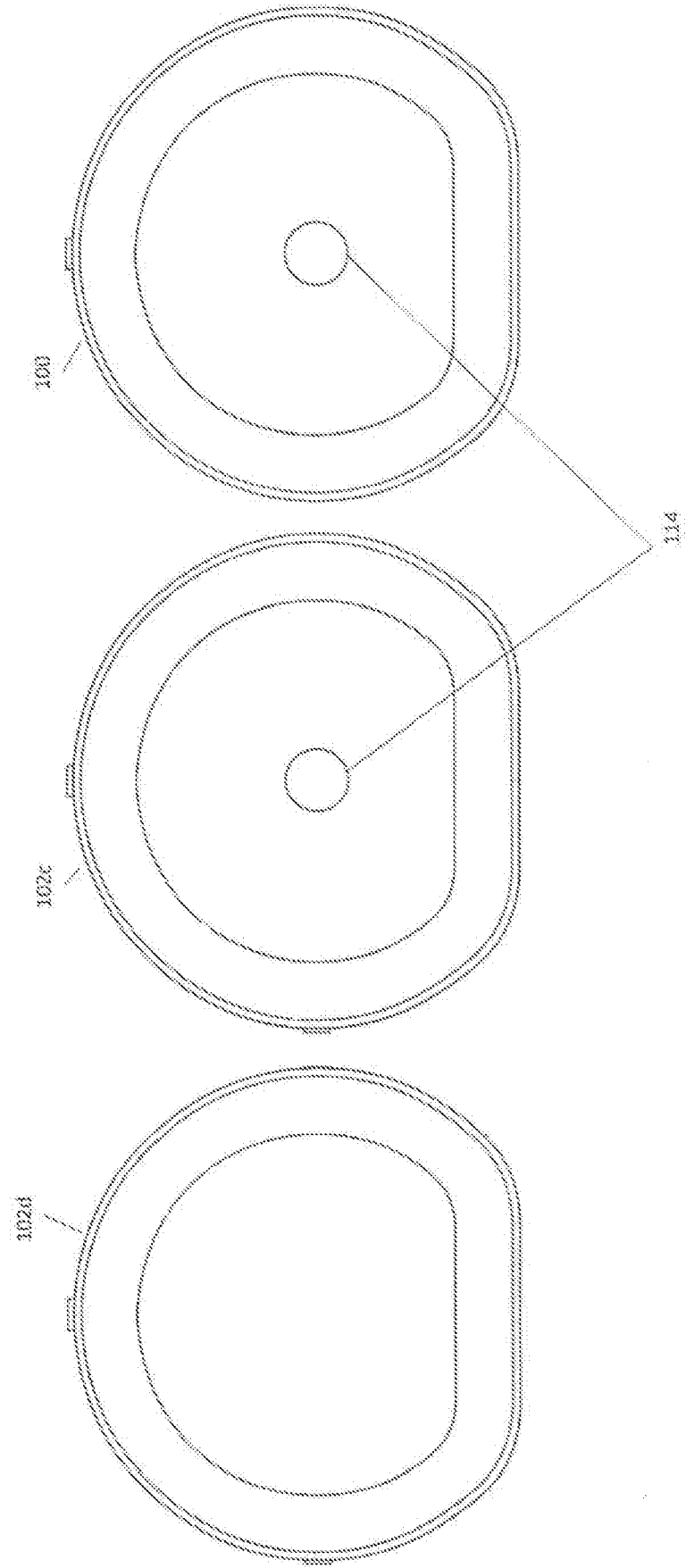

Figure 3

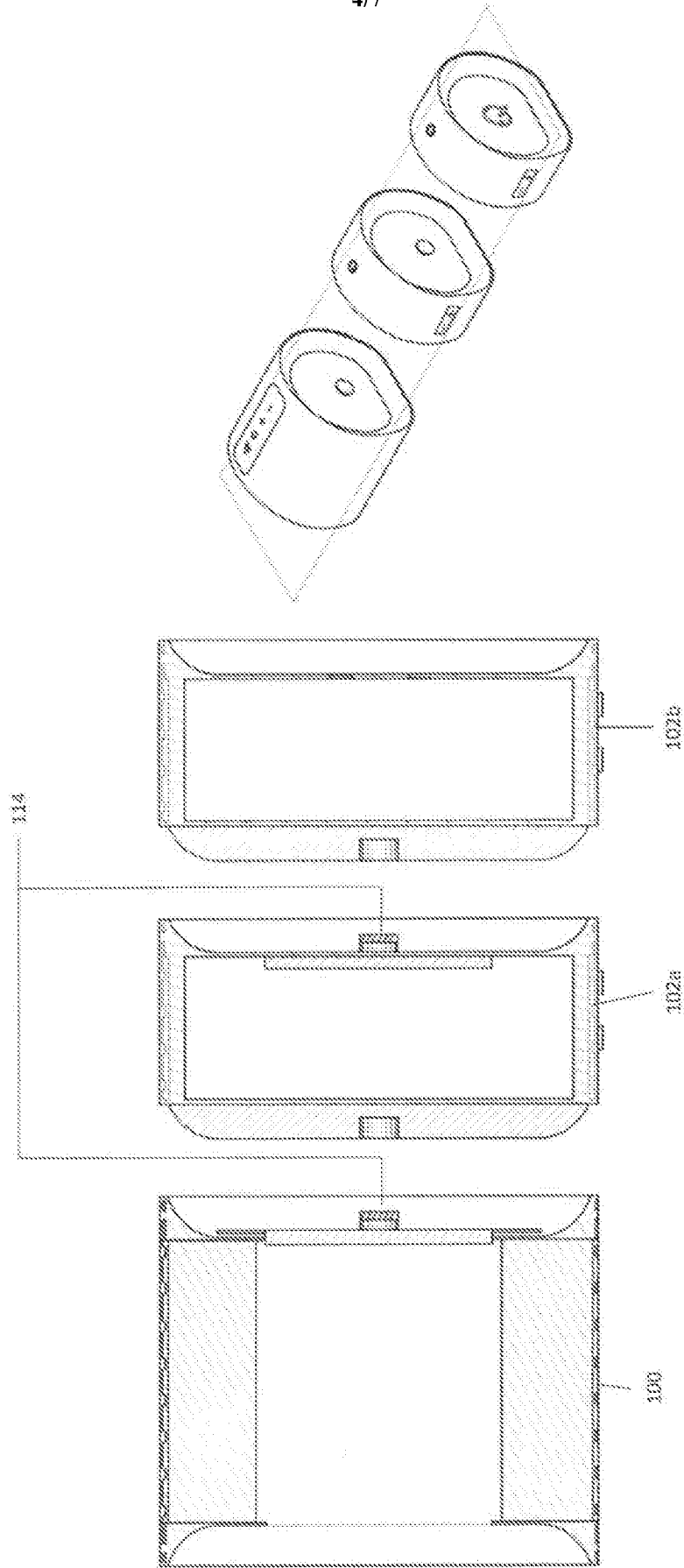

Figure 4

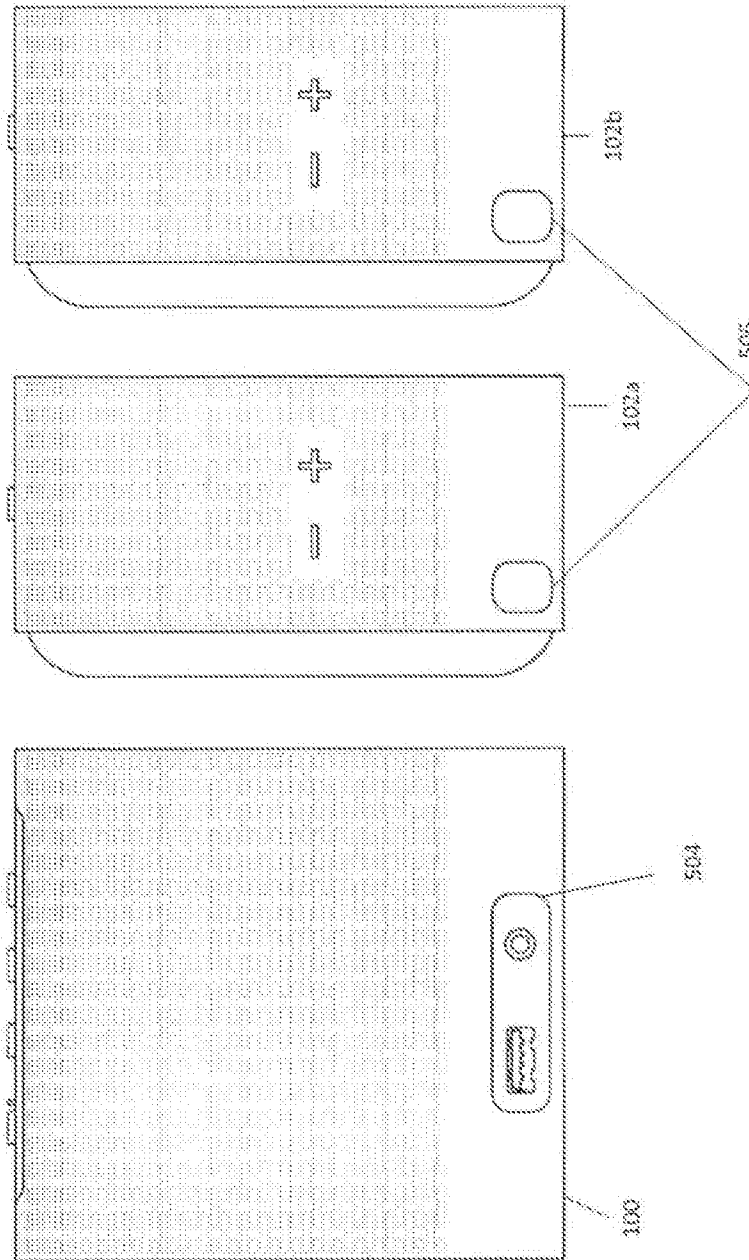

Figure 5

6/7

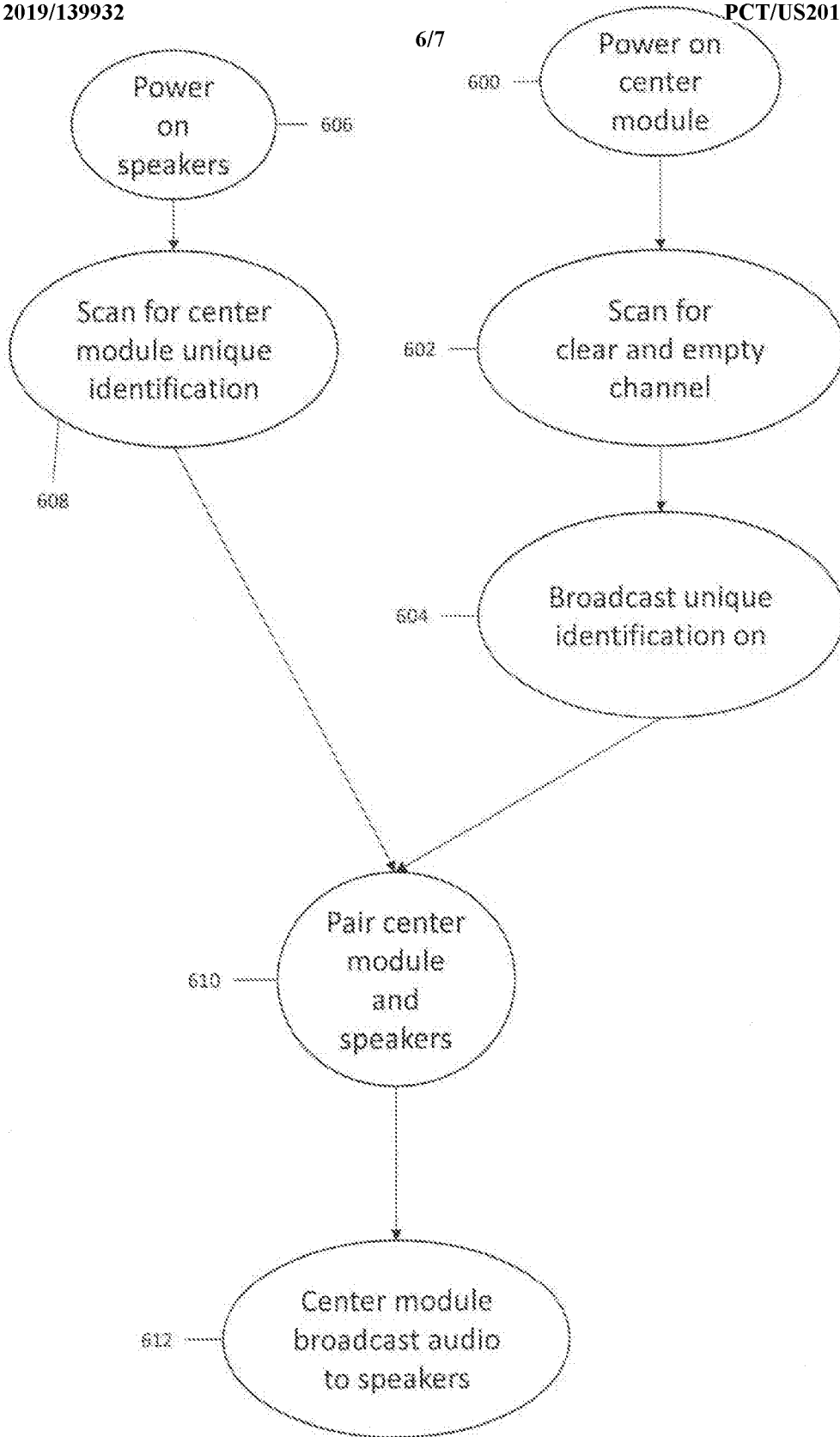

Figure 6

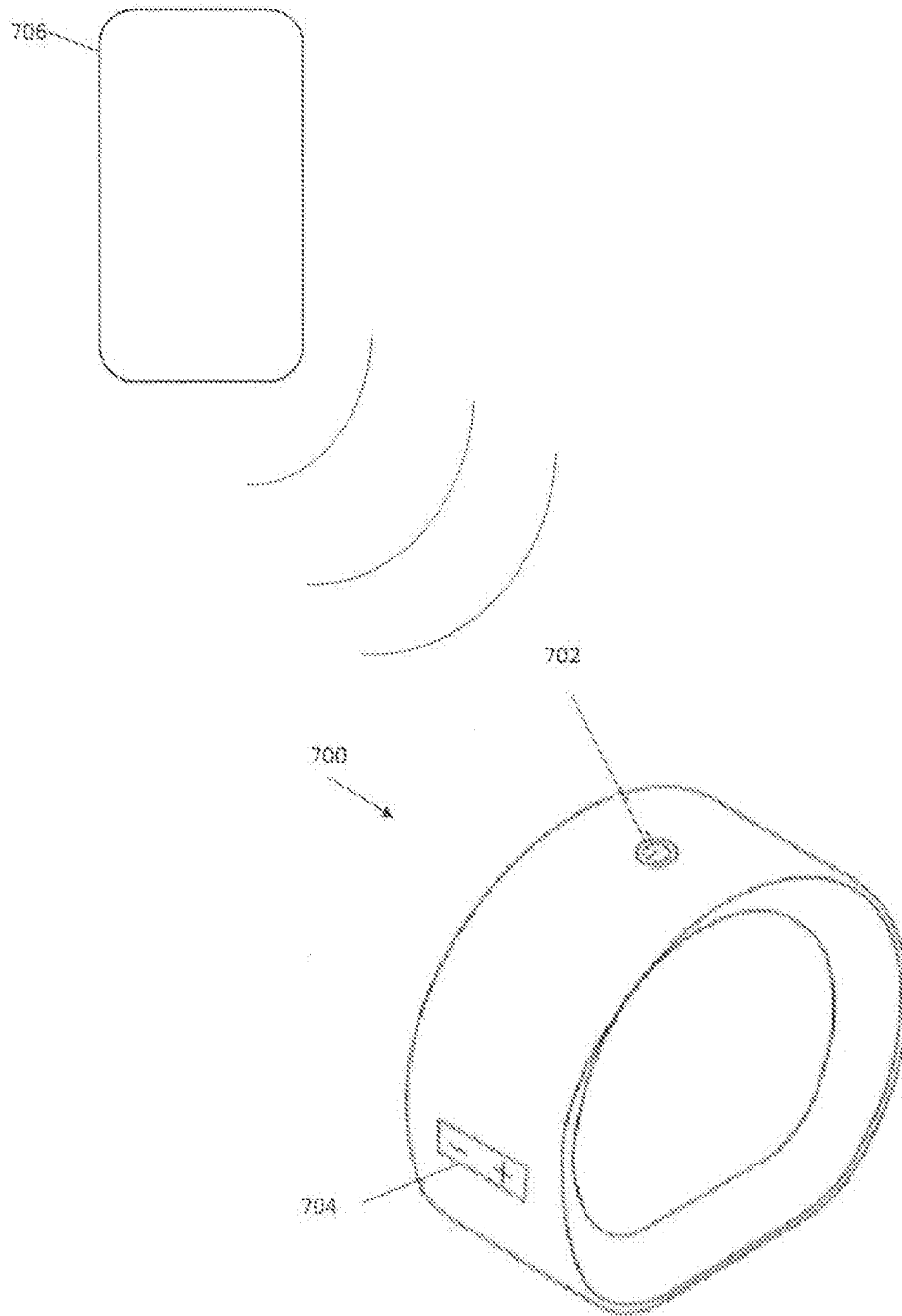

Figure 7

INTERNATIONAL SEARCH REPORT

International application No.
PCT/US2019/012816**A. CLASSIFICATION OF SUBJECT MATTER****H04R 1/02(2006.01)i**

According to International Patent Classification (IPC) or to both national classification and IPC

B. FIELDS SEARCHEDMinimum documentation searched (classification system followed by classification symbols)
H04R 1/02; G10L 19/04; H04R 1/00; H04R 1/28; H04R 15/00; H04R 3/12Documentation searched other than minimum documentation to the extent that such documents are included in the fields searched
Korean utility models and applications for utility models
Japanese utility models and applications for utility modelsElectronic data base consulted during the international search (name of data base and, where practicable, search terms used)
eKOMPASS(KIPO internal) & Keywords: speaker, wireless, bluetooth, broadcast, expand, extend, module, identification, number**C. DOCUMENTS CONSIDERED TO BE RELEVANT**

Category*	Citation of document, with indication, where appropriate, of the relevant passages	Relevant to claim No.
Y A	US 2015-0287419 A1 (ISSC TECHNOLOGIES CORP.) 08 October 2015 See paragraphs [0024]-[0041] and figures 1-5.	1-6, 9-12, 14-15 , 18-20 7-8, 13, 16-17
Y	US 2011-0286613 A1 (BARRY J. LIPSKY et al.) 24 November 2011 See paragraph [0015] and figures 1-3.	1-6, 9-12, 14-15
Y	US 2016-0150320 A1 (AVNERA CORPORATION) 26 May 2016 See paragraphs [0017]-[0028], claim 14 and figures 1-6.	1-6, 9, 18-20
A	US 2015-0049895 A1 (DESIGNPOINT INDUSTRIAL DESIGN STUDIO, INC.) 19 February 2015 See paragraphs [0053]-[0082] and figures 1A-3K.	1-20
A	KR 10-1641510 B1 (BEOM KYU CHOO) 21 July 2016 See paragraphs [0034]-[0044] and figures 2-7. (*Note: The claim without its claim number after claim 19 has been numbered 20.)	1-20

 Further documents are listed in the continuation of Box C. See patent family annex.

* Special categories of cited documents:

"A" document defining the general state of the art which is not considered to be of particular relevance

"E" earlier application or patent but published on or after the international filing date

"L" document which may throw doubts on priority claim(s) or which is cited to establish the publication date of another citation or other special reason (as specified)

"O" document referring to an oral disclosure, use, exhibition or other means

"P" document published prior to the international filing date but later than the priority date claimed

"T" later document published after the international filing date or priority date and not in conflict with the application but cited to understand the principle or theory underlying the invention

"X" document of particular relevance; the claimed invention cannot be considered novel or cannot be considered to involve an inventive step when the document is taken alone

"Y" document of particular relevance; the claimed invention cannot be considered to involve an inventive step when the document is combined with one or more other such documents, such combination being obvious to a person skilled in the art

"&" document member of the same patent family

Date of the actual completion of the international search

30 April 2019 (30.04.2019)

Date of mailing of the international search report

30 April 2019 (30.04.2019)

Name and mailing address of the ISA/KR

International Application Division
Korean Intellectual Property Office
189 Cheongsa-ro, Seo-gu, Daejeon, 35208, Republic of Korea

Facsimile No. +82-42-481-8578

Authorized officer

KANG, Min Jeong

Telephone No. +82-42-481-8131



INTERNATIONAL SEARCH REPORT

Information on patent family members

International application No.

PCT/US2019/012816

Patent document cited in search report	Publication date	Patent family member(s)	Publication date
US 2015-0287419 A1	08/10/2015	CN 104980843 A TW 201540086 A TW I599240 B	14/10/2015 16/10/2015 11/09/2017
US 2011-0286613 A1	24/11/2011	US 8311254 B2 US D643020 S1	13/11/2012 09/08/2011
US 2016-0150320 A1	26/05/2016	CN 107534812 A EP 3222063 A1 JP 2018-504801 A KR 10-2017-0089891 A TW 201633801 A US 10142734 B2 US 2017-0085989 A1 US 2017-0272861 A1 US 2018-0295445 A1 US 9544690 B2 US 9699560 B2 US 9998827 B2 WO 2016-081945 A1	02/01/2018 27/09/2017 15/02/2018 04/08/2017 16/09/2016 27/11/2018 23/03/2017 21/09/2017 11/10/2018 10/01/2017 04/07/2017 12/06/2018 26/05/2016
US 2015-0049895 A1	19/02/2015	US 9351066 B2 WO 2015-026618 A1	24/05/2016 26/02/2015
KR 10-1641510 B1	21/07/2016	None	