

(No Model.)

3 Sheets—Sheet 1.

# H. WEEKS & E. WOODWARD.

## NAILING MACHINE.

No. 335,261.

Patented Feb. 2, 1886.

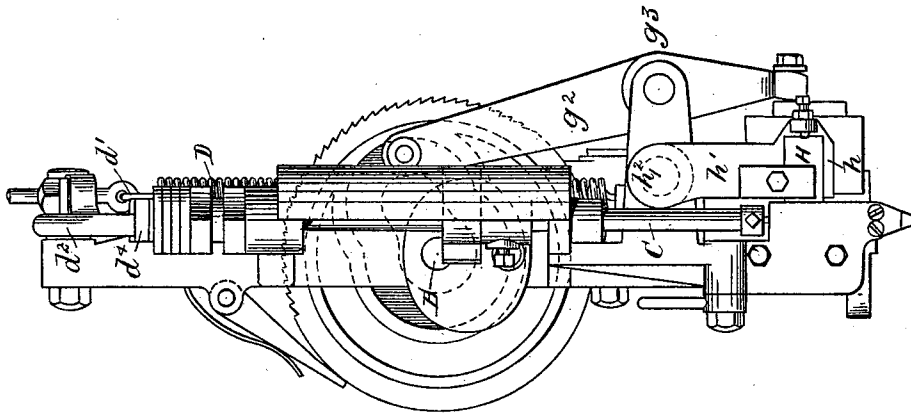

FIG. 2-

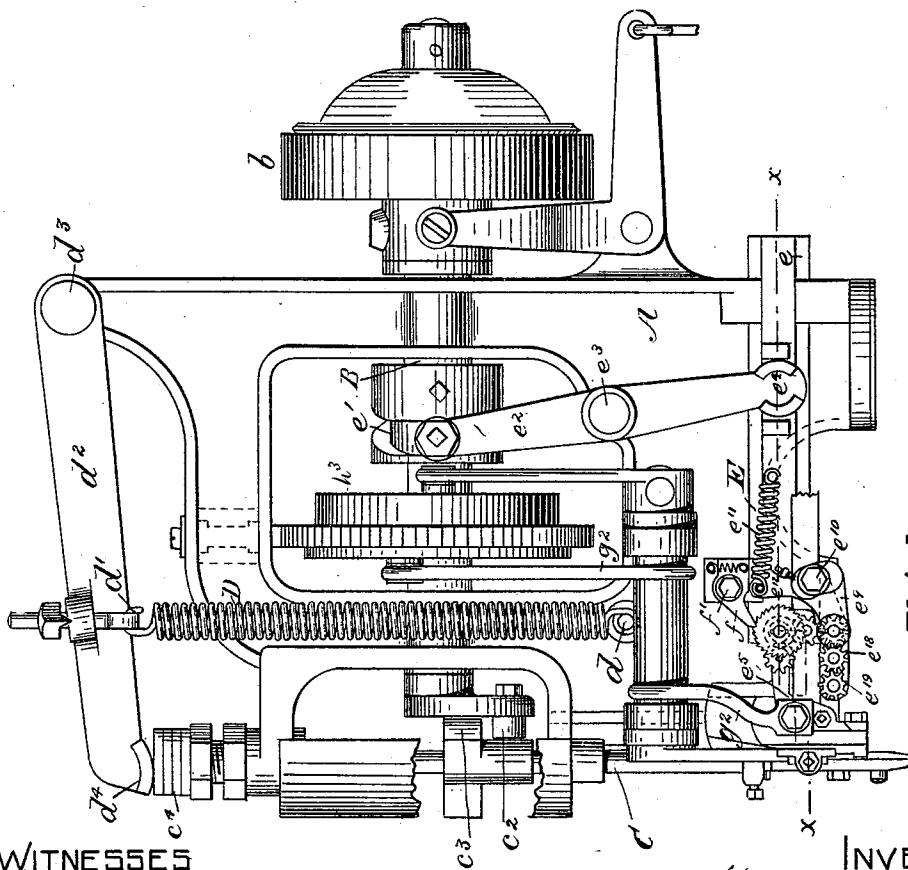

FIG. 1-

WITNESSES

*Wm. B. Dolan*  
*J. B. Gardner*

INVENTOR

*Frank Weeks*  
*Ernest Woodward*  
by *Wm. A. Clark & Raymond*

H. WEEKS & E. WOODWARD.  
NAILING MACHINE.

No. 335,261.

Patented Feb. 2, 1886.

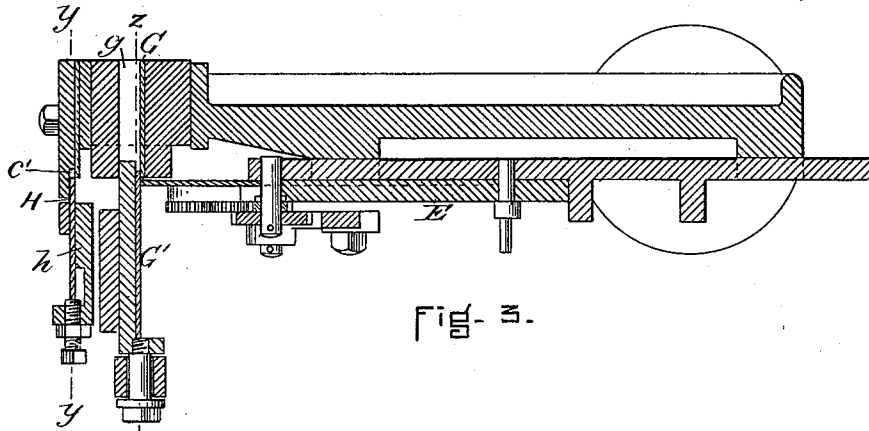

FIG-3-

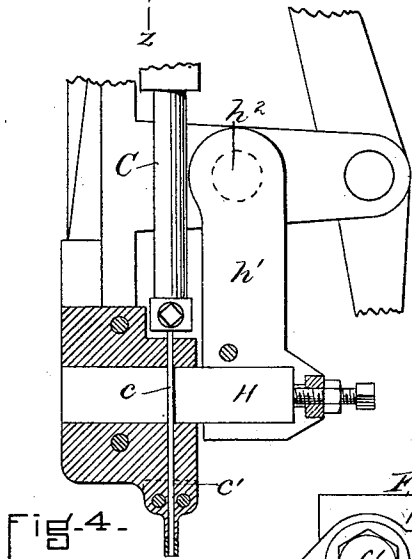

FIG-4-

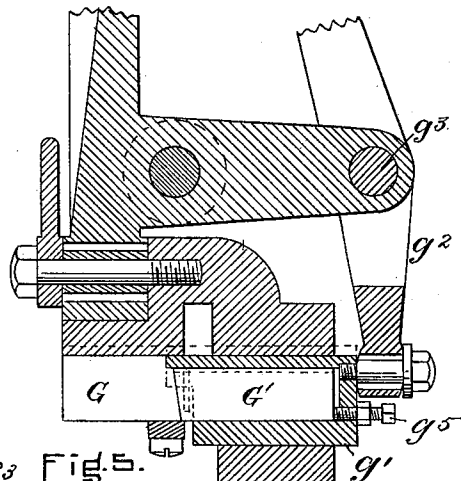

FIG-5-

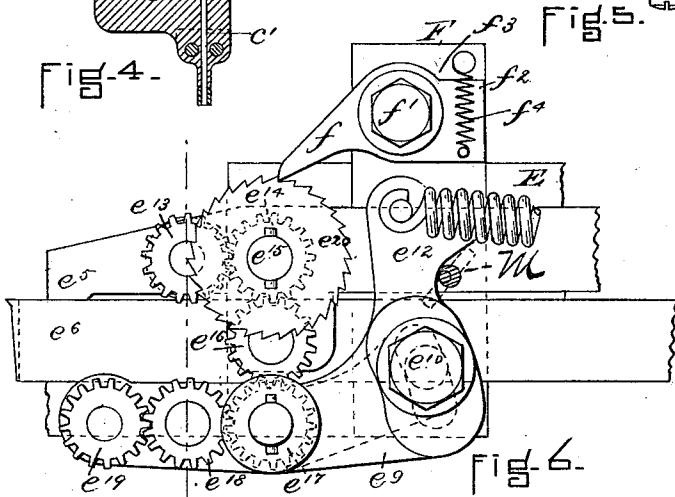

FIG-6-

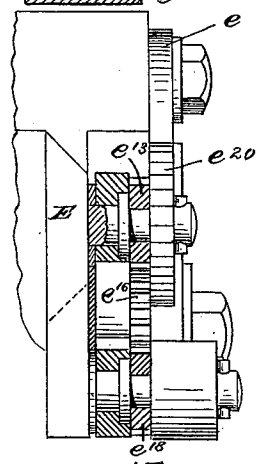

FIG-7-

WITNESSES

*Fred. B. Dolan.*  
*J. B. Gardner*

INVENTOR

*Horace Weeks*  
*Erastus Woodward*  
by their attys. *Clarke & Raymond*

H. WEEKS & E. WOODWARD.  
NAILING MACHINE.

No. 335,261.

Patented Feb. 2, 1886.

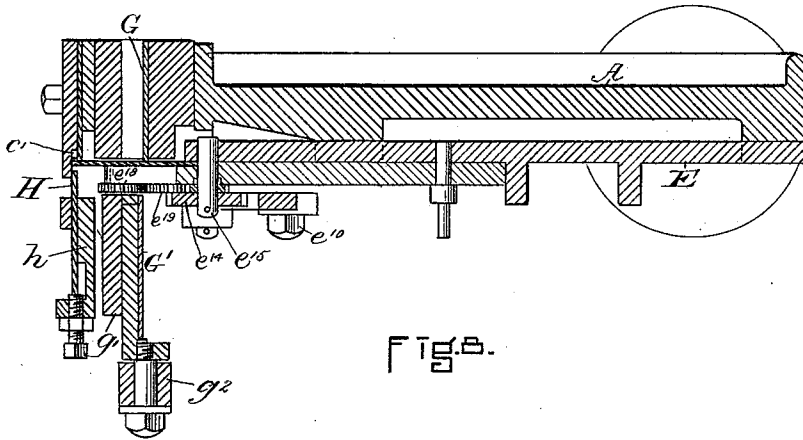

FIG. 8.

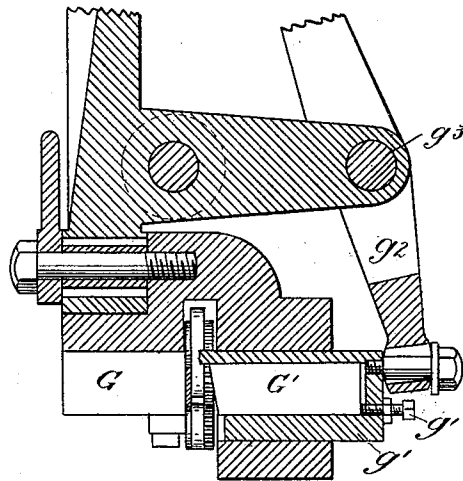

FIG. 9.

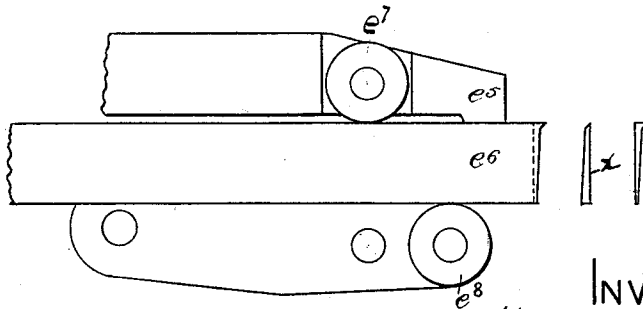

FIG. 10.

WITNESSES  
*Wm. B. Dolan*  
*J. A. Gardner*

INVENTOR  
*H. Weeks & E. Woodward*  
 by their attys. *Clarke & Raymond*

# UNITED STATES PATENT OFFICE.

HORACE WEEKS, OF BOSTON, AND ERASTUS WOODWARD, OF SOMERVILLE,  
MASSACHUSETTS; SAID WOODWARD ASSIGNOR TO SAID WEEKS.

## NAILING-MACHINE.

SPECIFICATION forming part of Letters Patent No. 335,261, dated February 2, 1886.

Application filed September 22, 1885. Serial No. 177,807. (No model.)

*To all whom it may concern:*

Be it known that we, HORACE WEEKS, of Boston, in the county of Suffolk and State of Massachusetts, and ERASTUS WOODWARD, of Somerville, in the county of Middlesex, in said State, both citizens of the United States, have invented a new and useful Improvement in Nailing-Machines, of which the following is a full, clear, and exact description.

10 The object of the invention is to provide means for forming from a thin metal plate a nail of peculiar shape, and also for feeding the nail thus formed into a position to be driven, and for driving the same.

15 In the drawings, Figure 1 represents a side elevation of the machine, a portion of the front of the frame being broken out to show the devices for lifting the driver-bar. Fig. 2 is a front elevation of the machine. Fig. 3 is a view in horizontal section enlarged upon the line  $xx$  of Fig. 1. Fig. 4 is a view in vertical section upon the line  $yy$  of Fig. 3. Fig. 5 is a vertical section upon the line  $zz$  of Fig. 3. Fig. 6 is a view in elevation of a portion of the nail strip or plate feeding mechanism hereinafter described. Fig. 7 is a vertical section upon the line  $xx$  of Fig. 6. Figs. 8, 9, and 10 are detail views.

20 In order to understand the construction and operation of this machine, it is necessary to provide a short description of the nail plate or strip used therewith and of the nail made therefrom.

25 In Fig. 10, I have represented in elevation the nail plate or strip, and it will be seen that it is a thin plate of one thickness throughout and having parallel edges, the plate being of the width of the nail to be made, and the nail made from this strip or plate is formed or cut from the end of the plate, so that the head thereof shall be provided from the length of the strip. This is accomplished by cutting out from the strip a section between the shanks, (see  $x$ , Fig. 10,) and the shape of this section and this process of making nails I have made the subject-matter of a separate application.

30 The shape of the nail which I prefer to use is well represented in Fig. 10—that is, it has a straight side, a tapering side, and a head formed to project from one edge thereof. I prefer that the point be very nearly sharp; but, so far as

the mechanism herein described is concerned, I do not limit myself to the especial form or shape of the nail, as it is adapted by varying the cutters and dies to cut from the strip or plate nails of any shape. 55

Referring to the drawings, A represents the frame of the machine.

B is the main shaft, which is supported by the frame, and carries the driver-pulley  $b$  at its outer end. 60

C is the driver bar or rod. It supports at its lower end the driver  $c$ , which is reciprocated in the driver-way passage or throat  $c'$  upon the movement of the driver bar or rod. The driver-bar is lifted by means of the crank-pin  $c^2$  at the front end of the shaft B, which engages under the surface of the disk or plate  $c^3$ , and which is fastened to the driver rod or bar and lifts the same while it is in contact therewith. This plate or disk is so shaped, however, that after the rod or bar has been lifted a sufficient distance it is released from the crank-pin by its movement in relation thereto, and when so released the driver-rod is pulled or moved forcibly downward by the spring D, which is fastened at  $d$  to the frame and at  $d'$  to the lever  $d^2$ , the end  $d^3$  of which is pivoted to the frame, and the end  $d^4$  rests upon the upper surface,  $c^4$ , of the driver rod or bar. 75

We prefer to form the edge or section of the lever which is brought in contact with the upper end of the driver bar or rod rounded, as represented in Fig. 1. 85

In this machine I employ two cutters or devices for forming the nail and severing it from the strip. The cutter which first operates is adapted to sever from the end of the strip the piece or waste, the removal of which forms the head and the taper or bevel of the nail; and after the strip has thus been acted upon by this cutter it is moved forward to the action of the second cutter, which completes the nail by severing the partially-formed end of the strip, and at the same time it moves or advances the nail into the throat or driver-way beneath the driver. 95

It will be seen that upon the insertion of the strip or plate in the machine the strip is placed in the strip-holder, so that its end shall be brought opposite the end of the first cut- 100

ter, and the first operation of this cutter removes or cuts off the waste from the end of the strip. The strip-holder and strip are then moved forward until the end of the strip comes in contact with the wall of the lateral passage in the throat. The second cutter is then reciprocated to sever the complete nail from the end of the strip and to advance it to the throat of the machine. The strip-holder and strip are then moved backward to the first cutter, but while they are being moved backward the strip-feeding mechanism is operated to advance the strip in the holder a distance equal to the width of a severed nail, and the machine continues to operate in this manner. To accomplish this, I use a feed carriage or block, E, which has a passage or way, *e*, of suitable shape, to hold the strip in a vertical position. This feed carriage or block is reciprocated at proper intervals by means of the cam *e'* on the shaft B, the lever *e''*, which is pivoted at *e'''*, and the lower end, *e''''*, of which lays hold of the feed carriage or block. The feed carriage or block also has a nail strip or plate clamping device or holder, which is adapted to clamp or hold the strip or plate preferably by its lower and upper edges. This clamping device comprises the bearing lug or projection *e''''''*, the under surface of which forms the bearing-shoulder *e''''''''*, and projects into the feedway *e*. Behind this shoulder or bearing-surface is a feed-roll, *e''''''''''*, which is supported by the feed carriage or block E, and preferably has a roughened or serrated surface and bears upon the upper edge of the strip. The lower edge of the strip rests upon the feed-roll *e''''''''''*, which is also carried by the reciprocating carriage or block E, and it is placed, preferably, midway between the bearing-surface *e''''''''''* and the roll *e''''''''''*, so that the strip shall be held firmly clamped in the carrier or block.

The roll *e''''''''''*, instead of being directly secured to the block E, is mounted upon a lever or yielding support, *e''''''''''''*, which is pivoted at *e''''''''''''''* to the reciprocating carrier or block E, and the spring *e''''''''''''''''*, attached at one end to the end *e''''''''''''''''* of the lever *e''''''''''''''* and at the other end to the carrier-block, serves to hold the feed-roll in contact with the lower edge of the strip.

We have now described the nail strip or plate holding device and the means for providing it with a reciprocating movement. It is essential, however, that the nail plate or strip have a forward movement, which reciprocation of the block or carrier should be equal at least to the width of the severed portion of the strip; and to provide the strip with such movement I have arranged upon the shaft of the roll *e''''''''''* the gear *e''''''''''''*, which is engaged by the gear *e''''''''''''''* upon the ratchet-shaft *e''''''''''''''''*. This gear *e''''''''''''''* also engages the gear *e''''''''''''''''*, which in turn engages the gear *e''''''''''''''''''*, mounted upon the lever *e''''''''''''''*, and the gear *e''''''''''''''''''* meshes with the gear *e''''''''''''''''''''*, which in turn engages the gear *e''''''''''''''''''''''* on the shaft of the lower feed-roll, *e''''''''''*. It will thus be seen that the feed-rolls are geared to move the nail plate or strip formed upon the

backward movement of the carrier. This feeding movement must take place, of course, after the nail has been formed and driven; and I accomplish this by mounting on the stationary post F a stationary detent or pawl, *f*, which is pivoted at *f'* to the post. It is provided with a shoulder *f''*, which comes in contact with the shoulder *f''''* of the post to limit the extent of its downward movement, and the spring *f''''''*, attached to the pawl and the post, serves to return the pawl or detent to normal position. The detent or pawl is so hung that its lower end is in line with the movement of the ratchet-wheel *e''''''''*, and as this wheel is reciprocated with the carrier it follows that upon its backward movement a tooth must come in contact with the end of the pawl or detent, and by the movement of the carrier or block E cause the ratchet-wheel shaft *e''''''''''* to be revolved a portion of a revolution, and this of course communicates movement to the feed-rolls and causes them to move the strip formed in the carrier. The cutting devices for removing the waste from the end of the strip and partially forming the nail comprise the stationary cutter G and the reciprocating cutter G'. The cutter G has its surface flush with the vertical surface of the feedway, and the cutter G' is reciprocated in a suitable passage across the feedway and past the end of the cutter G. This movement severs the waste and carries it from the feedway to the escape channel or passage *g*. The cutter G' is held by the block *g'*, which is reciprocated in suitable bearings or supports in the frame of the machine by means of the lever *g''*, pivoted at *g''''*, and the cam *g''''''* on the main shaft B. The cutter G' is adjusted in its block *g'* by means of the screw *g''''''''*. The relation which the cutters G and G' bear to the feedway or passage is well shown in Fig. 5. The cutter G is fastened in place in any desirable way.

The cutting device for severing the partially formed nail from the end of the strip comprises the cutter H, which is reciprocated at the end of the feedway across the same to the throat or driver passage. It is carried or supported by a suitable block, *h*, and is reciprocated by means of the lever *h'*, pivoted at *h''*, and the cam *h''''*. This cutter H has a straight cutting surface or edge, and it not only serves to sever the nail from the end of the nail plate or strip, but it also carries it into the throat or driveway of the machine beneath the driver, and it then remains stationary during the reciprocation of the driver in driving the nail, so that its cutting-surface forms for the time being a part of one of the walls of the throat or driver-passage.

We prefer that the time of the machine be substantially as follows: Upon the starting of the machine the waste is first severed from the end of the strip. It is then moved forward until its front end comes in contact with the wall across the end of the feed-passage. The cutter H is then immediately caused to sever the nail upon the end of the strip and carry it

to the driver, and it remains stationary until the nail has been driven. Meanwhile the feed carrier or plate has been returned to its original position and the nail strip or plate fed forward thereon to bring its front edge into position to be again operated upon by the first cutter.

In order that the nail strip or plate may be easily placed or removed in the feeding device, we have provided the eccentric post M, which is attached to the frame, so as to be turned to move its eccentric surface against the upper arm,  $e^{12}$ , of the lever  $e^9$ , and it will be seen that by turning this stud to bring this surface in contact therewith the portion of the lever carrying the feed-roll is moved downward and held locked in that position, and that upon the turning of the stud to withdraw the eccentric surface the spring  $e^{11}$  automatically returns the lever and feed-roll to their normal position.

We do not confine ourselves to the specific devices herein described for operating the feed-rolls and cutters, but may use any mechanical equivalent therefor.

We are aware that Patent No. 169,463 to McKay and Fairfield describes a nail-plate-feeding device comprising two feed-pawls, which are reciprocated to advance the strip in a stationary holder to a cutting device, the strip being moved by the pawls in one direction only, and we do not claim this method of feeding a nail-strip.

Having thus fully described our invention, we claim and desire to secure by Letters Patent of the United States—

1. The combination, in a nailing-machine, of a nail-driver, a reciprocating nail-strip-feed carriage or block carrying a strip-clamping device, and reciprocating nail cutting or severing devices for cutting nails in successive order from the end of the strip, all substantially as and for the purposes described.

2. The combination, in a nail-machine, of the reciprocating driver and the horizontally-reciprocating nail plate or strip feed carriage or block carrying strip clamping and feeding devices, all substantially as and for the purposes described.

3. The combination, in a nailing machine, of nail-driving devices, a reciprocating nail plate or strip feed carriage or block carrying strip clamping and feeding devices, and two cutters or nail-forming devices, the first of which partially shapes the nails and the second of which completes the nail by severing it from the strip, all substantially as and for the purposes described.

4. The combination, in a nailing machine, of the nail-driver, two nail cutting or forming devices, a reciprocating nail plate or strip feed carriage or block carrying strip-clamping devices adapted to advance the nail plate or

strip from one cutter to the other, and the nail plate or strip feeding device adapted to automatically advance the plate or strip in the holder a distance equivalent to the width of the nail severed therefrom, all substantially as and for the purposes described.

5. In a nailing-machine, a reciprocating nail strip or plate holding device, comprising the abutment  $e^5$ , roll  $e^7$ , and the supporting-roll  $e^8$ , arranged in relation to each other as described, all substantially as and for the purposes set forth.

6. In a nailing-machine, the nail plate or strip holding and feeding device, comprising a reciprocating block having the abutment  $e^5$ , and supporting the feed-rolls  $e^7$ ,  $e^8$ , the ratchet-wheel  $e^{10}$ , connected with the feed-rolls, and the pawl or detent  $f$ , all substantially as described.

7. The combination of the abutment or projection  $e^5$ , having the surface  $e^6$ , the roll  $e^7$ , and the movable roll  $e^8$ , all substantially as described.

8. The combination of the reciprocating block having a feedway and the abutment or projection  $e^5$ , having the surface  $e^6$ , the roll  $e^7$ , and the roll  $e^8$ , supported by the yielding lever  $e^9$ , all substantially as described.

9. The combination of the block having the abutment or projection  $e^5$ , having the surface or shoulder  $e^6$ , the roll  $e^7$ , with the roll  $e^8$ , and means for moving it vertically and locking or holding it so removed, all substantially as described.

10. The combination, in a nailing-machine, of a reciprocating nail-driver and the two reciprocating cutters or severing devices arranged in relation to each other, as specified, mechanism for operating the same, and suitable strip-feeding devices, whereby in operation one of the cutters is reciprocated across the line of the feed to partially form the nail upon the nail plate or strip, the nail plate or strip fed, and the second cutter reciprocated across the end of the feedway to complete the nail by severing it from the plate or strip, and to carry it from the feedway to the driver, all substantially as described.

11. The combination, in a nailing-machine, of a nail-driver, its throat having a lateral opening at right angle to the line of the feed of the nail strip or plate, and a reciprocating cutter, and mechanism for operating the same, whereby it is caused to be moved across the line of the feed into the lateral opening of the throat and to form one of the walls of the throat while the nail is being driven, all substantially as and for the purposes described.

HORACE WEEKS.  
ERASTUS WOODWARD.

Witnesses:

FRED. B. DOLAN,  
J. B. GARDNER.