

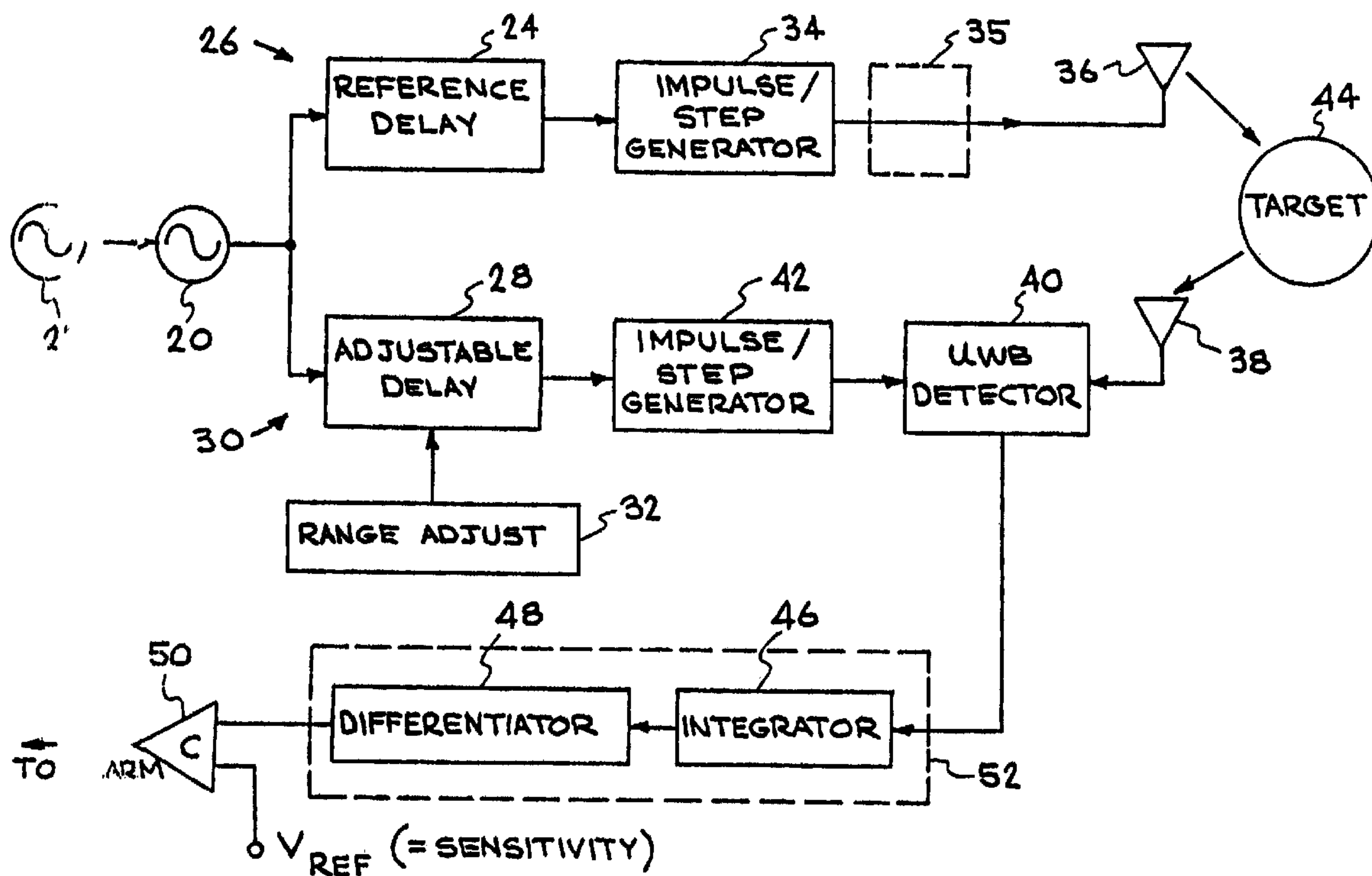

(22) Date de dépôt/Filing Date: 1994/04/08
 (41) Mise à la disp. pub./Open to Public Insp.: 1994/10/27
 (45) Date de délivrance/Issue Date: 2008/08/05
 (62) Demande originale/Original Application: 2 160 352
 (30) Priorité/Priority: 1993/04/12 (US08/044,717)

(51) Cl.Int./Int.Cl. *G01S 13/522* (2006.01),
G01S 13/56 (2006.01), *G01S 7/282* (2006.01),
G01S 7/32 (2006.01)
 (72) Inventeur/Inventor:
 MCEWAN, THOMAS E., US
 (73) Propriétaire/Owner:
 THE REGENTS OF THE UNIVERSITY OF CALIFORNIA,
 US
 (74) Agent: MARKS & CLERK

(54) Titre : COMMUNICATIONS A UTILISATION EXTREMEMENT EFFICIENTE DE LA BANDE PASSANTE
 (54) Title: ULTRA-WIDEBAND RADAR MOTION SENSOR



(57) Abrégé/Abstract:

A motion sensor is based on ultra-wideband (UWB) radar. UWB radar range is determined by a pulse-echo interval. For motion detection, the sensors operate by staring at a fixed ranged and then sensing any change in the averaged radar reflectivity at that range. A sampling gate is opened at a fixed delay after the emission of a transmit pulse. The resultant sampling gate output is averaged over repeated pulses. Changes in the averaged sampling gate output represent changes in the radar reflectivity at a particular range, and thus motion.

ABSTRACT OF THE DISCLOSURE

A motion sensor is based on ultra-wideband (UWB) radar. UWB radar range is determined by a pulse-echo interval. For motion detection, the sensors operate by staring at a fixed range and then sensing any change in the averaged radar reflectivity at that range. A sampling gate is opened at a fixed delay after the emission of a transmit pulse. The resultant sampling gate output is averaged over repeated pulses. Changes in the averaged sampling gate output represent changes in the radar reflectivity at a particular range, and thus motion.

ULTRA-WIDEBAND RADAR MOTION SENSOR

This is a divisional application of Canadian Patent Application Serial No. 2,160,352 filed on April 8, 1994.

BACKGROUND OF THE INVENTION

The invention relates generally to motion sensors and more particularly to motion sensors based on ultra-wideband radar. It should be understood that the expression "the invention" and the like encompasses the subject matter of both the parent and the divisional applications.

Motion sensors are primarily based on ultrasound, passive infrared (PIR) and radar detectors. Ultrasonic motion sensors are commonly used for automatic door openers and security alarms. They are of low cost and can operate with narrow beamwidths. However, installation options are limited since ultrasonic beams are easily blocked by thin materials, including paper. Another short-coming is the tendency to false trigger on reflections from blowing curtains or flying insects.

PIR sensors are perhaps the most frequently used home security sensor. They use a special Fresnel lens to generate multiple thermal images of a warm object, such as a person. As the person traverses the field of view, the thermal images produce periodic fluctuations as they sweep across an IR sensor element, which are then detected by low cost electronics. As with ultrasound, PIR can be blocked by a sheet of paper. Furthermore, PIR has no range adjustment.

FM-CW radar sensors emit a swept frequency microwave signal and compare the frequency of the echo with its current emission frequency, producing a beat frequency proportional to range. FM-CW radar sensors use low cost microwave oscillators and detector diodes, and audio frequency processing electronics to determine the audio beat frequency, or range. Non-ranging radar sensors simply emit a continuous microwave carrier and listen for a Doppler shift from a moving object. The antennas are usually low cost, die cast metal horns.

- 2 -

The main limitations to FM-CW and Doppler radar are: 1) limited materials penetration due to the high microwave frequencies employed, 2) microphonics caused by the use of short radar wavelengths combined with audio frequency processing, 3) frequency crowding, and 4) poor short-range operation. Short range performance is limited by close-in noise sidebands in the transmit oscillator, which must operate in the gigaHertz region and yet not have random frequency variations on the order of 100Hz, since this variation would be indistinguishable from the desired beat frequencies.

SUMMARY OF THE INVENTION

Ultra-wideband (UWB) radar motion sensing is a completely new approach to motion sensor technology. UWB radar operates as a pulse-echo system that clocks the two-way time of flight of a very short electrical pulse. A carrier frequency is not used; instead, an electrical voltage pulse is applied directly to the antenna.

Since frequency up-conversion by a modulator is not used, there is no frequency to tune in. The UWB transmit spectrum is the Fourier transform of the emitted pulse and generally spans hundreds of megaHertz to several gigaHertz. It is inherently spread-spectrum. A frequency allocation by the FCC is not relevant. Furthermore, many independent UWB sensors may be co-located without interference.

By not using frequency up-conversion, the UWB spectrum is located as close to DC as possible. Since most materials exhibit rapidly increasing attenuation with frequency, UWB radar has a very significant advantage in materials penetration. Tests show that 200ps pulses freely penetrate gypsum, wood, and concrete walls. Excellent materials penetration is a fundamental advantage to UWB sensors, and will allow their installation behind walls and appliance panels, above ceilings and below floors.

UWB radar range is determined by the pulse-echo interval. For motion detection, the sensors operate by staring at a fixed range and then sensing any change in the averaged radar reflectivity at that range. This is accomplished by opening a sampling gate at a fixed delay after the emission of the transmit pulse, and then averaging the resultant sampling gate output over repeated pulses. Changes in the averaged sampling gate output represent changes in the radar reflectivity at a particular range, and thus motion.

An invisible, constant-range spherical shell is effectively projected into space, the thickness of which is directly related to the radar pulse width. In two illustrative embodiments, one sensor has a shell thickness of one inch, and the other about 18 inches.

The location of the detection shell is set by adjusting the sampling gate delay. This delay adjustment is easily implemented, and can be adjusted down to point blank range with no performance penalty. User adjustable detection range is another outstanding feature of UWB sensors.

The cost of UWB motion sensors will be on a par with competing sensors, so its selection as the most appropriate sensor technology for many applications will be assured. Near term UWB sensors will be built with off-the-shelf components. Eventually, a silicon, application specific integrated circuit (ASIC) may embody all the sensor electronics.

UWB motion sensor electronics may also be connected to electro-optical transducers, such as light emitting diodes and PIN photodiodes to project the detection shell optically. This would be particularly useful where pencil beam sensing, i.e., "light saber" operation is desired.

According to an aspect of the present invention there is provided an ultra-wideband (UWB) radar motion sensor, comprising:

- a pulse repetition interval generator;
- a fixed reference delay means connected to the pulse repetition interval generator;
- a transmit pulse generator connected to the reference delay means;
- a transmit antenna connected to the transmit pulse generator;
- an adjustable delay means connected to the pulse repetition interval generator;
- a gating pulse generator connected to the adjustable delay means;
- an UWB radar receiver connected to the gating pulse generator;
- a receiver antenna connected to the UWB receiver;
- signal processing means connected to the UWB receiver, the signal processing means including narrowband signal processing means.

According to another aspect of the present invention there is provided an ultra-wideband (UWB) radar motion sensor, comprising a pulse repetition interval generator, a fixed reference delay means connected to the pulse repetition interval generator, a transmit pulse generator connected to the reference delay means, a transmit

3a

antenna connected to the transmit pulse generator, an adjustable delay means connected to the pulse repetition interval generator, a gating pulse generator connected to the adjustable delay means, an UWB radar receiver connected to the gating pulse generator, a receiver antenna connected to the UWB receiver, and signal processing means connected to the UWB receiver, wherein the UWB receiver includes a sampler which accumulates effects of a plurality of signals on the receiver antenna in response to a corresponding plurality of gating pulses generated by the gating pulse generator to produce a sampler signal.

According to a further aspect of the present invention there is provided an ultra-wideband (UWB) radar motion sensor, comprising a pulse repetition interval generator, a fixed reference delay means connected to the pulse repetition interval generator, a transmit pulse generator connected to the reference delay means, a transmit antenna connected to the transmit pulse generator, an adjustable delay means connected to the pulse repetition interval generator, a gating pulse generator connected to the adjustable delay means, an UWB radar receiver connected to the gating pulse generator, a receiver antenna connected to the UWB receiver, and signal processing means connected to the UWB receiver, wherein the transmit pulse generator comprises circuitry biased for operation in a non-avalanche mode which supplies a transmit pulse to the transmit antenna.

According to a further aspect of the present invention there is provided an ultra-wideband (UWB) radar motion sensor, comprising a pulse repetition interval generator, a fixed reference delay means connected to the pulse repetition interval generator, a transmit pulse generator connected to the reference delay means, a transmit antenna connected to the transmit pulse generator, an adjustable delay means connected to the pulse repetition interval generator, a gating pulse generator connected to the adjustable delay means, an UWB radar receiver connected to the gating pulse generator, a receiver antenna connected to the UWB receiver, and signal processing means connected to the UWB receiver, wherein the receiver comprises an integrating sampler.

According to a further aspect of the present invention there is provided an ultra-wideband (UWB) radar motion sensor, comprising a pulse repetition interval generator, a fixed reference delay means connected to the pulse repetition interval generator, a transmit pulse generator connected to the reference delay means, a transmit antenna connected to the transmit pulse generator, an adjustable delay means connected

3b

to the pulse repetition interval generator, a gating pulse generator connected to the adjustable delay means, an UWB radar receiver connected to the gating pulse generator, a receiver antenna connected to the UWB receiver, and signal processing means connected to the UWB receiver, wherein the receiver comprises a differential integrating sampler.

According to a further aspect of the present invention there is provided an ultra-wideband (UWB) radar motion sensor, comprising a pulse repetition interval generator, a fixed reference delay means connected to the pulse repetition interval generator, a transmit pulse generator connected to the reference delay means, a transmit antenna connected to the transmit pulse generator, an adjustable delay means connected to the pulse repetition interval generator, a gating pulse generator connected to the adjustable delay means, an UWB radar receiver connected to the gating pulse generator, a receiver antenna connected to the UWB receiver, and signal processing means connected to the UWB receiver, wherein the receiver comprises an integrating sampler, and the signal processing means comprises an integrator which smooths the output of the integrating sampler, and a differentiator which differentiates the output of the integrator to obtain target motion information.

According to a further aspect of the present invention there is provided an ultra-wideband (UWB) radar motion sensor, comprising a pulse repetition interval generator, a fixed reference delay means connected to the pulse repetition interval generator, a transmit pulse generator connected to the reference delay means, a transmit antenna connected to the transmit pulse generator, an adjustable delay means connected to the pulse repetition interval generator, a gating pulse generator connected to the adjustable delay means, an UWB radar receiver connected to the gating pulse generator, a receiver antenna connected to the UWB receiver, and signal processing means connected to the UWB receiver, wherein the transmit pulse generator comprises a circuit producing antenna ring down pulses on the transmit antenna.

According to a further aspect of the present invention there is provided an ultra-wideband (UWB) radar motion sensor, comprising a pulse repetition interval generator, a fixed reference delay means connected to the pulse repetition interval generator, a transmit pulse generator connected to the reference delay means, a transmit antenna connected to the transmit pulse generator, an adjustable delay means connected to the pulse repetition interval generator, a gating pulse generator connected to the adjustable delay means, an UWB radar receiver connected to the gating pulse generator, a

3c

receiver antenna connected to the UWB receiver, and signal processing means connected to the UWB receiver, wherein the UWB receiver includes resources to receive return echoes for a plurality of ranges, including a first range and a second range difference than the first range.

According to a further aspect of the present invention there is provided an ultra-wideband (UWB) radar motion sensor, comprising a pulse repetition interval generator, a fixed reference delay means connected to the pulse repetition interval generator, a transmit pulse generator connected to the reference delay means, a transmit antenna connected to the transmit pulse generator, an adjustable delay means connected to the pulse repetition interval generator, a gating pulse generator connected to the adjustable delay means, an UWB radar receiver connected to the gating pulse generator, a receiver antenna connected to the UWB receiver, and signal processing means connected to the UWB receiver, wherein the receiver comprises an input node coupled to the receive antenna, a diode having an anode and a cathode, the anode coupled to the input node, and the cathode coupled to the gating pulse generator, a capacitive node coupled to the anode of the diode at which effects of a plurality of pulses accumulate.

According to a further aspect of the present invention there is provided an ultra-wideband (UWB) radar motion sensor, comprising a pulse repetition interval generator, a fixed reference delay means connected to the pulse repetition interval generator, a transmit pulse generator connected to the reference delay means, a transmit antenna connected to the transmit pulse generator, an adjustable delay means connected to the pulse repetition interval generator, a gating pulse generator connected to the adjustable delay means, an UWB radar receiver connected to the gating pulse generator, a receiver antenna connected to the UWB receiver, and signal processing means connected to the UWB receiver, wherein the receiver comprises a first input node coupled to the receive antenna, a first diode having an anode and a cathode, the anode coupled to the first input node, and the cathode coupled to the gating pulse generator, a first capacitive node coupled to the anode of the diode at which a first signal reflecting effects of a plurality of pulses accumulate, a second input node coupled to the receive antenna, a second diode having an anode coupled to the second input node and a cathode coupled to the gating pulse generator, a second capacitive node coupled to the anode of the second diode at which a second signal reflecting effects of a plurality of pulses accumulate, and a circuit to combine the first signal and the second signal to produce a receiver output.

3d

According to a further aspect of the present invention there is provided an ultra-wideband (UWB) radar motion sensor, comprising a pulse repetition interval generator, a fixed reference delay means connected to the pulse repetition interval generator, a transmit pulse generator connected to the reference delay means, a transmit antenna connected to the transmit pulse generator, an adjustable delay means connected to the pulse repetition interval generator, a gating pulse generator connected to the adjustable delay means, an UWB radar receiver connected to the gating pulse generator, a receiver antenna connected to the UWB receiver, and signal processing means connected to the UWB receiver, wherein the pulse repetition interval generator, fixed reference delay means, transmit pulse generator, adjustable delay means, gating pulse generator, UWB radar receiver, and signal processing means comprise elements on a single integrated circuit.

According to a further aspect of the present invention there is provided an ultra-wideband (UWB) radar motion sensor, comprising a pulse repetition interval generator, a fixed reference delay means connected to the pulse repetition interval generator, a transformerless transmit pulse generator connected to the reference delay means, a transmit antenna connected to the transmit pulse generator, an adjustable delay means connected to the pulse repetition interval generator, a gating pulse generator connected to the adjustable delay means, an inductorless UWB radar receiver connected to the gating pulse generator, a receiver antenna connected to the UWB receiver, and signal processing means connected to the UWB receiver.

According to a further aspect of the present invention there is provided an ultra-wideband (UWB) radar sensor, comprising:

- a pulse repetition interval generator;
- a fixed reference delay means connected to the pulse repetition interval generator;
- a transmit pulse generator connected to the reference delay means;
- a transmit antenna connected to the transmit pulse generator;
- an adjustable delay means connected to the pulse repetition interval generator;
- a receiver antenna;
- a gating pulse generator connected to the adjustable delay means ;
- an UWB radar receiver connected to the gating pulse generator and to the receiver antenna, said UWB radar receiver detecting reflected UWB radar pulses from a predetermined range and producing a detection output signal indicative of a plurality of

3e

said pulses, said UWB radar receiver comprising means for integrating said reflected UWB radar pulses, said detection output signal corresponding to an average of said plurality of said reflected pulses; and

signal processing means for processing said detection output signal, said signal processing means being connected to the UWB receiver and comprising integrating means producing an average output signal corresponding to a further average of said plurality of said reflected pulses, said sensor being such as to sense motion.

According to a further aspect of the present invention there is provided an ultra-wideband (UWB) radar sensor, comprising means for transmitting UWB radar pulses, means for receiving and processing reflected UWB radar pulses by detecting the reflected UWB radar pulses from a predetermined range and by producing a baseband detection output signal indicative of a plurality of the pulses, wherein the means for receiving and processing further comprises means for integrating the reflected UWB radar pulses, the detection output signal corresponding to an average of the plurality of the reflected pulses, means for integrating the baseband detection output signal, thereby producing a baseband average output signal corresponding to a further average of the plurality of the reflected pulses, and means for differentiating baseband average output signals produced at different times, thereby detecting motion.

According to a further aspect of the present invention there is provided an ultra-wideband (UWB) radar sensor, comprising:

a pulse repetition interval generator;

a fixed reference delay means connected to the pulse repetition interval generator;

a transmit pulse generator connected to the reference delay means;

a transmit antenna connected to the transmit pulse generator;

an adjustable delay means connected to the pulse repetition interval generator;

a receiver antenna;

a gating pulse generator connected to the adjustable delay means ;

an UWB radar receiver connected to the gating pulse generator and to the receiver antenna, said UWB radar receiver detecting reflected UWB radar pulses from a predetermined range and producing a detection output signal, said UWB radar receiver comprising means for holding a plurality of said reflected UWB radar pulses over a sampling period; and

signal processing means for processing said detection output signal, said signal processing means being connected to the UWB receiver and comprising integrating means producing an average output signal corresponding to an average of said plurality of said reflected pulses, said sensor being such as to sense motion.

BRIEF DESCRIPTION OF THE DRAWINGS

Figure 1 is a block diagram of a UWB radar motion sensor.

Figure 2 illustrates a UWB radar constant range shell.

Figures 3a-d are various UWB radar motion detection signals.

Figure 4 is a schematic diagram of a UWB receiver in a UWB radar motion detector.

Figure 5 is a schematic diagram of a UWB radar motion sensor.

Figure 6 is a schematic diagram of a VHF medium range UWB radar motion sensor.

Figure 7 shows dipole antenna pair ringdown.

Figures 8a-b show UWB spectrum with non-dithered and dithered PRI operation.

Figure 9 illustrates dual shell velocity measurement.

Figure 10 is a schematic diagram of a time multiplexed dual range shell velocity measurement system.

- 4 -

Figure 11 is a schematic diagram of a dual delay velocity measurement system.

Figure 12A is a schematic diagram of a modulated Colpitts RF oscillator circuit.

Figure 12B is an output signal from the circuit of Figure 12A.

DETAILED DESCRIPTION OF THE PREFERRED EMBODIMENTS

Referring to Figure 1, a free-running oscillator (PRI generator) 20 generates the radar pulse repetition interval (PRI). Typically, this interval is $1\mu\text{s}$. A noise generator 22 is connected to the PRI generator 20 to introduce a random variation to the PRI, for purposes to be described below. The output of the PRI generator 20 drives two delay means, a fixed reference delay means 24 in the transmit path 26, and an adjustable delay means 28 in the receive (gating pulse) path 30. Delay means 28 is adjusted by range adjustment means 32.

The reference delay means 24 is generally set to match the minimum delay in the receive path 30, and may also be set to account for delays in the antenna feed lines, etc. The output of the reference delay means 24 drives an impulse (or step) generator 34 which provides the transmit pulse. If PRI generator 20 or reference delay means 24 produce a pulse with sufficiently fast rise time, then impulse (or step) generator 34 may be omitted. Otherwise, generator 34 is used to generate a suitable transmit pulse. The transmit pulse typically resembles a Gaussian shaped voltage pulse. In general, it is not a modulated RF pulse. The UWB radar differs from conventional radar in that no carrier frequency is used. Rather, a sequence of individual pulses, spaced by the PRI, is applied directly to the antenna.

The transmit pulse is directly radiated by the transmit antenna 36. There are several UWB antennas in common use, the most common of which is the tapered slot antenna, also known as an endfire antenna. In preferred embodiments, both simple wire dipoles and broader band "bow-tie" dipoles are used. Due to their resonant nature, ringing is produced in the emitted radiation, but this effect is put to use, as will be described below.

Since many antennas exhibit increasing gain with increasing frequency, a step input applied to the transmit antenna will result in the radiation of the derivative of the step, i.e., an impulse. In

- 5 -

the embodiments of Figures 5 and 6, a voltage step is applied to the transmit antenna. Both the transmit and receive antenna feedline may contain spectrum limiting or shaping filters for various purposes known to those skilled in the art.

The receive antenna 38 is connected to a UWB detector (receiver or sampler) 40, which is described in United States Patent No.

5,345,471. The UWB detector may also be a wideband sampling circuit, such as those incorporated by Tektronix, Inc. and Hewlett-Packard, Inc. in their standard sampling oscilloscopes. The sampler 40 is gated or strobed by the output of the adjustable delay 28 through impulse (or step) generator 42, thus causing the sampler 40 to sample a point in space corresponding to the two-way echo time to the target 44. Again, impulse/step generator 42 may be omitted if the adjustable delay pulse has sufficiently short risetime.

The output of the UWB detector 40 is averaged in an integrator 46 with a time constant that is substantially longer than the PRI of the radar, typically 10ms in a motion sensor. At a PRI of 1 μ s, 10,000 pulses are averaged. This average value represents the sum of the radar reflections and other radar clutter, such as direct antenna to antenna coupling.

The method can be implemented by averaging two or more pulses. However, preferably a large number, i.e. 1,000 to 10,000 pulses, will be averaged. The transmitted pulses typically have a pulse width of about 5ns or less, and more preferably about 1ns or less. The PRI typically is in the range of 100ns to 100ms.

If the radar reflectivity changes at the range being sampled, the average will change, and this change is sensed by the differentiator 48. The output of the differentiator 48 triggers a comparator circuit 50, which in turn can activate an alarm. Comparator 50 compares the output of differentiator 48 to a preset V_{ref} . The sensitivity is controlled by V_{ref} .

For simplicity, this invention uses an analog integrator and differentiator. A digital equivalent may be used at added complexity. In linear systems, the order of the integrator and differentiator may be interchanged. Further, the cascaded integration and differentiation

- 6 -

process resembles a bandpass filter in the frequency domain, and so a bandpass filter 52 may be used for this combined function. Typical filter constants are: low frequency corner at 1Hz and high frequency corner at 10Hz, for motion sensing of people.

The UWB pulse-echo system 54 typically operates at a constant sampling delay, or at a constant range, as depicted in Figure 2. Due to the short impulse emitted, an effective spherical shell 56 is projected in space. The thickness of the shell is directly related to the sampling pulse width, which is generally set to be equal to the transmit pulse width T . The constant range shell then has a thickness of $cT/2$ where c is the pulse velocity.

Figures 3a-d show data obtained from the UWB radar of Figure 5. The horizontal scales are a slow time axis, corresponding to a 2 second time lapse. The vertical scale is the output from the UWB detector-integrator-differentiator. In Figures 3a-d, a human hand is inserted into and then removed from the shell within the two second time scale, and the resulting signals are indicated for several ranges (1 ft. in Figure 3a, 4 ft. in Figure 3b, 15 in. in Figures 3c-d), and with several materials (6 in. of text books in Figure 3c, 2 in. of concrete in Figure 3d) between the radar and the target. Both insertion and removal of the hand are clearly shown.

Figure 4 shows a differential UWB receiver designed for use in UWB radar motion detector. A broadband dipole antenna 58 is connected to a twisted pair transmission line 60. Each wire of line pair 60 is connected through a capacitor $C1$ or $C2$ and series resistor $R1$ or $R2$ to the positive input of an operational amplifier $A1$ or $A2$. The junctions between $C1-R1$ and $C2-R2$ are connected to a pair of diodes $D1$, $D2$ whose anodes are connected to the junctions and whose cathodes are connected together. A gating pulse is applied to the common cathode junction between $D1-D2$. The gating pulse line may include a capacitor $C5$. The input line pair 60 and gating pulse input line are all terminated in resistors R_T . The positive inputs of $A1$, $A2$ are also connected through resistors $R3$, $R4$ respectively to a + Bias voltage. The positive inputs of $A1$, $A2$ are also connected through capacitors $C3$, $C4$ to ground. $C3$ and $C4$ can be omitted if there is sufficient input capacitance on $A1$, $A2$, or if RF rejection is not necessary or desired. The output of $A1$ is connected through $C5$ and $R5$ to the negative input of operational

- 7 -

amplifier A3 and the output of A2 is connected to the positive input of A3. The output of A3 is fed back to the negative input of A3 through capacitor C6 and parallel variable resistor R6. Resistor R6 is adjusted to control sensitivity. The negative inputs of A1, A2 are connected together through C7 and R7 and are connected to the output of A1, A2 through C8 and parallel R8.

In an illustrative embodiment $C1=C2=22\text{pF}$, $R1=R2=10\text{K}$, $R_T=68\text{ ohm}$, D1 and D2 are M-Pulse MP2612 diodes, the gate pulse is -8V with 200ps edge and $1\mu\text{s}$ PRI generated by Metellics step recovery diode MMD 805-828 input through a 0.5 pF capacitor, $R3=R4=10\text{M}$, $+Bias=+5\text{V}$, $C3=C4=0.01\mu\text{F}$, A1-A3 are TL074 op amps, $C5=220\mu\text{F}$, $R5=1\text{K}$, $C6=0.2\mu\text{F}$, $R6=100\text{K}$ (variable), $C7=4.7\mu\text{F}$, $R7=47\text{K}$, $C8=3300\text{pF}$, $R8=2.2\text{M}$. If C3, C4 are omitted, then $C1=C2=0.01\mu\text{F}$.

Figure 5 is a schematic of a micropower UWB radar motion sensor. A series of CMOS logic gates (labeled I1) form the PRI generator (33kHz oscillator) 21, which is connected through buffer gates (I2) to the delay circuits 23a,b and the impulse generators 25a,b. Noise generator 19 is connected to oscillator 21. The delay means 23a is just the wire (i.e. no delay), while the delay means 23b is formed of the resistors associated with switch S. The impulses are finally generated by step recovery diodes (SRD), supplied by Metellics Corp. of Sunnyvale, CA and specified to produce 100ps transitions or faster. The transmit (T) and receiver (R) antennas are $6''$ bow-tie shaped dipoles or $3''$ wire monopoles. The UWB receiver 27 formed of op amps (I3) is of the type shown in Figure 4 and contains the integrator and differentiator in the form of various capacitors associated with the circuit. The switch S in the gating pulse path and in the UWB receiver is used to select the range ($6'$ or $12'$). An alarm circuit 29 is comprised of op amps I4, and includes a bipolar comparator and a driver circuit to sound an alarm after detection. The IC's are I1=CD4069, I2=74HC04, I3=TLC27L4, I4=TLC27L2. Not shown are a $+3\text{V}$ voltage regulator and $+6\text{V}$ penlight batteries. Because of the low duty cycle and small power consumption, the batteries last for several years in continuous operation.

Figure 6 shows a VHF security alarm circuit, operating at a transmit pulse width of 2ns . The waveform that is applied to the $18''$ dipole antenna 31 is essentially a voltage step that is effectively differentiated, with ringing, by the antenna. The PRI generator (100 kHz

- 8 -

oscillator) 21, and buffers in the transmit and receive (strobe) paths are formed by CMOS IC's I1 and I2, which are 74HC04 invertors. This IC costs less than \$0.50 and generates stable, jitter-free delays from zero to 200ns. Delay means 23a provides no delay, while delay means 23b is formed of potentiometer R. The impulse generators 25a,b include transistors Q1=2N5109 and Q2=2N2369. Noise generator 19 is connected to oscillator 21. The two halves 31a,b of a dipole antenna are connected to the inputs of UWB receiver 27 which drives alarm circuit 29. The IC's are I3=TLC27L4 and I4=TLC27L2 op amps. The Schottky diodes D are 1N5711. Range delay adjustment is provided by a simple potentiometer R in the strobe line. This circuit is similar to Figure 5. It runs on batteries and its antennas are one meter in length rather than 6".

The invention is thus based on RCS (radar cross section) averaging at a fixed range cell using averaging circuits, plus averaged RCS change detection. A fixed range is stared at, and a large number of return pulses are averaged. Changes in the average are then sensed as motion.

The invention also includes RCS averaging across a range sweep using averaging, plus averaged RCS change detection. Virtually all pulse-echo radars sweep the adjustable delay, or range delay, across a span while averaging a relatively small number of pulses, so individual "blips" may show up. In this invention, the averaging time constant can be set to be larger than the range scan time such that the entire sweep is averaged. Changes in this average represent motion somewhere within the range sweep.

Although individual "blips", or targets at particular ranges are diminished by the averaging process, noise levels are equally reduced by the averaging process, so the signal-to-noise ratio for changes in the blip remains the same. UWB reflections off people are a highly variable function of aspect angle, so a person moving within the averaged range sweep will produce a detectable fluctuation. This sweep averaging technique is intended as a simplification to UWB motion sensor hardware.

The invention also includes an antenna ringdown method of motion detection across a range span, using averaging circuits, plus averaged RCS change detection. Figure 7 shows typical antenna ringdown produced by a transmit/receive dipole pair when excited by a

- 9 -

fast rising voltage step. UWB motion sensors operate primarily at a detection range corresponding to the time of flight of the leading edge of the transmitted pulse. Ringing that is trailing the leading edge appears later in time, while in space, ringing appears at a range closer to the radar, for a fixed sampling delay. Thus, for a given range delay setting, ringing pulses generate an outermost detection shell corresponding to the leading pulse, and successive inner detection shells located by the periodicity of the ringing.

The advantage to ringing is that it generates an effective range sweep since multiple ranges become active for motion sensing. Yet, range sweeping hardware is eliminated and the use of simple dipole antennas is allowed.

Another advantage to this technique, or to an averaged range sweep, is that if a target manages to evade the outer detection shell, the inner shells may still be activated. This situation occurs when the target echo from the outer range shell is too small to be detected. It also prevents a person from walking up to a UWB motion detector without setting it off.

As the antenna rings down, ringing amplitude decreases. Since successive ringing cycles appear at closer range, diminished amplitude helps maintain constant sensitivity.

Additional methods of radiating a ringdown waveform that provide enhanced compatibility with U.S. Federal Communication Commission regulations include 1) shock exciting a tuned circuit or bandpass filter with a voltage impulse/step, or 2) using a voltage impulse/step to modulate an oscillator. The first case is similar to selecting a harmonic of a frequency comb generator, where the frequency comb generator is represented by the impulse/step generator 34 in Figure 1 and the tuned circuit/bandpass filter 35 is an element inserted between the impulse/step generator 34 and the transmit antenna 36. The finite Q or damping factor of the tuned circuit/bandpass filter leads to a damped sinusoidal waveform at each repetition. This damped waveform can then be applied to either a resonant or non-resonant antenna 36.

The second ringdown method involves inserting a modulated oscillator between the step generator 34 and the antenna 36. Figure 12A shows a modulated Colpitts RF oscillator circuit that generates a ring-down waveform. Colpitts oscillators are well-known in

- 10 -

the art. However, this oscillator differs in its modulation method. The Colpitts oscillator 80 is driven by a CMOS logic inverter 82 through a modulation envelope shaping network 84, which includes capacitor 83 and series resistor 85. The shaping network 84 resistor-capacitor component values can be adjusted to provide nearly arbitrary effective damping factors, ranging from a Q of <1 (less than one oscillation cycle) to nearly infinite (steady oscillation). In operation, a negative-going logic transition from the CMOS inverter couples through the shaping network and biases the Colpitts oscillator transistor Q1 on, and the oscillator generates a limited number of cycles of decreasing amplitude in correspondence to the decaying drive current provided by shaping network. A step recovery diode 86 and a bias resistor 88 are included to sharpen the drive from the CMOS inverter to provide a rapid start-up drive to the Colpitts oscillator, resulting in the lack of an oscillation build-up time as evidenced by the oscillator output data in Figure 12B. If the oscillator has a slow build-up time, the radar range boundary will not be sharp. Transistor Q1 is a Motorola MMBR920L, the logic inverter is a Texas Instruments 74HC04 and the step recovery diode is a common computer diode type 1N4148.

The preferred damping factor is that which tends to maintain constant motion sensitivity within the range gate—typically 10-100 cycles to damp to the 37% point. The modulation envelope may be set to other than a damped sinusoid, but would be less preferred—except when the shape of the modulation envelope is used to help control the radiated spectrum for emission compatibility with regulatory agency rules.

The invention further includes randomly or pseudo-randomly dithered PRI operation. Figure 8a shows the UWB emission spectrum when the PRI is steady, or is not dithered. It consists of spectral lines located at harmonics of the pulse repetition frequency (PRF). The envelope formed by the spectral lines is identical in shape to the spectrum produced by a single impulse. (The tall spikes are local TV stations.)

If either random noise or code-generated pseudo-random PRI modulation, or dither, is added, as shown in Figure 8b, the emission spectrum can be spread to resemble the shape of a single impulse. Since the energy that was concentrated in individual lines is spread out, the

- 11 -

peak amplitude of the spectrum is reduced. Interference to conventional receivers is reduced accordingly, and resembles thermal noise.

PRI dithering affects the pulse repetition interval only, and not the pulse-echo delay time. While most commercial sampling circuits do not tolerate PRI dither, the receiver circuits used in this invention have excellent independence from PRI variations.

A high level of pulse integration, e.g., 10,000 pulses, averages out interference in the receiver, and is thus a form of time domain tuning, since it accomplishes in the time domain what tuned circuits accomplish in the frequency domain. However, if an interfering signal has a frequency that is close to a multiple of the radar PRF, beat frequencies can form that appear in the averaged signal, (although this has not been observed in practice). By applying PRI dither, the same amount of averaging occurs, but there is no steady PRF with which to form beat frequencies. PRI dither is not per se unique, but is utilized here in UWB motion sensors.

According to the invention, the noise spectrum should lie above the UWB detection bandwidth. This reduces or eliminates any residual dither noise appearing at the UWB detector output, and eases the noise rejection requirements imposed on the UWB detector.

The invention further provides absolute velocity measurement using dual range motion sensing. In automotive and other applications, motion sensing plus velocity measurement is desirable. Figure 9 shows a dual detection shell scheme which is based on either of two methods described below to project two detection shells. As the target 62 traverses the shells 64 and 66 at R1 and R2, motion signals are generated which are detected by UWB motion sensor 68. The time difference between the detection events stemming from R1 and R2 can be used to determine radial velocity. The dual range principles can be extended to more than two shells or ranges.

One dual detection scheme is time multiplexed dual range operation. Figure 10 depicts the scheme of Figure 1 with a time multiplexed range circuit added. A squarewave oscillator 70 runs at a slower rate than the PRF, e.g., at 0.5 PRF, so the radar alternately ranges at R1 for a period and then R2 for a period. As the detection range is alternated, an analog switch 72 is toggled in synchronism, such that the two range signals from the UWB detector are routed to separate

- 12 -

integrators and motion detection circuits 74a,b. The remaining components are the same as in Figure 1.

The squarewave period is much shorter than the shortest traverse time associated with R1 and R2. In practice, R1 and R2 may differ by one foot, and for the fastest automotive environment, the R1-R2 traversal would be several milliseconds, much longer than the $\sim 1\mu\text{s}$ period of the squarewave oscillator.

Thus, with the addition of a small amount of circuitry, velocity can be measured. This feature does not require additional antennas. Unlike Doppler techniques, very low velocities can be measured.

The other dual detection scheme is based on dual receive channels with a delay inserted into one channel. Figure 11 depicts a dual shell velocity measurement scheme using the basic motion detector of Figure 1 with an additional complete receiver channel 30b added. The second receiver 40b senses at a different range by having a cable delay 76 inserted in its antenna feedline. Alternately, a delay 78 can be inserted in the strobe line, e.g. in line 30a to receiver 40a. The remaining components are similar to Figures 1 and 10.

This system requires an additional antenna and a complete receiver, and thus is not preferred over the time multiplexed dual range system.

Unique features of UWB motion sensors are: excellent materials penetration; a sharply bounded, adjustable active range; low cost; multi-sensor operation; and potential for single chip implementation. This array of features will enable many new applications, the range of which is limited mainly by one's imagination. A few of the more prominent applications are the following:

Security Systems: UWB motion sensors may be placed behind walls, above ceilings, and below floors. One possible home installation would place UWB motion sensors above each room in the house and have their detection ranges set to six feet. At that range, the detection shell would reach down to a level that detects people, but would exclude detection of pets near the floor. In one test of the 100ps motion sensor of Figure 5, it was pointed through a wall into a hallway, and the range was set to span most of the width of the hallway. If a

- 13 -

person hugged the far wall of the hallway, detection could be evaded, but an unknowing person would always be detected.

The area in front of a garage door can be protected by placing a UWB sensor inside the garage where it would be unseen by burglars, and where installation is simplified.

A single UWB VHF sensor may be placed in the center of a home and set to a detection range that projects an invisible detection shell around the entire house, providing complete home protection from a single, low-cost sensor. This concept has been successfully tested using the system of Figure 6.

For police work, UWB sensors can be discretely placed outside rooms that are to be monitored for activity. Using the battery powered UWB VHF radar of Figure 6, the sensitivity could be set so high that the slightest motion of a person in an adjacent room is detected. It does not appear possible for a living person to remain still enough to not set it off.

Novel Home Uses: UWB sensors can be built into junction boxes for use as concealed light switches and door openers. Homes of the future may have an invisible region near a wall where a hand can be waved to turn a light on. Doorways may be monitored by concealed UWB sensors to open them and turn lights on. UWB sensors may also help the handicapped.

Intelligent Appliances: With their unique ability to operate through plastic panels and to operate at close range, UWB sensors will find use in intelligent appliances that sense the presence of a person, or a person's hand, and respond accordingly. Lights can be turned on, doors can be opened, machines can be turned off for safety or convenience, ovens can be deactivated, etc.

Life Detector For Disaster Work: Buried earthquake and avalanche victims may be located with highly sensitive UWB detectors. The superior penetration capability of UWB radar, as well as excellent close-range operation and high sensitivity will enhance prior work using FM-CW radar. The UWB VHF radar of Figure 6 has detected respiration and possibly heartbeats at a 10 foot range.

Medical Applications: The 100ps UWB radar of Figure 5 has detected heart beats and arterial pulses at near-zero range (surface contact). Although most of the detected signal may be due to skin

- 14 -

motion, there appears to be a deeper component. The medical significance is not known at this time. UWB radiation levels are well below the OSHA limit for continuous exposure to microwaves.

Automotive Collision Sensor: Most of the radar community has focused on millimeter-wave (MMW) radars for automotive use. Current cost projections for these radars are \$500 or more. Some of these radars are very microphonic, since the MMW-radar wavelengths and mechanical vibrations are of similar dimensions. Further, MMW radars will require windshield wipers due to their inability to penetrate water, mud and snow cover. MMW radar proponents overlook the fundamental fact that radar works best when the radar wavelength is on the same order as the target dimensions.

Thus, one or two meter wavelength VHF radar would be most appropriate for sensing automobiles.

UWB VHF radar antennas may consist of elementary wire dipoles embedded in plastic body sections or embedded in windows. Although the overall dipole length should be on the order of 0.5 - 1.0 meters, considerably shorter dipoles will also work since the limited detection range and large radar cross section of cars permits operation with high system losses.

Detection ranges from 1 to 10 feet are practical with omnidirectional antennas. Using antennas embedded in the tail light and parking light lenses, detection shells can be projected to cover the rear, sides and front of the vehicle. These antennas may be connected to a central UWB module using low cost coaxial cables. The cost of the UWB module could be on the order of \$10. Triangulation might eventually be used to achieve sharply-controlled synthetic beamwidths.

UWB motion sensing offers three levels of alarm discrimination: radar cross-section, or object size; precise detection range; and velocity measurement. All of these discriminants may easily be scaled to match vehicle speed.

Changes and modifications in the specifically described embodiments can be carried out without departing from the scope of the invention which is intended to be limited only by the scope of the claims.

The embodiments of the invention in which an exclusive property or privilege is claimed are defined as follows:

1. An ultra-wideband (UWB) radar motion sensor, comprising:
 - a pulse repetition interval generator;
 - a fixed reference delay means connected to the pulse repetition interval generator;
 - a transmit pulse generator connected to the reference delay means;
 - a transmit antenna connected to the transmit pulse generator;
 - an adjustable delay means connected to the pulse repetition interval generator;
 - a gating pulse generator connected to the adjustable delay means;
 - an UWB radar receiver connected to the gating pulse generator;
 - a receiver antenna connected to the UWB receiver;
 - signal processing means connected to the UWB receiver, the signal processing means including narrowband signal processing means.
2. The sensor of claim 1 further comprising alarm means connected to the signal processing means.
3. The sensor of claim 1 further comprising a noise generator connected to the pulse repetition interval generator.
4. The sensor of claim 1 further comprising range adjustment means connected to the adjustable delay means.
5. The sensor of claim 1 wherein the signal processing means comprises an integrator followed by a differentiator.
6. The sensor of claim 1 wherein the signal processing means is a bandpass filter.

7. The sensor of claim 1 wherein the pulse repetition interval generator is a dithered pulse generator.
8. The sensor of claim 1 further comprising a square wave oscillator connected to the adjustable delay means for repetitively switching between two fixed ranges and an analog switch connected to the output of the UWB receiver and to the square wave oscillator for switching the UWB receiver output to separate motion detectors for each range.
9. The sensor of claim 1 further comprising a second UWB radar receiver connected to the gating impulse generators, a second receiver antenna connected to the second UWB receiver, and a delay line positioned either between the second receiver antenna and second UWB receiver, or in between the gating impulse generator and one of the UWB receivers.
10. The sensor of claim 1, further including means for averaging about 1,000 to 10,000 pulses.
11. The sensor of claim 1 wherein the transmit and receiver antennas are formed of a dipole pair which exhibits antenna ringdown.
12. The sensor of claim 1 wherein the transmit pulse generator comprises a logic gate connected to a step recovery diode.
13. The sensor of claim 1 wherein the transmit pulse generator comprises a logic gate connected to a high speed bipolar transistor.
14. The sensor of claim 1 wherein the adjustable delay means comprises a resistor-capacitor (RC) network between a first logic gate and a second logic gate.
15. The sensor of claim 1 wherein the pulse repetition interval generator comprises a CMOS oscillator.

16. The sensor of claim 1 wherein the pulse repetition interval generator comprises a resistor-capacitor (RC) oscillator with a nonlinear resistance network.
17. The sensor of claim 7 wherein the dithered pulse generator comprises a bipolar transistor, a base resistor, and an amplifier.
18. The sensor of claim 2 wherein the alarm means triggers on an increase or decrease in average detected signal.
19. The sensor of claim 1 wherein at least one of the transmit pulse generator and the gating pulse generator comprises means to limit the pulse width or duty cycle.
20. The sensor of claim 1 wherein the transmit antenna comprises a single dipole with the transmit pulse applied to one terminal of the dipole and the receiver connected to one or both terminals of the dipole.
21. The radar motion sensor of claim 1, wherein the receiver has a sensitivity to detect reflections of a transmitted signal from a reflecting body at a range of 1-12 feet from the receiver antenna.
22. The radar motion sensor of claim 1, wherein the transmit antenna and the receiver antenna comprise a shared element.
23. The radar motion sensor of claim 1, wherein the transmit pulse generator, gating pulse generator and UWB radar receiver, comprise elements operating with a maximum power supply voltage of 6 volts.
24. The radar motion sensor of claim 1, wherein the pulse repetition interval generator, fixed reference delay means, transmit pulse generator, adjustable delay means, gating pulse generator, UWB radar receiver, and signal processing means comprise elements operating with a maximum power supply voltage of 6 volts.

25. The radar motion sensor of claim 1, including a penlight battery supplying power to the pulse repetition interval generator, fixed reference delay means, transmit pulse generator, adjustable delay means, gating pulse generator, UWB radar receiver, and signal processing means.

26. An ultra-wideband (UWB) radar motion sensor, comprising:
a pulse repetition interval generator;
a fixed reference delay means connected to the pulse repetition interval generator;
a transmit pulse generator connected to the reference delay means;
a transmit antenna connected to the transmit pulse generator;
an adjustable delay means connected to the pulse repetition interval generator;
a gating pulse generator connected to the adjustable delay means;
an UWB radar receiver connected to the gating pulse generator;
a receiver antenna connected to the UWB receiver; and
signal processing means connected to the UWB receiver;
wherein the UWB receiver includes a sampler which accumulates effects of a plurality of signals on the receiver antenna in response to a corresponding plurality of gating pulses generated by the gating pulse generator to produce a sampler signal.

27. The radar motion sensor of claim 26, wherein said effects comprise respective sums of signals on the receiver antenna and corresponding gating pulses which exceed a diode threshold.

28. The radar motion sensor of claim 26, wherein the sampler comprises a capacitor having one terminal connected to the receive antenna, a diode having a first terminal coupled to another terminal of the capacitor, and having a second terminal coupled to the gating pulse generator.

29. The radar motion sensor of claim 28, wherein the sampler comprises an analog amplifier having an input 10 coupled to the first terminal of the diode.

30. An ultra-wideband (UWB) radar motion sensor, comprising:
a pulse repetition interval generator;
a fixed reference delay means connected to the pulse repetition interval generator;
a transmit pulse generator connected to the reference delay means;
a transmit antenna connected to the transmit pulse generator;
an adjustable delay means connected to the pulse repetition interval generator;
a gating pulse generator connected to the adjustable delay means;
an UWB radar receiver connected to the gating pulse generator;
a receiver antenna connected to the UWB receiver; and
signal processing means connected to the UWB receiver;
wherein the transmit pulse generator comprises circuitry biased for operation in a non-avalanche mode which supplies a transmit pulse to the transmit antenna.
31. The radar motion sensor of claim 30, wherein the circuitry biased for operation in a non-avalanche mode comprises a step recovery diode.
32. The radar motion sensor of claim 30, wherein the circuitry biased for operation in a non-avalanche mode comprises a bipolar transistor.
33. An ultra-wideband (UWB) radar motion sensor, comprising:
a pulse repetition interval generator;
a fixed reference delay means connected to the pulse repetition interval generator;
a transmit pulse generator connected to the reference delay means;
a transmit antenna connected to the transmit pulse generator;
an adjustable delay means connected to the pulse repetition interval generator;
a gating pulse generator connected to the adjustable delay means;
an UWB radar receiver connected to the gating pulse generator;
a receiver antenna connected to the UWB receiver; and

signal processing means connected to the UWB receiver; wherein the receiver comprises an integrating sampler.

34. An ultra-wideband (UWB) radar motion sensor, comprising:
a pulse repetition interval generator;
a fixed reference delay means connected to the pulse repetition interval generator;
a transmit pulse generator connected to the reference delay means;
a transmit antenna connected to the transmit pulse generator;
an adjustable delay means connected to the pulse repetition interval generator;
a gating pulse generator connected to the adjustable delay means;
an UWB radar receiver connected to the gating pulse generator;
a receiver antenna connected to the UWB receiver; and
signal processing means connected to the UWB receiver; wherein the receiver comprises a differential integrating sampler.

35. An ultra-wideband (UWB) radar motion sensor, comprising:
a pulse repetition interval generator;
a fixed reference delay means connected to the pulse repetition interval generator;
a transmit pulse generator connected to the reference delay means;
a transmit antenna connected to the transmit pulse generator;
an adjustable delay means connected to the pulse repetition interval generator;
a gating pulse generator connected to the adjustable delay means;
an UWB radar receiver connected to the gating pulse generator;
a receiver antenna connected to the UWB receiver; and
signal processing means connected to the UWB receiver; wherein the receiver comprises an integrating sampler, and the signal processing means comprises an integrator which smooths the output of the integrating sampler, and a differentiator which differentiates the output of the integrator to obtain target motion information.

36. An ultra-wideband (UWB) radar motion sensor, comprising:

a pulse repetition interval generator;
a fixed reference delay means connected to the pulse repetition interval generator;
a transmit pulse generator connected to the reference delay means;
a transmit antenna connected to the transmit pulse generator;
an adjustable delay means connected to the pulse repetition interval generator;
a gating pulse generator connected to the adjustable delay means;
an UWB radar receiver connected to the gating pulse generator;
a receiver antenna connected to the UWB receiver; and
signal processing means connected to the UWB receiver; wherein the transmit pulse generator comprises a circuit producing antenna ring down pulses on the transmit antenna.

37. The motion detector of claim 36, wherein the UWB radar receiver comprises an integrating sampler.

38. An ultra-wideband (UWB) radar motion sensor, comprising:
a pulse repetition interval generator;
a fixed reference delay means connected to the pulse repetition interval generator;
a transmit pulse generator connected to the reference delay means;
a transmit antenna connected to the transmit pulse generator;
an adjustable delay means connected to the pulse repetition interval generator;
a gating pulse generator connected to the adjustable delay means;
an UWB radar receiver connected to the gating pulse generator;
a receiver antenna connected to the UWB receiver; and signal processing means connected to the UWB receiver; wherein UWB receiver includes resources to receive return echoes for a plurality of ranges, including a first range and a second range different than the first range.

39. The radar motion sensor of claim 38, wherein the signal processing means determines target velocity in response to the received return echoes for the first and second ranges.
40. The radar motion sensor of claim 38, wherein the UWB receiver comprises an integrating sampler, and resources to time multiplex use of the integrating sampler for the first and second range.
41. The radar motion sensor of claim 38, wherein the UWB receiver comprises a plurality of integrating samplers for the plurality of ranges respectively.
42. The radar motion sensor of claim 38, wherein the UWB receiver comprises a first integrating sampler and second integrating sampler, and a circuit to delay arrival of gating pulses from the gate pulse generator to the second integrating sampler relative to arrival of gating pulses from the gate pulse generator to the first integrating sampler.
43. The radar motion sensor of claim 38, wherein the UWB receiver comprises a first integrating sampler and second integrating sampler, and a circuit to delay arrival of signals from the receive antenna to the second integrating sampler relative to arrival of signals from the receive antenna to the first integrating sampler.
44. The radar motion sensor of claim 38, wherein the transmit pulse generator comprises a circuit producing antenna ringdown pulses on the transmit antenna.
45. An ultra-wideband (UWB) radar motion sensor, comprising:
a pulse repetition interval generator;
a fixed reference delay means connected to the pulse repetition interval generator;
a transmit pulse generator connected to the reference delay means;
a transmit antenna connected to the transmit pulse generator;
an adjustable delay means connected to the pulse repetition interval generator;

a gating pulse generator connected to the adjustable delay means;
 an UWB radar receiver connected to the gating pulse generator;
 a receiver antenna connected to the UWB receiver; and signal processing means connected to the UWB receiver; wherein the receiver comprises an input node coupled to the receive antenna, a diode having an anode and a cathode, the anode coupled to the input node, and the cathode coupled to the gating pulse generator, a capacitive node coupled to the anode of the diode at which effects of a plurality of pulses accumulate.

46. An ultra-wideband (UWB) radar motion sensor, comprising:

a pulse repetition interval generator;

a fixed reference delay means connected to the pulse repetition interval generator;

a transmit pulse generator connected to the reference delay means;

a transmit antenna connected to the transmit pulse generator;

an adjustable delay means connected to the pulse repetition interval generator;

a gating pulse generator connected to the adjustable delay means;

an UWB radar receiver connected to the gating pulse generator;

a receiver antenna connected to the UWB receiver; and

signal processing means connected to the UWB receiver; wherein the receiver comprises:

an first input node coupled to the receive antenna, a first diode having an anode and a cathode, the anode coupled to the first input node, and the cathode coupled to the gating pulse generator, a first capacitive node coupled to the anode of the diode at which a first signal reflecting effects of a plurality of pulses accumulate;
 an second input node coupled to the receive antenna, a second diode having an anode coupled to the second input node and a cathode coupled to the gating pulse generator, a second capacitive node coupled to the anode of the second diode at which a second signal reflecting effects of a plurality of pulses accumulate; and

a circuit to combine the first signal and the second signal produce a receiver output.

47. An ultra-wideband (UWB) radar motion sensor, comprising:
a pulse repetition interval generator;
a fixed reference delay means connected to the pulse repetition interval generator;
a transmit pulse generator connected to the reference delay means;
a transmit antenna connected to the transmit pulse generator;
an adjustable delay means connected to the pulse repetition interval generator;
a gating pulse generator connected to the adjustable delay means;
an UWB radar receiver connected to the gating pulse generator;
a receiver antenna connected to the UWB receiver; and signal processing means connected to the UWB receiver; wherein the pulse repetition interval generator, fixed reference delay means, transmit pulse generator, adjustable delay means, gating pulse generator, UWB radar receiver, and signal processing means comprise elements on a single integrated circuit.
48. The radar motion sensor of claim 47, wherein the integrated circuit comprises a silicon integrated circuit.
49. An ultra-wideband (UWB) radar motion sensor, comprising:
a pulse repetition interval generator;
a fixed reference delay means connected to the pulse repetition interval generator;
a transformerless transmit pulse generator connected to the reference delay means;
a transmit antenna connected to the transmit pulse generator;
an adjustable delay means connected to the pulse repetition interval generator;
a gating pulse generator connected to the adjustable delay means;
an inductor less UWB radar receiver connected to the gating pulse generator;
a receiver antenna connected to the UWB receiver; and signal processing means connected to the UWB receiver.
50. An ultra-wideband (UWB) radar sensor, comprising:

a pulse repetition interval generator;
a fixed reference delay means connected to the pulse repetition interval generator;
a transmit pulse generator connected to the reference delay means;
a transmit antenna connected to the transmit pulse generator;
an adjustable delay means connected to the pulse repetition interval generator;
a receiver antenna;
a gating pulse generator connected to the adjustable delay means ;
an UWB radar receiver connected to the gating pulse generator and to the receiver antenna, said UWB radar receiver detecting reflected UWB radar pulses from a predetermined range and producing a detection output signal indicative of a plurality of said pulses, said UWB radar receiver comprising means for integrating said reflected UWB radar pulses, said detection output signal corresponding to an average of said plurality of said reflected pulses; and
signal processing means for processing said detection output signal, said signal processing means being connected to the UWB receiver and comprising integrating means producing an average output signal corresponding to a further average of said plurality of said reflected pulses, said sensor being such as to sense motion.

51. The sensor of claim 50 further comprising alarm means connected to the signal processing means.

52. The sensor of claim 50 or 51, further comprising a noise generator connected to the pulse repetition interval generator.

53. The sensor of any one of claims 50 to 52, further comprising range adjustment means connected to the adjustable delay means.

54. The sensor of any one of claims 50 to 53, wherein the signal processing means comprises an integrator and a differentiator.

55. The sensor of any one of claims 50 to 54, wherein the signal processing means is a bandpass filter.

56. The sensor of any one of claims 50 to 55, wherein the pulse repetition interval generator is a dithered pulse generator.

57. The sensor of any one of claims 50 to 56, comprising a square wave oscillator connected to the adjustable delay means for repetitively switching between two fixed ranges and an analog switch connected to the output of the UWB receiver and to the square wave oscillator for switching the UWB receiver output to separate motion detectors for each range.

58. The sensor of any one of claims 50 to 57, comprising a second UWB radar receiver connected to the gating impulse generators, a second receiver antenna connected to the second UWB receiver, and a delay line positioned either between the second receiver antenna and the second UWB receiver, or in-between the gating impulse generator and one of the UWB receivers .

59. The sensor of any one of claims 50 to 58, further including means for averaging about 1,000 to 10,000 pulses.

60. The sensor of any one of claims 50 to 59, wherein the transmit and receiver antennas are formed of a dipole pair which exhibits antenna ringdown.

61. The sensor of any one of claims 50 to 60, further wherein the transmit pulse generator comprises a shock excited turned circuit or bandpass filter.

62. The sensor of any one of claims 50 to 61, wherein the transmit pulse generator comprises a modulated oscillator.

63. The sensor of any one of claims 50 to 62, wherein the transmit antenna and the receiver antenna comprise a shared element.

64. The sensor of claim 63, wherein the UWB receiver includes a sampler which accumulates effects of a plurality of signals on the receiver antenna in response to a corresponding plurality of gating pulses generated by the gating pulse generator to produce a sampler signal.

65. The sensor of claim 64, wherein said effects comprise respective sums of signals on the receiver antenna and corresponding gating pulses which exceed a diode threshold.

66. The sensor of claim 64, wherein the sampler comprises a capacitor having one terminal connected to the receiver antenna, a diode having a first terminal coupled to another terminal of the capacitor, and having a second terminal coupled to the gating pulse generator.

67. The sensor of claim 66, wherein the sampler comprises an analog amplifier having an input coupled to the first terminal of the diode.

68. The sensor of claims 66 or 67, wherein the capacitor has a value of $0.01 \mu\text{F}$ and the pulse repetition interval from the pulse repetition generator is $1 \mu\text{s}$.

69. The sensor of claim 68, wherein the capacitor has a value of 22 pF .

70. The sensor of any one of claims 50 to 69, wherein the UWB radar receiver comprises an integrating sampler.

71. The sensor of any one of claims 50 to 70, wherein the UWB radar receiver comprises a differential integrating sampler.

72. The sensor of any one of claims 50 to 71, wherein the UWB radar receiver comprises an integrating sampler, and the signal processing means comprises and

integrator which smooths the output of the integrating sampler, and a differentiator which differentiates the output of the integrator to obtain target motion information.

73. The sensor of any one of claims 50 to 72, wherein the transmit pulse generator comprises circuit producing antenna ringdown pulses on the transmit antenna.

74. The sensor of claim 73, wherein the UWB radar receiver comprises an integrating sampler.

75. The sensor of any one of claims 50 to 74, wherein the UWB radar receiver includes resources to receive return echoes for a plurality of ranges, including a first range and a second range different than the first range.

76. The sensor of claim 75, wherein the signal processing means determines target velocity in response to the received return echoes for the first and second ranges.

77. The sensor of claim 75, wherein the UWB receiver comprises an integrating sampler, and resources to time multiplex use of the integrating sampler for the first and second range.

78. The sensor of claim 75, wherein the UWB receiver comprises a plurality of integrating samplers for the plurality of ranges respectively.

79. The sensor of claim 75, wherein the UWB receiver comprises a first integrating sampler and second integrating sampler, and a circuit to delay arrival of gating pulses from the gate pulse generator to the second integrating sampler relative to arrival of gating pulses from the gate pulse generator to the first integrating sampler.

80. The sensor of claim 75, wherein the UWB receiver comprises a first integrating sampler and second integrating sampler, and a circuit to delay arrival of

signals from the receive antenna to the second integrating sampler relative to arrival of signals from the receive antenna to the first integrating sampler.

81. The sensor of claim 75, wherein the transmit pulse generator comprises a circuit producing antenna ringdown pulses on the transmit antenna.

82. The sensor of any one of claims 50 to 81, wherein the UWB radar receiver comprises an input node to the receive antenna, a diode having an anode and a cathode, the anode coupled to the input node, and the cathode coupled to the gating pulse generator, a capacitive node coupled to the anode of the diode at which effects of a plurality of pulses accumulate.

83. The sensor of any one of claims 50 to 82, wherein the UWB radar receiver comprises:

a first input node coupled to the receive antenna, a first diode having an anode and a cathode, the anode coupled to the first input node, and the cathode coupled to the gating pulse generator, a first capacitive node coupled to the anode of the diode at which a first signal reflecting effects of a plurality of pulses accumulate;

a second input node coupled to the receive antenna, a second diode having an anode coupled to the second input node and a cathode coupled to the gating pulse generator, a second capacitive node coupled to the anode of the second diode at which a second signal reflecting effects of a plurality of pulses accumulate; and

a circuit to combine the first signal and the second signal to produce a receiver output (UWB out).

84. The sensor of any one of claims 50 to 83, wherein the pulse repetition interval generator, fixed reference delay means, transmit pulse generator, adjustable delay means gating pulse generator, UWB radar receiver, and signal processing means comprise elements on a single integrated circuit.

85. The sensor of claim 84, wherein the integrated circuit comprises silicon integrated circuit.

86. The sensor of any one of claims 50 to 85, wherein the signal processing means connected to the UWB receiver is for processing integrated, non pulsed signals from the UWB receiver.

87. An ultra-wideband (UWB) radar sensor, comprising:

a pulse repetition interval generator;

a fixed reference delay means connected to the pulse repetition interval generator;

a transmit pulse generator connected to the reference delay means;

a transmit antenna connected to the transmit pulse generator;

an adjustable delay means connected to the pulse repetition interval generator;

a receiver antenna;

a gating pulse generator connected to the adjustable delay means ;

an UWB radar receiver connected to the gating pulse generator and to the receiver antenna, said UWB radar receiver detecting reflected UWB radar pulses from a predetermined range and producing a detection output signal, said UWB radar receiver comprising means for holding a plurality of said reflected UWB radar pulses over a sampling period; and

signal processing means for processing said detection output signal, said signal processing means being connected to the UWB receiver and comprising integrating means producing an average output signal corresponding to an average of said plurality of said reflected pulses, said sensor being such as to sense motion.

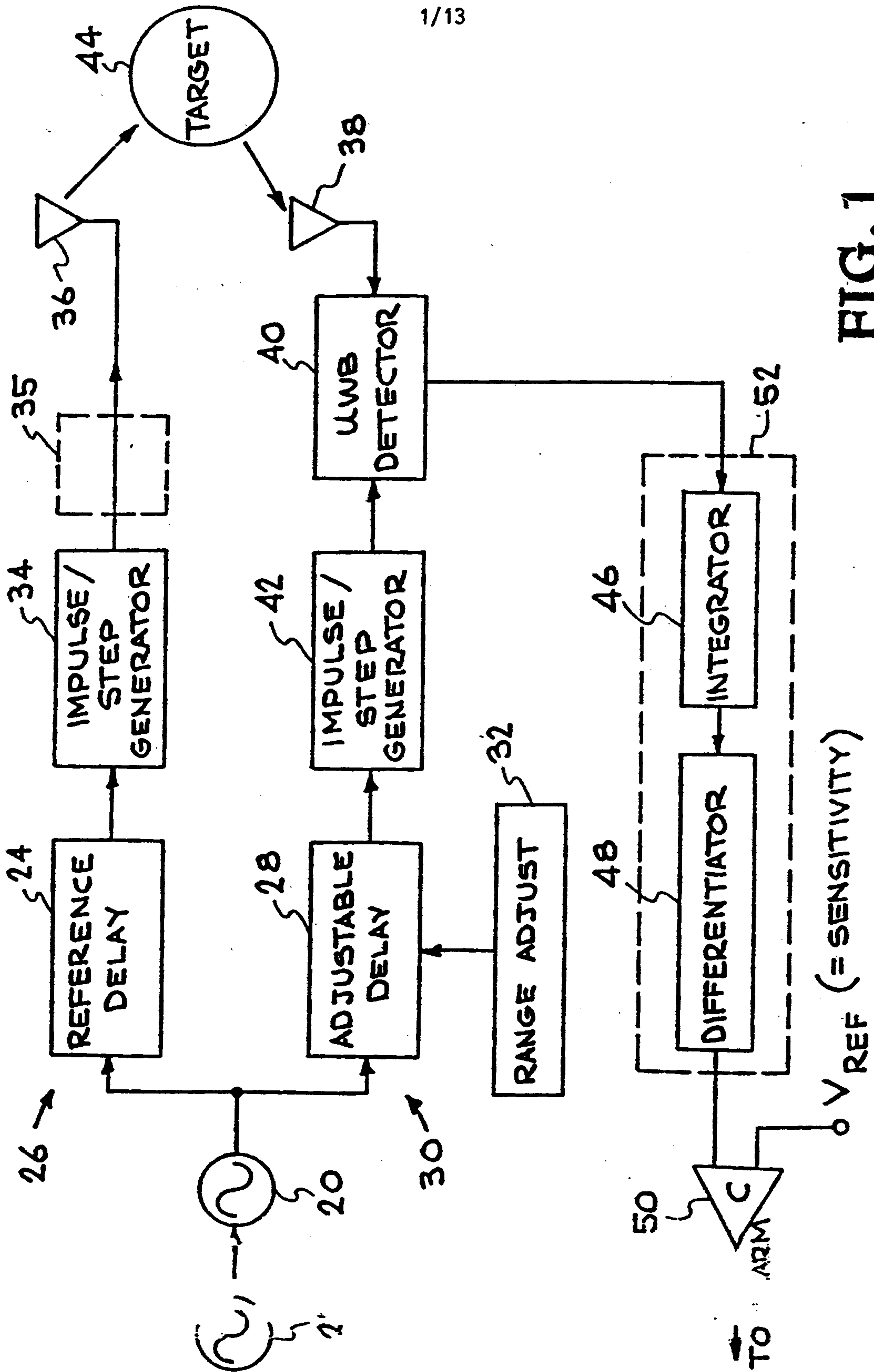

FIG. 1

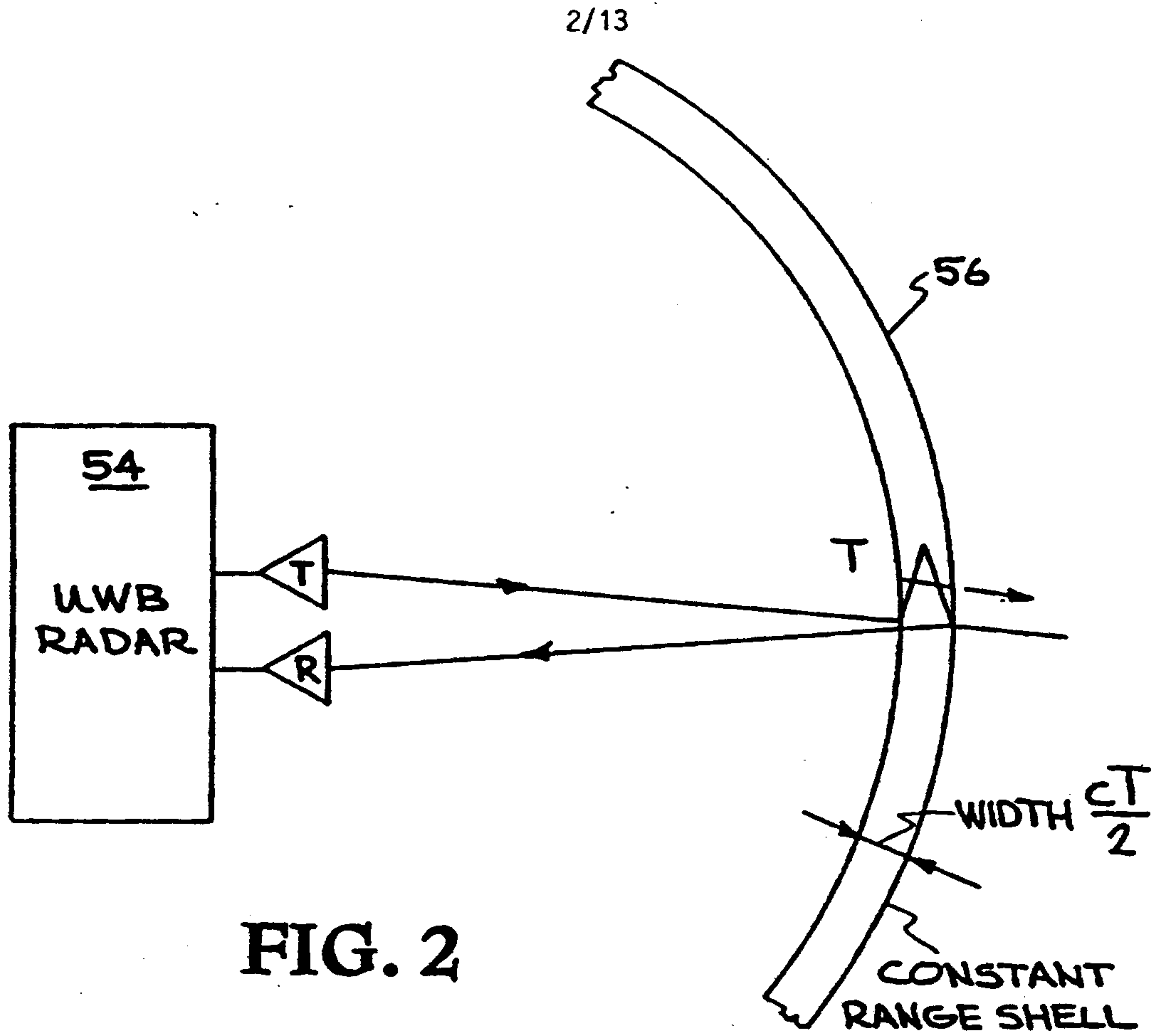

FIG. 2

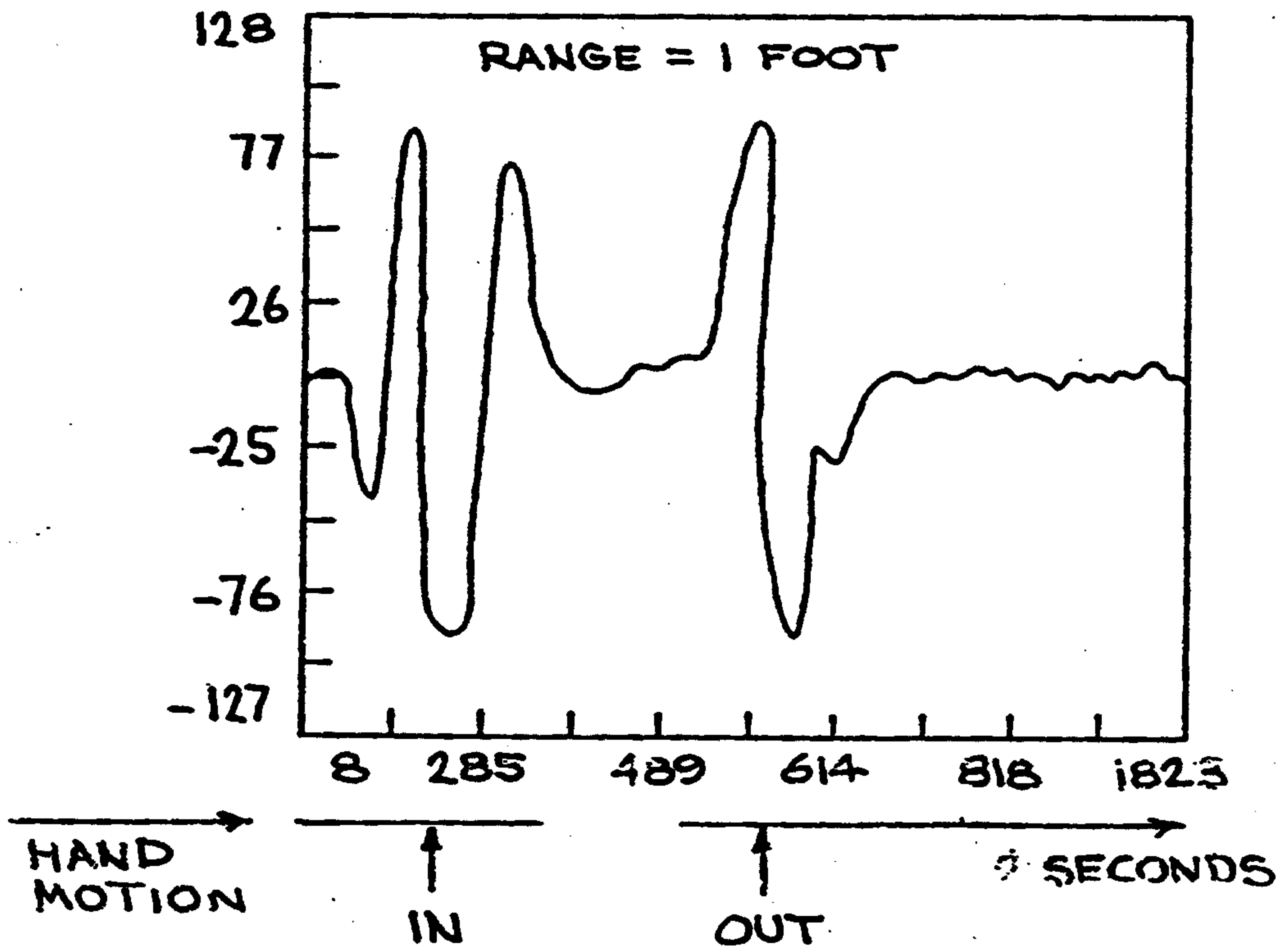

FIG. 3A

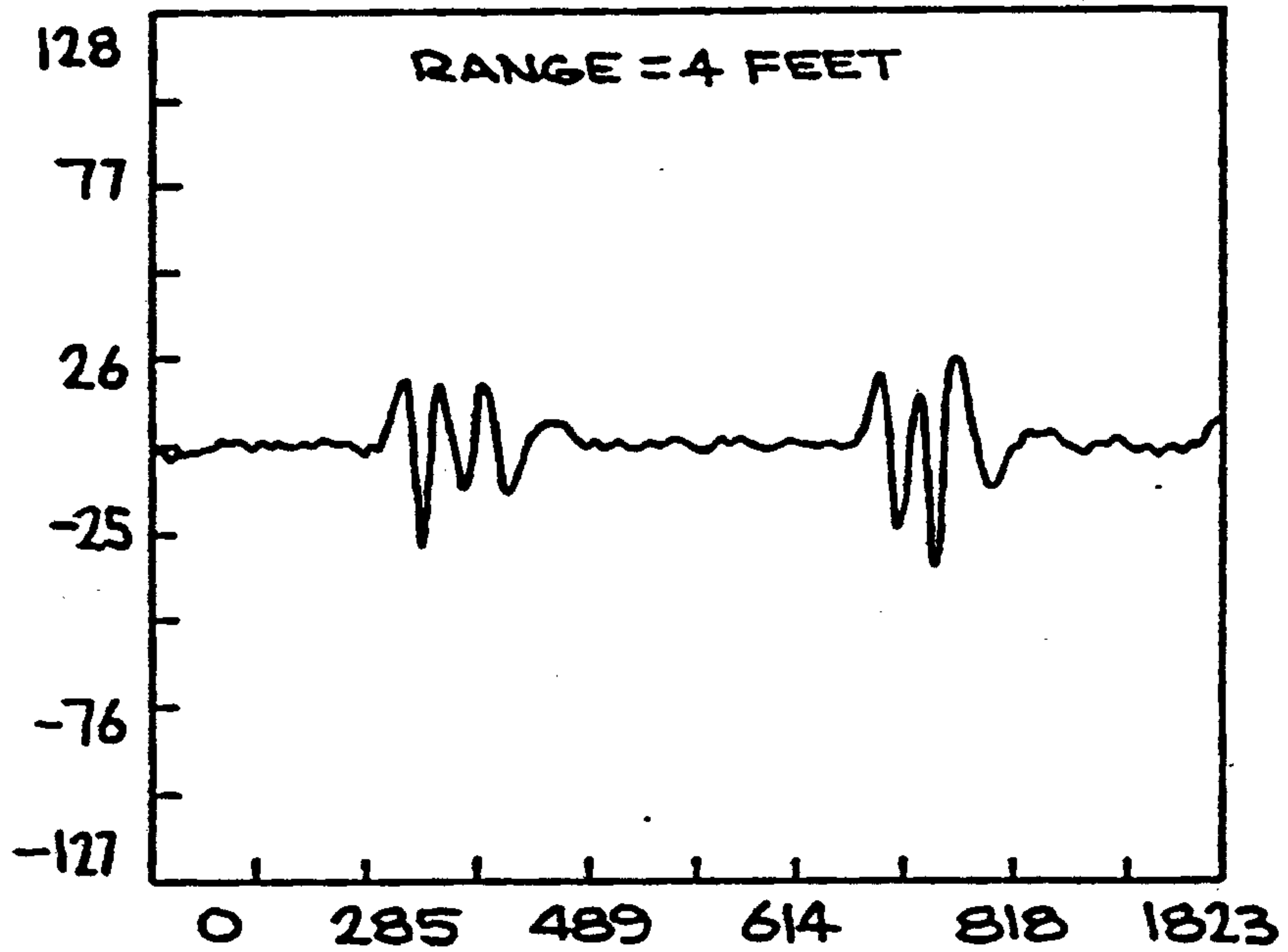

FIG. 3B

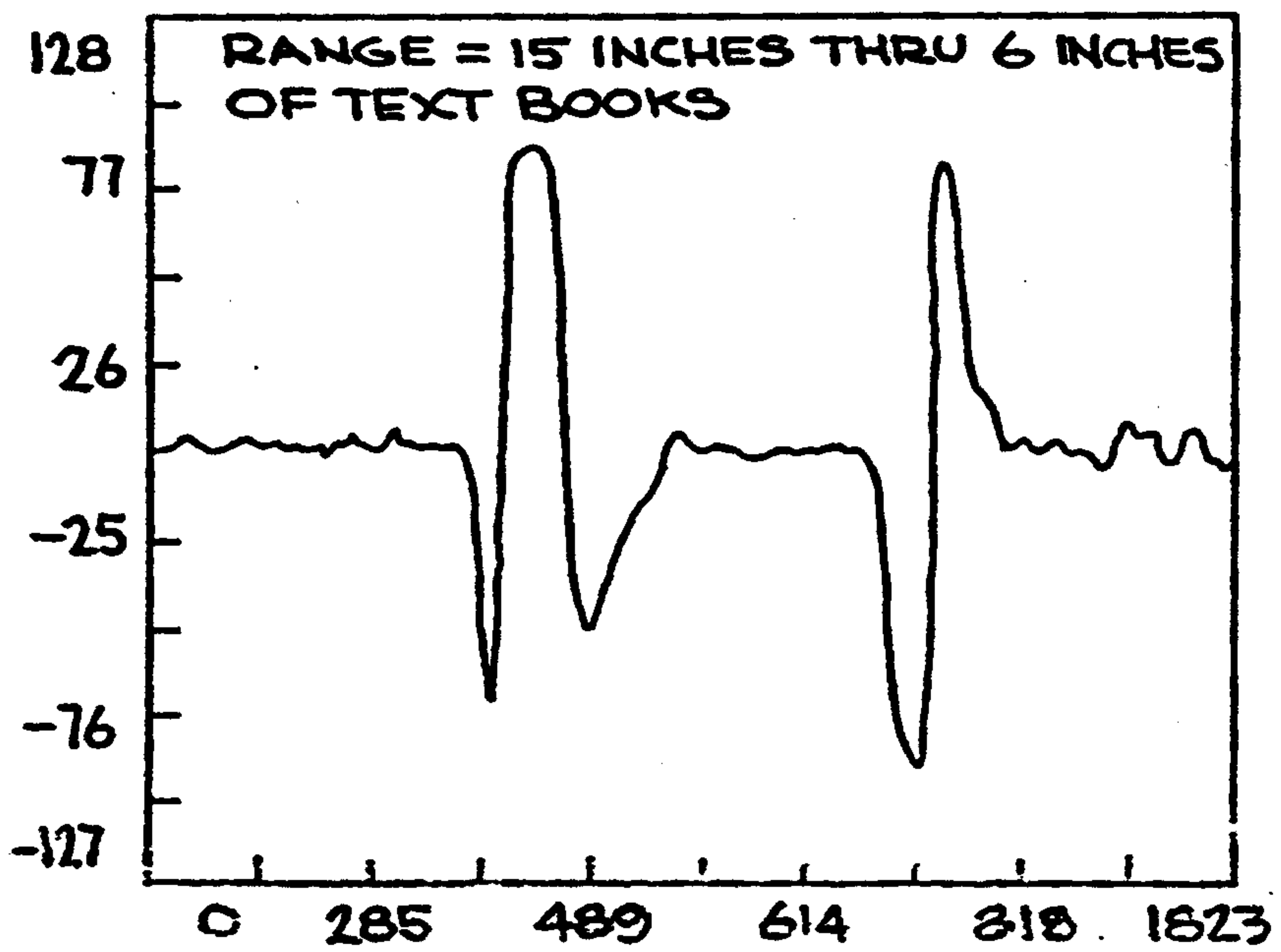

FIG. 3C

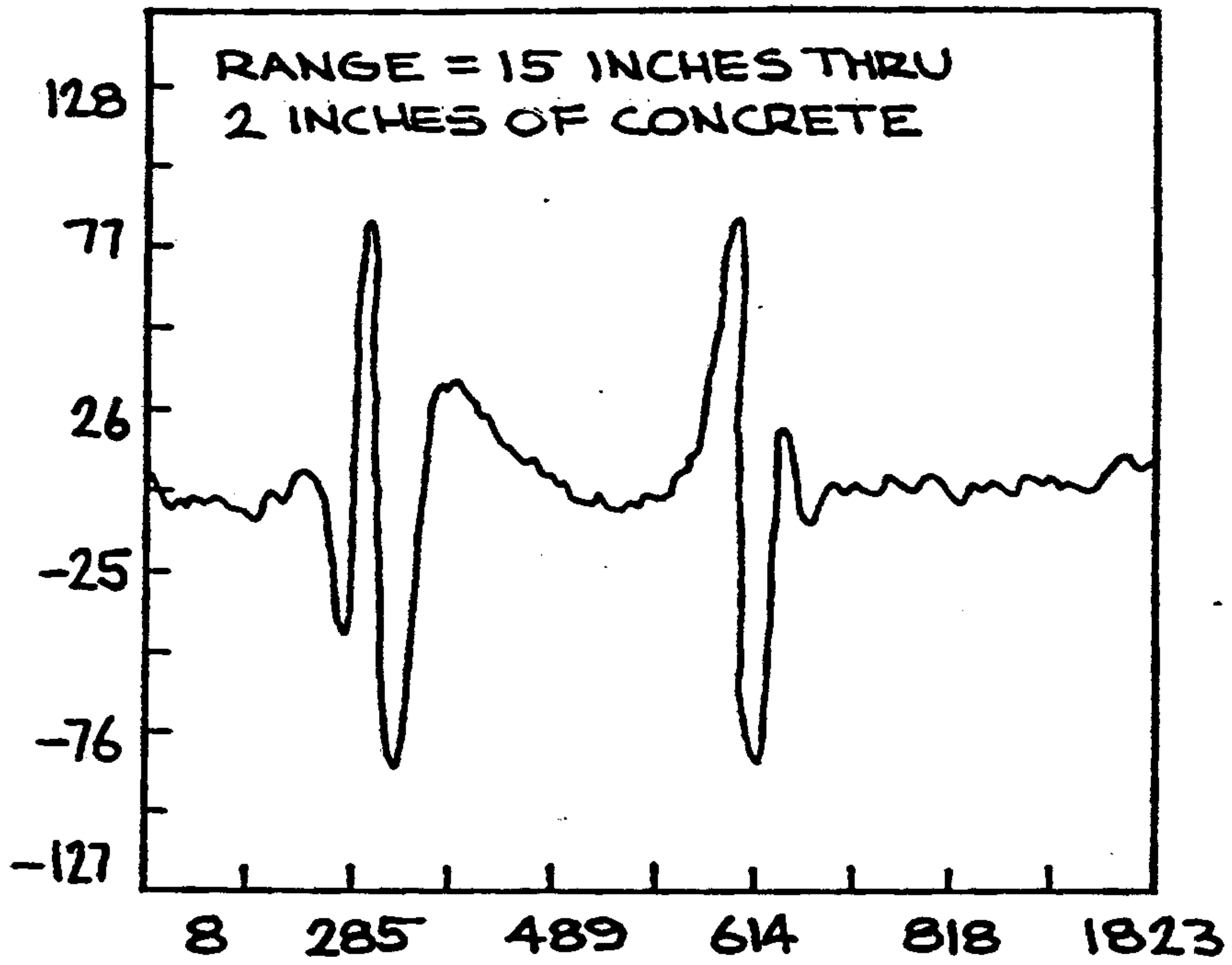

FIG. 3D

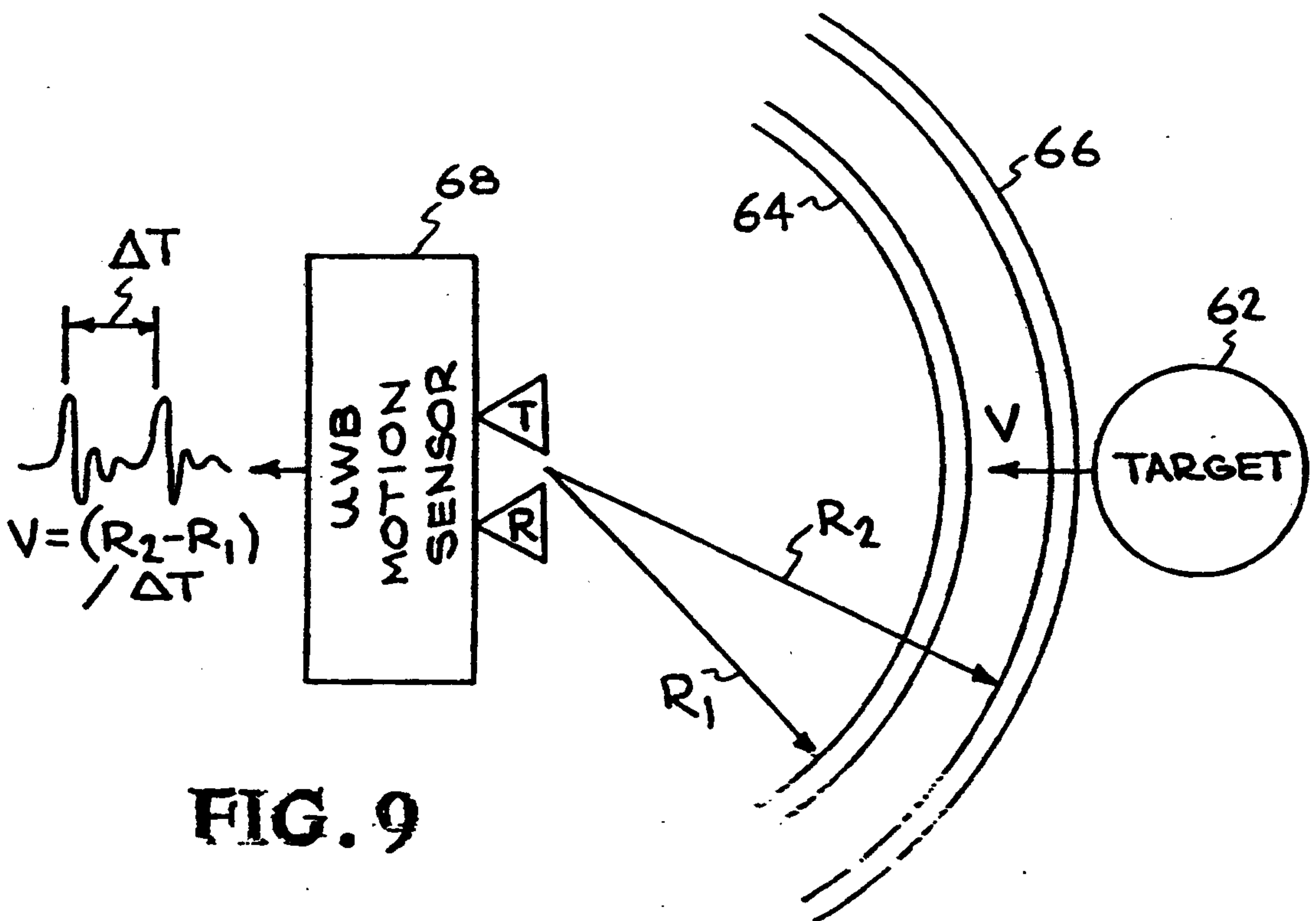

FIG. 9

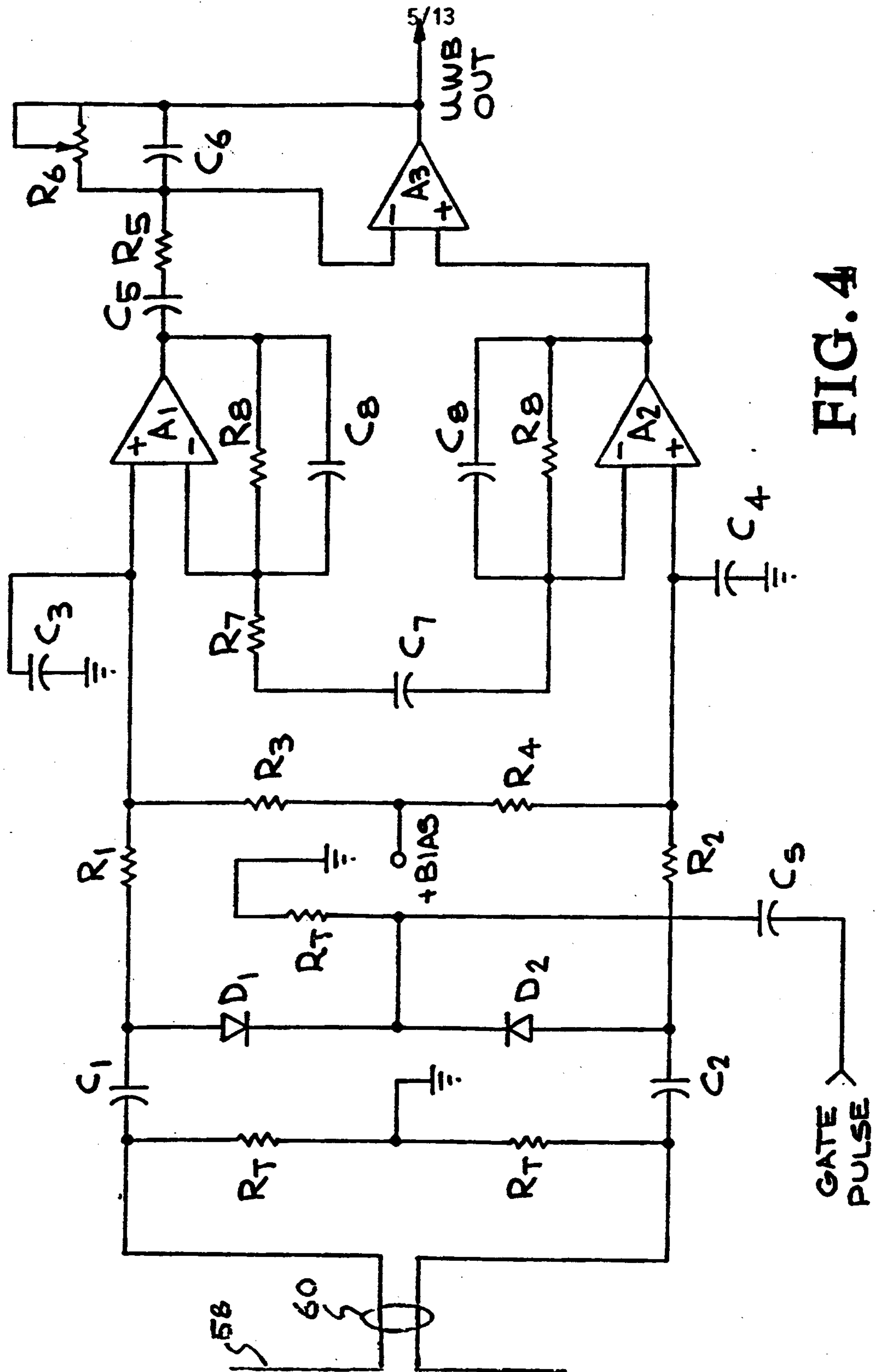

FIG. 4

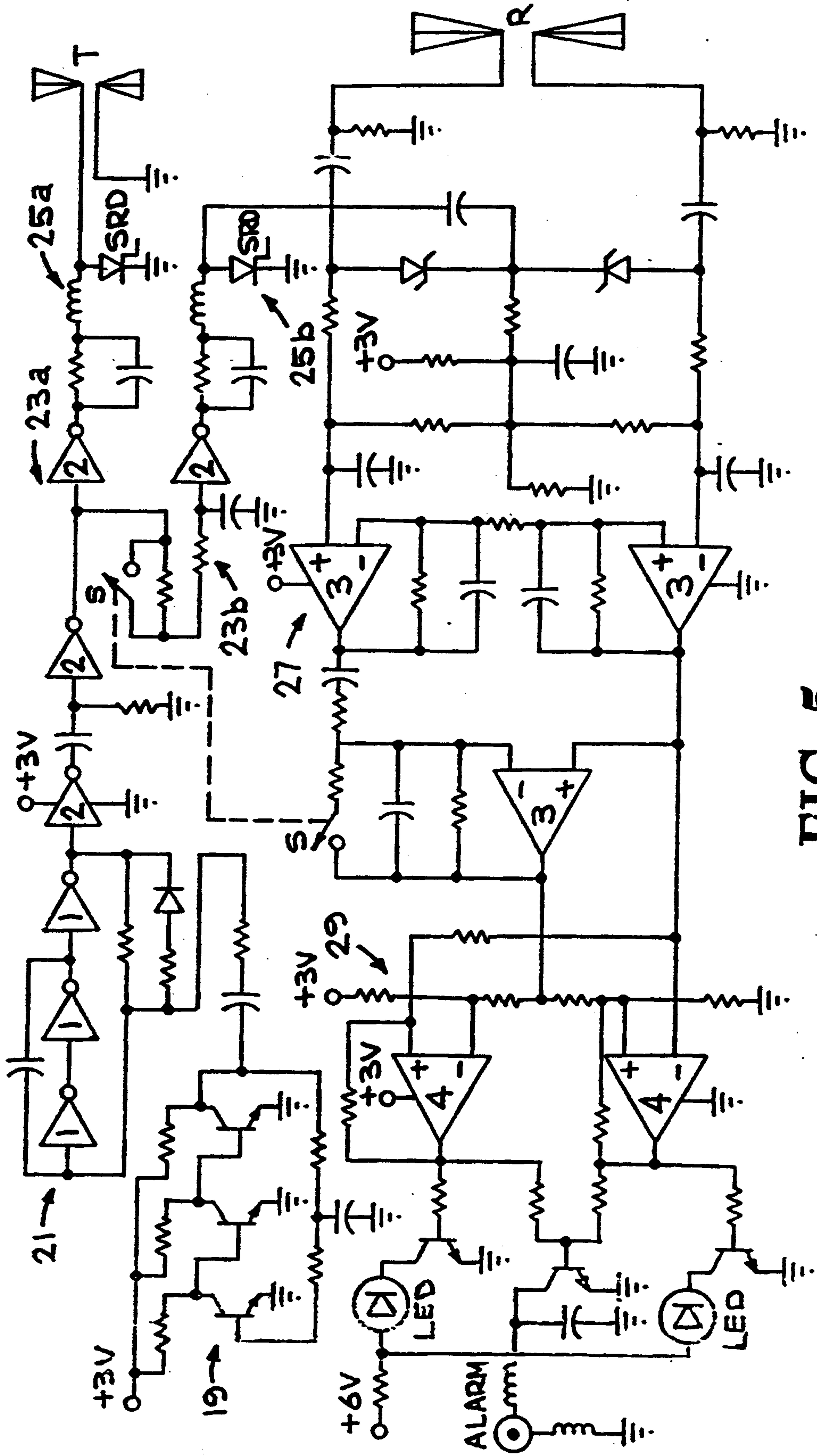

FIG. 5

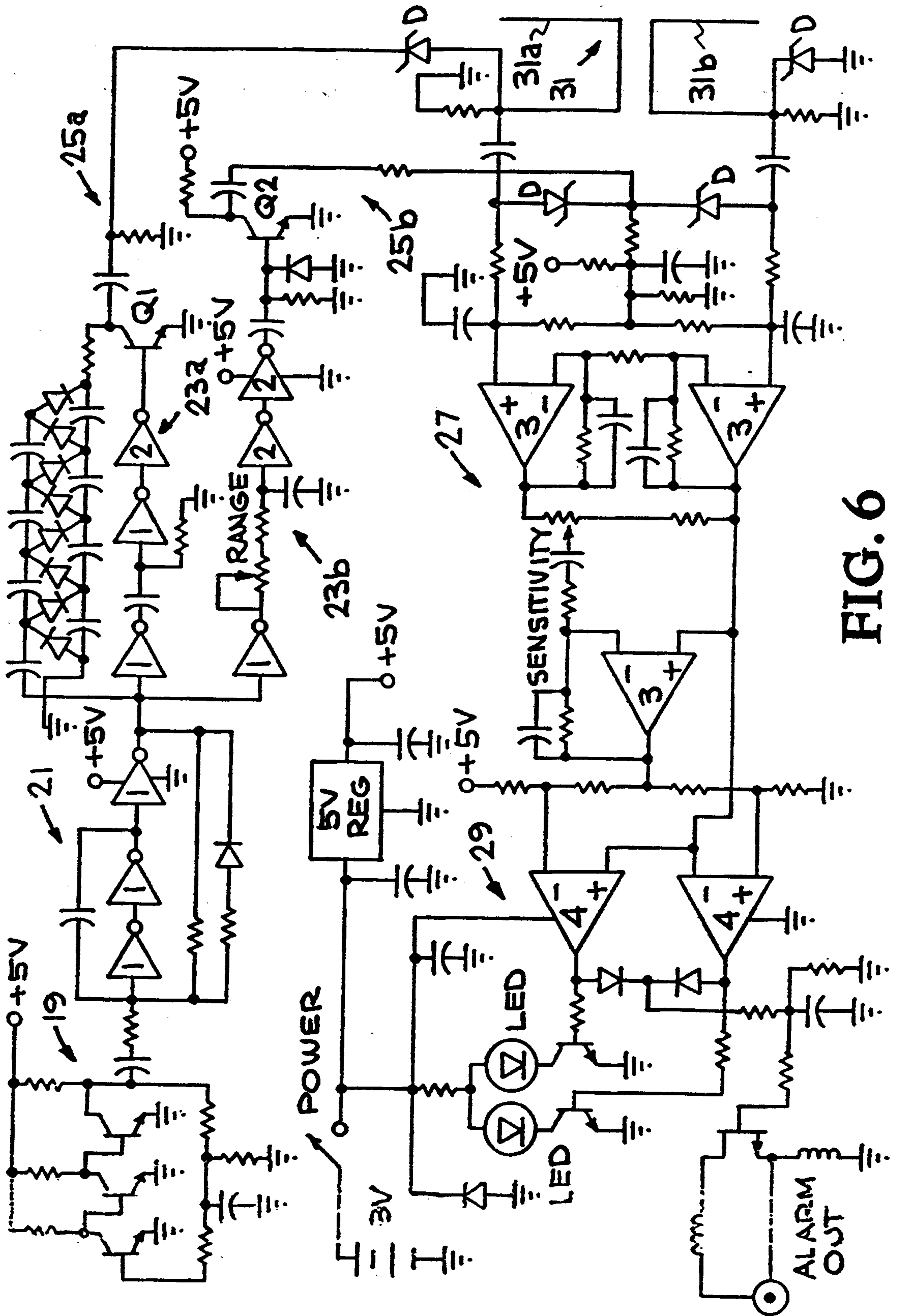

FIG. 6

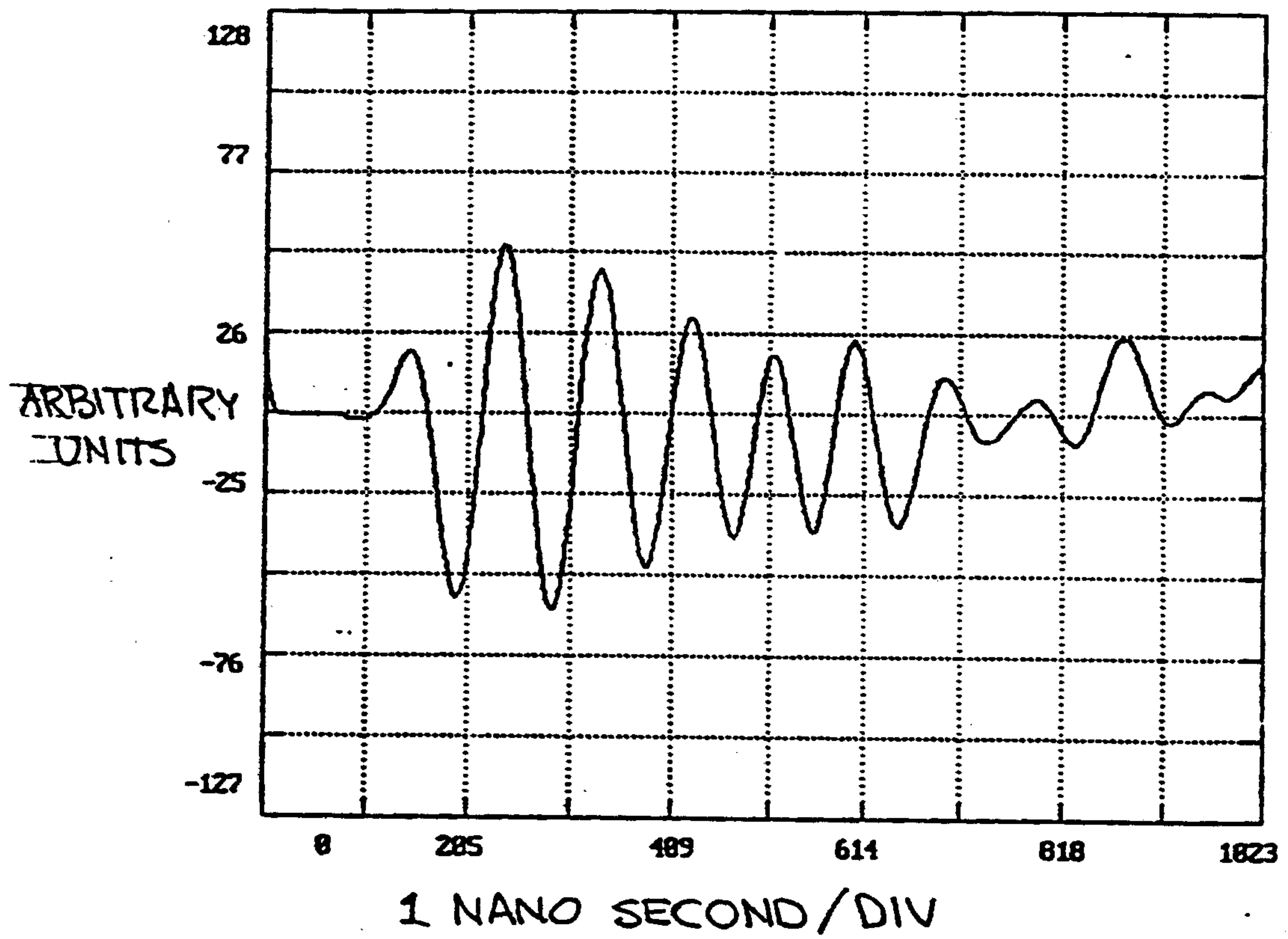
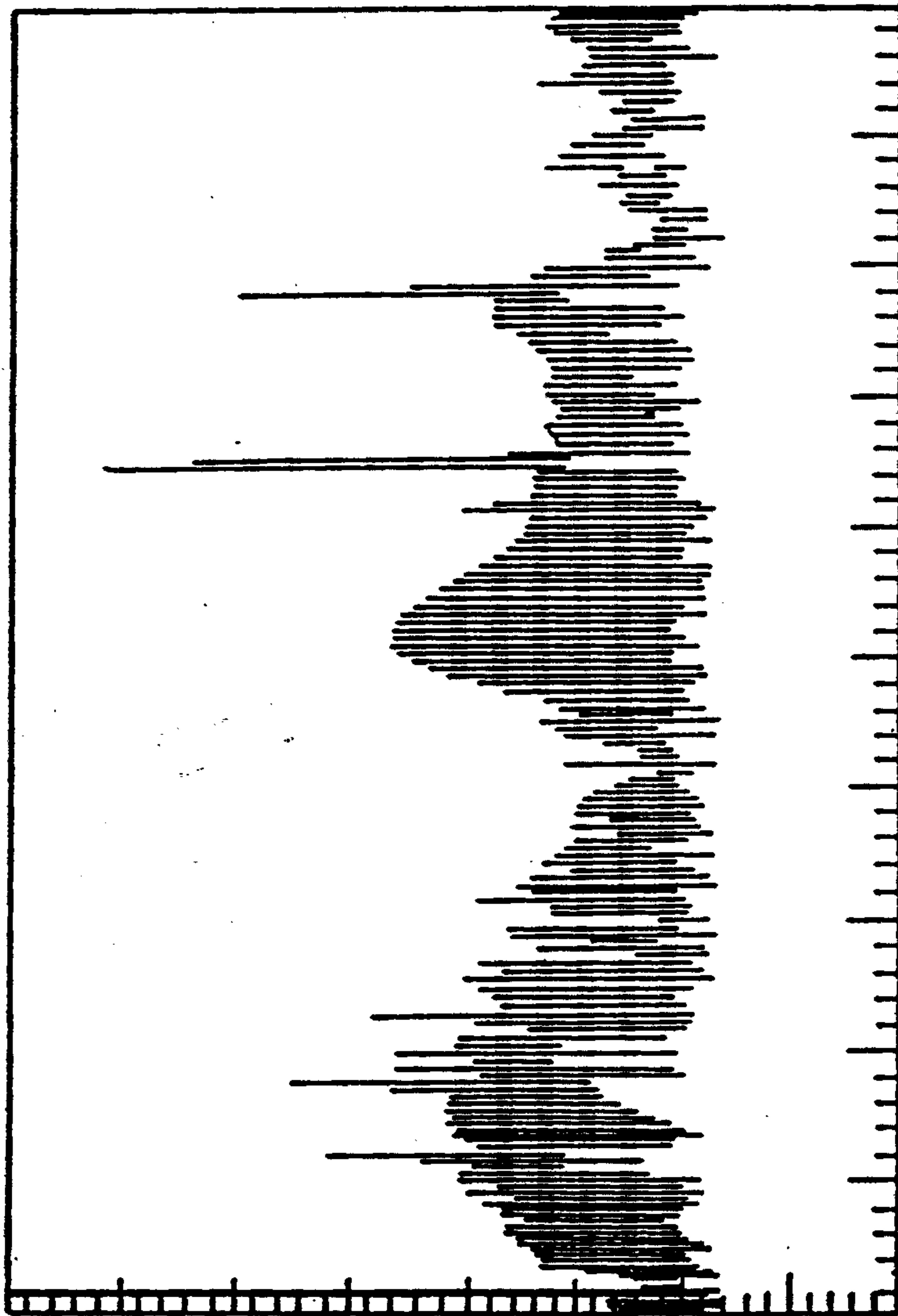

FIG. 7



10 DB / DIV.

100 MHZ / DIV.

FIG. 8A

10/13

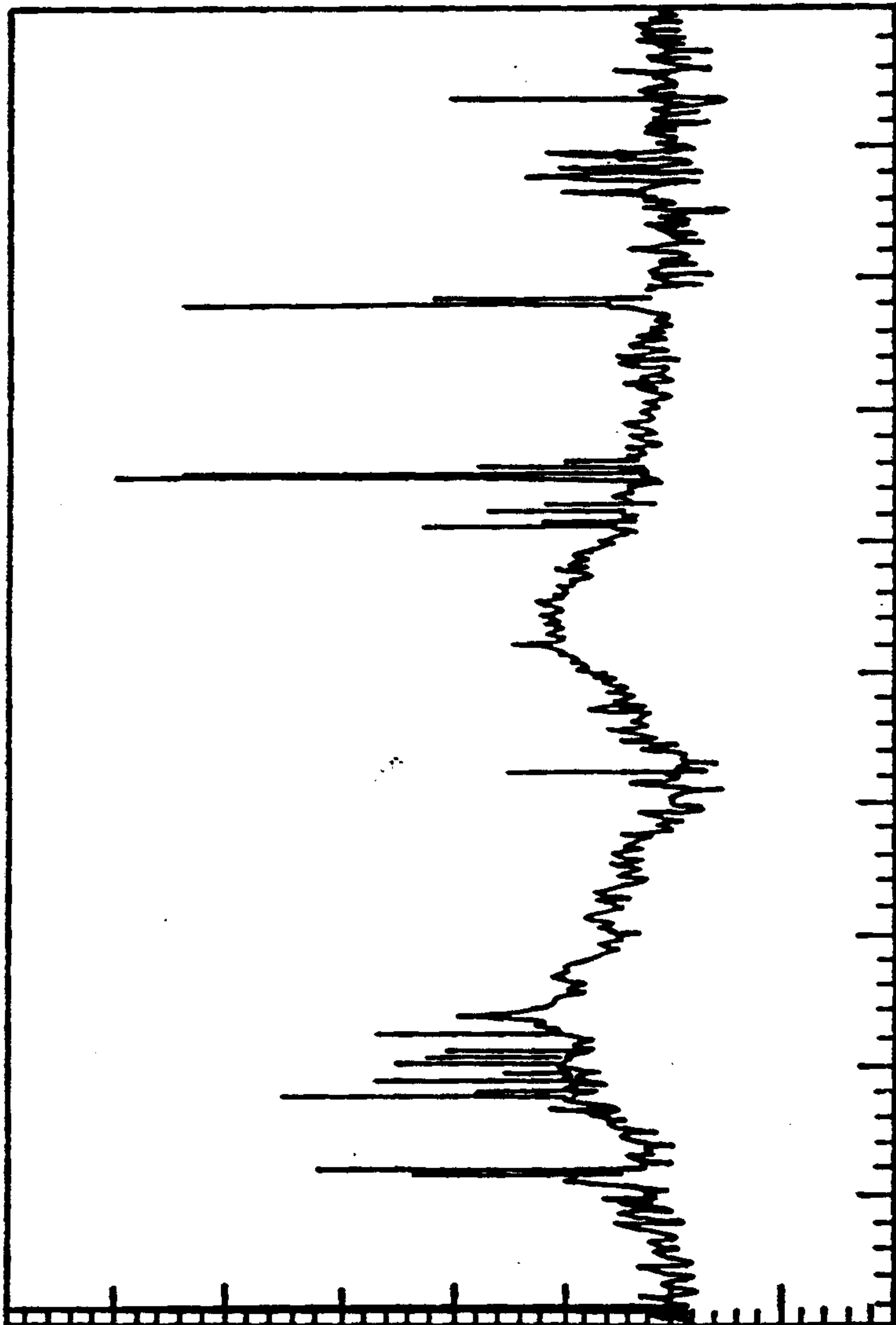

10 DB / DIV.

100 MHZ / DIV.

FIG. 8B

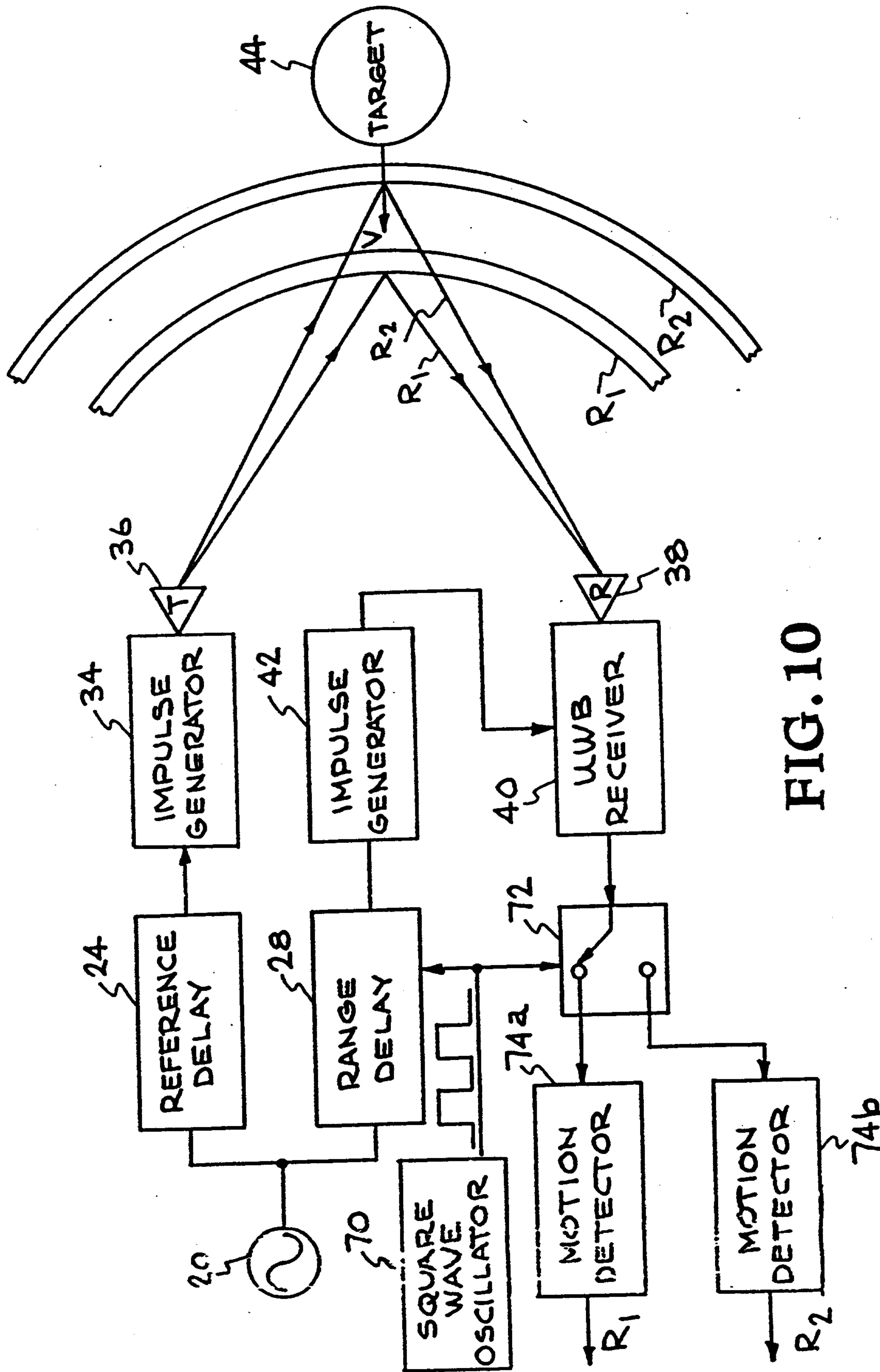

FIG. 10

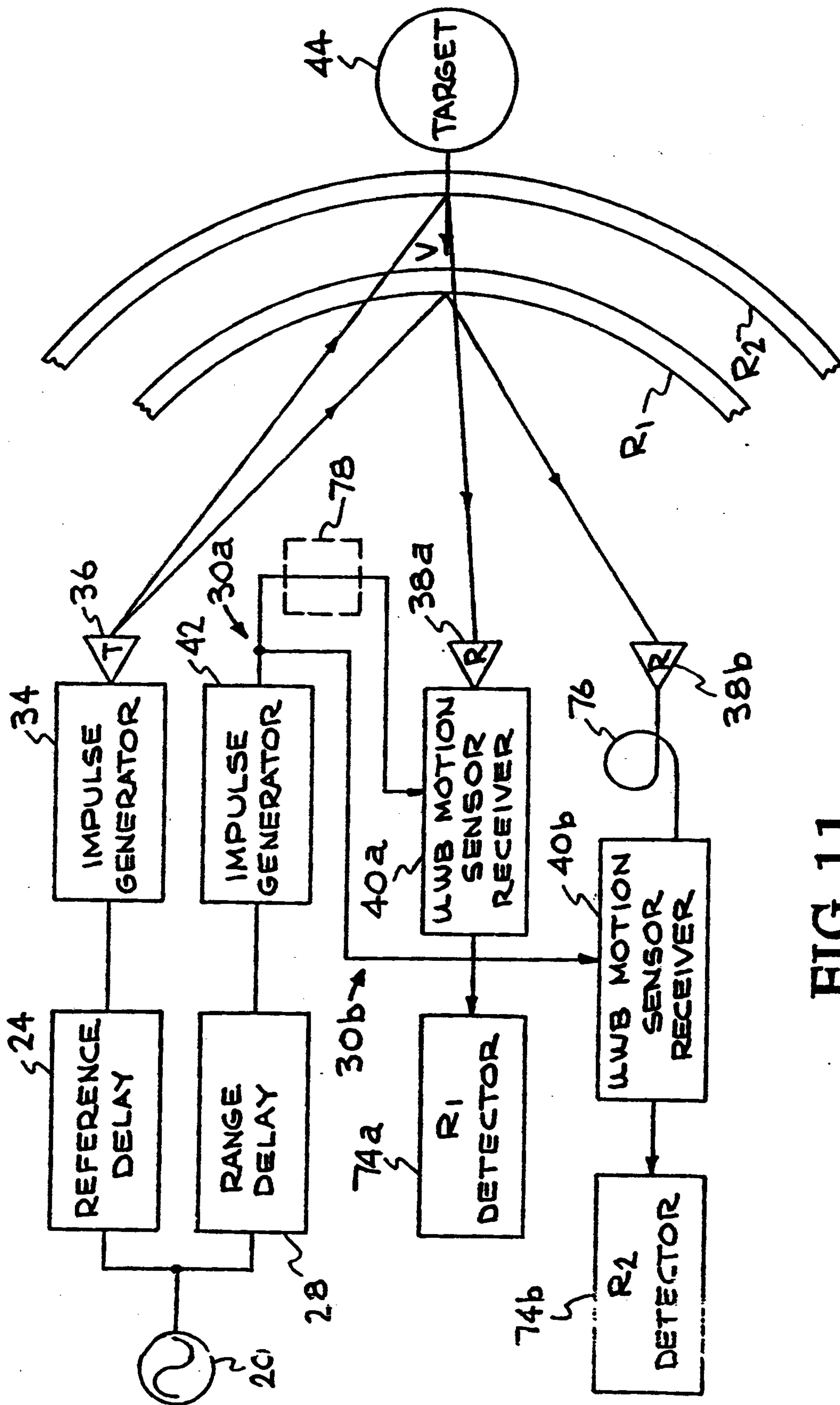

FIG. 11

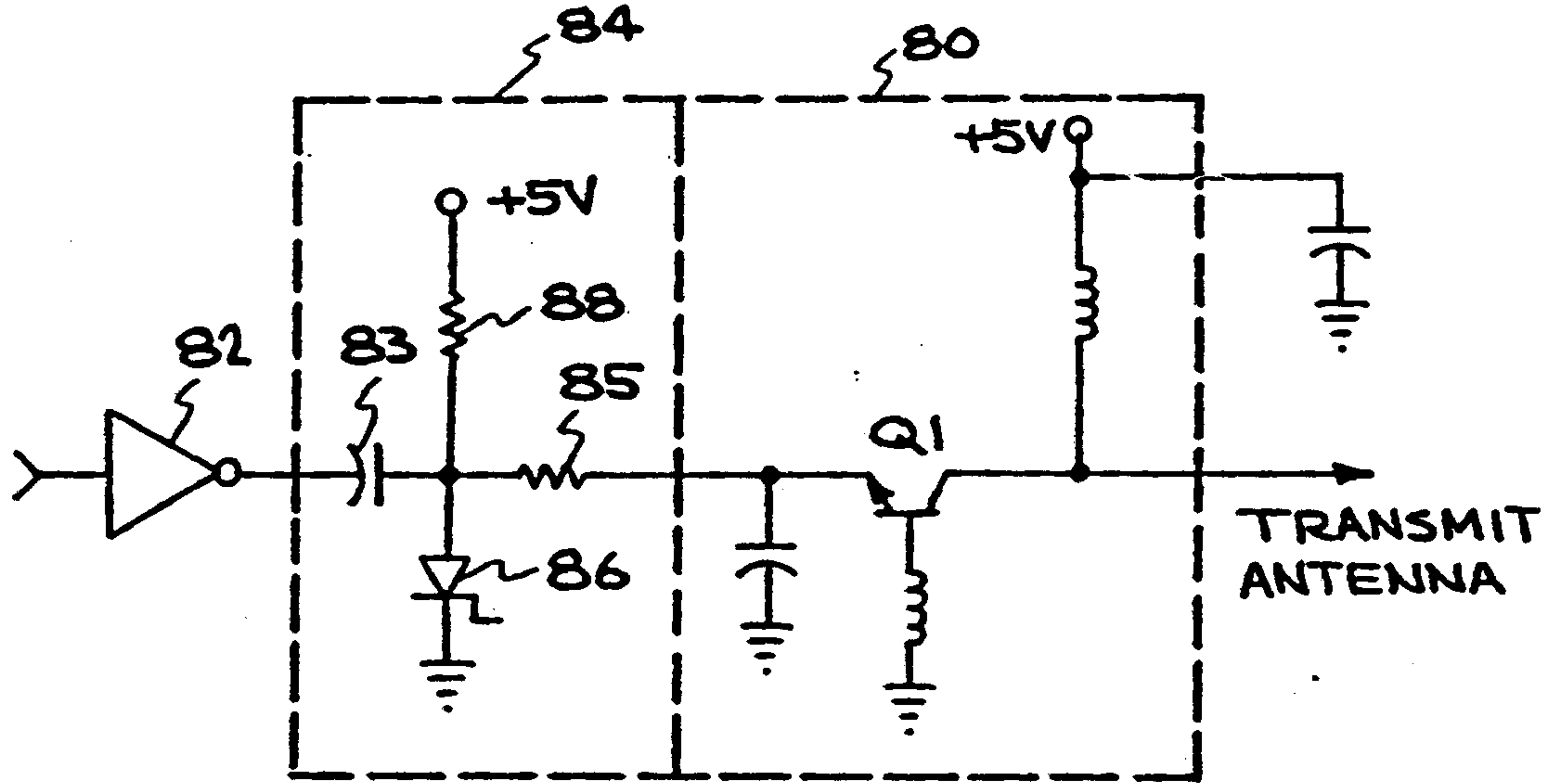
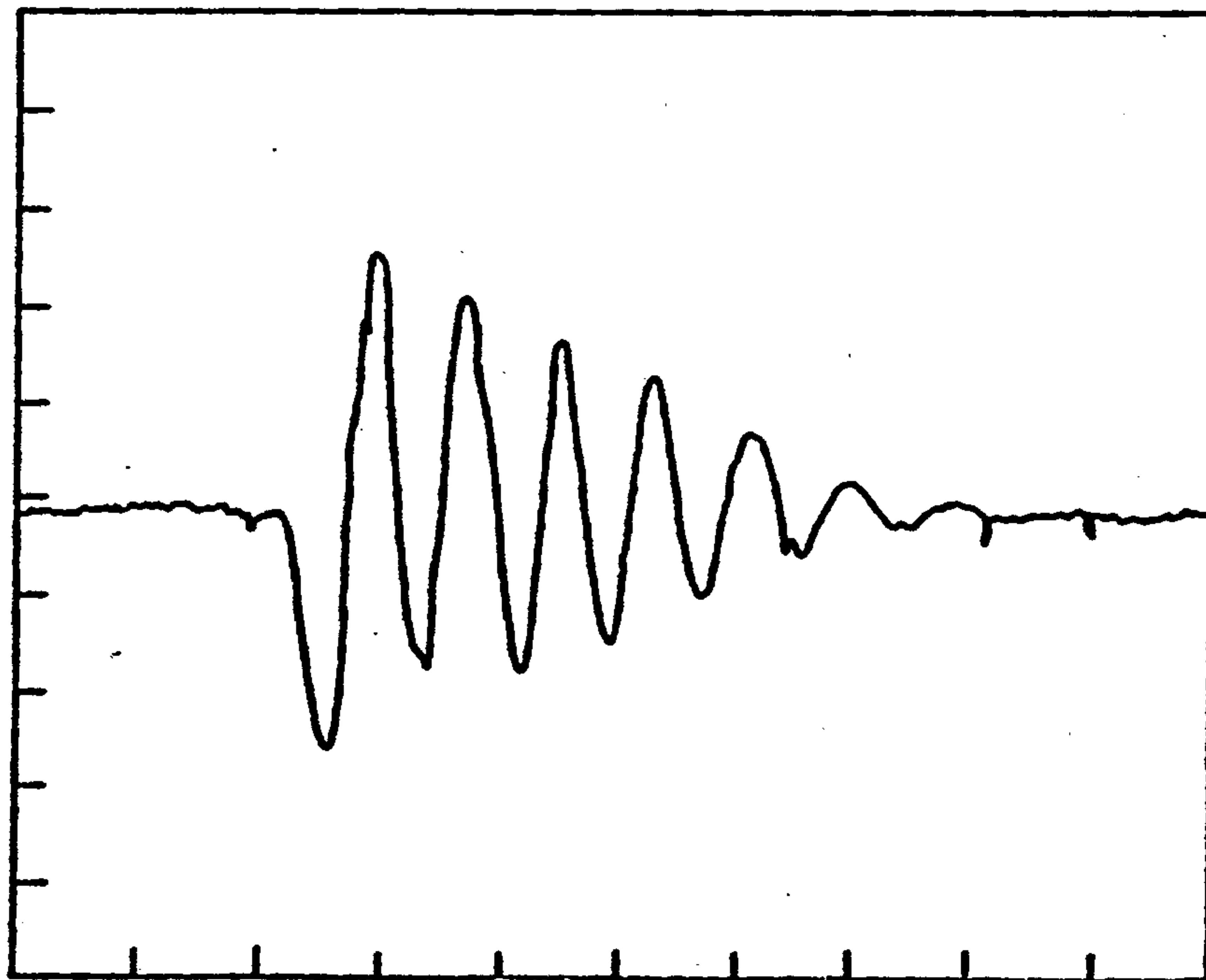

FIG. 12A



500 μ S / DIV 1.0 VOLT / DIV

FIG. 12B

