

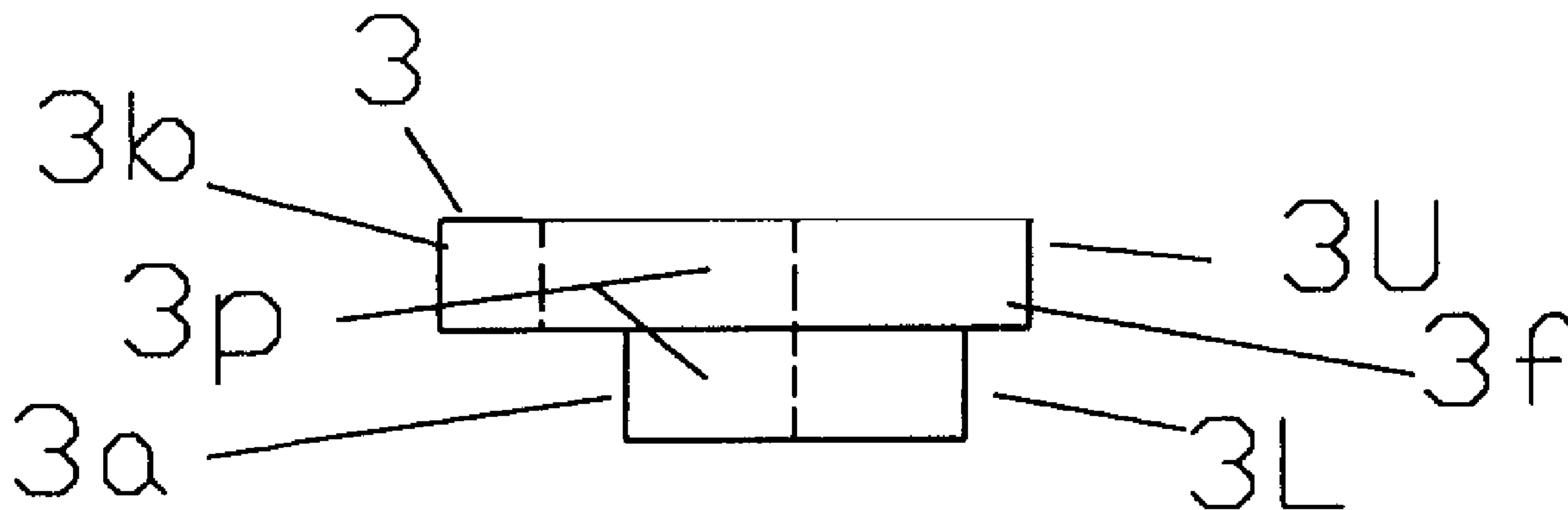

(22) Date de dépôt/Filing Date: 1998/01/21
 (41) Mise à la disp. pub./Open to Public Insp.: 1998/07/22
 (45) Date de délivrance/Issue Date: 2006/08/01
 (30) Priorité/Priority: 1997/01/22 (GB9701233-0)

(51) Cl.Int./Int.Cl. *E01B 9/48* (2006.01),
B66C 7/08 (2006.01), *E01B 9/66* (2006.01)
 (72) Inventeur/Inventor:
MOLYNEUX, GODFREY MATTHEW OWEN, US
 (73) Propriétaire/Owner:
MOLYNEUX, GODFREY MATTHEW OWEN, US
 (74) Agent: RICHES, MCKENZIE & HERBERT LLP

(54) Titre : ANCRAGE AJUSTABLE POUR RAILS DE GRUE
 (54) Title: ADJUSTABLE ANCHORAGE FOR CRANE RAILS



(57) **Abrégé/Abstract:**

An adjustable rail anchorage device including a rail clip and a cam rotatable around a fixed mounting bolt for laterally moving the rail clip into anchoring position on the rail. The cam includes a passageway for the mounting bolt and a circular boss portion with an outer circular wall having a gap defined at projected wall positions where the projected perimeter of the wall approximately coincides with the projected perimeter of the passageway to transfer lateral loads from the rail to the mounting bolt. A welded platform base with a raised haunch for locating the mounting bolt can be used to transfer lateral loads from the rail to the raised haunch.

- 21 -

ADJUSTABLE ANCHORAGE FOR CRANE RAILS**ABSTRACT OF THE DISCLOSURE**

An adjustable rail anchorage device including a rail clip and a cam rotatable around a fixed mounting bolt for laterally moving the rail clip into
5 anchoring position on the rail. The cam includes a passageway for the mounting bolt and a circular boss portion with an outer circular wall having a gap defined at projected wall positions where the projected perimeter of the wall approximately coincides with the projected perimeter of the passageway to transfer lateral loads from the rail to the mounting bolt. A welded platform base with a raised haunch for
10 locating the mounting bolt can be used to transfer lateral loads from the rail to the raised haunch.

ADJUSTABLE ANCHORAGE FOR CRANE RAILS

This invention relates to rail anchorages or rail clips which are used with all rails and is particularly concerned with rail clips for use with rails used by cranes.

BACKGROUND OF THE INVENTION

Adjustable rail anchorages are subject to very large lateral loads applied to the rails, particularly in crane rails by cranes as they travel along the rails, being cranes used for material handling in industrial facilities. Such cranes travel along rails which are supported generally on steel structures, the rails being maintained in the required position by rail anchorages that have to ensure that the rails remain located when very substantial lateral loads are generated, for example, when the crane is in motion. It is therefore important that the rails properly guide the cranes by being correctly aligned. Poorly aligned rails result in crane wheel wear and wear to the sides of the rail head and cause the crane to skew and bind against the rail. As a consequence even larger lateral forces can be generated on to the rail as the crane skews and binds. By providing an anchorage that is laterally adjustable the lateral alignment of the rail can be more easily established and maintained. However, when the rail anchorages offer adjustability other problems can occur. They can slip due to contamination by oil and grease which can drip from the crane axle and bearings as the crane travels along the rail. The oil and grease can lubricate the sliding surfaces of the adjustable anchorage. Also, adjustable rail anchorages are generally installed by a threaded bolt or threaded stud which requires careful attention that adequate torque is applied to the bolt or nut in order to prevent slipping of the anchorage.

Cam devices have been used in rail anchorage devices as a means of adjustment. Attempts have been made to prevent untoward cam rotation by use of

- 2 -

incremental locking positions, which have the result that only incremental adjustments are possible. The bolt or other fastening device provided has been placed centrally within a hole in the cam. In the prior art the application of the lateral load from the rail to the clip does not increase the frictional resistance of the cam against rotation within the rail clip.

In existing adjustable rail clips that are adjusted with a cam, the cam is a relatively bulky element. Consequently, the secondary element into which the cam is installed is also relatively large. This secondary element usually contacts the rail and is called a clip body. By reducing the size of these elements, but maintaining the strength, the rail clip can be installed in situations previously impossible to install an adjustable rail clip, or the same sized rail clip can be installed but having more lateral adjustment.

Figures 1 & 2 represent a cam in the prior art. Figure 1 is a side view and figure 2 is a plan view. The upper and lower parts of the cam are 1U and 1L respectively. The lower part of the cam 1L is a circular boss. There is an opening 1p in the upper and lower parts of the cam which is continuous. If a bolt is assembled inside this opening in the cam, the bolt is totally enclosed, in the plane perpendicular to the length of the bolt, by the opening in both the lower and upper parts of the cam. The walls of the opening encompass the bolt including at positions 1a and 2a, which is the narrowest part of the circular boss 1a.

It is desired to provide a smaller, more efficient, adjustable rail clip in plan view or bird's eye view, yet still have the same strength to resist lateral forces applied by the rail to the rail clip.

SUMMARY OF THE INVENTION

In accordance with the principles of the present invention there is provided an adjustable rail anchorage device including, a support surface for supporting a rail, and a bolt, welded stud and/or other fixing element connected to the support surface. The bolt or welded stud is generally threaded and is combined with a washer and threaded nut. A rail clip body is provided with an opening to

- 3 -

receive a cam. A cam rests on a surface of the clip body in order to position the cam in the vertical plane relative to the clip body and having a part with circular outer sides which are designed to engage with the sides of an opening in the clip body. The cam rotates within the clip body in the horizontal plane.

5 The cam has a vertical opening which provides for the passage of a bolt, welded stud or other fixing element. The center of the opening in the cam is off set from the center of the circular outer sides. The opening in the cam does not always encompass the bolt, welded stud or other fixing element. There is a gap in the wall of the opening where the projected perimeter of the circular outer sides of
10 the cam which engage with an opening in the clip body, and the projected perimeter of the opening in the cam approximately coincide. This allows the plan area of the cam to be smaller and consequently the plan area of the clip body to be smaller than such prior art devices. In prior art devices there is no gap in the walls of the opening and the bolt shaft is always enclosed in the horizontal plane by the walls of
15 the opening. In contrast, in the invention the gap in the wall of opening of the cam allows the bolt, stud or other fixing element to be positioned very close to or against the sides of the opening in the clip body.

 In one embodiment of the invention, a threaded bolt is positioned through a hole in a support surface, a threaded stud is welded to the support surface
20 or other fixing element is installed on the support surface. A clip body is positioned over the bolt, welded stud or fixing element so that the bolt, welded stud or fixing element passes up through a hole in the clip body. The clip body rests on the support surface and against the rail. The cam is passed down over the bolt, stud or fixing element, with the bolt stud or fixing element passing through an opening in
25 the cam, and a circular part of the cam is assembled into the hole in the clip body. Because the center of the opening in the cam is eccentric to the center of the circular part of the cam which rotates inside the hole in the clip body, the position of the bolt, stud or fixing element relative to the center of the clip body hole is also eccentric. Consequently, by rotating the cam in the horizontal plane, the circular
30 part of the cam engages with the hole in the clip body and the clip body moves

- 4 -

laterally relative to the bolt, stud or fixing element, relative to the support surface and relative to the rail. A gap in the walls of the opening of the circular part of the cam allows the bolt, stud or fixing element to be positioned close to or against the sides of the hole in the clip body, so that the lateral load from the rail to the clip
5 body may be transferred to the bolt, stud or fixing element, from the cam, from the clip body and cam combined or directly from the clip body.

In prior art devices, discounting the effects of friction on the surfaces of the parts of the complete assembled elements, the lateral load from the rail is always transferred by the cam to the bolt, stud or fixing element. When a nut and
10 washer are assembled onto the bolt and the nut tightened against the washer, this squeezes the washer onto the cam, and the cam onto the clip body, and the clip body onto the support surface. Consequently, the cam is prevented from rotating within the clip body and the position of the clip body relative to the support surface, relative to the bolt, stud or fixing element and relative to the rail is fixed. There is a
15 similar rail clip assembly on the other side of the rail, so that when the cams of each are rotated the lateral position of the rail can be adjusted and maintained in position.

Another embodiment of the invention reduces the bending moment of the lateral load being transferred to the bolt, stud or fixing element. This is achieved by lowering the contact point of the cam on the bolt, stud or fixing
20 element and where applicable lowering the contact point of the clip body on the bolt, stud or fixing element.

In another embodiment of the invention there is a base welded to the support surface and a bolt installed in the base. The base has a pocket into which the bolt head is installed and has a raised haunch area into which the shaft of a bolt
25 is installed and which captures the front of the bolt, that is the part of the bolt closest to the rail. A clip body with a hole to accept a cam, and then a cam are lowered over the bolt and the raised haunch. The cam has an opening to accept the bolt and the raised launch. The cam has a lower part which is a circular boss where the center of the opening is eccentric to the center of the boss and with a gap in the
30 walls of the opening where the projected perimeter of the circular boss and the

- 5 -

projected perimeter of the opening in the lower part of the cam approximately coincide.

The surfaces of the opening in the cam and/or the hole in the clip body are designed to bear against the front area of the raised haunch of the base, that is the outer surface of the raised haunch closest to the rail. By rotating the cam, the clip body will move laterally relative to the bolt and the base. Consequently, the clip body can be positioned laterally against the rail and the lateral position of the rail can be adjusted. When a nut and washer are assembled onto the bolt and the nut tightened against the washer, this squeezes the washer onto the cam, and the cam onto the clip body, and the clip body onto the base. Consequently, the cam is prevented from rotating within the hole in the clip body and the position of the clip body, relative to the base and relative to the rail, is fixed.

In one particular embodiment of the invention, prior to tightening the nut, the cam can be rotated within the clip body so that the majority of lateral load from the rail can be transferred by bearing, directly from the clip body to the front of the raised haunch of the base. Alternatively, the cam can be rotated to a position so that the lateral load is transferred from the clip body through the cam and then to the front of the raised haunch of the welded base. Alternatively, the cam can be rotated where both the cam and the clip body share in transferring the lateral load to the front of the raised haunch of the base. The proportion of the lateral load transferred through the cam or through the clip body depends upon the rotated position of the cam.

BRIEF DESCRIPTION OF THE DRAWINGS

The features of this invention which are believed to be novel are set forth with particularity in the appended claims. The invention may be best understood by reference to the following description taken in conjunction with the accompanying drawings, in which:

Figure 1 is a side view of a prior art cam element used in an adjustable anchorage for crane rails;

- 6 -

Figure 2 is a plan view of the prior art cam element of Figure 1;

Figure 3 is a side view of a cam element used in an adjustable anchorage for crane rails in accordance with the present invention;

Figure 4 is a plan view of the cam element of Figure 3;

5 Figure 5 is an end elevational view of a clip body used with the cam element of Figure 3;

Figure 6 is a side elevational view of the clip body of Figure 5;

Figure 7 is a plan view of the clip body of Figure 5;

10 Figure 7/1 is a plan view of the clip body of Figure 5 with added cross hatching to indicate a potential front bearing area;

Figure 8 is a side view of an assembled adjustable rail anchorage device according to the invention;

Figure 9 is a plan view of the rail anchorage device of Figure 8;

15 Figure 9/1 is a plan view of the rail anchorage device of Figure 8 with the nut and washer removed for convenience of illustration;

Figure 8/1 is a side elevational view of an adjustable rail anchorage device in accordance with another embodiment of the invention;

Figure 10 is a side view of an alternative cam embodiment of the present invention;

20 Figure 11 is a plan view of the cam element of Figure 10;

Figure 12 is an end elevational view of a clip body to be used with the cam element embodiment of Figure 10 in an adjustable rail anchorage device according to the invention;

Figure 13 is a side view of the clip body of Figure 12;

25 Figure 14 is a plan view of the clip body of Figure 12;

Figure 15 is a side view of an assembled adjustable rail anchorage device using the cam of Figure 10 and a clip body of Figure 12;

Figure 16 is a plan view of the assembled rail anchorage device of Figure 15;

- 7 -

Figure 15/1 is a side view of an assembled adjustable rail anchorage device in accordance with an alternative embodiment of the invention;

Figures A, B, B/1, B/2 and C are plan views of an adjustable rail anchorage device according to the invention in different rotated positions of the cam and with the washer and nut omitted for convenience of illustration;

Figure A/1 is a side view of the adjustable rail anchorage device of Figure A with the washer and nut included;

Figure 17 is a plan view illustrating a welded platform base used in an alternative adjustable rail anchorage device;

Figure 18 is an end view of the welded platform base of Figure 17;

Figure 19 is a side view of the welded platform base of Figure 17;

Figure 20 is a plan view of a cam element to be used with the welded platform base of Figure 17;

Figure 21 is a side view of the cam element of Figure 20;

Figure 22 is a side view of a washer;

Figure 23 is a side view of a threaded nut;

Figure 24 is a side view of a threaded bolt;

Figure 25 is a plan view of a clip body to be used with the welded platform base of Figure 17, cam element of Figure 20, and the washer, threaded nut and bolt of Figures 22-24;

Figure 26 is a side view of the clip body of Figure 25;

Figure 27 is an end view of the clip body of Figure 25;

Figure 28 is a plan view of the welded platform base of Figure 17 welded to a support surface;

Figure 29 is a side view of the welded platform base of Figure 28;

Figure 30 is a side view of the welded platform base of Figure 28;

Figure 31 is a side view of the welded platform base of Figure 28 similar to Figure 30 with the cam of Figure 20 assembled in position;

Figure 32 is a plan view of the assembly of Figure 30;

- 8 -

Figure 33 is a plan view of Figure 31 with internal structural lines removed for convenience of illustration;

Figure 34 is a side view of the assembly of Figure 31; and

Figure 35 is a plan view of the assembly of Figure 34.

5

DETAILED DESCRIPTION

Figure 3 is a side view of the cam element of the invention. Figure 4 is a plan view of the cam element 3 of the invention. 3U is the upper part of the cam and 3L is the circular boss at the lower part of the cam. 3f is a flange of the upper part of the cam. There is an opening 3p in the upper and lower parts of the cam. The opening 3P is continuous through the cam. The center of the opening 3P in the lower part of the cam is eccentric to the center of the circular boss 3L. The walls of the opening 3P are open at position 3a and 4a. This is where the projected perimeter of the circular boss 3L and the projected perimeter of the opening in the lower part of the cam approximately coincide. This is in the area where the sides of the circular boss 3L become the narrowest. 3b is the narrowest part of the upper part of the cam 3U in relation to the opening 3p and the outside perimeter of the upper part of the cam.

Figure 5 is an end view of the clip body 6, where 5a is a circular hole which receives a cam. Figure 6 is a side view of the clip body where 5a is a circular hole to receive a cam, 6a is the front area of the hole in the clip body and 6b is the part of the clip that overhangs the rail flange. Figure 7 is a plan view of the clip body, where 5a is a hole in the clip body, 7c is the front surface of the front area 6a of the hole and 6b is the part of the clip body that overhangs the rail flange. The front area of the hole in the clip body is the surface that is contacted by the circular boss of the cam or the bolt, stud or fixing element, where these parts of the invention are forced against the front surfaces of the hole in the clip body when lateral load is applied from the rail to the rail clip. Depending upon the fit of the circular boss of the cam with the circular hole in the clip body, this front surface 7c of the front area 6a may be almost the front half of the hole in the clip body. That is the half of the perimeter of the hole in the clip body

- 9 -

that is closest to the rail. This is shown in figure 7/1 where the potential front bearing area 7/1c is marked with hatching.

Figure 8 shows the invention assembled with the boss 3L of the cam installed in the hole 5a in clip body 6. The flanges 3f of the cam 3 rest on the clip body 6. The clip body is installed against the flange of a rail 8r. The clip body 6 and rail flange 8r rest on a support surface 8s. A threaded bolt 8c passes through a hole in the support surface 8s and through the hole 5a in the clip body 6 and the opening 3p in cam 3. The bolt could also be a threaded stud which is welded to the support surface 8s. In the figure the cam 3 has been rotated so that the opening 3p or gap in the boss 3L faces, that is opens, towards the rail 8r, which allows the front part 8a of the bolt shaft to resist lateral forces from the rail by bearing against the front area of the hole in the clip body at 6a, i.e., at front bearing area 7c. The invention is designed in this particular embodiment so when the cam is rotated in this position large lateral forces are not significantly transferred to the weak area 3b of the cam 3.

In this embodiment of the invention there is either incidental contact or no contact between the front 8a of the bolt shaft and the cam flange at 3b. When the cam is in this position the circular boss of the cam acts as a guidance means for the bolt, stud or fixing element to guide it to this position. When the bolt, stud or fixing element is in this position, since the lateral load is transferred directly from the clip body to the bolt, stud or fixing element, the boss part of the cam may not bear against the front of the hole in the clip body since it is not involved with the transfer of lateral forces from the rail, except for part of the lateral load that is transferred to the cam by surface friction after a nut has been assembled on the invention and tightened on the bolt or welded stud, as described later in this description.

Figure 9 is a plan view of Figure 8 where 6 is the clip body, 3 is the cam, 8d is the washer, 8b is the nut, 8c is the bolt or stud and 8r is the rail. Figure 9/1, is a plan view, where the nut and washer have been removed for clarity, and showing no contact of the boss 3L of the cam with the front area 9a of the hole

- 10 -

in the clip body. Lateral forces are transferred from the clip body 6 directly to the bolt or welded stud 8c.

In another embodiment of the invention where lateral forces are small the lateral load can be transferred to the cam at 3b and there may be equal
5 contact of the bolt/stud/fixed element with the cam and clip body or contact only with the cam. This can be seen in Figure 8/1 where the front of the bolt shaft 8a does not quite touch the front area 6a of the hole in the clip body 6 because contact is made with the flanged area of the cam at 3b. With reference to figure 8/1, under these circumstances where load is transferred via the cam at 3b the boss of the cam
10 will engage with the surfaces of the front of the hole in the clip body and receive lateral load from the clip body. Contact may ultimately be made by the front of the bolt shaft 8a with the front area of the hole in the clip body at 6a, if lateral loads from the rail are large enough to cause the bolt 8c to locally deform the flange of the cam at 3b. In both Figures 8 and 8/1 before the washer 8d and nut 8b are
15 assembled on the bolt and the nut tightened, the cam 3 can be rotated in clip body 6, so as to adjust the lateral position of the clip body 6 relative to the bolt or stud 8c, relative to the support surface 8s and relative to the rail 8r, so the lateral position of the rail 8r can be adjusted. Once the nut 8b is tightened on the bolt 8c this compresses the washer 8d against the cam 3, which is compressed against the clip
20 body 6, which is compressed against the support surface 8s, so the cam will not rotate, even when large lateral loads are applied to the rail clip.

Figures 10 through 16 show an amendment to the invention where the lateral load from the rail is transferred lower on the bolt, welded stud or fixing element. Figure 10 is a side view of the cam 10 and Figure 11 is a plan view, where
25 10U is the upper part of the cam, 10L is a circular boss at the lower part of the cam and 10p is a continuous opening in the cam. 10b is the narrowest part of the upper part of the cam 10U in relation to the opening 10p and the outside perimeter of the upper part of the cam. There is a gap in the walls of the opening 10p in the circular boss or lower part of the cam 10L at positions 10a and 11a where the projected
30 perimeter of the circular boss and the projected perimeter of the opening in the

- 11 -

lower part of the cam approximately coincide. The inner walls 10w of the opening 10p in the cam slope inwards towards the lowest part of the cam, so that the radius of the opening is smaller lower down the opening. Similarly the outer walls 10x of the lower part of the cam 10L also slope towards the center so that the small radius is lower down on the cam. Figure 12 is an end view of the clip body. Figure 13 is a side view of the clip body 14, where 13a is the front part of the hole at its smallest radius lower down in the clip body, closer to the support surface. 13b is the part of the clip body that overhangs the rail flange. Figure 14 is a plan view of the clip body where 14a is the hole in the clip body which receives the cam, 13b is the part of the clip body that overhangs the rail and 14c is the front area of the hole which transfers lateral load to the bolt or stud, or to the boss of the cam. Figure 15 shows the invention assembled with the clip body 14 resting on the support surface 8s.

The clip body is positioned against the rail flange 8r. The circular boss 10L of the cam 10 is positioned inside the hole in clip body 14. Threaded bolt 15c is positioned through a hole in the support surface 8s, or threaded welded stud 15c is welded to the support surface 8s and passes up through the hole in the clip body 14 and through the opening in cam 10. A washer 15d is placed over the bolt or stud with a threaded nut 15b tightened down so that it compresses against the washer.

In Figure 15 the contact of the front of the bolt or stud 15a is lower in the clip body hole at 13a. The amendment to the design provides a lower contact point of the clip body and/or cam on the front of the bolt shaft 15a. This reduces the bending moment applied to the bolt by the lateral load from the rail. Figure 16 is a plan view of Figure 15 where 16a is the rail, 14 is the clip body, 10 is the cam, 15d is the washer, 15b is the nut and 15c is the bolt or welded stud.

Figure 15/1 is an additional amendment where at the point of contact with the stud or bolt 15/1c, the front of the hole in the clip body and/or the cam can correspond to the bolt surface to which it is transferring load by an increase in the contact or bearing area. This is seen at positions 15/1a and 15/1b where contact areas have been increased by a radius and can also be increased by flattening out

- 12 -

mating areas where lateral load is transferred. This is particularly important where larger lateral loads are involved in order to reduce bearing stresses in the contacting surfaces.

Figures A, B, B/1, B/2 and C are plan views of the invention showing different rotated positions of the cam 3 in the hole in clip body 6. Each figure includes a plan view of the bolt or stud shaft 8c installed with the invention. The washer and nut have been omitted for clarity. Various contact positions of the front 8a of the bolt shaft 8c with the cam 3 and the clip body 6 are illustrated in these three figures when substantial lateral forces are applied from the rail 8r to the clip body. In Figure A the cam 3 is rotated so that the contact with the front 8a of the bolt shaft 8c occurs only on the inner walls of the opening in cam 3. Lateral forces from the rail 8r are consequently transferred to the clip body 6 and then to the cam 3 at area 7c of the front of the hole in the clip body, before they are transferred to the bolt shaft.

Figure A/1 is a side view of Figure A, but the washer 8d and nut 8b are included. The flange 3f of the cam rests on the clip body. The front 8a of the bolt or stud is bearing against the sides of the opening in the cam 3. The boss 3L of the cam 3 is bearing against the front area 7c of the hole 5a in the clip body 6. The clip body 6 is positioned against the rail 8r.

In Figure B the front 8a of the bolt shaft bears against the front area 7c of the hole 5a in the clip body 6. In Figure C the cam 3 is rotated to the intermediate position where the bolt shaft 8c bears against both the inner sides of the cam opening and the sides of the hole in the clip body. The proportion of the bearing of the bolt or stud on the cam and the bolt on the front area 7c of the hole 5a in the clip body, to transfer the lateral load from the rail, varies depending upon the rotated position of the cam.

In Figures A, B, B/1, B/2 and C there is a slight tolerance gap shown between the outer sides of the circular boss or lower part of the cam and the sides of the hole in the clip body. This gap allows the circular boss 3L of the cam to be installed in the hole 3p in the clip body 6. There is also a tolerance gap between the

- 13 -

bolt shaft 8c and the opening 3p in the cam 3 which allows assembly of the bolt within the opening of the cam. After the nut 8b has been tightened on the bolt or stud, with the clip assembly compressed onto the support surface, when large lateral forces are received from the rail by the clip body, which overcome any friction
5 between the clip body and the support surface, and the cam and the clip body, relative movement will occur between these elements until all these gaps are behind the bolt shaft and bearing occurs on the front of the bolt shaft with, no gaps between the front of the shaft 8a, any of the elements of the rail clip and the rail flange where it bears against the clip body. For example, in Figure A, the tolerance
10 gaps to the rear of the bolt or stud 8c are shown at position 8e. This is the condition shown in Figures A, B/2 and C.

With reference to Figure B/1, if load however is transferred directly from the clip body 6 to the bolt, stud or fixing element 8c, then there may be a space between the front surfaces of the hole in the clip body and outer surfaces of
15 the boss of the cam that engage with the hole in the clip body at area B/1a, even with the application of large lateral loads from the rail. This is because the cam is bypassed in transferring the lateral load from the rail to the bolt, stud or fixing element. However, there is no gap between the front of the bolt 8a, the clip body 6 and rail 8r. Figure B/2 shows an alternative to the invention where in the case of
20 smaller lateral loads, the lateral loads from the rail may be transferred from the clip body 6, to the areas of the cam boss 3L in contact with the front part of the hole in the clip body at area B/2a, then to the cam flange at position 4b and then to the front 8a of the bolt. In this example there is a gap between the front 8a of the bolt or stud and the front of the hole in the clip body at area 7c. Figure A/1 shows a
25 side view of this embodiment of the invention except a nut and washer have been added.

In another embodiment of the invention, instead of a bolt passing through a hole in the clip body, a raised haunch on a welded platform base, with a bolt assembled inside, passes through the hole in the clip body and the opening in
30 the cam. The raised haunch combined with the bolt replace the bolt/welded stud in

- 14 -

the previous embodiment of the invention. The illustrations regarding the positions of the cam relative to the clip body and the bolt or stud shown in Figures A, B, B/1, B/2 and C are relevant to this embodiment of the invention. Figure 17 is a plan view of a welded platform base 17, where 17a is a raised haunch on the base and 17b is a bolt passageway and 17c is a pocket to receive a bolt head. Figure 18 is an end view of the welded platform base, where 17a is the raised haunch on the base, 17b is the bolt passageway and 17c is the bolt head pocket. Figure 19 is a side view of the welded platform base, where 19a is the front area of the raised haunch 17a that receives the lateral load from the cam or the clip body, 17b is the bolt passageway and 17c is the pocket to receive a bolt head.

Figure 20 is a plan view of a cam 20 where 20a is the gap in the boss of the cam where the projected perimeter of the circular boss and the projected perimeter of the opening in the lower part of the cam approximately coincide. 20b is the narrowest part of the upper part of the cam in relation to the opening and the outside perimeter of the upper part of the cam. 20c is the opening in the cam. Figure 21 is a side view of the cam, where 21U is the upper flange part of the cam and 21L is the circular boss or lower part of the cam with a gap in the wall forming the boss 21L. 20a is the gap in the boss of the cam where the projected perimeter of the circular boss and the projected perimeter of the opening in the lower part of the cam approximately coincide. The wall 21a forming the boss 21L slopes inwardly away from the gap 20a as shown in Figures 20 and 21. 20b is the narrowest part of the upper part of the cam relative to the opening in the cam and the perimeter of the upper part of the cam. 21c is the surface of the inner wall of the opening in the cam that applies the load to the front 19a of the raised haunch 17. The center of the opening in the lower part of the cam is eccentric to the center of the circular boss.

Figure 22 is a side view of a washer 22. Figure 23 is a side view of a threaded nut 23. Figure 24 is a side view of a threaded bolt.

Figure 25 is a plan view of a clip body 25, where 25a is the front area of a hole in the clip body and 25b is the part of the clip body that overhangs a

- 15 -

5 rail flange. Figure 26 is a side view of the clip body 25, where 26a is the front area of the hole in the clip body which apples the load to the cam and/or to the raised haunch of the welded platform base. 26c is the leg of the clip body which receive the lateral load from the rail. Figure 27 is an end view of the clip body, where 26c are the legs of the clip body that receive the lateral load from the rail and 27b is the hole that receives the boss of the cam.

10 Figure 28 is a plan view of the welded platform base, where 28a is a weld that fixes the base to the support surface and 24 is a bolt installed inside the base. Figure 29 is a side view of the platform base, where the weld 28 fixes the base 17 to the support surface 8s. Bolt 24 is installed inside the base. The weld has been omitted from Figures 30 to 35 for clarity.

15 Figure 30 is a side view of the welded platform base 17, where the bolt 24 is installed in the base and the clip body 25 is installed over the bolt 24 and the raised haunch 17a of the base and the clip body also rests on the base 17. The legs 26c of the clip body 25 abut the rail 8r. The front area of the hole in the clip body 25 is installed against the front area 19a of the raised haunch 17. Figure 31 is a view identical to Figure 30 except the cam 21 has been installed over the bolt 24 and raised haunch 18a. The front area of the hole in the clip body at 26a bears against the front area of the raised haunch at 19a. The cam is rotated so that the gap in the boss of the cam faces forward and opens towards the rail 8r. This allows the front area of the hole in the clip body at 26a, to bear against the front area 19a of the haunch on the welded platform base. The area of the upper part of the cam, where the distance between the outer perimeter of the cam and the opening in the cam is at its narrowest 20b, is closest to the rail 8r, and there is a gap between the front 19a of the raised haunch and 20b of the upper part of the cam, to ensure that the lateral load from the rail is transferred by bearing from the front of the hole in the clip body at 26a to the front of the raised haunch on the base at 19a without passing through the cam 20b or any other parts of the cam, discounting friction between the various parts of the invention when fully assembled.

20

25

- 16 -

In this embodiment of the invention there may be incidental contact between the front 19a of the raised haunch and the cam flange at 20b. The cam can also be rotated to the intermediate position where both the cam and the clip position where the lateral load from the rail 8r is transferred from the clip body, to the boss of the cam and to the front of the raised haunch of the base via the inner surfaces of the opening in the cam. Because the base is welded to the support surface 8s, by rotating the cam, the clip body moves laterally relative to the welded base, the support surface and the rail. This allows the lateral position of the rail to be adjusted when complimented with another adjustable rail clip on the other, opposing side of the rail.

In another embodiment of the invention lateral loads may be equally transferred by the cam at 20b and by the front of the hole at 26a, to the front 19a of the raised haunch. In another embodiment of the invention where there are light lateral loads, lateral loads from the rail may be transferred from the clip body, to the areas of the boss of the cam in contact with the sides of the hole in the clip body in area 26a and to the cam at 20b and then to the front of the raised haunch of the base.

Figure 32 is a plan view of Figure 30, where bolt 24 is positioned inside base 17 and clip body 25 is assembled over the bolt 24 and raised haunch 17a. The clip body legs 26c are abutting rail 8r. 25b is the part of the clip body that overhangs the rail. Figure 33 is a plan view of Figure 31, with internal structural lines removed for clarity, where clip body 25 is installed on the base 17 and over bolt 24 and base haunch 17a, with cam 20 installed with the area of the cam 21b in the forward position. Rail 8r abuts the clip body under 25b, the part of the clip body that overhangs the rail. Figure 34 is a side view as Figure 31 except washer 22 and nut 23 are installed on the threaded bolt 24. When nut 23 is tightened it compresses washer 22 against the cam 20, which is compressed against the clip body 25, which is compressed against base 17. Base 17 is welded to support surface 8s. Once the nut 23 is tightened as above, the cam will not rotate within the clip body 25 and any lateral loads from the rail will be resisted without

- 17 -

any lateral movement of the clip body. Figure 35 is a plan view of Figure 34 where 17 is the base, 25 is the clip body, 20 is the cam, 22 is the washer, 23 is the nut, 24 is the bolt and 8r is the rail.

5 The foregoing detailed description has been given for clearness of understanding only, and no unnecessary limitations should be understood therefrom, as modifications will be obvious to those skilled in the art.

- 18 -

WHAT IS CLAIMED IS:

1. An adjustable rail anchorage device comprising a support surface for a rail, a mounting member maintained fixed in position with respect to said support surface, a rail clip coupled to the mounting member for anchoring the rail, and a cam engaging the rail clip and the mounting member so that rotation of the cam around the mounting member enables lateral movement of the rail clip and the cam can be maintained in position with threaded locking means engaging the mounting member, the improvement comprising:
- 5 said rail clip having an opening therethrough;
- 10 said cam having a flange portion, a lower circular boss portion engaged within said opening in said rail clip, and a passageway through said cam for passage of said mounting member, with the longitudinal axis through the center of the passageway offset from the longitudinal axis through the center of the lower circular boss portion, said cam upper flange portion mounted adjacent said rail clip;
- 15 said lower circular boss portion includes an outer circular wall including a gap in the wall defined at projected wall positions where the projected perimeter of the wall approximately coincides with the projected perimeter of the passageway so as to locate said mounting member immediately adjacent the opening in said rail clip;
- 20 said rotation of the cam around the mounting member enabling the lower circular boss portion engaged within the rail clip opening to move the rail clip laterally relative to the rail; and
- said gap in the outer circular wall enabling the mounting member to be moved adjacent the rail clip within said rail clip opening, so that the lateral load from the rail to the rail clip may be transferred to the mounting member from one of
- 25 (a) the cam, and (b) the rail clip and cam combined, and (c) directly from the rail clip.
2. An adjustable rail anchorage device according to claim 1, wherein said rail clip includes an overhang portion for engaging the rail.

- 19 -

3. An adjustable rail anchorage device according to claim 1, wherein said opening through said rail clip includes inner circular wall surfaces engaged at a surface area of engagement by one of the outer circular wall portion of said boss portion and said mounting member.

5 4. An adjustable rail anchorage device according to claim 3, wherein said surface area of engagement can be up to one-half of said inner circular wall surface of said rail clip opening.

5. An adjustable rail anchorage device according to claim 1, wherein said mounting member is secured to said support surface.

10 6. An adjustable rail anchorage device according to claim 1, wherein said outer circular wall including a gap of said lower circular boss portion slopes inwardly away from the cam flange portion.

7. An adjustable rail anchorage device according to claim 6, wherein the cam passageway has a reduced diameter from the cam flange portion towards
15 the lower circular boss portion to enable engagement of the mounting member in said rail clip opening to be at positions closer to said support surface.

8. An adjustable rail anchorage device according to claim 1,
including:

20 a platform base rigidly mounted to said support surface, said platform base including a raised haunch extending upwardly therefrom including a pocket for receiving and maintaining said mounting member fixed within said raised haunch with a portion of said mounting member extending from said raised haunch.

- 20 -

9. An adjustable rail anchorage device according to claim 8, wherein said rail clip and said cam are mounted on said mounting member and said raised haunch.

10. An adjustable rail anchorage device according to claim 9,
5 wherein the lateral load from the rail to the rail clip may be transferred to said raised haunch.

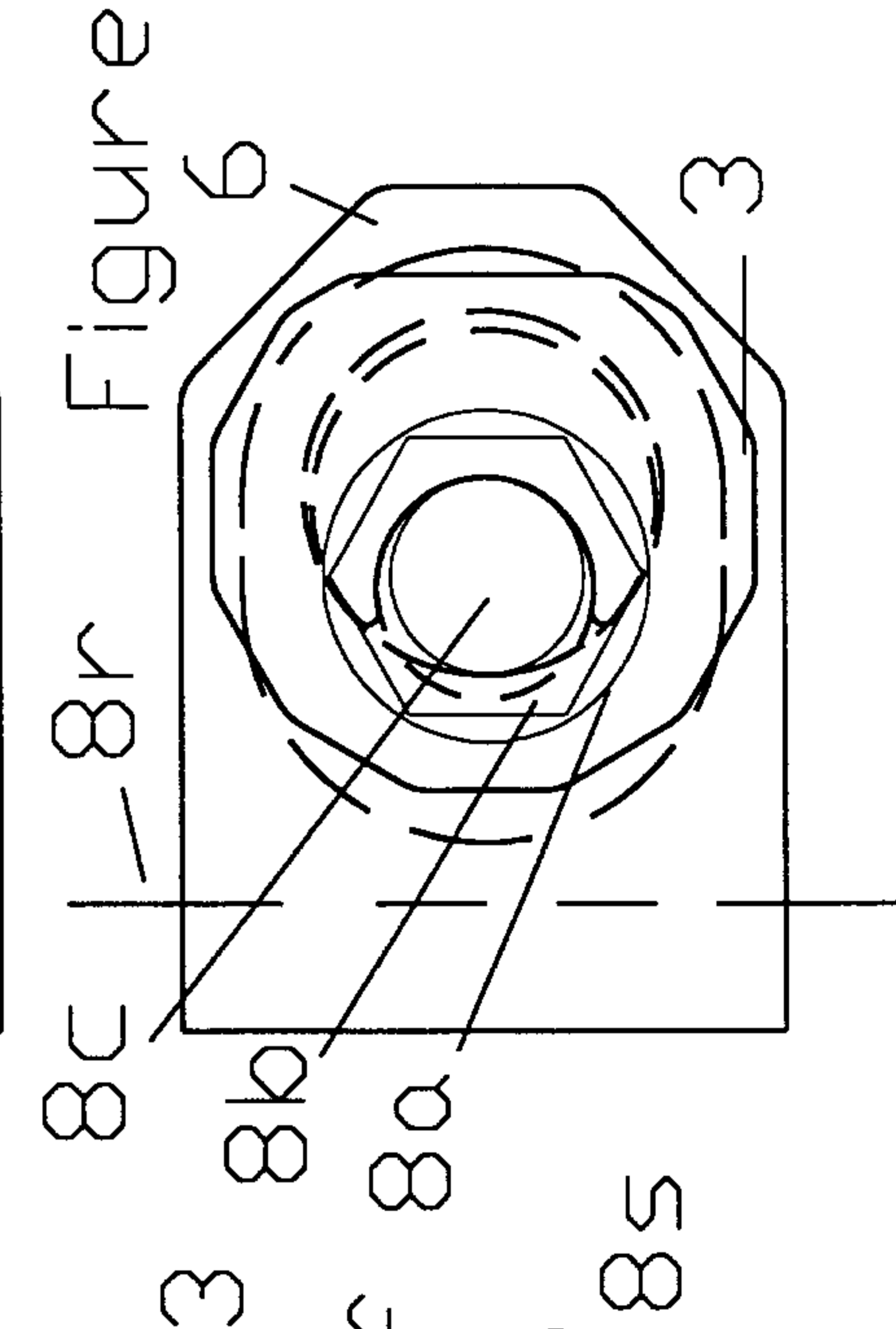
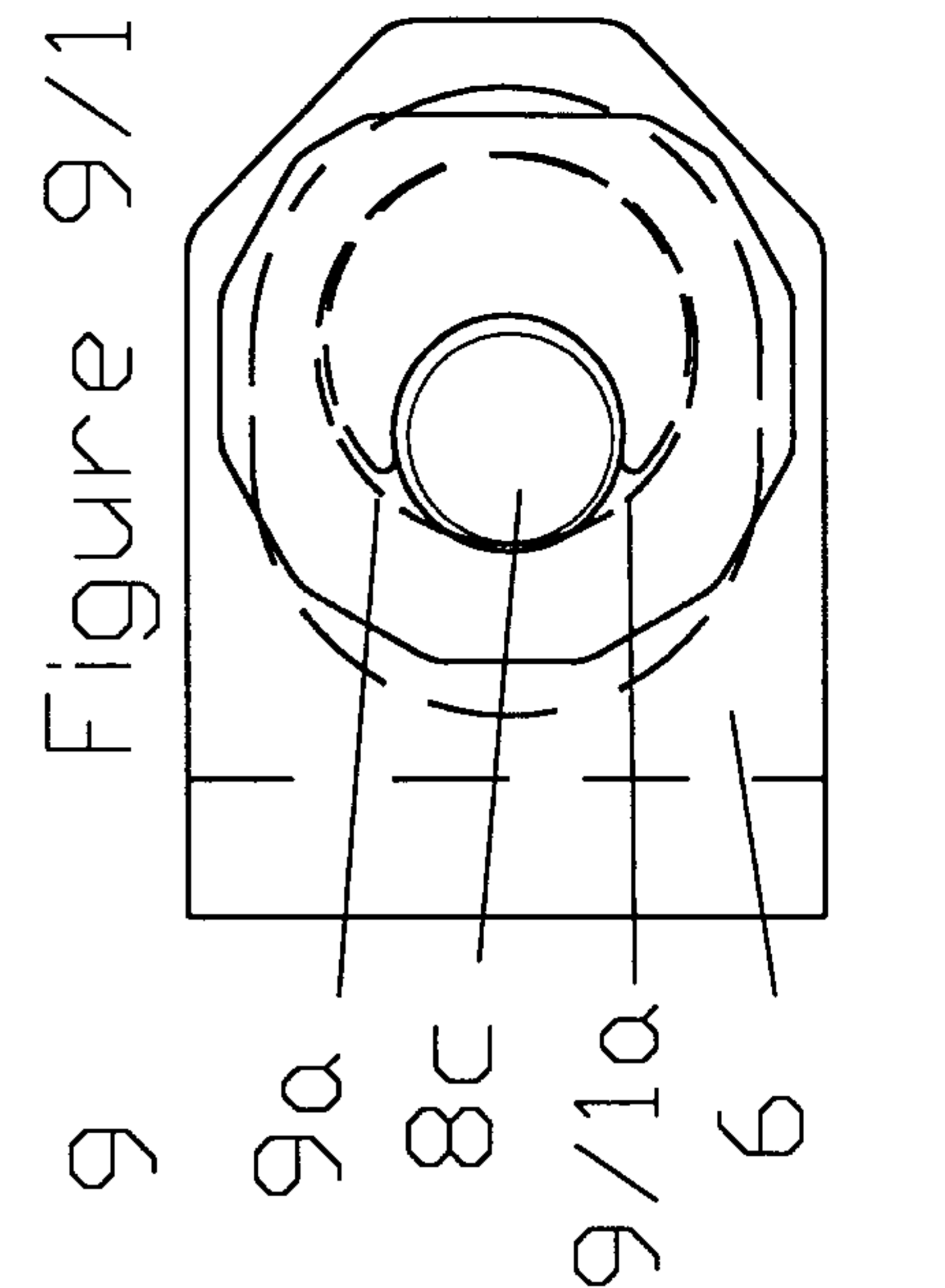
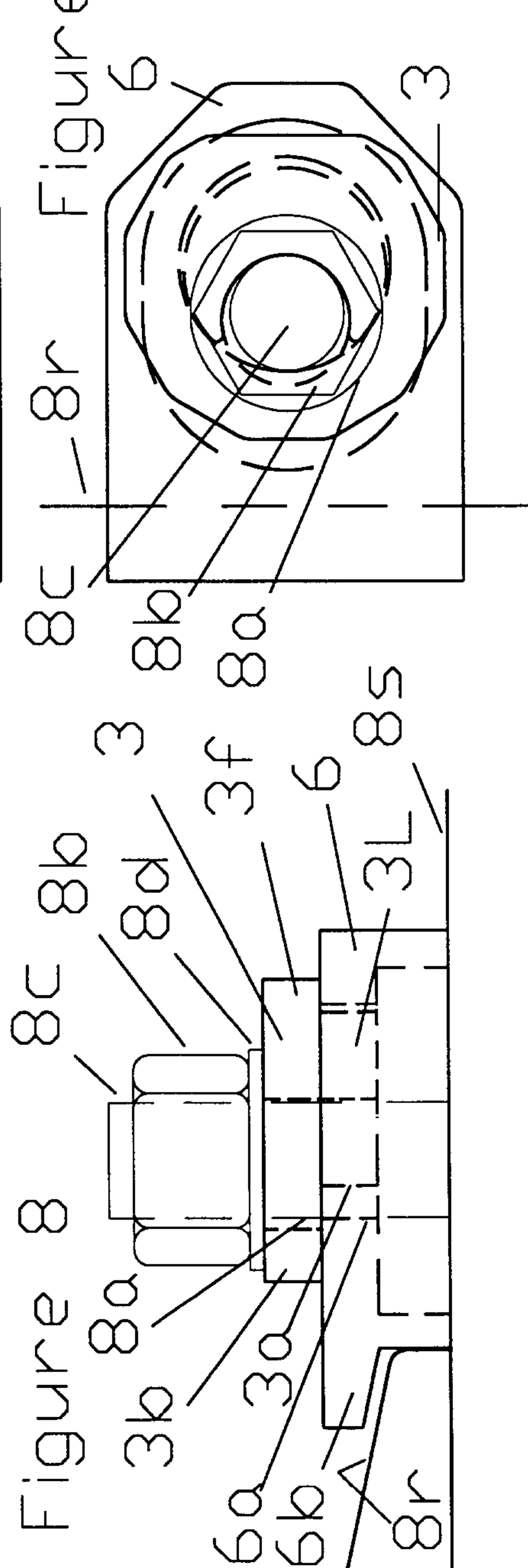
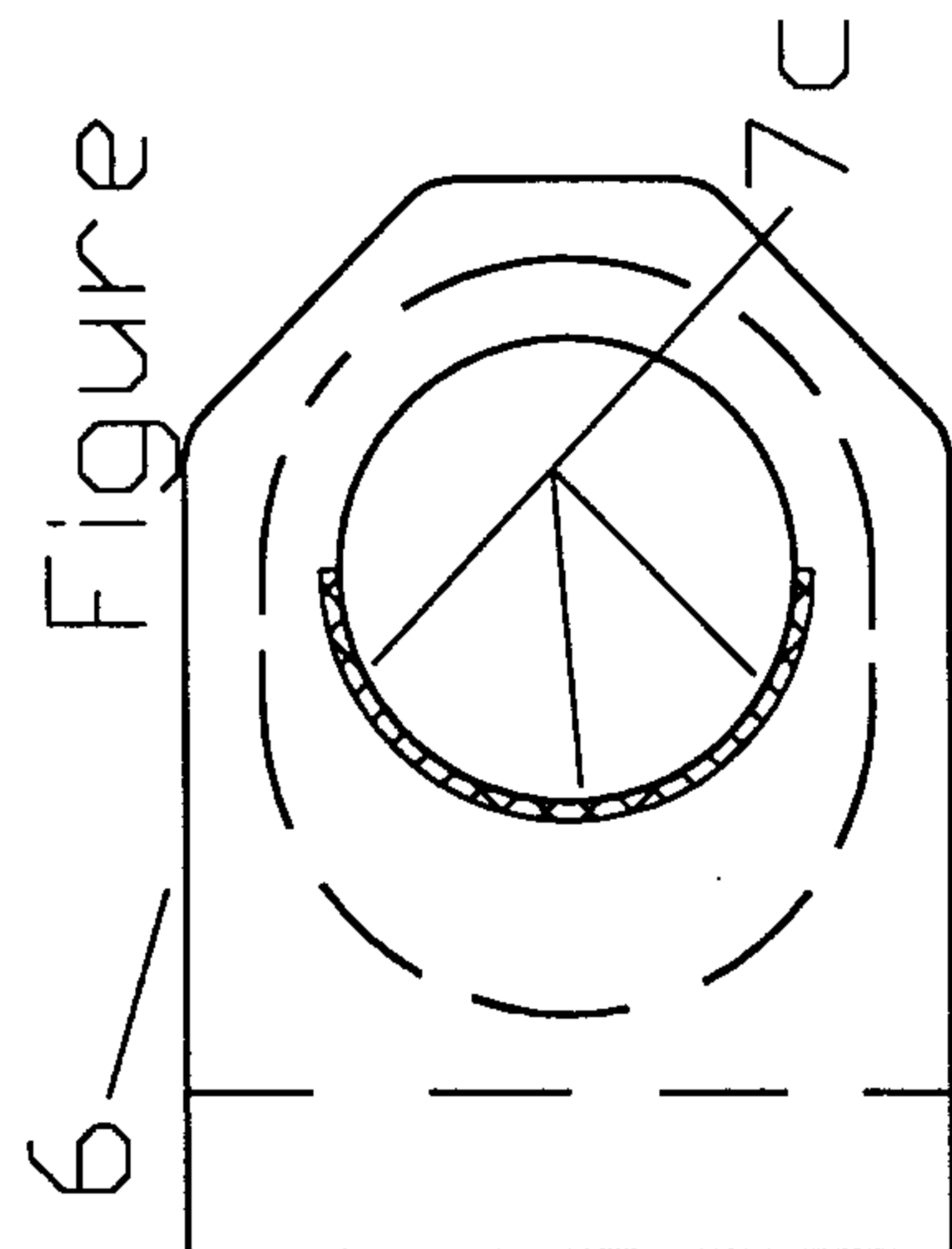
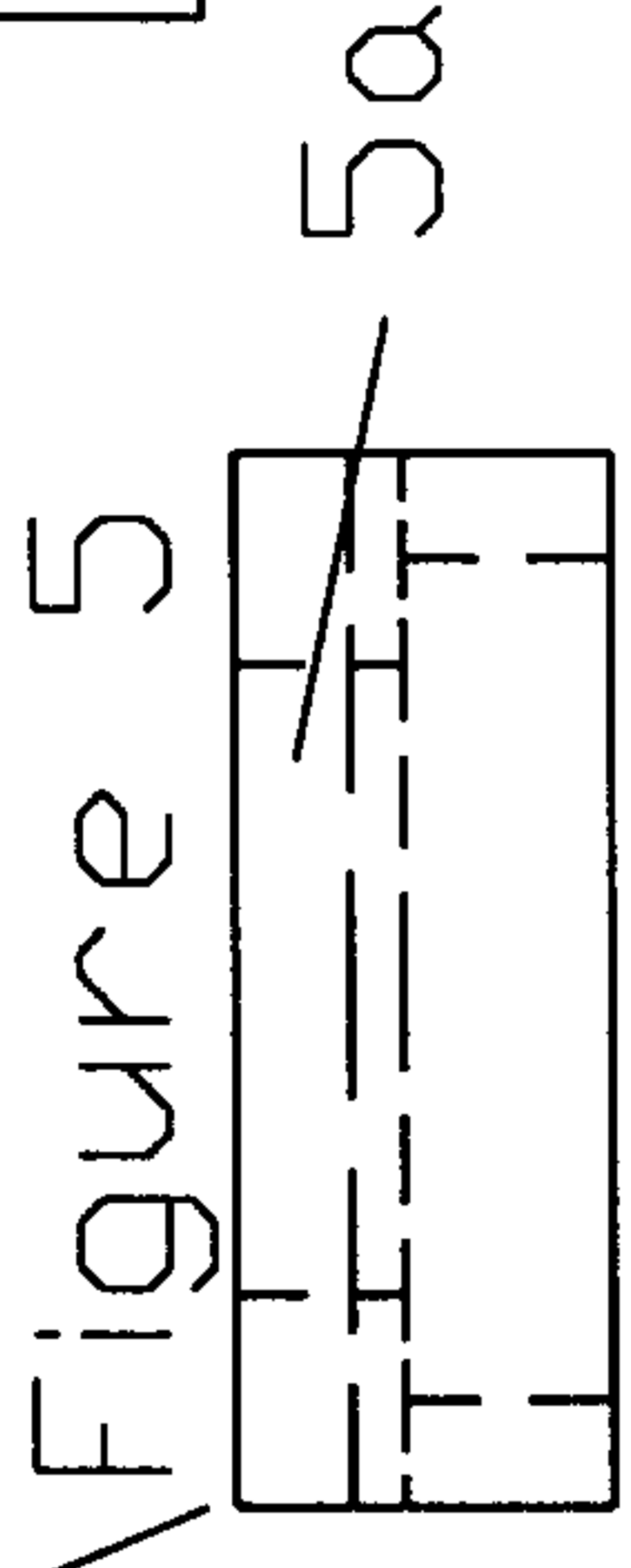
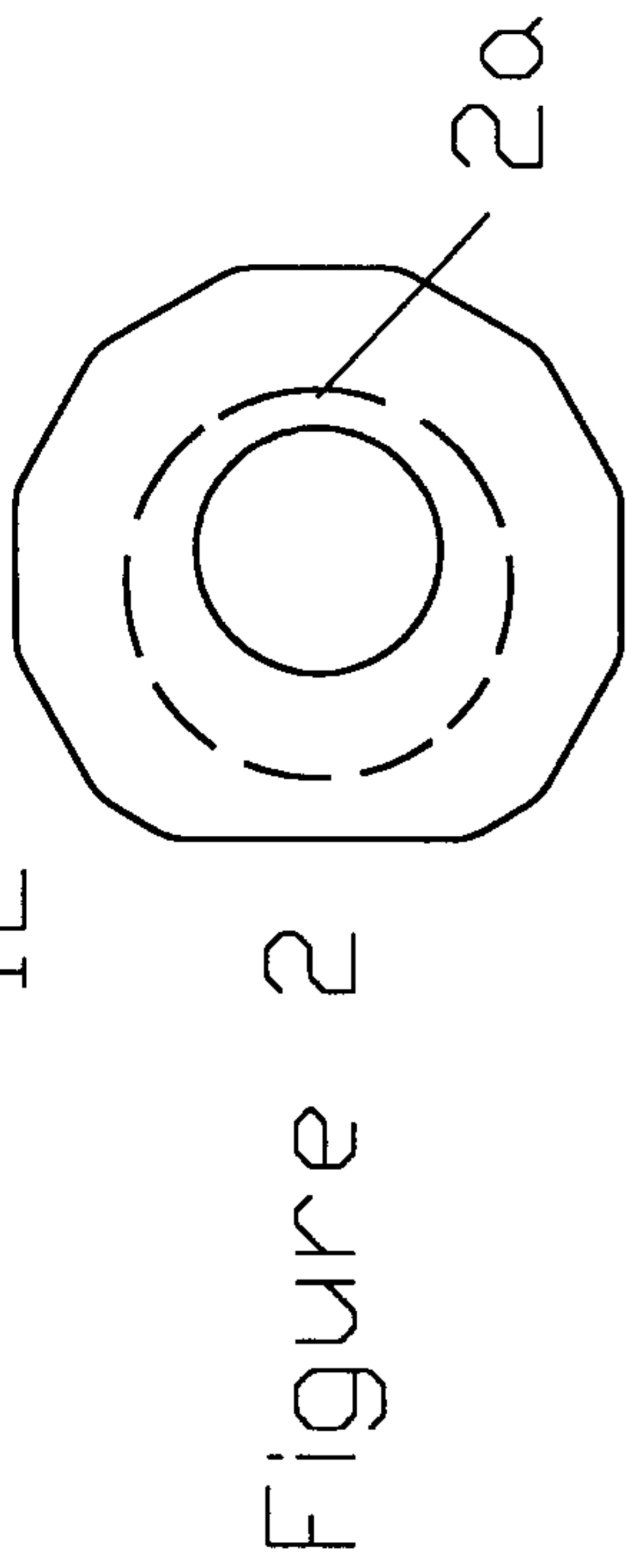
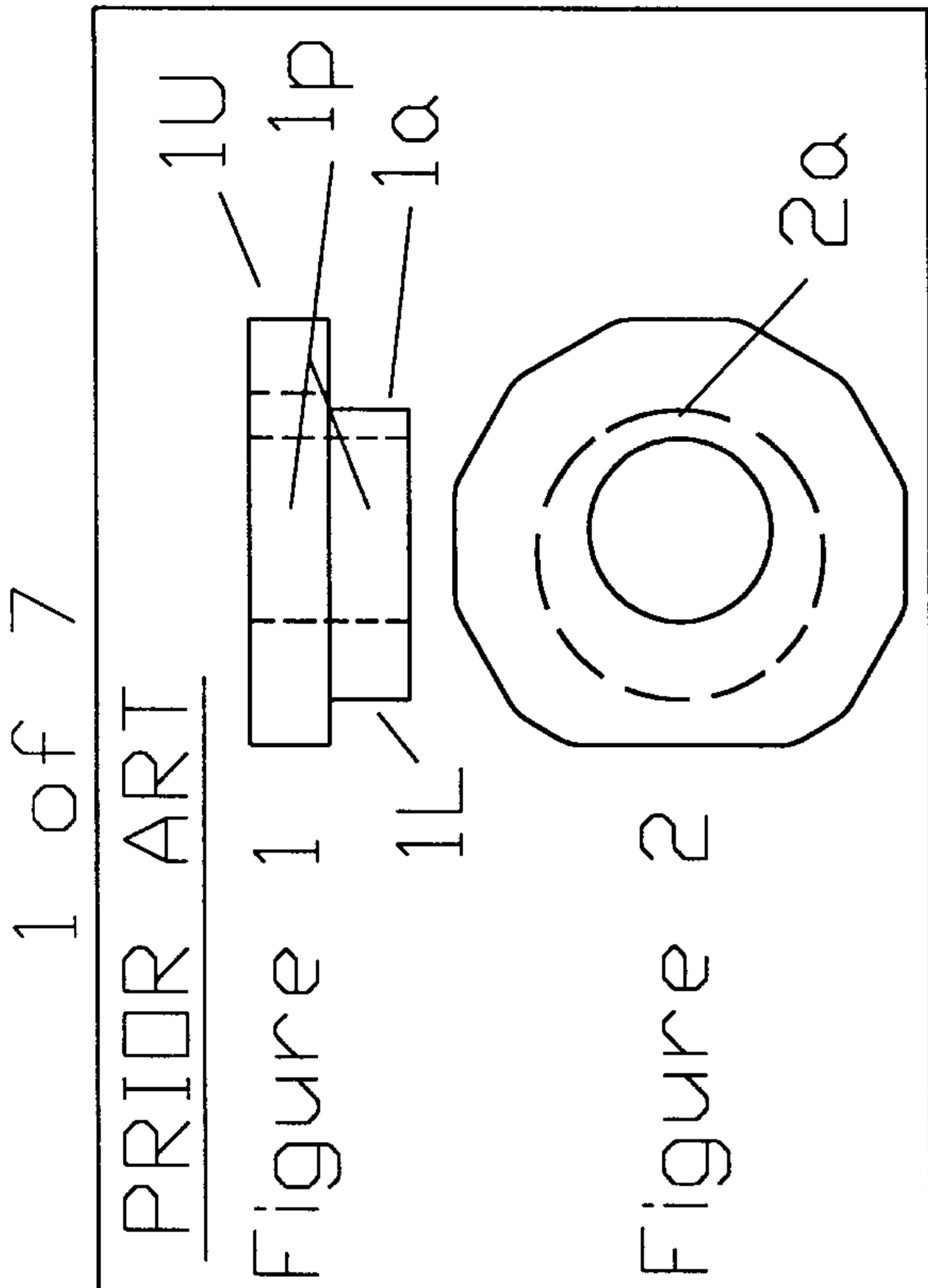
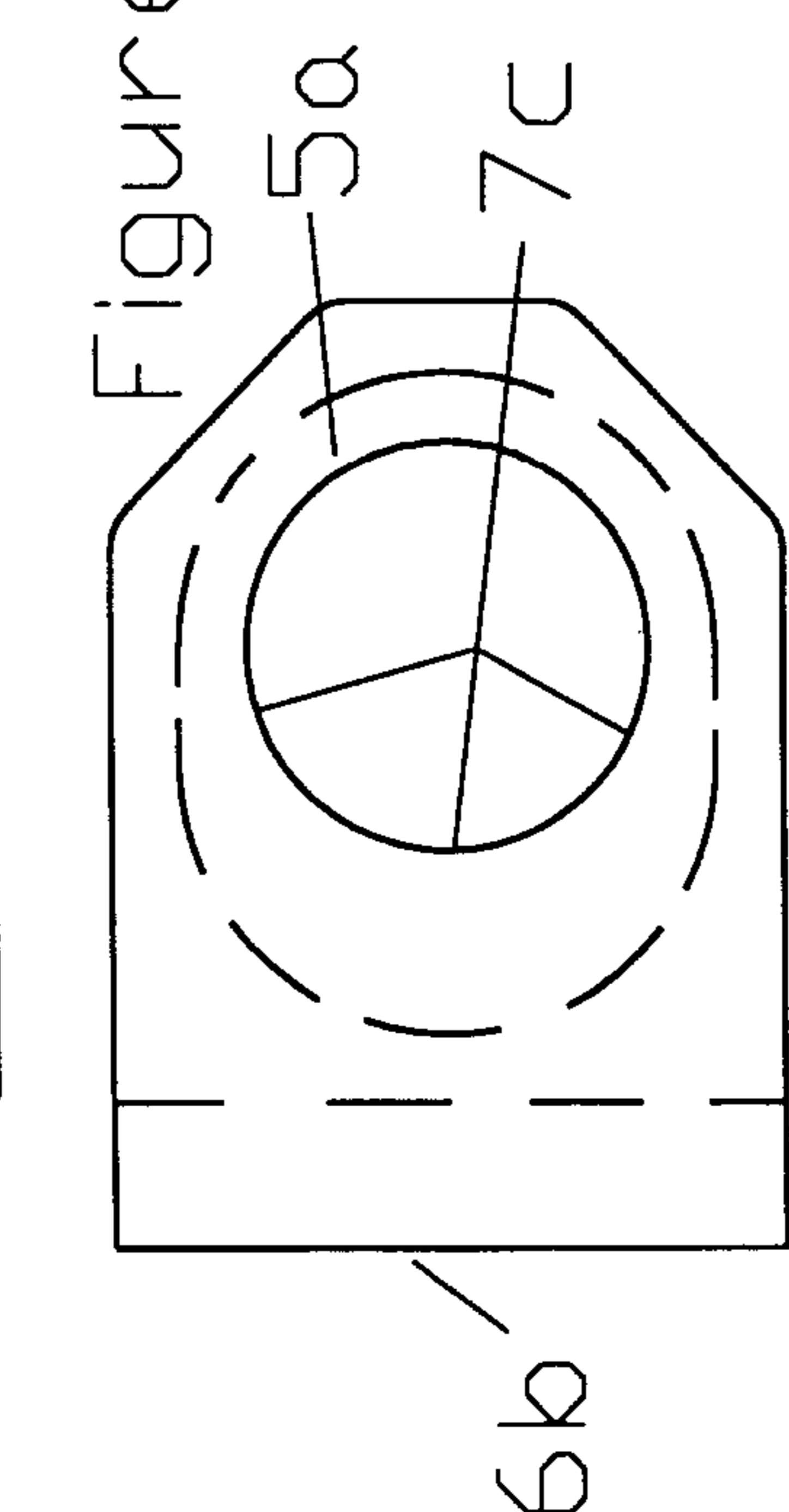
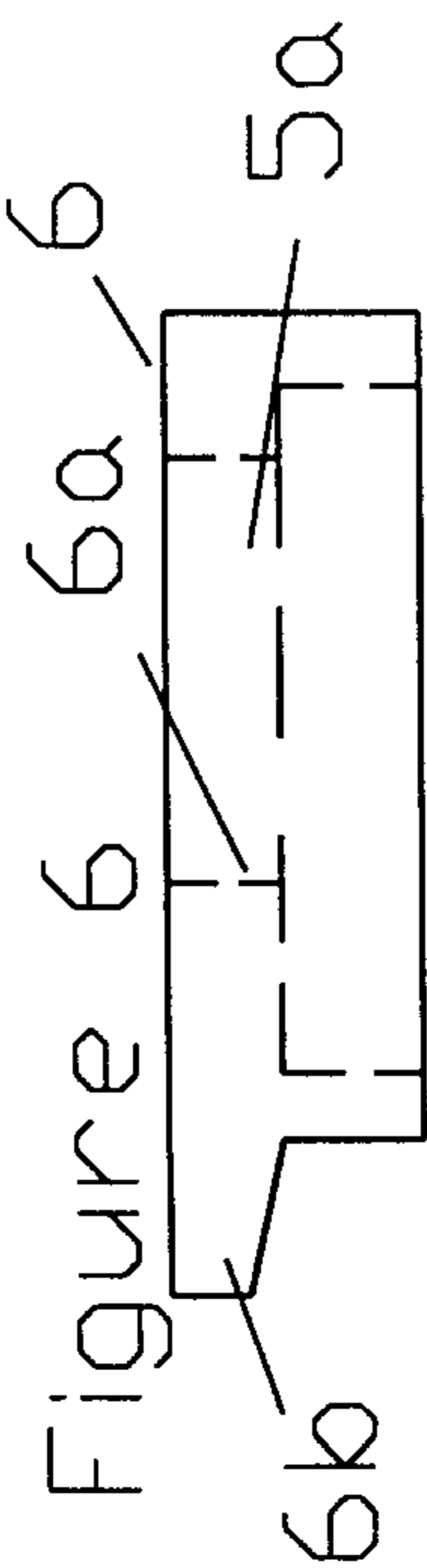
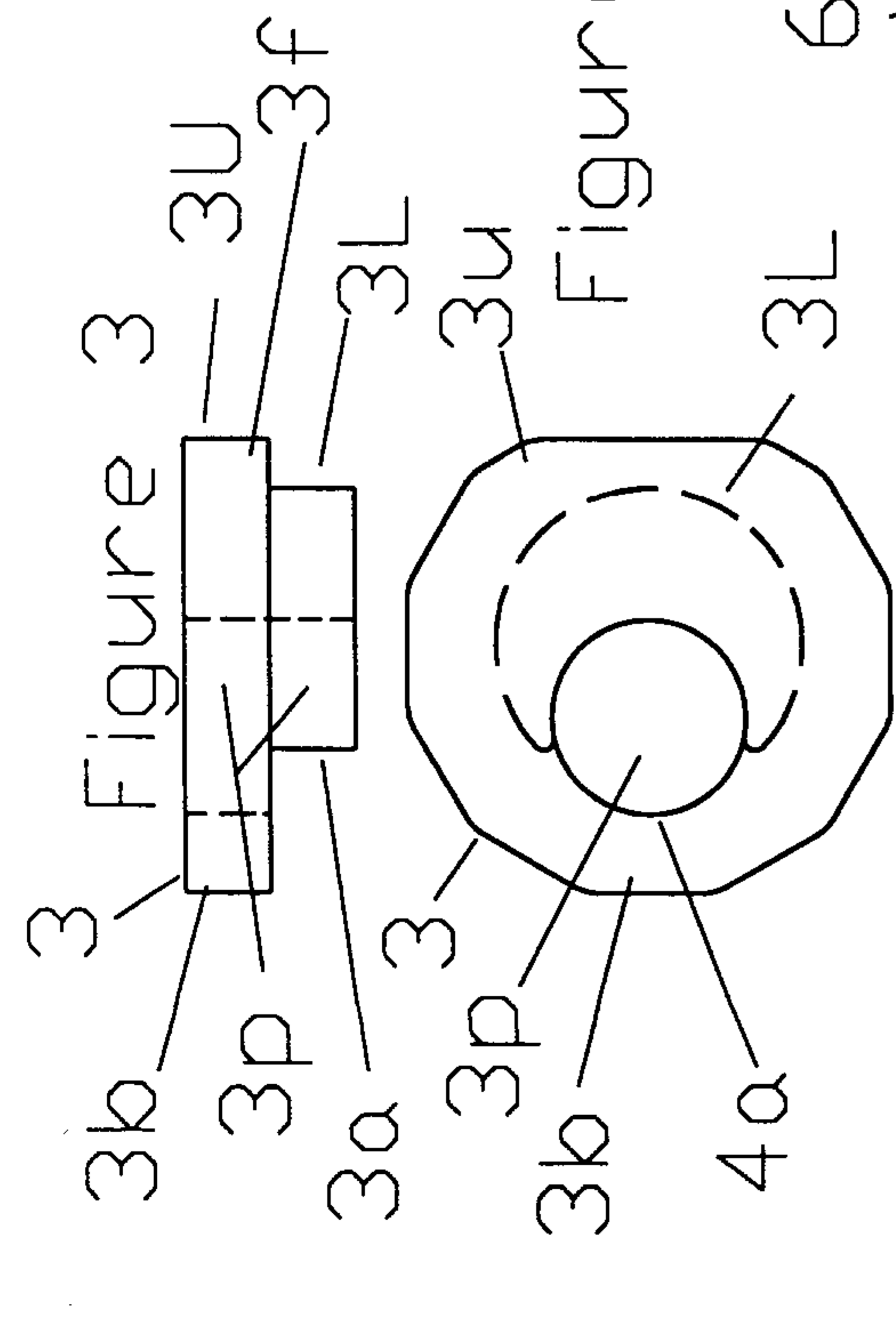

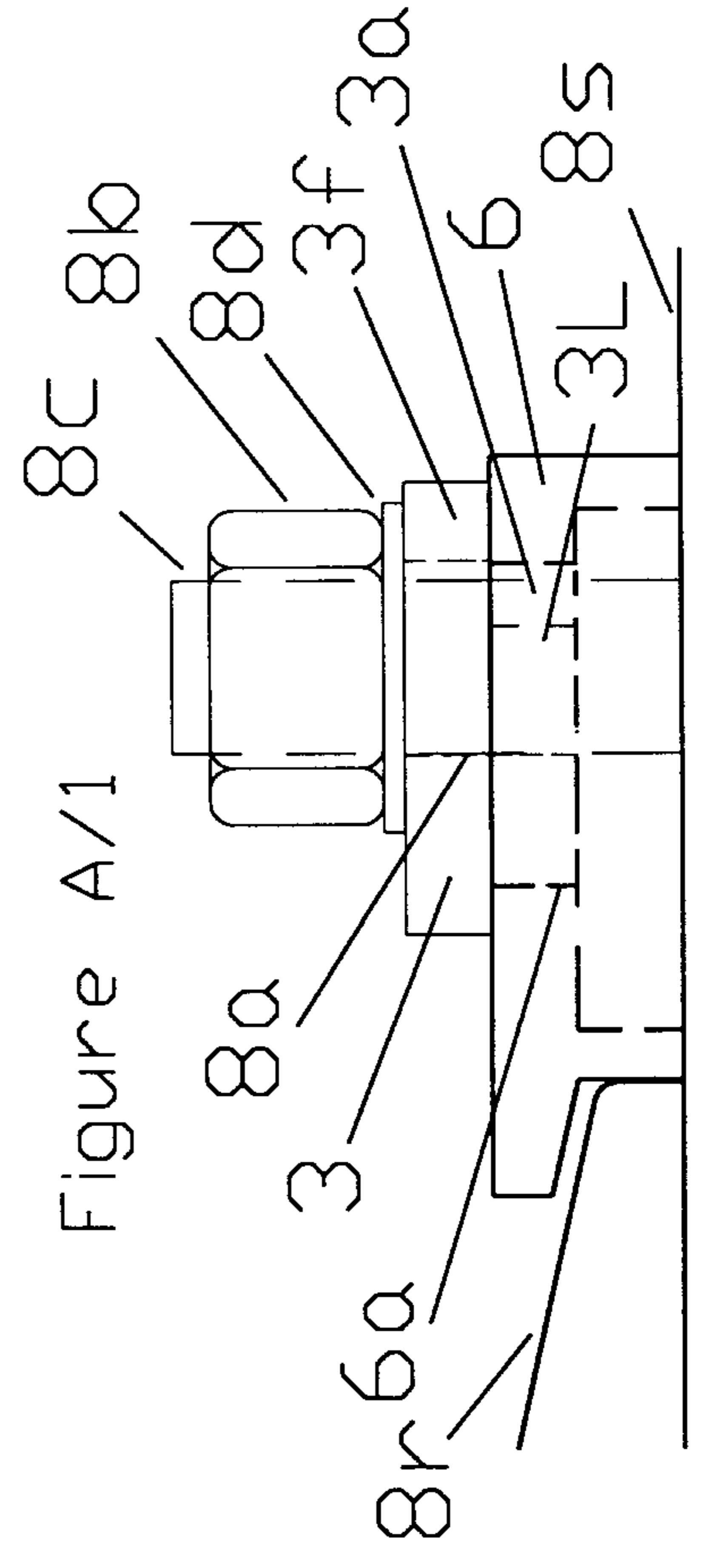
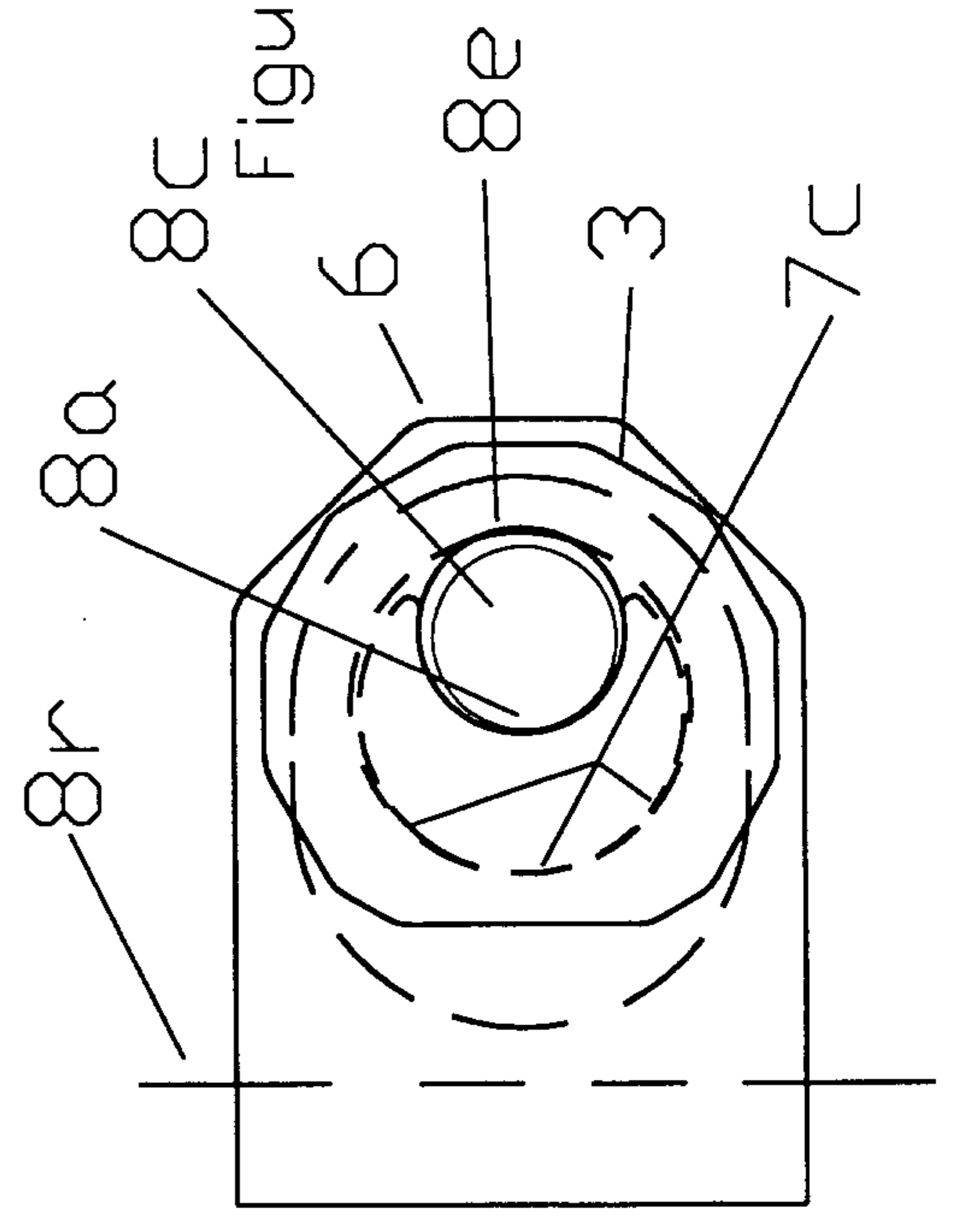
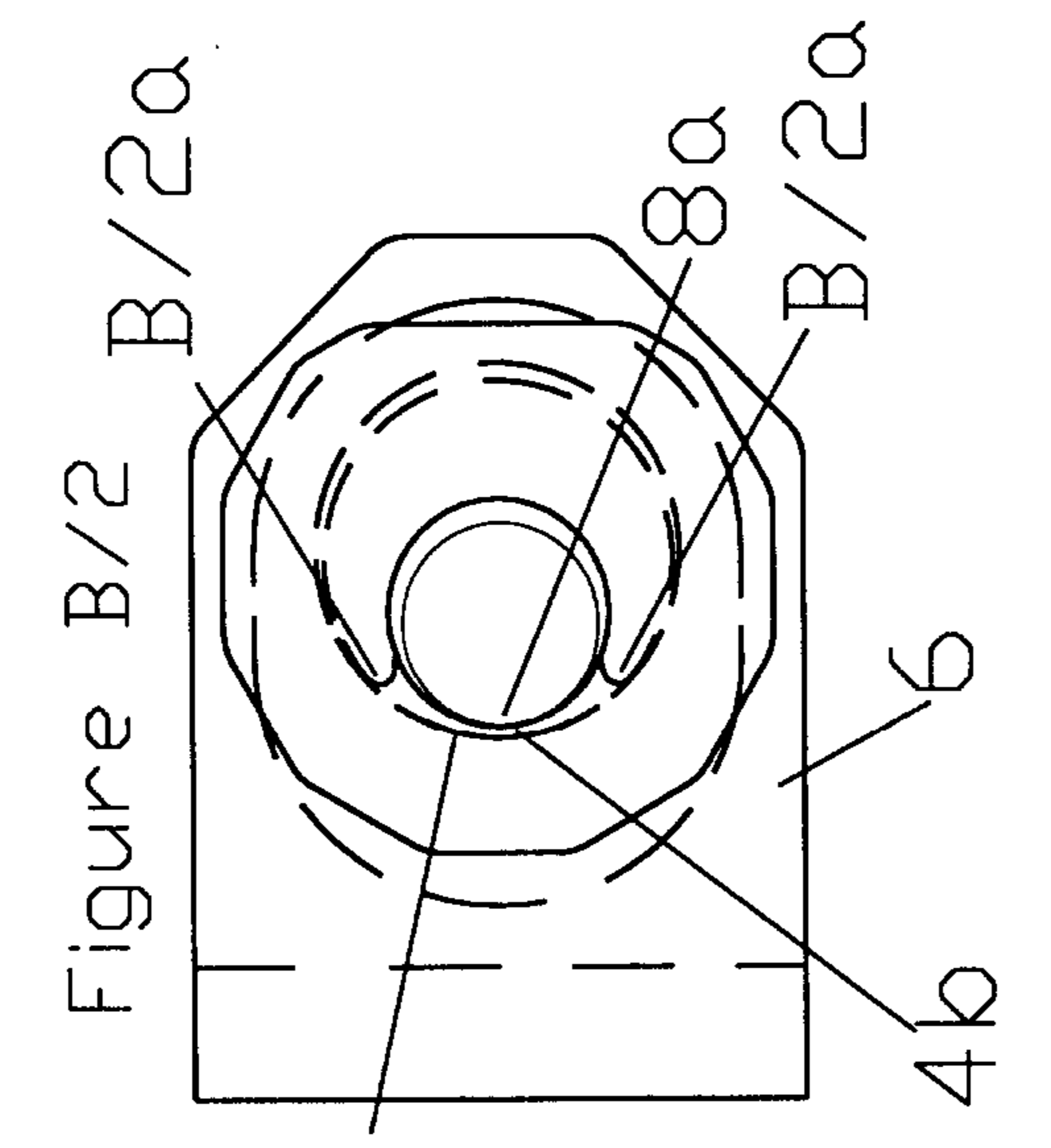
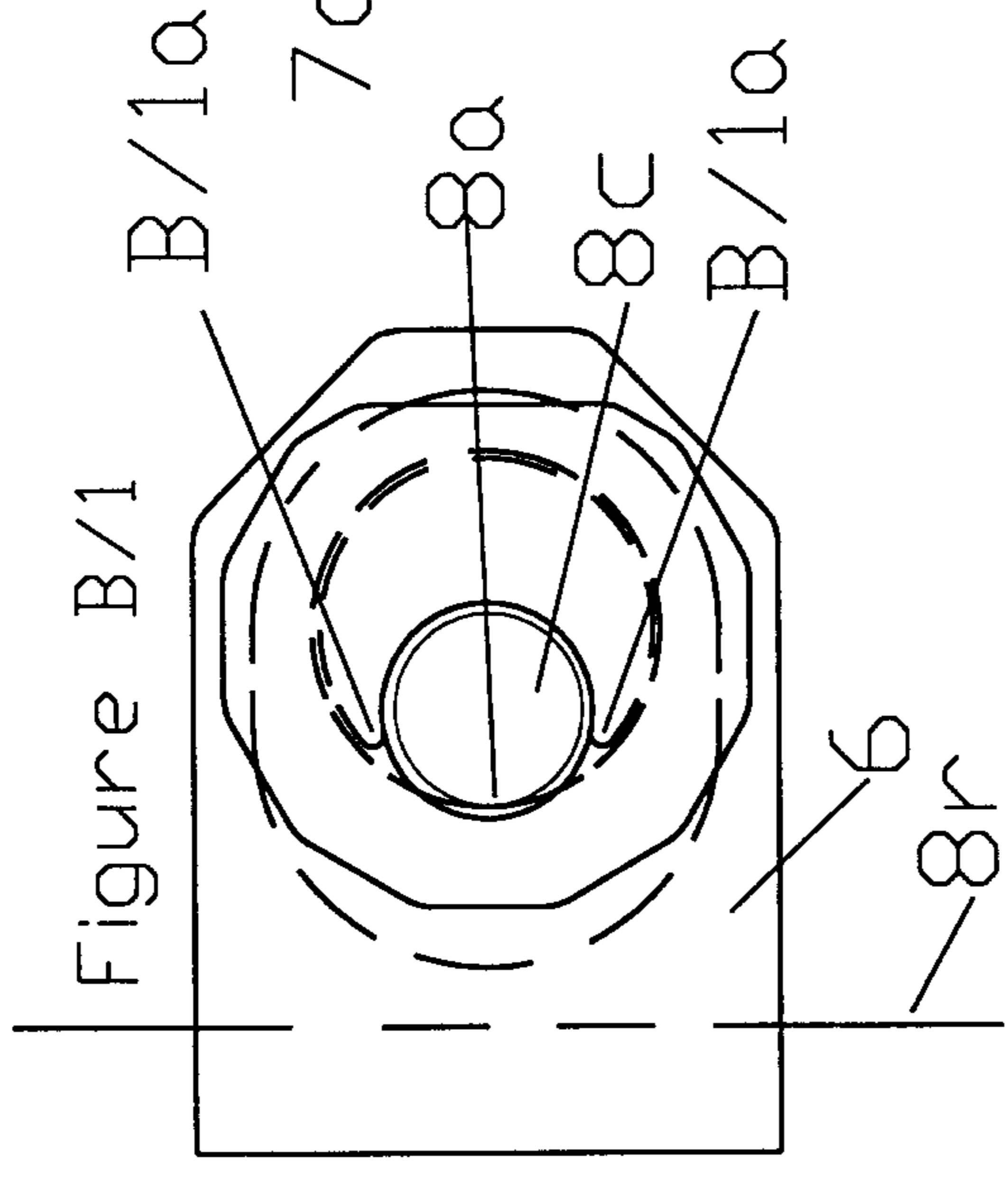
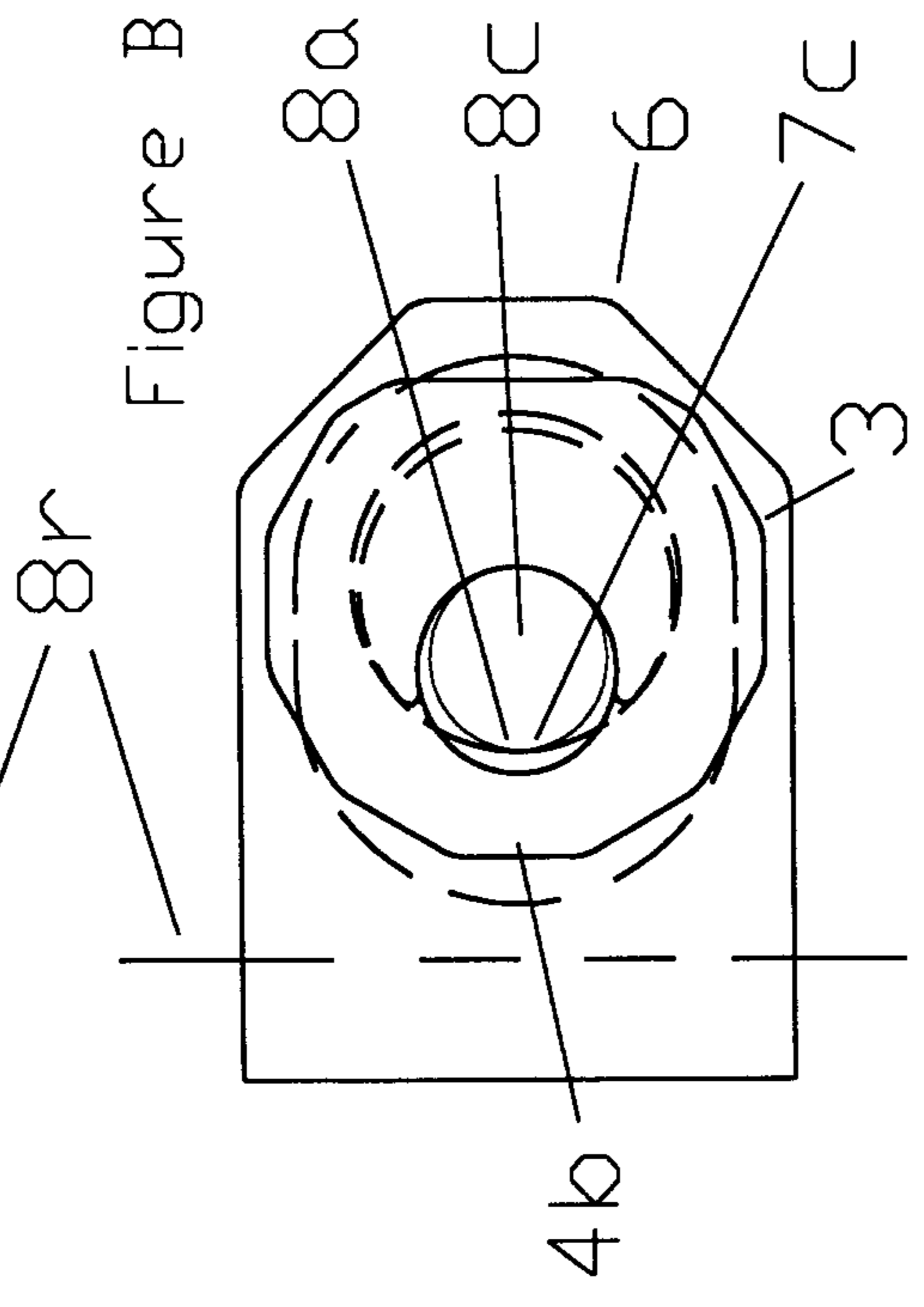
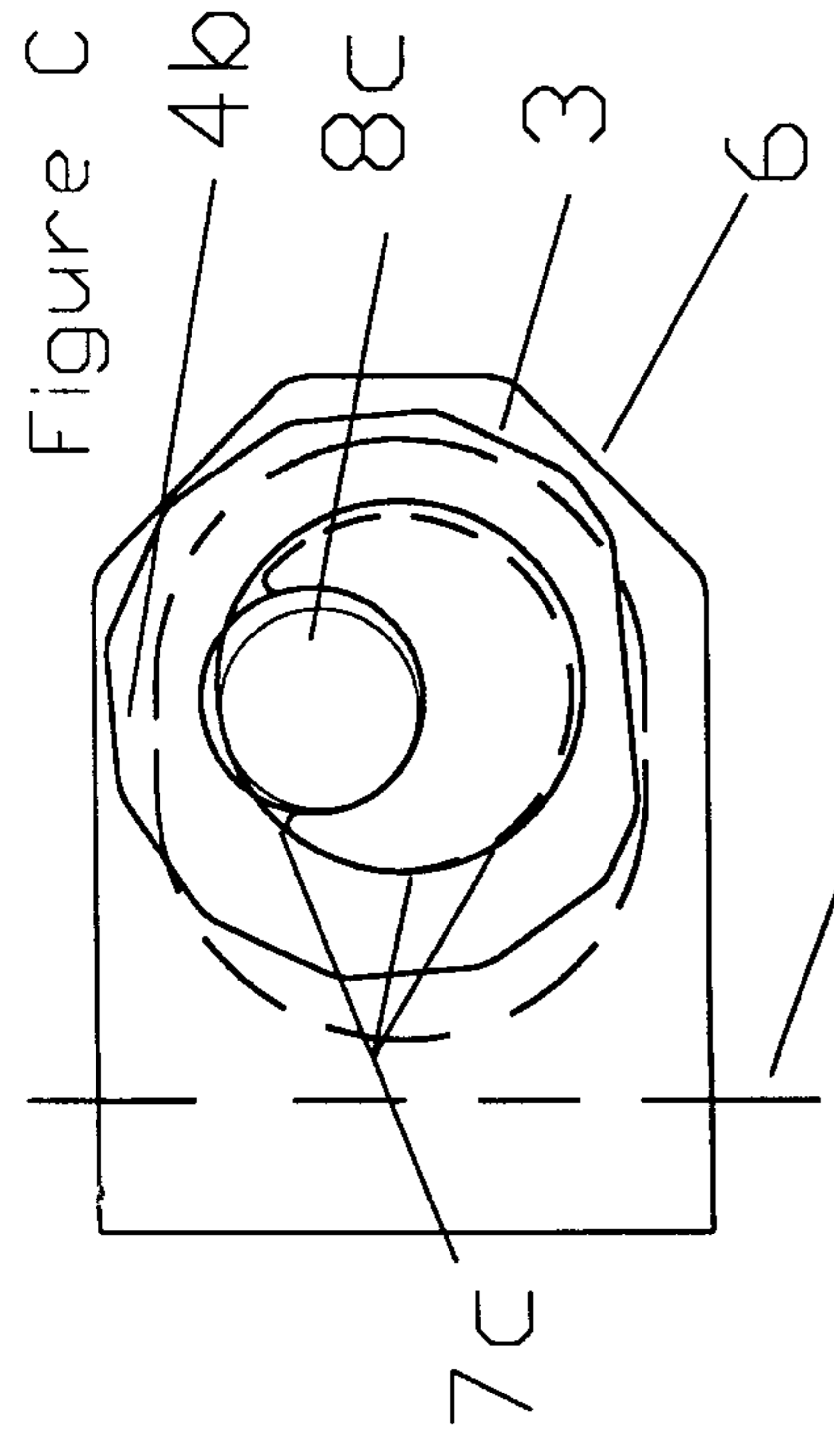

Figure 17

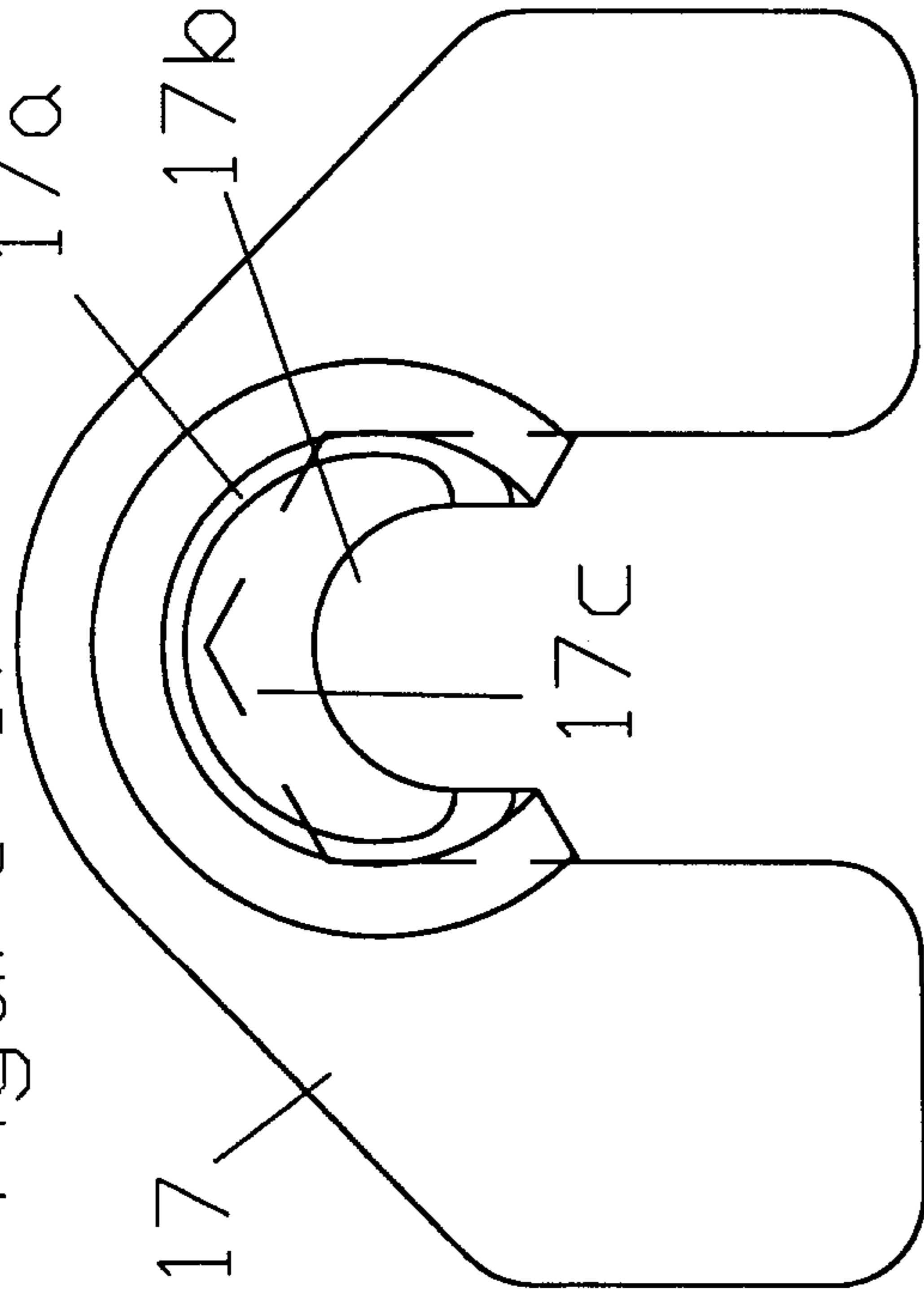

Figure 20

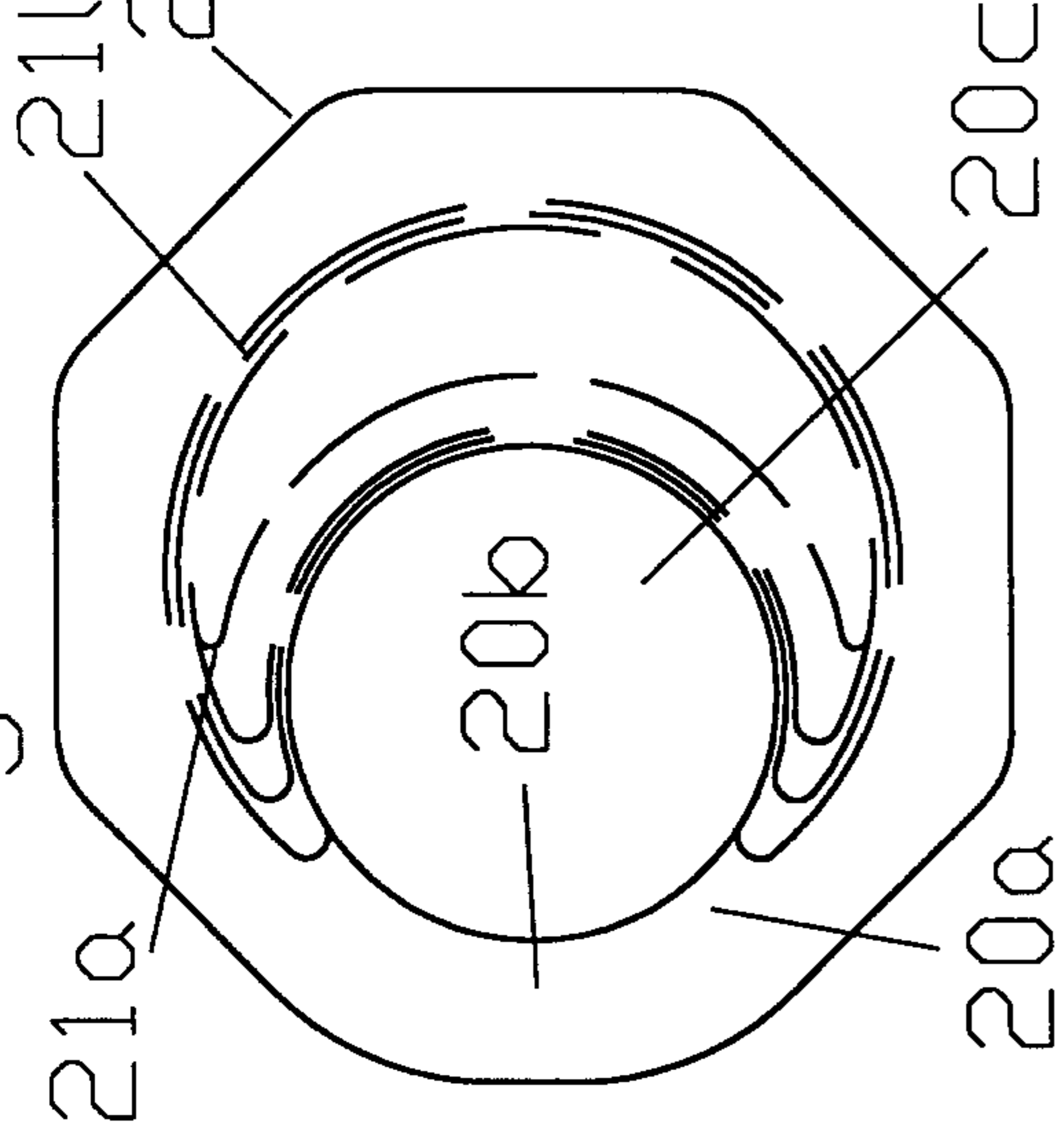

Figure 25

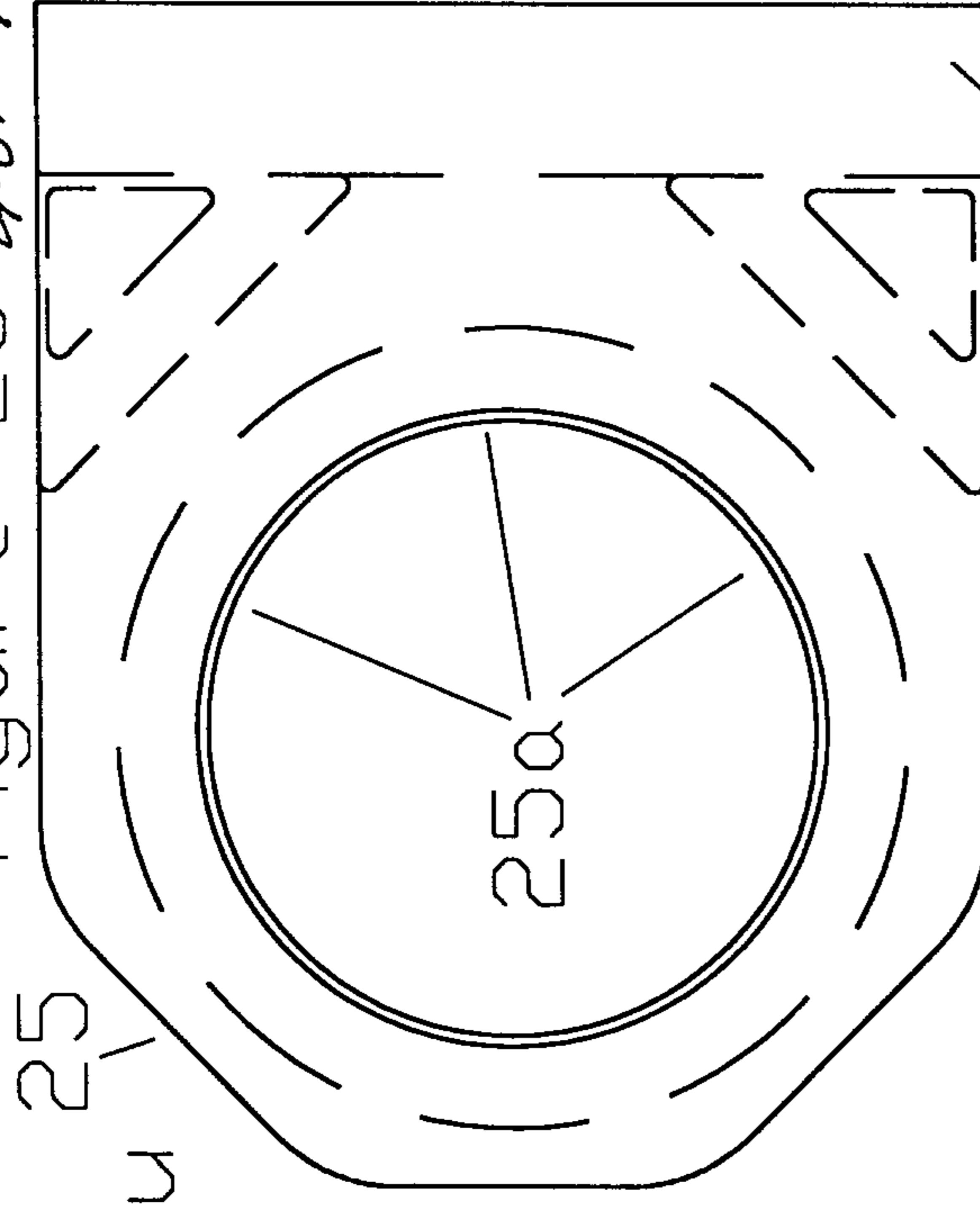

Figure 18

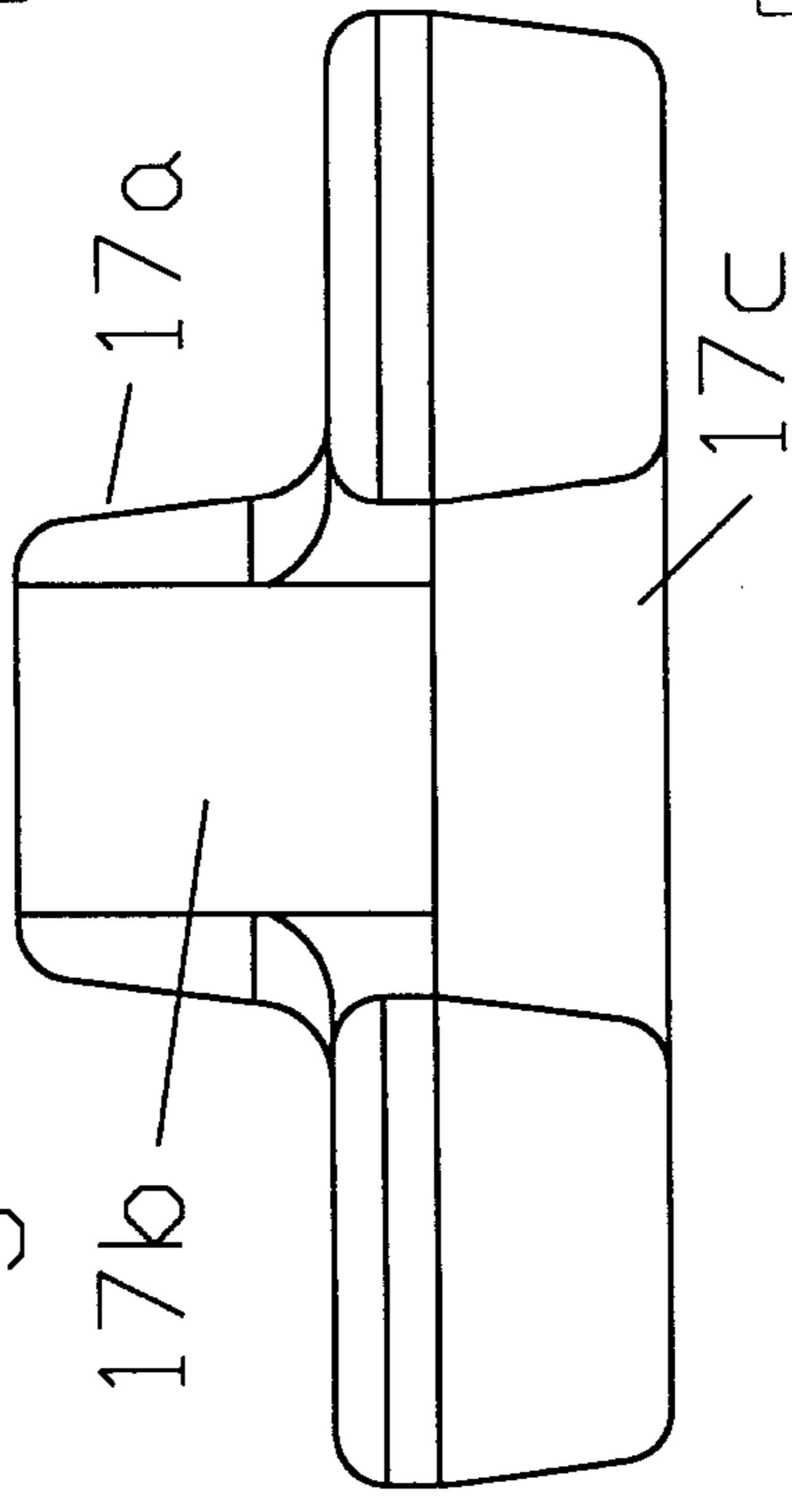

Figure 21

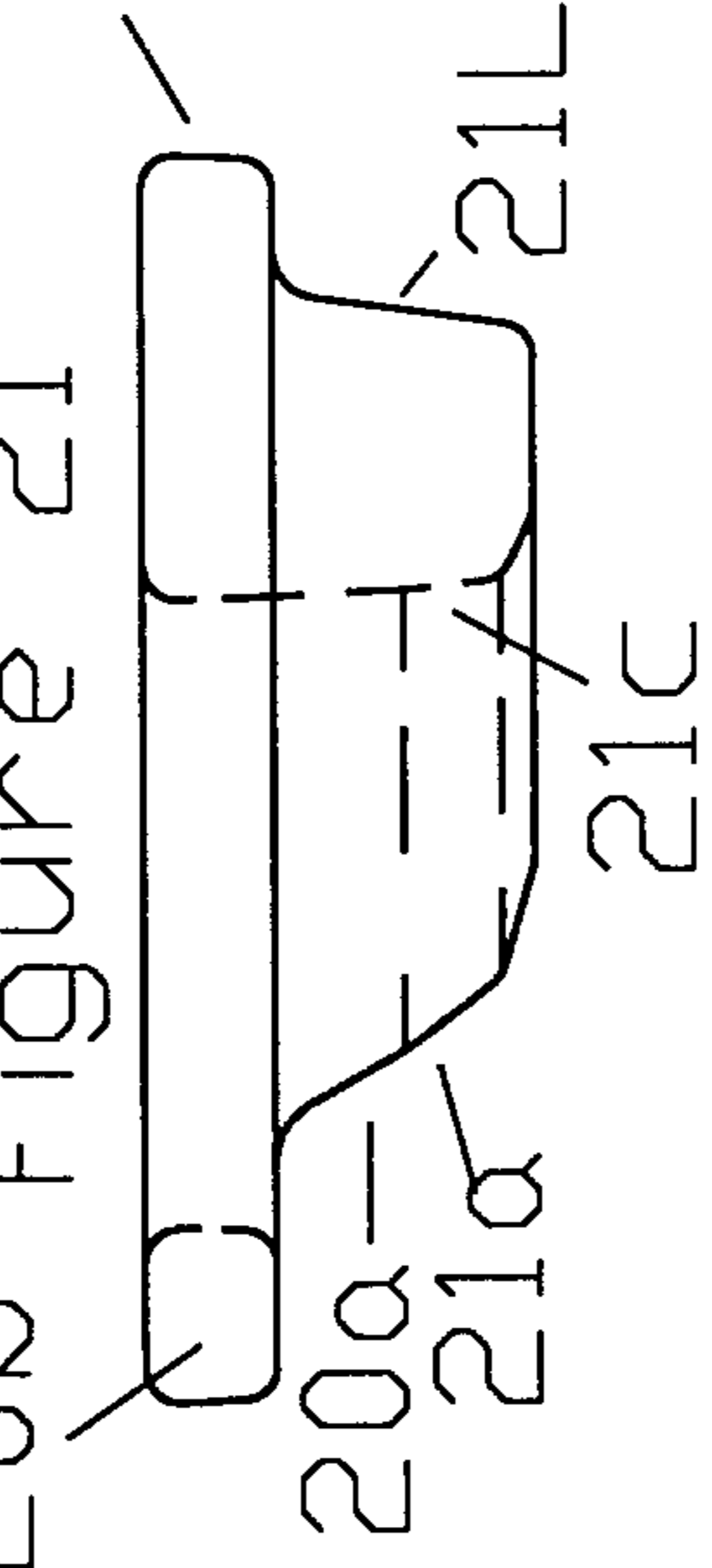

Figure 26

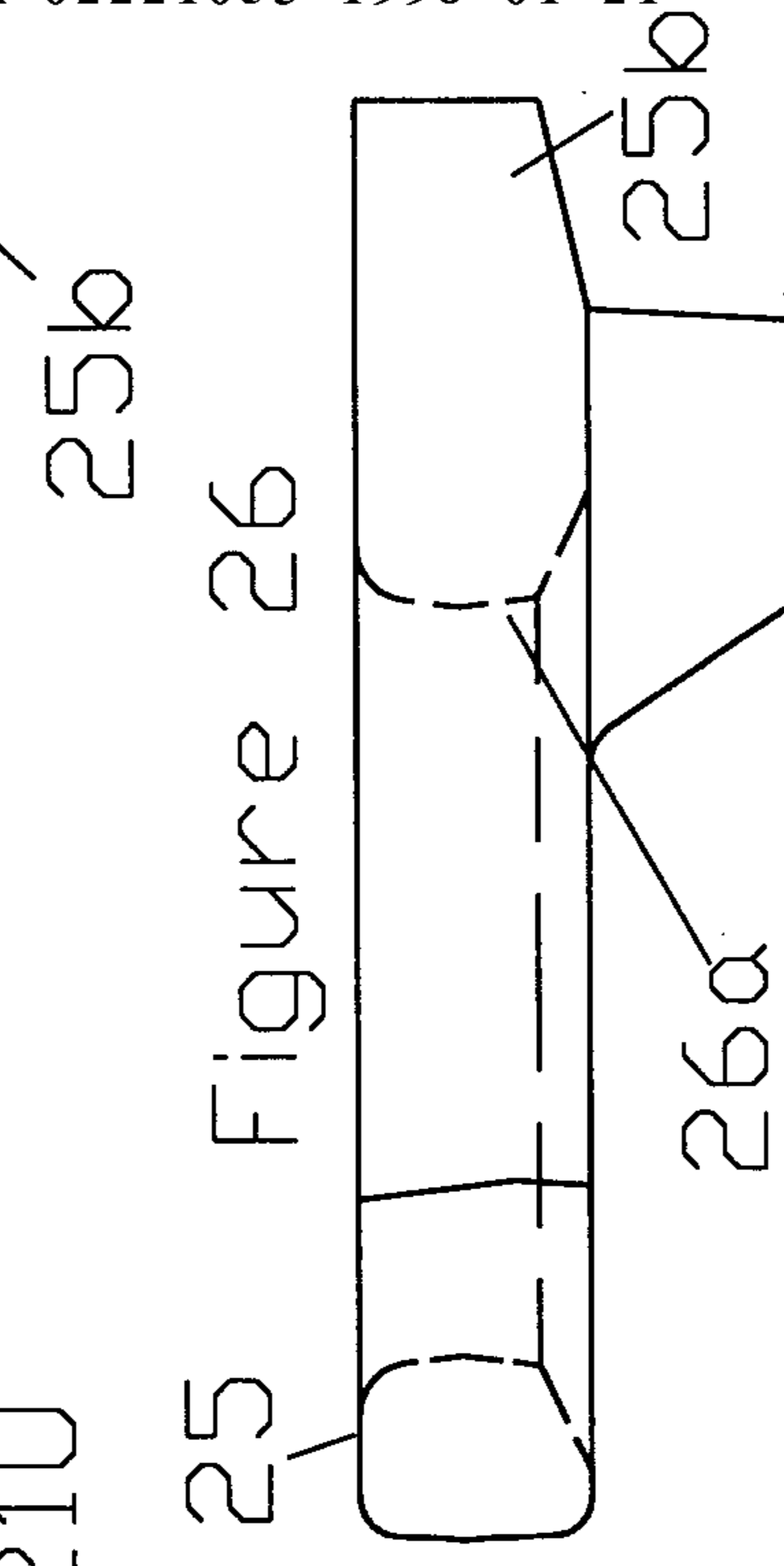

Figure 19

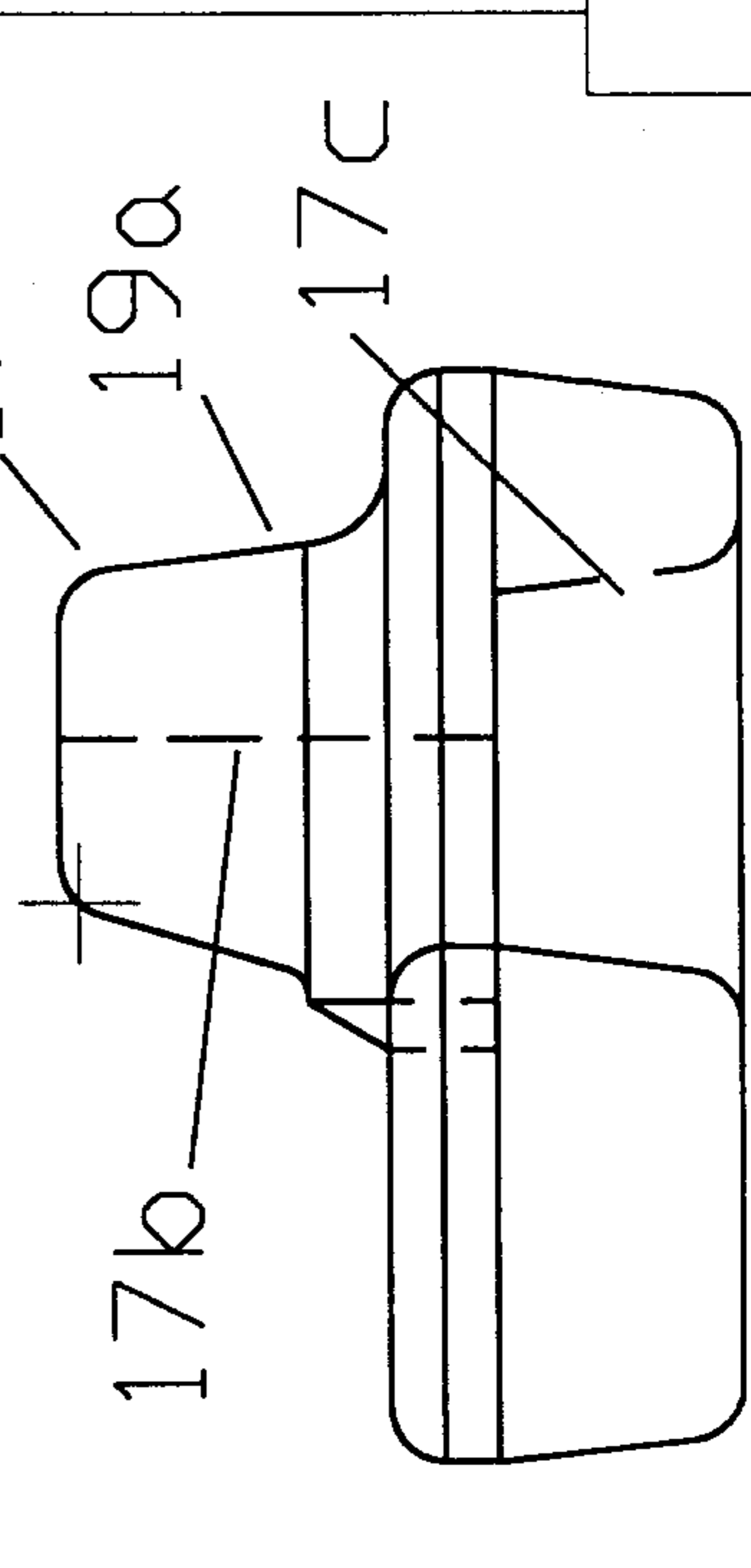

Figure 22



Figure 27

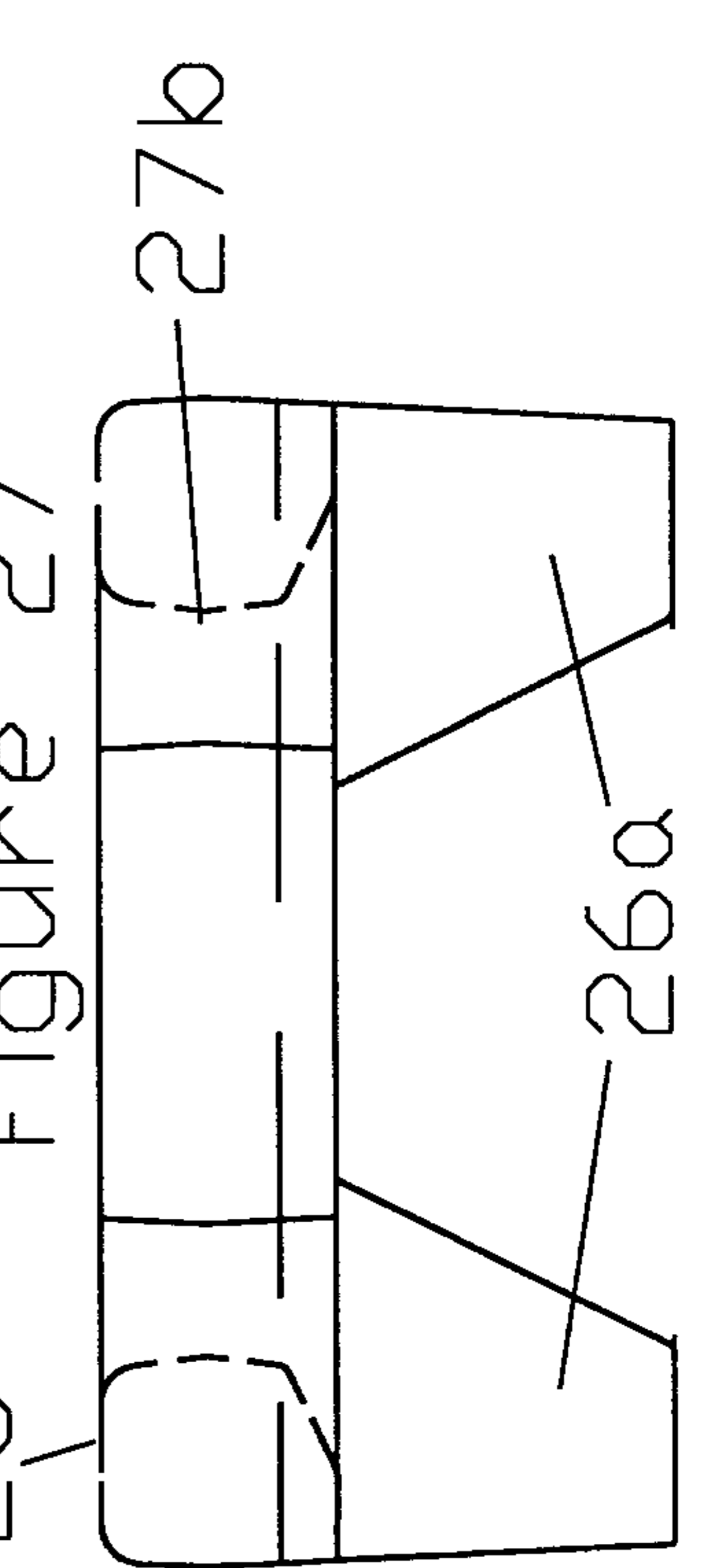

Figure 23

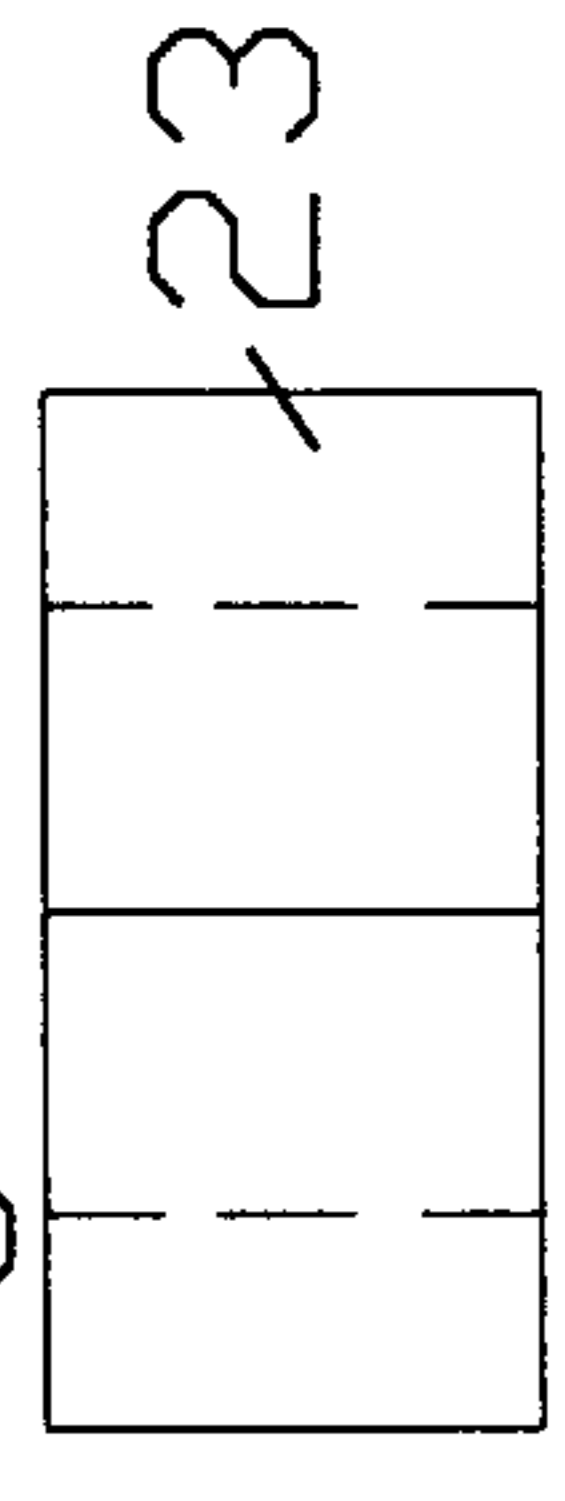

Figure 24

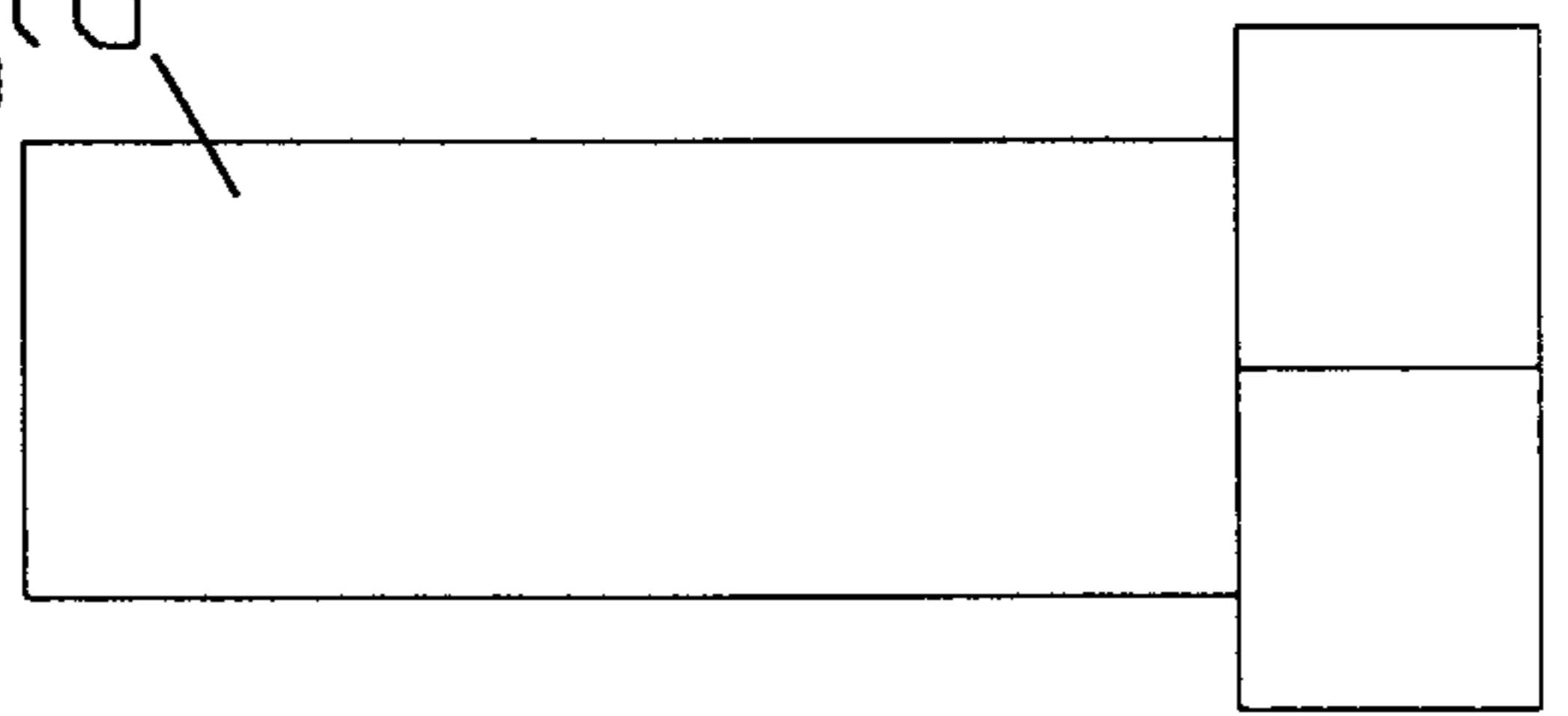
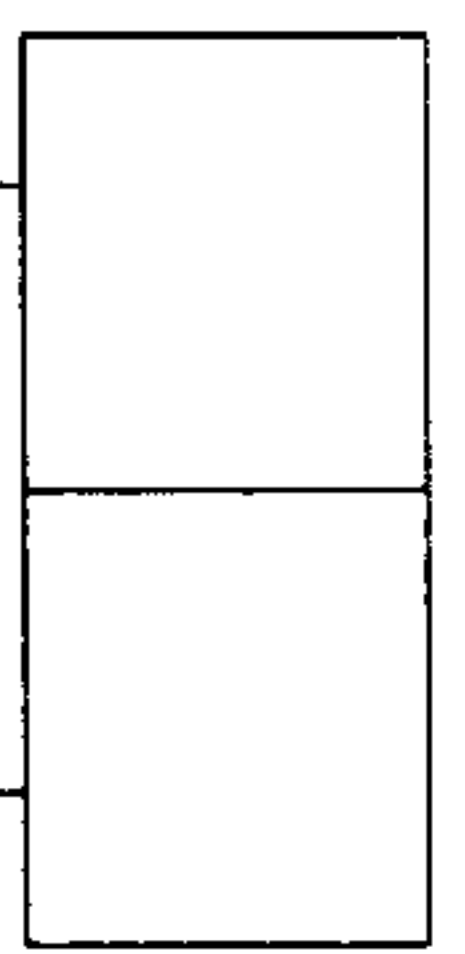

Figure 28



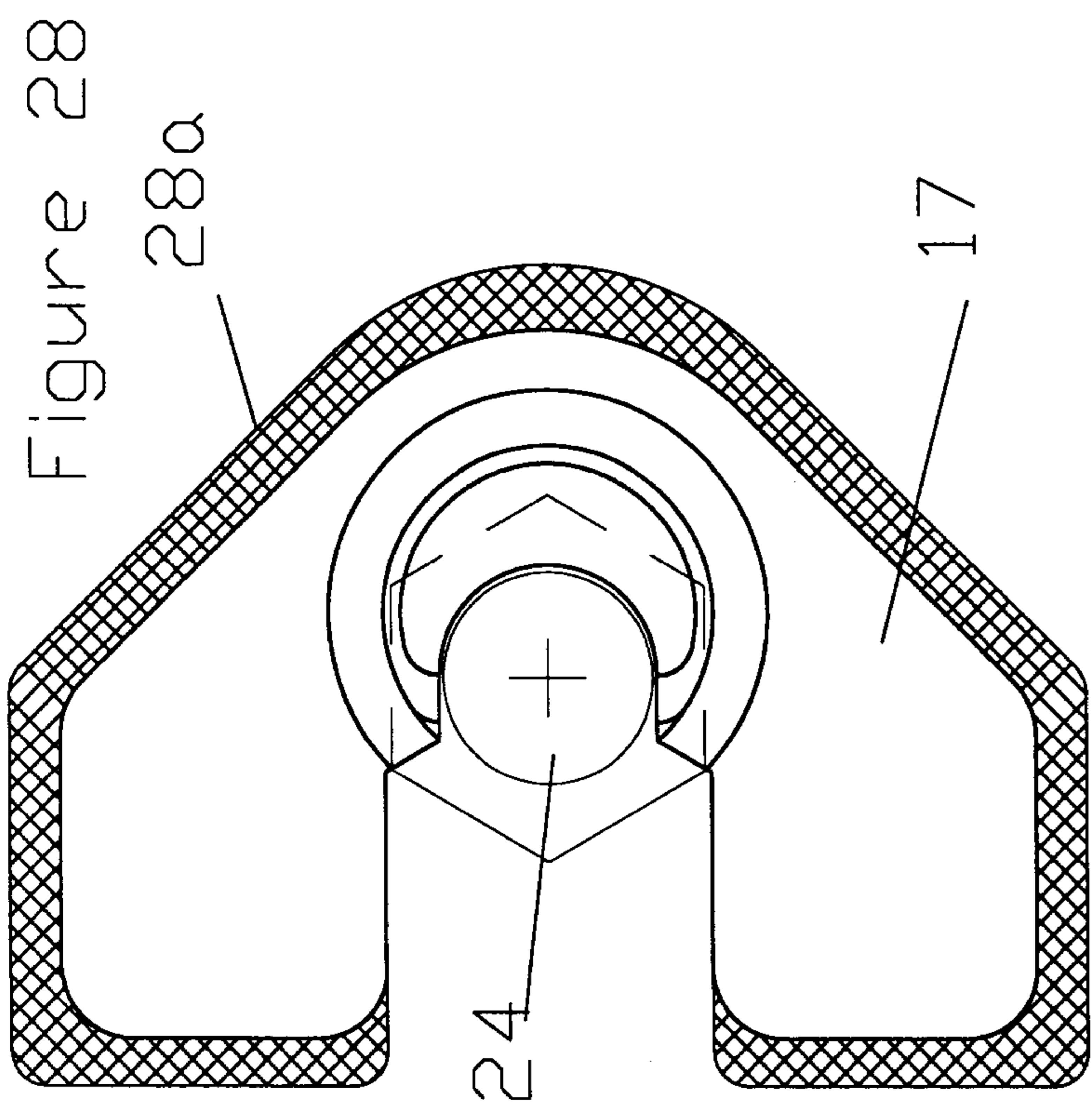

Figure 31

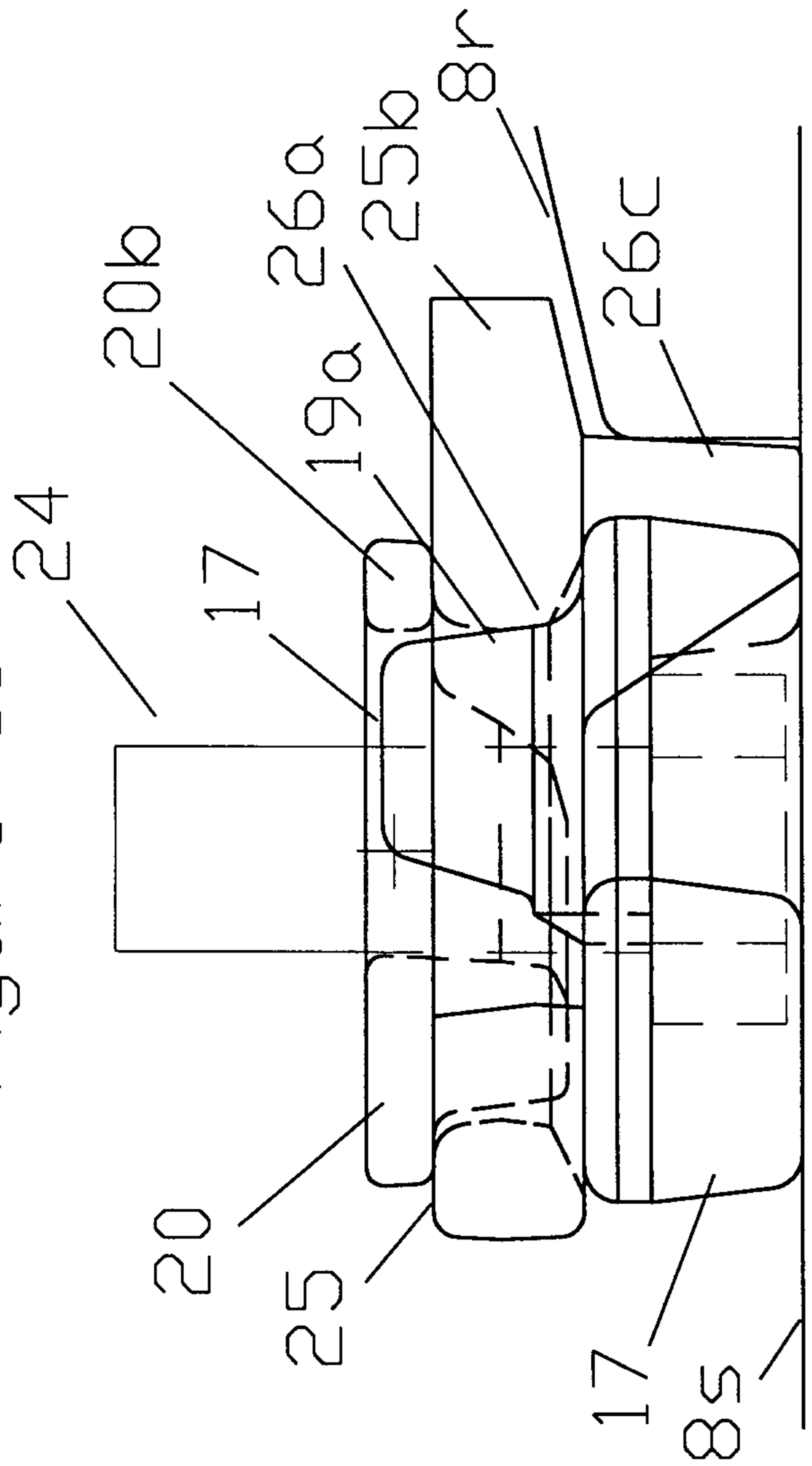

Figure 30

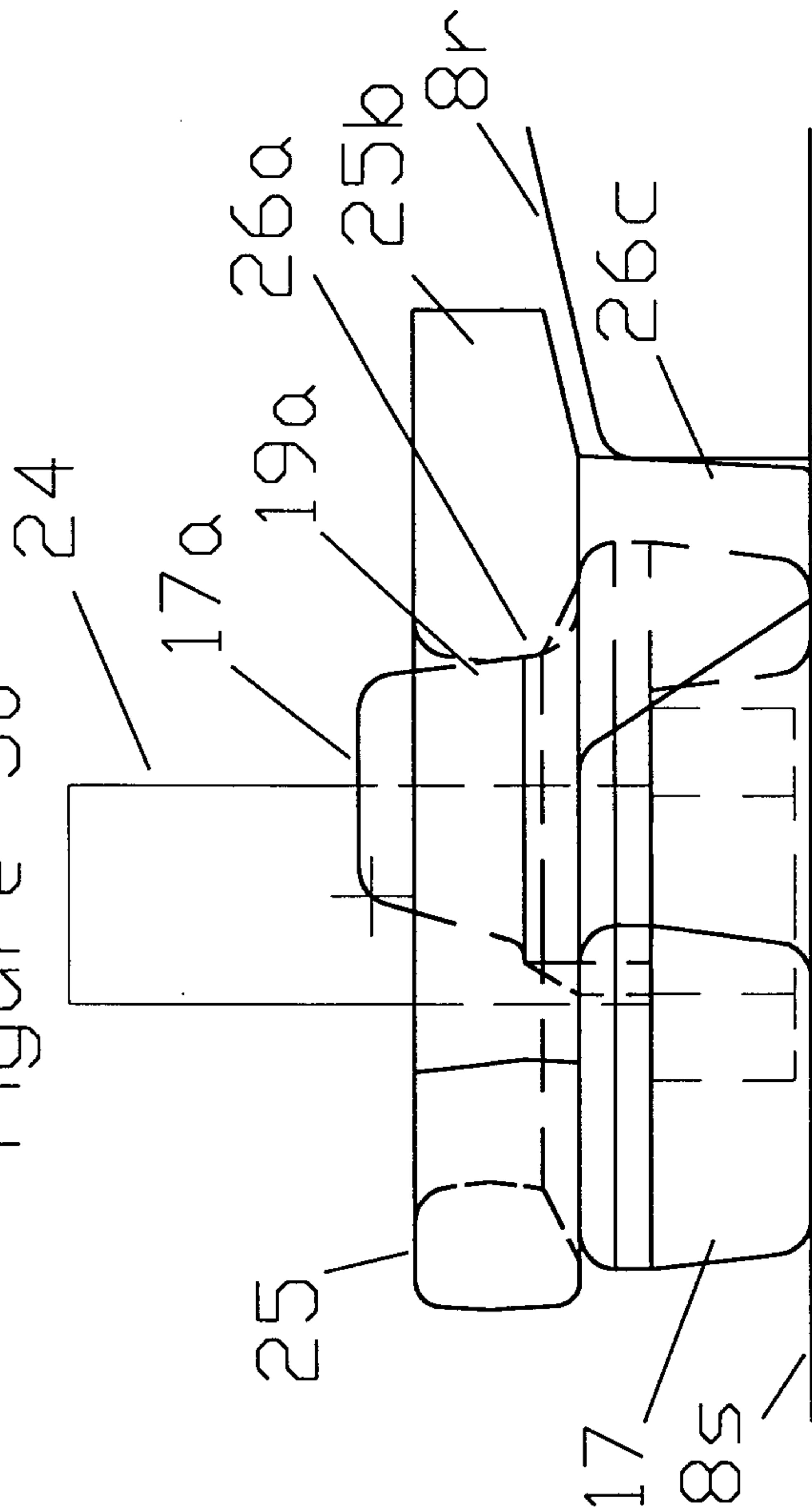

Figure 29

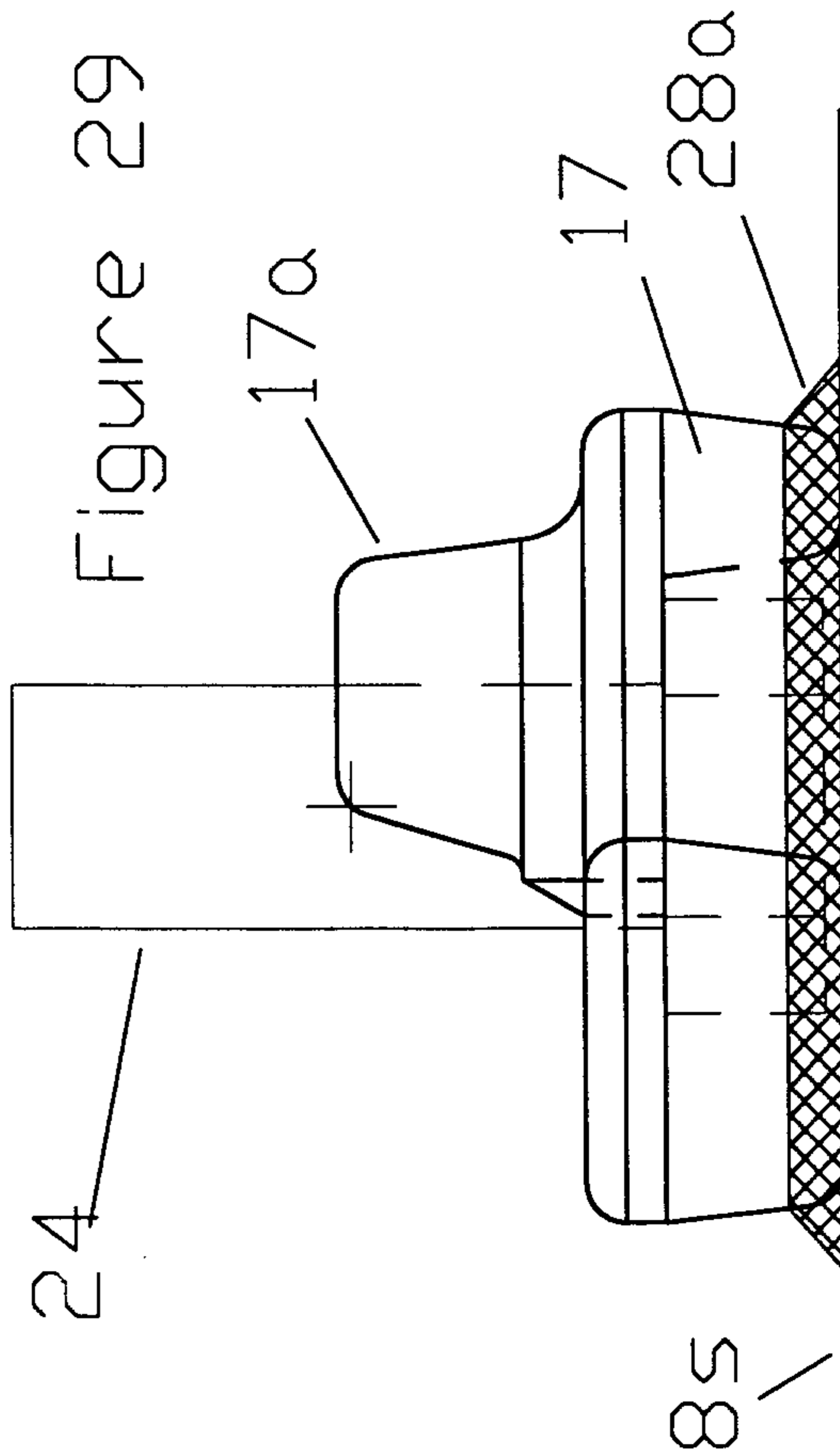

Figure 33

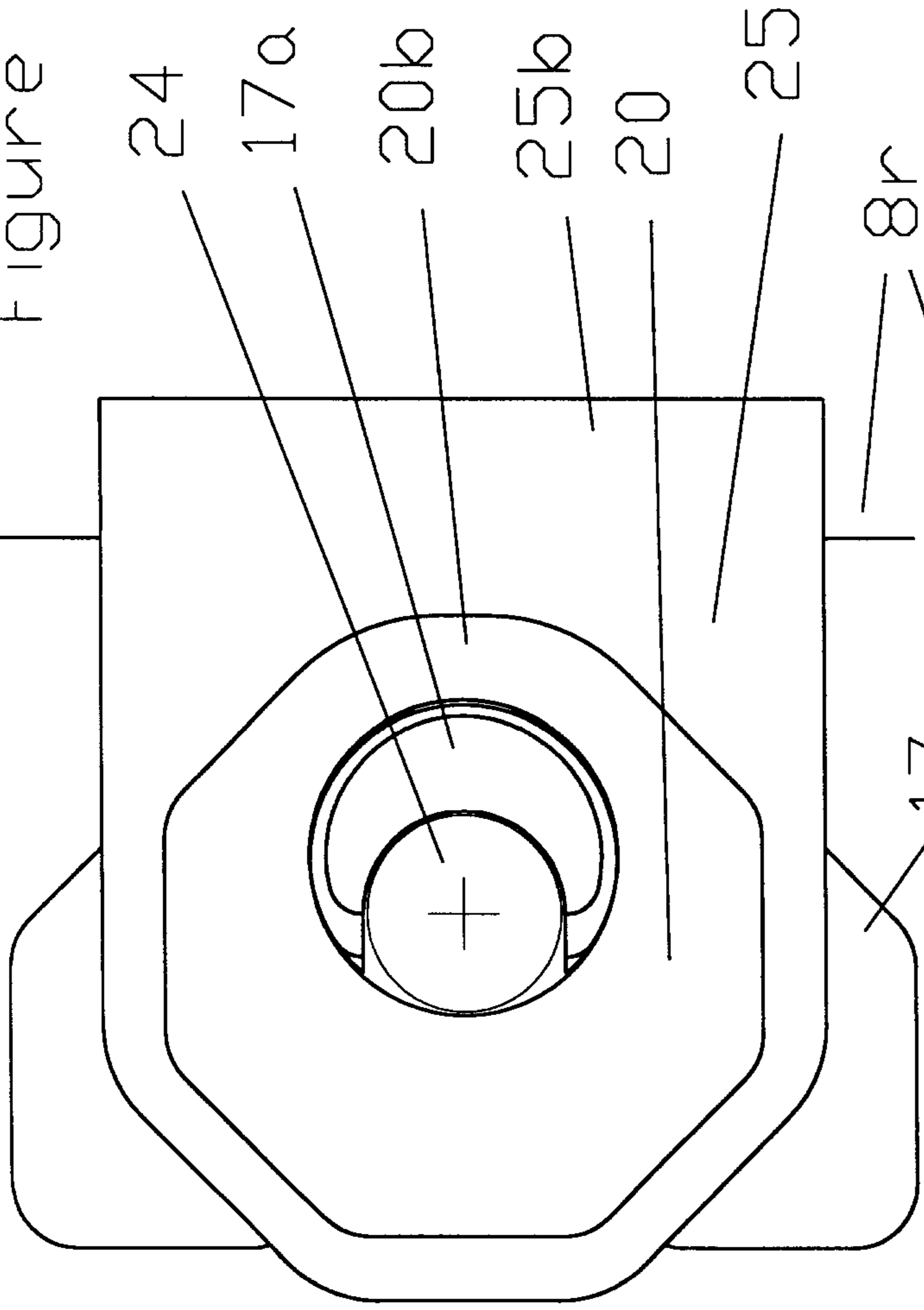

Figure 32

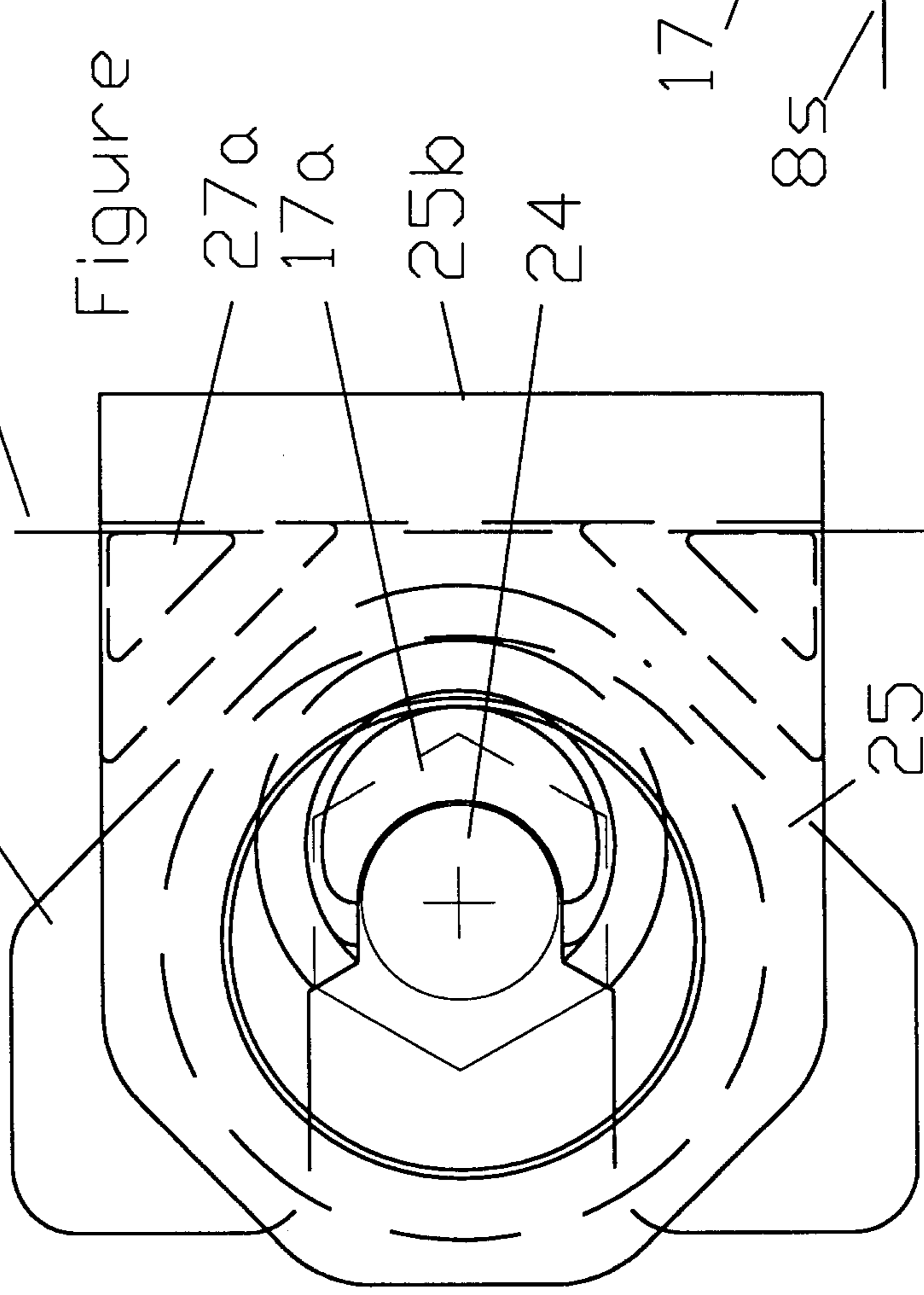

Figure 34

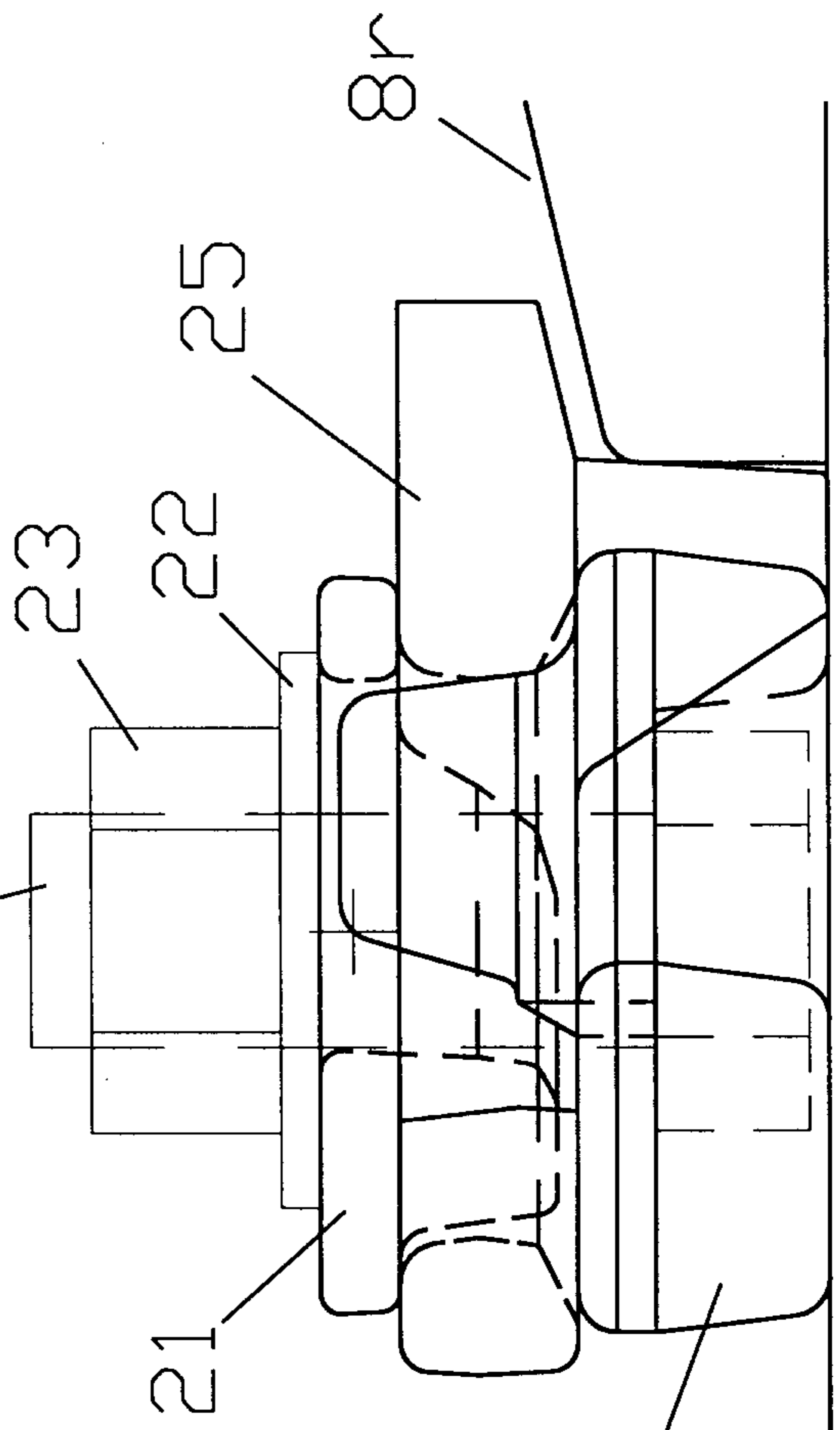

Figure 35

