

No. 654,332.

Patented July 24, 1900.

C. F. SLEIGH.
SPEED GOVERNOR.

(Application filed Nov. 1, 1899.)

(No Model.)

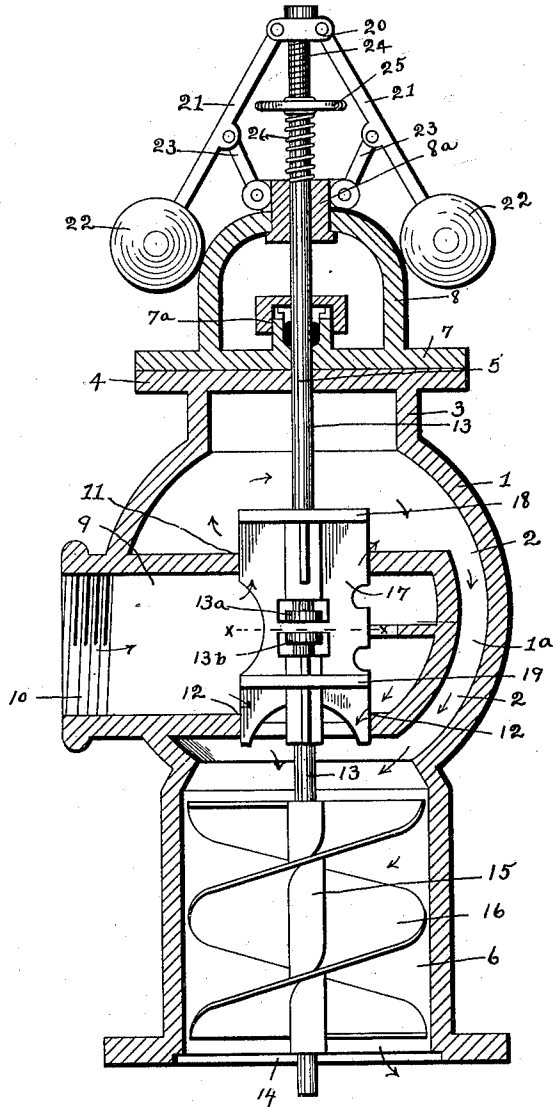

Fig. 1

Fig. 2

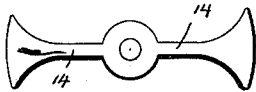
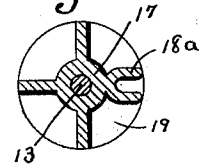

Fig. 3



WITNESSES:

R. L. Hessong.
A. L. Phelps

INVENTOR

Charles F. Sleigh

BY

C. C. Shepherd
ATTORNEY

UNITED STATES PATENT OFFICE.

CHARLES F. SLEIGH, OF NELSONVILLE, OHIO.

SPEED-GOVERNOR.

SPECIFICATION forming part of Letters Patent No. 654,332, dated July 24, 1900.

Application filed November 1, 1899. Serial No. 735,481. (No model.)

To all whom it may concern:

Be it known that I, CHARLES F. SLEIGH, a citizen of the United States, residing at Nelsonville, in the county of Athens and State of Ohio, have invented a certain new and useful Improvement in Speed-Governors, of which the following is a specification.

My invention relates to steam-governors; and the objects of my invention are to provide a governor of this class of superior construction and arrangement of parts, to provide improved means for operating or propelling and regulating the speed of the governor-shaft, to provide an improved governor adapted for use in places where a belt-operated governor cannot conveniently be used to construct my improved governor in a simple and inexpensive form, and to produce other improvements the details of construction of which will be more fully pointed out hereinafter. These objects I accomplish in the manner illustrated in the accompanying drawings, in which—

Figure 1 is a central vertical section of my improved governor-casing. Fig. 2 is a detail plan view of the governor-shaft bearing plate or bar, and Fig. 3 is a sectional view on line *xx* of Fig. 1.

Similar numerals refer to similar parts throughout the several views.

In carrying out my invention I employ a governor casing or body 1, the central portion of which is preferably of the bulb form indicated at 2, and the upper neck extension 3 of which is formed with a top plate 4, having a central shaft-opening 5. The lower end portion of the casing below the bulb 2 is in the form of a downwardly-extending tubular portion or cylinder 6, the lower end of which leads to the engine. Upon the upper side of the casing-plate 4 is secured the horizontal bottom plate 7 of a preferably dome-shaped bearing or shaft-guide 8.

In constructing the central or bulb portion 2 of the governor casing or body I form the same with an internal valve-chamber 9, the latter leading outward through one side of the bulb portion 2 in the form of an internally-threaded nipple 10. This valve-chamber 9 is provided at points vertically opposite each other in its upper and lower sides or walls with valve-openings 11 and 12.

13 represents a central vertical governor-shaft which extends centrally through the casing above described, the lower end of said shaft having a bearing in the central portion of a cross-bar 14, which is secured in the lower end of the casing extension 6. Upon this shaft and within said casing extension 6 is secured by feather or keyed the central tubular or sleeve portion 15 of a spiral or propeller 16, the lower end of the central tubular portion of said propeller being adapted to bear upon the cross-bar 14.

17 represents the governor-valve, which is carried vertically on the shaft 13, said shaft passing centrally and loosely therethrough, said valve, however, being prevented from independent vertical movement on the shaft by the employment of separated shaft-collars 13^a and 13^b, between which the central portion of the valve 17 is journaled. The upper portion of the valve 17 is adapted to project through the valve-casing opening 11, and the upper end of said valve is provided with a closing head or shoulder 18, adapted when said valve is in its lower position to close said opening 11. In its lower portion the valve 13 is also provided with a closing-shoulder, which is indicated at 19, which when the valve is in its lowest position may close the valve-opening 12. The upper portion of the shaft 13 passes through the shaft-opening 5 in the top plate 4, through a corresponding opening in the bearing base-plate 7, and through a suitable steam-tight packing-box 7^a, thence through a vertical bearing-sleeve 8^a, which is rotatably supported in the upper end of the dome 8. On the upper end of the shaft is secured a governor-head block 20, with the ends of which are pivotally connected the upper ends of the usual downwardly-extending and outwardly-inclined governor-arms 21, said governor-arms carrying suitable weights or balls 22 on their lower ends and being jointly connected with laterally-projecting ears of the bearing-sleeve 8^a through the medium of the usual connecting-bars 23. The upper portion of the shaft 13 is, as indicated at 24, threaded, said threaded portion having thereon an internally-threaded hand-wheel 25. Between this hand-wheel and the upper end of the sleeve 8^a I employ a coiled spring 26. In order to prevent rotation of the valve on

the shaft 13, I have, as indicated more clearly in Fig. 3 of the drawings, provided the central portion of said valve with a recessed projection 17^a, with which is adapted to engage loosely a projecting arm 9^a of the valve-casing 9.

In operation the steam which enters the mouth 10 of the valve-chamber 9 following the direction of the arrows indicated in Fig. 1 reaches the propeller-chamber 6 by passing through the valve-opening 11, thence through the passage 1^a, between the valve-chamber and the wall of the casing-body 1, and also by passing directly from the valve-casing through the valve-opening 12 into said propeller-chamber. In this manner the blades of the spiral or propeller 16 are subjected to the incoming steam-pressure and a rotary motion thereby imparted to said propeller. Owing to the fact that this propeller is keyed or feathered upon the shaft 13, a corresponding rotary motion of the latter and the governor-head will be attained and the shaft be permitted to slide through the propeller. As is common in other forms of governors, the increase over a predetermined speed of the governor-shaft will result in a corresponding raising of the balls 22 and in a consequent downward movement of the shaft 13. It is obvious that in the construction described this downward movement of said shaft may result in partially or wholly closing the valve-openings 11 and 12 through the downward movement of the valve, thereby automatically regulating the entrance of the steam through said valve-openings and decreasing the speed as required. It is evident that in this manner the raising and lowering of the governor-balls will result in a closing and opening action of the valve and that the speed of the spiral or propeller 16 will by direct contact with the steam be governed by

the volume or pressure of steam which the position of the valve permits to pass through the valve-opening. It is obvious that the governor-shaft and valve may be set at the desired elevation, according to the speed required by a proper rotation of the hand-wheel 25.

From the construction and operation above described it will be seen that a simple, reliable, and effective governor-operating mechanism is provided by which the speed of the engine will be regulated and equalized automatically, and it will also be observed that said governor-operating mechanism may be produced in an inexpensive manner.

Having now fully described my invention, what I claim, and desire to secure by Letters Patent, is—

1. In a speed-governor, the combination with a casing and a valve and governor controlling shaft rotatably mounted and vertically movable therein, of a propeller feathered on said shaft said propeller being arranged between the valve and engine and adapted to be subjected to the pressure of steam which passes said valve, substantially as set forth.

2. In a speed-governor, the combination with a casing and a valve-chamber therein having valve-openings, a rotary and vertically-movable governor-shaft having thereon ball-carrying arms and a valve on said shaft, a propeller-chamber below said valve-chamber between the valve and engine and a passage connecting the latter with the space above the valve-chamber, of a spiral propeller carried on said shaft within said propeller-chamber, substantially as set forth.

CHARLES F. SLEIGH.

In presence of—

C. C. SHEPHERD,
A. L. PHELPS.