

(19) World Intellectual Property Organization  
International Bureau



(43) International Publication Date  
20 May 2010 (20.05.2010)

PCT

(10) International Publication Number  
WO 2010/056745 A1

- (51) International Patent Classification:  
A61B 18/14 (2006.01)
- (21) International Application Number:  
PCT/US2009/064027
- (22) International Filing Date:  
11 November 2009 (11.11.2009)
- (25) Filing Language: English
- (26) Publication Language: English
- (30) Priority Data:  
61/115,344 17 November 2008 (17.11.2008) US
- (71) Applicant (for all designated States except US): **MIN-NOW MEDICAL, INC.** [US/US]; 10911 Technology Place, San Diego, CA 92127 (US).
- (72) Inventors; and  
(75) Inventors/Applicants (for US only): **GUSTUS, Rolfe, Tyson** [US/US]; 10911 Technology Place, San Diego, CA 92127 (US). **KUNSTMANAS, Linas** [US/US]; 10911 Technology Place, San Diego, CA 92127 (US). **BLANCK, Arthur, G.** [US/US]; 10911 Technology Place, San Diego, CA 92127 (US).
- (74) Agents: **BARRISH, Mark, D.** et al.; Townsend And Townsend And Crew LLP, Two Embarcadero Center, 8th Floor, San Francisco, CA 94111-3834 (US).

- (81) Designated States (unless otherwise indicated, for every kind of national protection available): AE, AG, AL, AM, AO, AT, AU, AZ, BA, BB, BG, BH, BR, BW, BY, BZ, CA, CH, CL, CN, CO, CR, CU, CZ, DE, DK, DM, DO, DZ, EC, EE, EG, ES, FI, GB, GD, GE, GH, GM, GT, HN, HR, HU, ID, IL, IN, IS, JP, KE, KG, KM, KN, KP, KR, KZ, LA, LC, LK, LR, LS, LT, LU, LY, MA, MD, ME, MG, MK, MN, MW, MX, MY, MZ, NA, NG, NI, NO, NZ, OM, PE, PG, PH, PL, PT, RO, RS, RU, SC, SD, SE, SG, SK, SL, SM, ST, SV, SY, TJ, TM, TN, TR, TT, TZ, UA, UG, US, UZ, VC, VN, ZA, ZM, ZW.
- (84) Designated States (unless otherwise indicated, for every kind of regional protection available): ARIPO (BW, GH, GM, KE, LS, MW, MZ, NA, SD, SL, SZ, TZ, UG, ZM, ZW), Eurasian (AM, AZ, BY, KG, KZ, MD, RU, TJ, TM), European (AT, BE, BG, CH, CY, CZ, DE, DK, EE, ES, FI, FR, GB, GR, HR, HU, IE, IS, IT, LT, LU, LV, MC, MK, MT, NL, NO, PL, PT, RO, SE, SI, SK, SM, TR), OAPI (BF, BJ, CF, CG, CI, CM, GA, GN, GQ, GW, ML, MR, NE, SN, TD, TG).

Published:  
— with international search report (Art. 21(3))

(54) Title: SELECTIVE ACCUMULATION OF ENERGY WITH OR WITHOUT KNOWLEDGE OF TISSUE TOPOGRAPHY

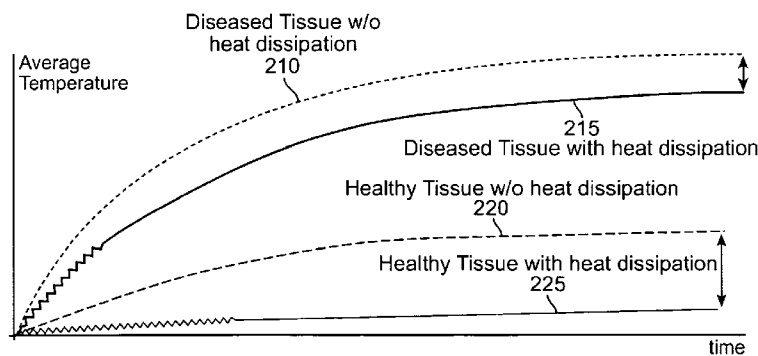

FIG. 5

(57) Abstract: Methods and systems for heating a body tissue region adjacent a body lumen with diseased and healthy portions using selective accumulation of energy in the artery tissue with or without knowledge of tissue topography. The method includes positioning an energy delivery portion of a catheter body within the lumen adjacent the body tissue region to be heated, determining a pulse characteristic in response to a thermal property of a first tissue type and applying pulsed energy with the pulse characteristic from the energy delivery portion so as to therapeutically treat the second tissue type within the body tissue region by drawing heat from the first tissue type at a rate that avoids significant thermal damage to the first tissue type while building-up heat in the second tissue type.

WO 2010/056745 A1

## SELECTIVE ACCUMULATION OF ENERGY WITH OR WITHOUT KNOWLEDGE OF TISSUE TOPOGRAPHY

### CROSS-REFERENCES TO RELATED APPLICATIONS

5 [0001] The present application claims the benefit under 35 USC 119(e) of US Provisional Application No. 61/115,344 filed November 17, 2008; the full disclosure of which is incorporated herein by reference in its entirety.

[0002] This application is related to U.S. Application No. 11/975,474, filed on October 18, 2007, entitled "Inducing Desirable Temperature Effects on Body Tissue"; U.S. Application  
10 No. 11/975,383, filed on October 18, 2007, and entitled "System for Inducing Desirable Temperature Effects on Body Tissues", U.S. Patent Application No. 11/122,263, filed on May 3, 2005, entitled "Imaging and Eccentric Atherosclerotic Material Laser remodeling and/or Ablation Catheter", and U.S. Provisional Application No. 61/099,155, filed on  
15 September 22, 2008, entitled "Inducing Desirable Temperature Effects On Body Tissue Using Alternate Energy Sources", the full disclosures of which are incorporated herein by reference.

### STATEMENT AS TO RIGHTS TO INVENTIONS MADE UNDER FEDERALLY SPONSORED RESEARCH AND DEVELOPMENT

20 [0003] NOT APPLICABLE

### BACKGROUND OF THE INVENTION

[0004] The present invention is generally related to medical devices, systems, and methods for heating body tissue. In exemplary embodiments, the invention provides catheter-based  
25 treatment for heating body tissue with energy that selectively accumulates in a desired type of tissue, particularly diseased tissue, with or without knowing the tissue topography a-priori.

[0005] Balloon angioplasty and other catheters often are used to open arteries that have been narrowed due to atherosclerotic disease. The trauma associated with balloon dilation can impose significant injury, so that the benefits of balloon dilation may be limited in time.  
30 Stents are commonly used to extend the beneficial opening of the blood vessel. Restenosis or

a subsequent narrowing of the body lumen after stenting has occurred in a significant number of cases.

[0006] More recently, drug coated stents (such as Johnson and Johnson's Cypher™ stent, the associated drug comprising Sirolimus™) have demonstrated a markedly reduced  
5 restenosis rate, and others are developing and commercializing alternative drug eluting stents. In addition, work has also been initiated with systemic drug delivery (intravenous or oral) which may also improve the procedural angioplasty success rates.

[0007] While drug eluting stents appear to offer significant promise for treatment of atherosclerosis in many patients, there remain many cases where stents either cannot be used  
10 or present significant disadvantages. Generally, stenting leaves an implant in the body. Such implants can present risks, including mechanical fatigue, corrosion, and the like, particularly when removal of the implant is difficult and involves invasive surgery. Stenting may have additional disadvantages for treating diffuse artery disease, for treating bifurcations, for treating areas of the body susceptible to crush, and for treating arteries subject to torsion,  
15 elongation, and shortening.

[0008] A variety of modified restenosis treatments or restenosis-inhibiting treatment modalities have also been proposed, including intravascular radiation, cryogenic treatments, ultrasound energy, and the like, often in combination with balloon angioplasty and/or stenting. While these and different approaches show varying degrees of promise for  
20 decreasing the subsequent degradation in blood flow following angioplasty and stenting, the trauma initially imposed on the tissues by angioplasty remains problematic.

[0009] A number of alternatives to stenting and balloon angioplasty so as to open stenosed arteries have also been proposed. For example, a wide variety of atherectomy devices and techniques have been disclosed and attempted. Despite the disadvantages and limitations of  
25 angioplasty and stenting, atherectomy has not gained the widespread use and success rates of dilation-based approaches. More recently, still further disadvantages of dilation have come to light. These include the existence of vulnerable plaque, which can rupture and release materials that may cause myocardial infarction or heart attack.

[0010] In light of the above, it would be advantageous to provide methods and systems for  
30 inducing vasodilation in artery tissue and remodeling of the lumens of the body. It would further be desirable to avoid significant cost or complexity while providing structures which

could remodel body lumens without having to resort to the trauma of extreme dilation, and to allow the opening of blood vessels and other body lumens which are not suitable for stenting.

#### BRIEF SUMMARY OF THE INVENTION

5 [0011] In a first aspect, embodiments of the present invention provide a method for heating a body tissue region adjacent a body lumen, the region having both a first tissue type and a second tissue type. The method includes positioning an energy delivery portion of a catheter body within the lumen adjacent the body tissue region to be heated, determining a pulse  
10 energy characteristic in response to a thermal property of the first tissue type and applying pulsed energy with the pulse characteristic from the energy delivery portion so as to therapeutically treat the second tissue type within the body tissue region by drawing heat from the first tissue type at a rate that avoids significant thermal damage to the first tissue type while building-up heat in the second tissue type.

[0012] In another aspect, embodiments of the present invention provide a catheter system  
15 for heating a body tissue region adjacent a body lumen, the region having both a first tissue type and a second tissue type. The system includes an elongate flexible catheter body having a proximal end and a distal end with an axis therebetween, an energy delivery portion proximate the distal end, an energy source coupled to the energy delivery portion and a processor coupled to the energy source, the processor configured to control a pulse  
20 characteristic of pulsed energy transmitted from the energy source to the energy delivery portion so as to therapeutically treat the second tissue type within the body tissue region by drawing heat from the first tissue type at a rate that avoids significant thermal damage to the first tissue type while building-up heat in the second tissue type.

[0013] In many embodiments, the pulsed energy preferentially heats the second tissue type  
25 more than the first tissue type, the preferential heating induced at least in part by one or more of the following group of characteristics of the second tissue type: lower thermal conduction than a thermal conduction of the first tissue type, lower specific heat capacity than a specific heat capacity of the first tissue type, less innate blood perfusion than an innate blood perfusion of the first tissue type, and/or larger distance away from well-perfused areas than a  
30 distance between well-perfused areas and the first tissue type.

[0014] In many embodiments, most of the group of characteristics cause heat to be drawn from the first tissue type at a rate that avoids significant thermal damage to the first tissue type, while allowing heat to build up in the second tissue type.

5 [0015] In many embodiments, the pulsed energy is delivered at an average rate of 0.25 to 5 watts to the body tissue region.

[0016] In many embodiments, each pulse of the pulsed energy provides between 4 to 45 Joules to the body tissue region.

10 [0017] In many embodiments, wherein an average rate of pulsed energy delivered to the body tissue region is between about 0.1 and 10.0 times the rate of energy dissipation by the first tissue type.

[0018] In many embodiments, a time period between pulses allows the first tissue type to dissipate its heat adequately to avoid thermal damage to the first tissue type by the pulsed energy.

15 [0019] In many embodiments, the time period between pulses of energy is between 0.1 to 180 seconds.

[0020] In many embodiments, a thermal time constant for the first tissue type is approximately how long it will take a discrete volume of that given tissue to lose 63% of its heat while undergoing an exponential decay.

20 [0021] In many embodiments, the pulsed energy is delivered to the body tissue region over a duration of at least several first tissue type time constants, wherein the thermal time constant of the first tissue is proportional to a thermal conductivity of the first tissue type.

[0022] In many embodiments, the thermal conductivity of the second tissue type is twice that of the first tissue type.

25 [0023] In many embodiments, the energy source comprises a radio frequency (RF) energy source.

30 [0024] In many embodiments, the energy delivery portion comprises a radially expandable structure engaging a plurality of electrode surfaces against the body lumen, wherein the plurality of electrode surfaces against the body lumen complete a plurality of circuits comprising the first tissue type and the second tissue type and pulsed energy is delivered to the plurality of circuits.

[0025] In many embodiments, the energy source comprises a laser energy source.

[0026] In many embodiments, the energy delivery portion comprises at least one radially oriented window coupled to at least one optical conduit extending between the proximal end of the catheter body and the at least one window for transmission of pulsed laser energy to  
5 the body tissue region.

[0027] In many embodiments, the energy source comprises an ultrasound transmitter configured to deliver pulsed ultrasound energy to the body tissue region.

[0028] In many embodiments, the energy source comprises a microwave energy source including at least one microwave antenna configured to deliver pulsed microwave energy to  
10 the body tissue region.

#### BRIEF DESCRIPTION OF THE DRAWINGS

[0029] FIG. 1 schematically illustrates one embodiment of a catheter system for heating artery tissue.

15 [0030] FIG. 2 illustrates one embodiment of a balloon for use in the catheter system of FIG. 1.

[0031] FIG. 3 shows what a temperature vs. time profile for heating both healthy tissue and diseased tissue at a constant pulsed rate of heat or energy.

[0032] FIG. 4 shows another a temperature vs. time profile for tissue having both healthy  
20 tissue and diseased tissue in which the heat or energy is applied at different rates.

[0033] FIG. 5 shows heat dissipation's effect on temperature.

[0034] Fig. 6 schematically illustrates one embodiment of balloon catheter system for use for bipolar treatment of tissue in a leg

[0035] Fig. 7 schematically illustrates one embodiment of balloon catheter system for use  
25 for monopolar treatment of tissue in a leg.

[0036] Figs. 8A-8C illustrate a method of using a balloon catheter system treating artery tissue.

## DETAILED DESCRIPTION OF THE INVENTION

[0037] Many therapies have been developed to replace or improve upon traditional balloon angioplasty and stents. Many of the devices described in the BACKGROUND OF THE INVENTION either cut, ablate, or vaporize diseased tissue in an artery. For example, laser  
5 devices vaporize plaque and flush it downstream. Atherectomy devices excise plaque and suck it out of the body. Cutting balloons incise the artery wall, damaging the tissue.

[0038] It would be advantageous to provide systems and devices that do not cut, ablate, or vaporize. Three modalities of treatment avoid these drawbacks, they include: cooling the tissue; non-ablative forms of direct molecular denaturing; and non-ablative heating. Cooling  
10 has been implemented using devices such as Boston Scientific's Cryo-cath. Direct molecular denaturing can be achieved with radiation -- gamma rays, for instance. The present invention is directed to the remaining modality, non-ablative heating.

[0039] Some embodiments of the present invention generally provide devices, systems, and methods for heating artery tissue with diseased portions using selective accumulation of  
15 energy in the artery tissue with or without knowledge of tissue topography, discussed in more detail below. The invention will be particularly useful for remodeling materials along a partially occluded artery in order to open the artery lumen and increase blood flow. The devices, systems, and methods disclosed herein may be used in any artery, for example, the femoral, popliteal, coronary and/or carotid arteries. Devices for heating artery tissue have  
20 been disclosed in co-pending U.S Patent Application Nos. 11/975,474, 11/975,383, 11/122,263 and U.S. Provisional Application No. 61/099,155, the full disclosures of which are incorporated herein by reference.

[0040] While the disclosure focuses on the use of the technology in the vasculature, the technology would also be useful for any luminal obstruction. Other anatomical structures in  
25 which the present invention may be used are the esophagus, the oral cavity, the nasopharyngeal cavity, the auditory tube and tympanic cavity, the sinus of the brain, the arterial system, the venous system, the heart, the larynx, the trachea, the bronchus, the stomach, the duodenum, the ileum, the colon, the rectum, the bladder, the ureter, the ejaculatory duct, the vas deferens, the urethra, the uterine cavity, the vaginal canal, and the  
30 cervical canal.

[0041] Some embodiments of the system will be able to treat tissue by gentle heating in combination with dilation of the artery. The heating of the vessel wall may be done before,

during, and/or after dilation with the balloon, with dilation pressures which are at or significantly lower than standard, unheated angioplasty dilation pressures. For example, where balloon inflation pressures of 10-16 atmospheres may be appropriate for standard angioplasty dilation of a particular lesion, modified dilation treatments combined with gentle heating described herein may employ from 10-16 atmospheres or may be effected with pressures of 6 atmospheres or less, and possibly as low as 1 to 2 atmospheres. In case of calcification in the artery plaque, it may be more difficult to remodel and open the diseased artery, so the catheter may use a standard angioplasty balloon in combination with ultrasonic energy to break down the calcium and remodel and open the lumen.

5 [0042] The gentle heating energy added before, during, and/or after dilation of a blood vessel may increase dilation effectiveness while lowering complications. In some embodiments, such controlled heating with balloon dilatation may exhibit a reduction in recoil, providing at least some of the benefits of a stent-like expansion without the disadvantages of an implant. Benefits of gentle heating may be enhanced (and/or complications inhibited) by limiting heating of the adventitial layer below a deleterious response threshold. In many cases, such heating of the intima and/or media may be provided using heating times of less than about 10 seconds, often being less than 3 (or even 2) seconds. In other cases, very low power may be used for longer durations.

15 [0043] Heating of the body tissue involves the application of energy, typically in the form of RF, microwave and/or ultrasound energy, and the like. This energy will be controlled so as to limit a temperature of the body tissue. In some embodiments, the body tissue temperature range is from about 50°C to about 90°C, depending on the energy applied and tissue type.

20 [0044] While the methods and devices described herein are not selective in tissue treatment of the blood vessel, the devices can be used for treatment of both concentric and eccentric atherosclerosis. This non selective treatment is a particular advantage because atherosclerosis may be eccentric relative to an axis of the blood vessel over 50% of the time, possibly in as much as (or even more than) 75% of cases.

25 [0045] While the present invention may be used in combination with stenting, the present invention is particularly well suited for increasing the open diameter of blood vessels in which stenting is not a viable option. Potential applications include treatment of diffuse disease, in which atherosclerosis is spread along a significant length of an artery rather than



being localized in one area. The present invention may also find advantageous use for treatment of tortuous, sharply-curved vessels, as no stent need be advanced into or expanded within the sharp bends of many blood vessel. Still further advantageous applications include treatment along bifurcations (where side branch blockage may be an issue) and in the  
5 peripheral extremities such as the legs, feet, and arms (where crushing and/or stent fracture failure may be problematic).

[0046] The disclosed system includes at least an energy source and a catheter with an energy delivery portion configured for heating a body tissue region adjacent a body lumen, the region having both a first tissue type, such as healthy tissue, and a second tissue type,  
10 such as diseased tissue. The catheter may be similar to a balloon catheter commonly used to treat artery disease today, except for the addition of electrodes used for heating. Other embodiments may use transducers disposed on the balloon to apply ultrasound heating to the vessel wall or microwave antennas disposed on the balloon to apply microwave heating to the vessel wall. The energy source may be coupled to a processor to control a pulse  
15 characteristic of pulsed energy transmitted from the energy source to the energy delivery portion so as to therapeutically treat the tissue within the body treatment region without causing sufficient thermal damage to the body treatment region so as to induce a long-term occlusive response.

[0047] In use, the energy delivery portion of a catheter body is positioned within the lumen adjacent the body tissue region to be heated. A pulse characteristic is determined in response  
20 to a thermal property of the first tissue type, and the pulsed energy is applied with the pulse characteristic from the energy delivery portion so as to therapeutically treat the body tissue region.

[0048] Fig. 1 shows one embodiment of a catheter system 10 for heating artery tissue. The  
25 catheter system 10 includes a balloon catheter 12 having a catheter body 14 with a proximal end 16 and a distal end 18. Catheter body 14 is flexible and defines a catheter axis 15, and may include one or more lumens, such as a guidewire lumen 22 and an inflation lumen 24 (see Fig. 2). Still further lumens may be provided if desired for other treatments or applications, such as perfusion, fluid delivery, imaging, or the like. Catheter 12 includes an  
30 inflatable balloon 20 adjacent distal end 18 and a housing 29 adjacent proximal end 16. Housing 29 includes a first connector 26 in communication with guidewire lumen 22 and a second connector 28 in fluid communication with inflation lumen 24. Inflation lumen 24

extends between balloon 20 and second connector 28. Both first and second connectors 26, 28 may optionally comprise a standard connector, such as a Luer-Loc™ connector. A distal tip may include an integral tip valve to allow passage of guidewires, and the like.

[0049] Housing 29 also accommodates an electrical connector 38. Connector 38 includes a plurality of electrical connections, each electrically coupled to electrodes 34 via conductors 36. This allows the electrodes 34 to be easily energized, the electrodes often being energized by a controller 40 and energy source 42, such as bipolar or monopolar RF energy, microwave energy, ultrasound energy, or other suitable energy sources. In one embodiment, electrical connector 38 is coupled to an RF generator via a controller 40, with controller 40 allowing energy to be selectively directed to electrodes 38. When monopolar RF energy is employed, patient ground may (for example) be provided by an external electrode or an electrode on catheter body 14. .

[0050] In some embodiments, controller 40 may include a processor or be coupled to a processor to control or record treatment. The processor will typically comprise computer hardware and/or software, often including one or more programmable processor unit running machine readable program instructions or code for implementing some or all of one or more of the methods described herein. The code will often be embodied in a tangible media such as a memory (optionally a read only memory, a random access memory, a non-volatile memory, or the like) and/or a recording media (such as a floppy disk, a hard drive, a CD, a DVD, a non-volatile solid-state memory card, or the like). The code and/or associated data and signals may also be transmitted to or from the processor via a network connection (such as a wireless network, an Ethernet, an internet, an intranet, or the like), and some or all of the code may also be transmitted between components of catheter system 10 and within processor via one or more bus, and appropriate standard or proprietary communications cards, connectors, cables, and the like will often be included in the processor. Processor will often be configured to perform the calculations and signal transmission steps described herein at least in part by programming the processor with the software code, which may be written as a single program, a series of separate subroutines or related programs, or the like. The processor may comprise standard or proprietary digital and/or analog signal processing hardware, software, and/or firmware, and will typically have sufficient processing power to perform the calculations described herein during treatment of the patient, the processor optionally comprising a personal computer, a notebook computer, a tablet computer, a proprietary processing unit, or a combination thereof. Standard or proprietary input devices

(such as a mouse, keyboard, touchscreen, joystick, etc.) and output devices (such as a printer, speakers, display, etc.) associated with modern computer systems may also be included, and processors having a plurality of processing units (or even separate computers) may be employed in a wide range of centralized or distributed data processing architectures.

5 [0051] Balloon 20 is illustrated in more detail in Fig. 2. Balloon 20 generally includes a proximal portion 30 coupled to inflation lumen 24 and a distal portion 32 coupled to guidewire lumen 22. Balloon 20 expands radially when inflated with a fluid or a gas. In some embodiments, the fluid or gas may be non-conductive and/ cooled. In some  
10 embodiments, balloon 20 may be a low pressure balloon pressurized to contact the artery tissue. In other embodiments, balloon 20 is an angioplasty balloon capable of higher pressure to both heat the artery tissue and expand the artery lumen. Balloon 20 may comprise a compliant or non-compliant balloon having helical folds to facilitate reconfiguring the balloon from a radially expanded, inflated configuration to a low profile configuration, particularly for removal after use.

15 [0052] Electrodes 34 are mounted on a surface of balloon 20, with associated conductors 36 extending proximally from the electrodes. Electrodes 34 may be arranged in many different patterns or arrays on balloon 20. The system may be used for monopolar or bipolar application of energy. For delivery of monopolar energy, a ground electrode is used, either  
20 on the catheter shaft, or on the patients skin, such as a ground electrode pad. For delivery of bipolar energy, adjacent electrodes are axially offset to allow bipolar energy to be directed between adjacent circumferential (axially offset) electrodes. In other embodiments, electrodes may be arranged in bands around the balloon to allow bipolar energy to be directed between adjacent distal and proximal electrodes. In some embodiments, the electrodes 34 may be positioned internal of balloon 20. Electrodes 34 may be arranged in many different  
25 patterns or arrays on balloon 20. As mentioned previously, other embodiments may include ultrasound transducers or microwave antennas mounted on a surface of balloon 20.

[0053] The embodiments disclosed herein revolve around the concept of selective accumulation of energy in artery tissue with or without knowledge of tissue topography. This is accomplished by taking advantage of the differences in tissue properties between healthy  
30 tissue and diseased tissue. The preferential heating of the tissues with different properties can be accomplished without knowing the location or type the different tissues. If a first tissue type has a better thermal conductivity ( $k$ ) than a second tissue type, it will conduct heat away

more rapidly. If the second tissue type has a lower specific heat capacity ( $c_p$ ) than the first tissue type, its temperature will increase more given the same amount of energy applied to the same mass (and volume, assuming relatively similar tissue density). If the first tissue type has denser vasculature, or is reliably in closer proximity to well-perfused areas, it will  
5 conduct heat away more rapidly than the second tissue type.

[0054] This present invention allows preferentially heating of a type of tissue that has one or more of the following characteristics:

- Relatively poor (lower) thermal conduction,
- Lower specific heat capacity,
- 10 • Less innate blood perfusion, and/or
- Relatively larger distance away from well-perfused areas.

[0055] In the case of diseased tissue, all of the above characteristics apply. The disease is generally comprised of lipidic fat-like diseased tissue and/or fibrous collagen-like tissue. Both of these tissues have a lower specific heat capacity and lower thermal conductivity than  
15 healthy vascular tissue, particularly media. Healthy vascular tissue also has more microvasculature, and is in closer proximity to well-perfused tissue, therefore healthy tissue can sink heat away more effectively, without the heat flux “backing up” like a traffic jam.

[0056] The key to taking advantage of this discrepancy in tissue properties is the following: Heat is applied or generated within the tissue at a rate commensurate with the thermal time  
20 constants of the tissues involved, possibly using a pulse width modulation (PWM) approach. During each “pulse”, the same quantity of energy is delivered or generated regardless of the tissue type. Tissue topography may be unknown, therefore the same “treatment” is applied everywhere. However, in the diseased tissue, the temperature profile will be higher everywhere because it has a lower heat capacity. The diseased tissue will also retain its heat  
25 longer because it has lower thermal conductivity and therefore a longer thermal time constant. Thus, the healthy tissue will heat up slower and cool off faster, which is exactly what is desired for this particular application. The goal is to heat diseased tissue while not heating healthy tissue. The amount of time between pulses can then be tailored to allow the healthy tissue to cool and dissipate its heat adequately so as not to exceed a particular amount  
30 of thermal damage the healthy tissue.

[0057] FIG. 3 shows what a temperature vs. time profile for heating both healthy tissue 110 and diseased tissue 120 at a constant pulsed rate of heat or energy. The diseased tissue

temperature will rise faster and cool slower than the healthy tissue, therefore accumulating heat and receiving treatment significantly more than healthy tissue.

[0058] FIG. 4 shows another a temperature vs. time profile for tissue having both healthy tissue and diseased tissue in which the heat or energy is applied at different rates. The figure shows it is possible to initially apply or generate heat faster (at the beginning of the treatment) in order to ramp up the tissue temperature more quickly. This could be done with power modulation or PWM with a variable pulse width. The purpose of this would be to heat the tissue quickly and then allow the healthy tissue to dissipate heat between pulses, which would decrease the total treatment time required to achieve (and possibly soak at) a certain temperature.

[0059] TIME CONSTANT:

$$t = RC = \left(\frac{l}{n}k\right)(mc_p), \text{ where healthy } t \approx 7\text{s and diseased } t \approx 14\text{s.}$$

[0060] HEAT CAPACITY:

Media  $c_p \approx 3.9$

15 Adventitia  $c_p \approx 3.1$

Fat  $c_p \approx 2.4$

[0061] THERMAL CONDUCTIVITY:

Media  $k \approx .59$

Adventitia  $k \approx .49$

20 Fat  $k \approx .20$

[0062] The "TIME CONSTANT" above is the thermal time constant. This is approximately how long it will take a discrete volume of that given tissue to lose 63% of its heat (and therefore temperature) while undergoing an exponential decay. The thermal time constant is directly proportional to the thermal conductivity. Therefore, because there is approximately a 2:1 ratio between the thermal conductivity of fatty diseased tissue and healthy media tissue, there is also a 2:1 ratio between their time constants.

[0063] The thermal time constant for healthy media tissue was estimated to be 7 seconds based upon a treatment volume of  $32 \text{ mm}^3$ , a thermal conductivity of  $0.5 \text{ W/m/K}$ , a thermal

front cross-sectional area of 32 mm<sup>2</sup>, and a specific heat capacity of 3.6 J/g/K. In this case, one would want to deliver an appropriate therapeutic dose of energy over a duration of at least several time constants, e.g. 35 seconds, 70 seconds, etc.

[0064] FIG. 5 shows heat dissipation's effect on temperature versus time. Because thermal  
5 dissipation will happen according to an exponential decay, the rate of cooling will vary nonlinearly with time. So, the period has to be selected appropriately in conjunction with the power and duty cycle. The power and the heat capacity, neglecting heat dissipation, will determine the rate of temperature increase during heating. The combination of power, duty  
10 cycle, heat capacity, and the rate of continuous heat dissipation, will determine the average rate of temperature change. Diseased tissue 210 and healthy tissue 220 both have higher average temperatures without heat dissipation than diseased tissue 215 and healthy tissue 225 with heat dissipation.

[0065] The important thing to note about FIG. 5 is that the average power (average energy  
per time) has to be low enough that the rate of heat dissipation is significant in comparison.  
15 In other words, if we were to assume that healthy vessel tissue in a certain geometry can effectively dissipate energy at a rate of 2 Joules per second (2 Watts), then the average rate of energy application needs to be on this order of magnitude as well, in order for the effect to be significant.

[0066] This is the main crux of the invention – applying energy at an average rate  
20 commensurate with the thermal time constants involved such that significant differences in the tissues' thermal properties can be leveraged to our advantage.

[0067] Fig. 6 schematically illustrates bipolar treatment of tissue with the system 10.  
Balloon 20 having electrode pairs 34A and 34B is positioned within an artery lumen having  
fatty disease/necrotic core 48, fibrous disease/fibrous cap 44, healthy tissue 45. Treatment is  
25 done to healthy tissue 45 and the fatty disease/necrotic core 48, fibrous disease/fibrous cap 44 by pulsed energy between electrode pairs 34A and 34B. The electrode pairs may be any electrode pairs on the balloon, for example, in some embodiments, the electrode pairs may be 34A and 34C, or 34A and 34D, or any combination of 34A-34D. This arrangement creates  
30 an energy path 50 through the tissue that delivers energy or heat ("tissue remodeling energy") to the artery tissue between the electrode pairs ("remodeling zones"). Using different combinations of electrode pairs may reduce or eliminate gaps between the remodeling zones by using overlapping pairs. Using electrode pairs with bipolar energy may avoid some

potential issues of the monopolar approach. Diseased artery tissue 48 has a higher electrical resistivity than healthy artery tissue 45. By using pairs of electrodes 34A, 34B in a bipolar system, the energy path 50 will go through the healthy tissue, diseased tissue, or a combination of both healthy and diseased tissues between the electrode pairs. Any number of  
5 electrode pairs may be used in different patterns or arrays.

**[0068]** Fig. 7 schematically illustrates bipolar treatment of tissue with the system 10. Balloon 20 having electrode pairs 34A and 34B is positioned within an artery lumen having fatty disease/necrotic core 48, fibrous disease/fibrous cap 44, healthy tissue 45 and one or more electrical grounds (not shown) are used, such as positioned on the patients skin. When  
10 power is applied to the multiple monopolar electrodes 34 arranged around the circumference of the artery lumen, energy 54 is directed radially outward through the artery wall and treats both diseased and healthy artery tissue.

**[0069]** The use of catheter system 10 for treating tissue by pulsed energy can be understood with reference to Figs. 8A-8C. As seen in Fig. 8A, accessing of a treatment site  
15 will often involve advancing a guidewire 56 within a blood vessel 58 at a target region of diseased tissue 48. Location of balloon 20 may be facilitated by radiopaque markers or by radiopaque structure (or corresponding radiopaque markers placed on or near) balloon 20, and/or by the use of radiopaque electrodes 34. Guidewire 56 may be positioned under fluoroscopic (or other) imaging.

**[0070]** Catheter 12 is advanced distally over guidewire 56 and positioned adjacent to atherosclerotic material 48. Balloon 20 expands radially within the lumen of the blood vessel so that electrodes 34, or electrodes 34A and 34B, radially engage artery tissue. As diseased  
20 tissue 48 may be distributed eccentrically about catheter 12, electrodes 34 may engage diseased tissue 48, healthy tissue 60, or a combination of both tissues.

**[0071]** As discussed above, electrodes 34 are positioned circumferentially around the balloon 20. Pulsed energy is directed to electrodes 34, or adjacent pairs of electrodes 34A and 34B, treating both diseased tissue 48 and the healthy tissue 60. The controller 40 may provide pulsed energy to energize the electrodes with about 0.25 to 5 Watts average power  
25 for 0.1 to 180 seconds, or with about 4 to 45 Joules. The power and duration are calibrated to  
30 be less than enough to cause severe damage, and particularly less than enough to ablate tissue within a blood vessel.

[0072] Referring now to Fig. 8C, as described above, balloon 20 may be an angioplasty balloon that combines heating with opening the artery lumen, such that the heat is preferentially delivered to the diseased tissue 48, for example to mildly heat a cap structure (to induce thickening of the cap and make the plaque less vulnerable to rupture) and/or heat a lipid-rich pool of the vulnerable plaque (so as to remodel, denature, melt, shrink, and/or redistribute the lipid-rich pool), while the healthy tissue 60 dissipates the heat without damage.

[0073] In some embodiments, balloon 20 may be repeatedly contracted, axial movement of the catheter 12 employed to reposition balloon 20, with subsequent expansion of balloon 20 at each of a plurality of treatment locations along diseased tissue.

[0074] While generally described herein with reference to the vasculature, embodiments of the catheter devices, systems, and methods described herein may also find applications in the lumens of other vessels of the human anatomy having tissue types with different tissue properties, as discussed above. The anatomical structure into which the catheter is placed may be for example, the esophagus, the oral cavity, the nasopharyngeal cavity, the auditory tube and tympanic cavity, the sinus of the brain, the larynx, the trachea, the bronchus, the stomach, the duodenum, the ileum, the colon, the rectum, the bladder, the ureter, the ejaculatory duct, the vas deferens, the urethra, the uterine cavity, the vaginal canal, and the cervical canal, as well as the arterial system, the venous system, and/or the heart.

[0075] While the exemplary embodiments have been described in some detail, by way of example and for clarity of understanding, those of skill in the art will recognize that a variety of modifications, adaptations, and changes may be employed. Hence, the scope of the present invention should be limited solely by the claims.



WHAT IS CLAIMED IS:

1                   1.       A method for heating a body tissue region adjacent a body lumen, the  
2 region having both a first tissue type and a second tissue type, the method comprising:  
3                   positioning an energy delivery portion of a catheter within the lumen adjacent  
4 the body tissue region to be heated;  
5                   determining a pulse characteristic in response to a thermal property of the first  
6 tissue type; and  
7                   applying pulsed energy with the pulse characteristic from the energy delivery  
8 portion so as to therapeutically treat the second tissue type within the body tissue region by  
9 drawing heat from the first tissue type at a rate that avoids significant thermal damage to the  
10 first tissue type while building-up heat in the second tissue type.

1                   2.       The method of claim 1, wherein the pulsed energy preferentially heats  
2 the second tissue type more than the first tissue type, the preferential heating induced at least  
3 in part by one or more of the following group of characteristics of the second tissue type:  
4 lower thermal conduction than a thermal conduction of the first tissue type, lower specific  
5 heat capacity than a specific heat capacity of the first tissue type, less innate blood perfusion  
6 than an innate blood perfusion of the first tissue type, and/or larger distance away from well-  
7 perfused areas than a distance between well-perfused areas and the first tissue type.

1                   3.       The method of claim 2, wherein most of the group of characteristics  
2 cause heat to be drawn from the first tissue type at a rate that avoids significant thermal  
3 damage to the first tissue type, while allowing heat to build up in the second tissue type.

1                   4.       The method of claim 1, wherein the pulsed energy is delivered at an  
2 average rate of 0.25 to 5 watts to the body tissue region.

1                   5.       The method of claim 1, wherein each pulse of the pulsed energy  
2 provides between 4 to 45 Joules to the body tissue region.

1                   6.       The method of claim 1, wherein an average rate of pulsed energy  
2 delivered to the body tissue region is between about 0.1 and 10.0 times the rate of energy  
3 dissipation by the first tissue type.

1                   7.       The method of claim 1, wherein a time period between pulses allows  
2 the first tissue type to dissipate its heat adequately to avoid thermal damage to the first tissue  
3 type by the pulsed energy.

1                   8.       The method of claim 1, wherein the time period between pulses of  
2 energy is between 0.1 to 180 seconds.

1                   9.       The method of claim 1, wherein a thermal time constant for the first  
2 tissue type is approximately how long it will take a discrete volume of that given tissue to  
3 lose 63% of its heat while undergoing an exponential decay.

1                   10.      The method of claim 1, wherein the pulsed energy is delivered to the  
2 body tissue region over a duration of at least several first tissue type time constants, wherein  
3 the thermal time constant of the first tissue is proportional to a thermal conductivity of the  
4 first tissue type.

1                   11.      The method of claim 10, wherein the thermal time constants are  
2 proportional to a thermal conductivity of the first tissue type.

1                   12.      The method of claim 11, wherein the thermal conductivity of the  
2 second tissue type is twice that of the first tissue type.

1                   13.      The method of claim 1, wherein the energy source comprises a radio  
2 frequency (RF) energy source.

1                   14.      The method of claim 13, wherein the energy delivery portion  
2 comprises a radially expandable structure engaging a plurality of electrode surfaces against  
3 the body lumen, wherein the plurality of electrode surfaces against the body lumen complete  
4 a plurality of circuits comprising the first tissue type and the second tissue type and pulsed  
5 energy is delivered to the plurality of circuits.

1                   15.      The method of claim 1, wherein the energy source comprises a laser  
2 energy source.

1                   16.      The method of claim 15, wherein the energy delivery portion  
2 comprises at least one radially oriented window coupled to at least one optical conduit

3 extending between the proximal end of the catheter body and the at least one window for  
4 transmission of pulsed laser energy to the body tissue region.

1           17.    The method of claim 1, wherein the energy source comprises an  
2 ultrasound transmitter configured to deliver pulsed ultrasound energy to the body tissue  
3 region.

1           18.    The method of claim 1, wherein the energy source comprises a  
2 microwave energy source including at least one microwave antenna configured to deliver  
3 pulsed microwave energy to the body tissue region.

1           19.    A catheter system for heating a body tissue region adjacent a body  
2 lumen, the region having both a first tissue type and a second tissue type, the system  
3 comprising:  
4            an elongate flexible catheter body having a proximal end and a distal end with  
5 an axis therebetween;  
6            an energy delivery portion proximate the distal end;  
7            an energy source coupled to the energy delivery portion; and  
8            a processor coupled to the energy source, the processor configured to control a  
9 pulse characteristic of pulsed energy transmitted from the energy source to the energy  
10 delivery portion so as to therapeutically treat the second tissue type within the body tissue  
11 region by drawing heat from the first tissue type at a rate that avoids significant thermal  
12 damage to the first tissue type while building-up heat in the second tissue type.

1           20.    The system of claim 19, wherein the pulsed energy preferentially heats  
2 the second tissue type more than the first tissue type, the preferential heating induced at least  
3 in part by one or more of the following group of characteristics of the second tissue type:  
4 lower thermal conduction than a thermal conduction of the first tissue type, lower specific  
5 heat capacity than a specific heat capacity of the first tissue type, less innate blood perfusion  
6 than an innate blood perfusion of the first tissue type, and/or larger distance away from well-  
7 perfused areas than a distance between well-perfused areas and the first tissue type.

1           21.    The system of claim 20, wherein most of the group of characteristics  
2 cause heat to be drawn from the first tissue type at a rate that avoids significant thermal  
3 damage to the first tissue type, while allowing heat to build up in the second tissue type.

1                   22.     The system of claim 19, wherein the pulsed energy is delivered at an  
2 average rate of 0.25 to 5 watts to the body tissue region.

1                   23.     The system of claim 19, wherein each pulse of the pulsed energy  
2 provides between 04 to 45 Joules to the body tissue region.

1                   24.     The system of claim 19, wherein an average rate of pulsed energy  
2 delivered to the body tissue region is between about 0.1 and 10.0 times the rate of energy  
3 dissipation by the first tissue type.

1                   25.     The system of claim 19, The method of claim 1, wherein a time period  
2 between pulses allows the first tissue type to dissipate its heat adequately to avoid thermal  
3 damage to the first tissue type by the pulsed energy.

1                   26.     The system of claim 19, wherein the time period between pulses of  
2 pulsed energy is between 0.1 to 180 seconds.

1                   27.     The system of claim 19, wherein a thermal time constant for the first  
2 tissue type is approximately how long it will take a discrete volume of that given tissue to  
3 lose 63% of its heat while undergoing an exponential decay.

1                   28.     The system of claim 19, wherein the pulsed energy is delivered to the  
2 body tissue region over a duration of at least several first tissue type time constants, wherein  
3 the thermal time constant of the first tissue is proportional to a thermal conductivity of the  
4 first tissue type.

1                   29.     The system of claim 28, wherein the thermal conductivity of the  
2 second tissue type is twice that of the first tissue type.

1                   30.     The system of claim 25, wherein the energy source comprises a radio  
2 frequency (RF) energy source.

1                   31.     The method of claim 30, wherein the energy delivery portion  
2 comprises a radially expandable structure engaging a plurality of electrode surfaces against  
3 the body lumen, wherein the plurality of electrode surfaces against the body lumen complete  
4 a plurality of circuits comprising the first tissue type and the second tissue type and pulsed  
5 energy is delivered to the plurality of circuits.

1                   32.    The system of claim 19, wherein the energy source comprises a laser  
2 energy source.

1                   33.    The system of claim 32, wherein the energy delivery portion comprises  
2 at least one radially oriented window coupled to at least one optical conduit extending  
3 between the proximal end of the catheter body and the at least one window for transmission  
4 of pulsed laser energy to the body tissue region.

1                   34.    The method of claim 19, wherein the energy source comprises an  
2 ultrasound transmitter configured to deliver pulsed ultrasound energy to the body tissue  
3 region.

1                   35.    The method of claim 19, wherein the energy source comprises a  
2 microwave energy source including at least one microwave antenna configured to deliver  
3 pulsed microwave energy to the body tissue region.

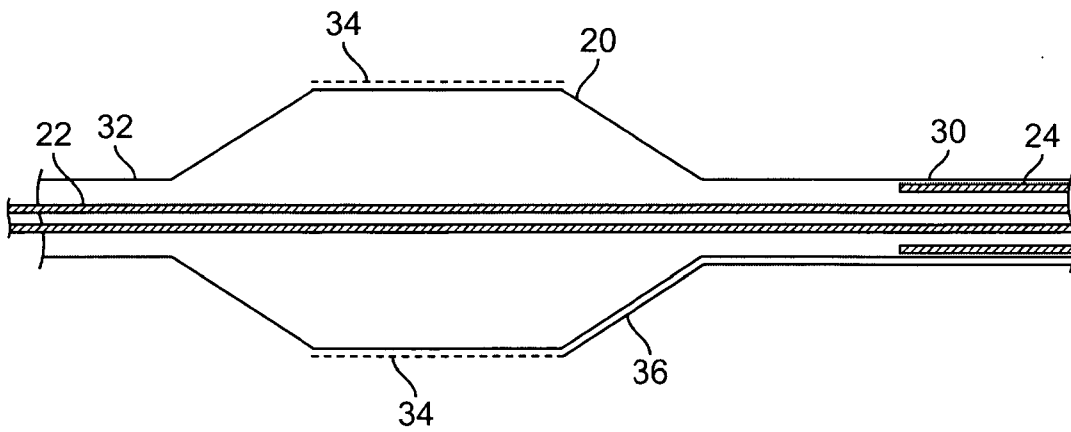
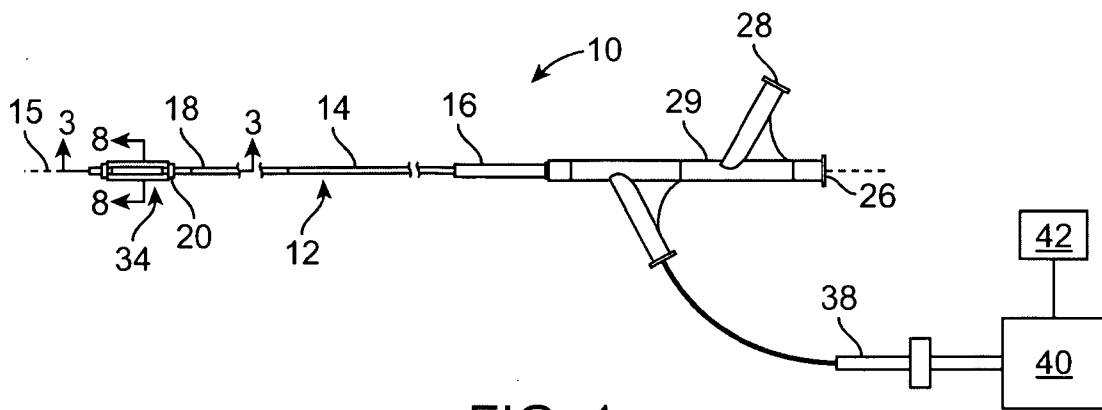

2 / 4

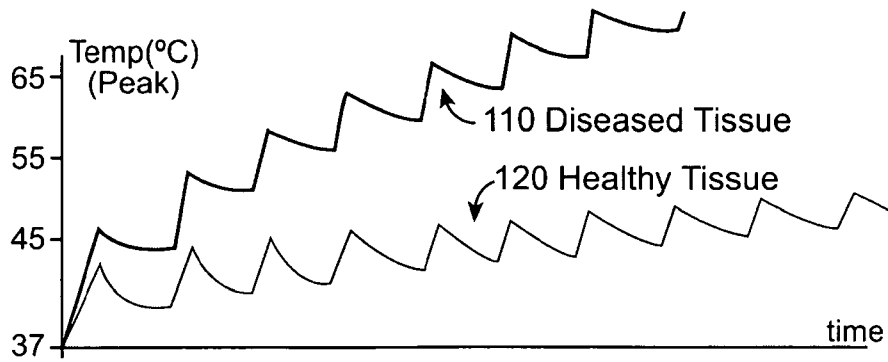

FIG. 3

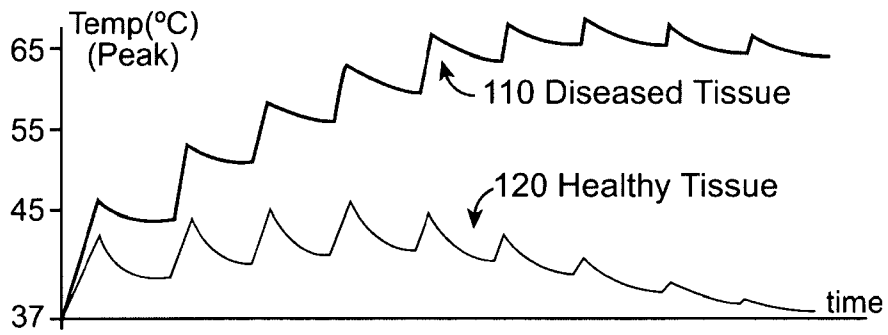

FIG. 4

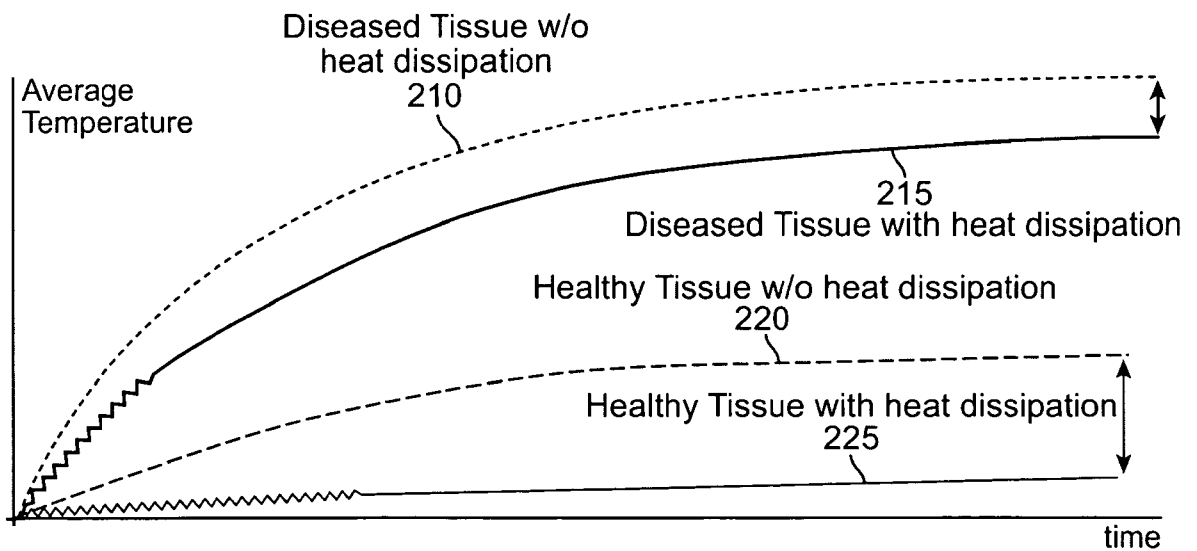

FIG. 5  
SUBSTITUTE SHEET (RULE 26)

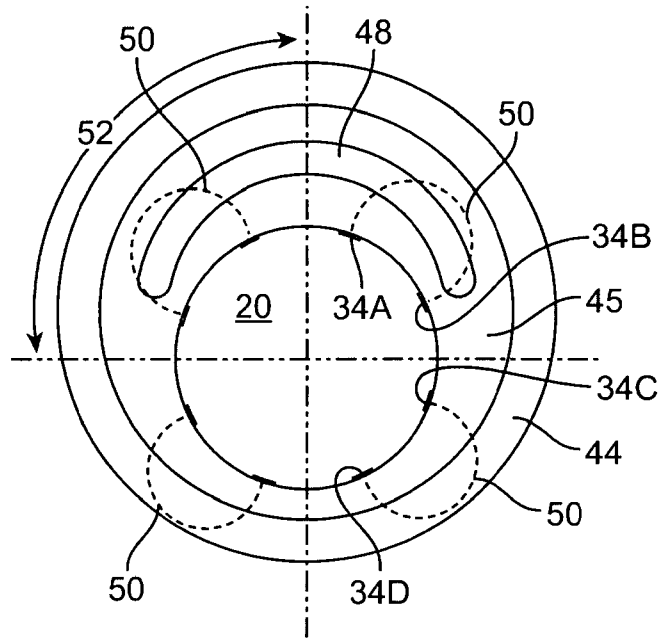

FIG. 6

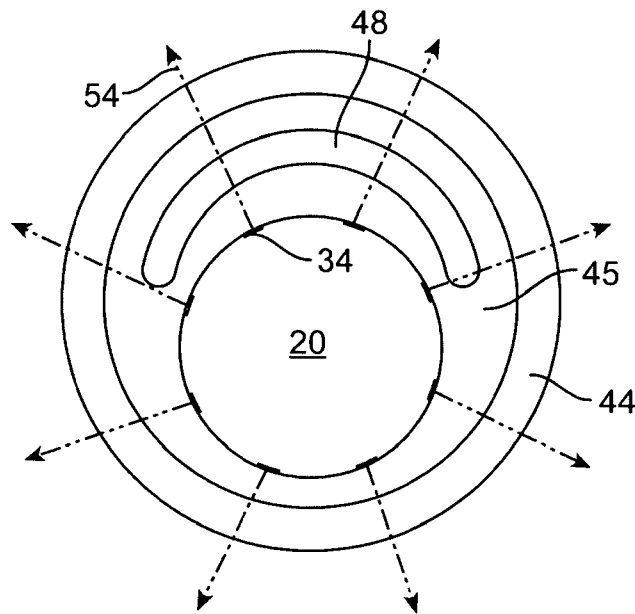

FIG. 7



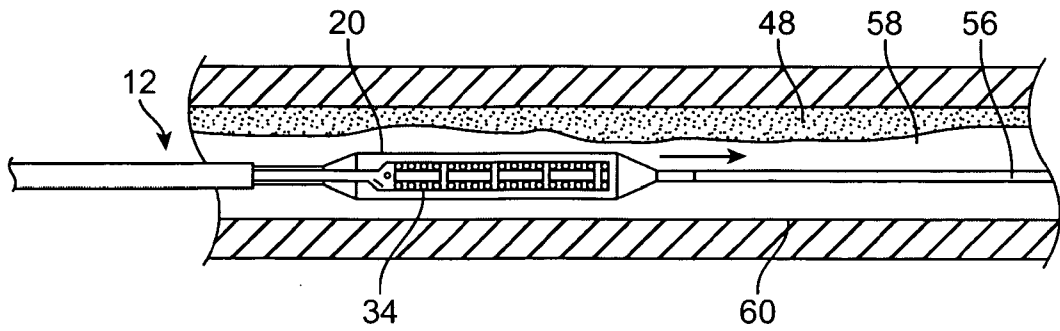

FIG. 8A

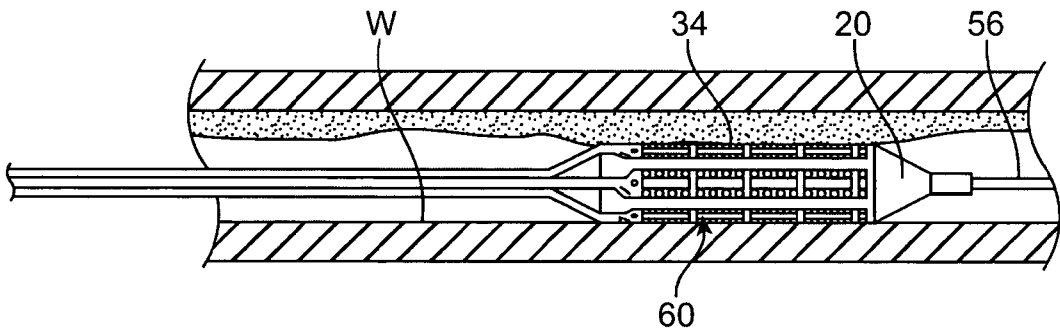

FIG. 8B

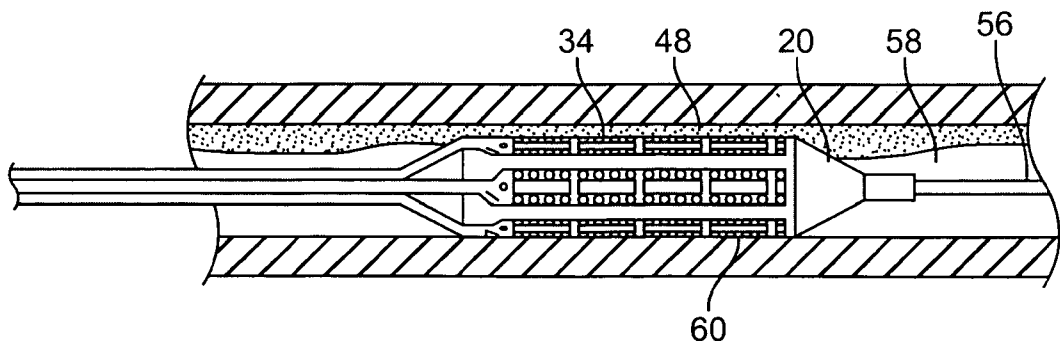

FIG. 8C

INTERNATIONAL SEARCH REPORT

International application No.  
PCT/US2009/064027

<p>A. CLASSIFICATION OF SUBJECT MATTER IPC(8) - A61B 18/14 (2009.01) USPC - 607/99 According to International Patent Classification (IPC) or to both national classification and IPC</p>																				
<p>B. FIELDS SEARCHED</p> <p>Minimum documentation searched (classification system followed by classification symbols) IPC(8) - A61B 18/00, 1/04, 18/10, 18/12, 18/14 (2009.01) USPC - 606/7, 32, 41; 607/96, 98, 99</p> <p>Documentation searched other than minimum documentation to the extent that such documents are included in the fields searched</p> <p>Electronic data base consulted during the international search (name of data base and, where practicable, search terms used) PatBase</p>																				
<p>C. DOCUMENTS CONSIDERED TO BE RELEVANT</p> <table border="1"> <thead> <tr> <th>Category*</th> <th>Citation of document, with indication, where appropriate, of the relevant passages</th> <th>Relevant to claim No.</th> </tr> </thead> <tbody> <tr> <td>Y</td> <td>US 2008/0125772 A1 (STONE et al) 29 May 2008 (29.05.2008) entire document</td> <td>1-35</td> </tr> <tr> <td>Y</td> <td>US 4,784,132 A (FOX et al) 15 November 1988 (15.11.1988) entire document</td> <td>1-35</td> </tr> <tr> <td>Y</td> <td>US 2008/0188912 A1 (STONE et al) 07 August 2008 (07.08.2008) entire document</td> <td>5, 23</td> </tr> <tr> <td>Y</td> <td>US 2008/0188913 A1 (STONE et al) 07 August 2008 (07.08.2008) entire document</td> <td>9-12, 27-29</td> </tr> <tr> <td>Y</td> <td>US 2005/0251116 A1 (STEINKE et al) 10 November 2005 (10.11.2005) entire document</td> <td>15, 16, 32, 33</td> </tr> </tbody> </table>			Category*	Citation of document, with indication, where appropriate, of the relevant passages	Relevant to claim No.	Y	US 2008/0125772 A1 (STONE et al) 29 May 2008 (29.05.2008) entire document	1-35	Y	US 4,784,132 A (FOX et al) 15 November 1988 (15.11.1988) entire document	1-35	Y	US 2008/0188912 A1 (STONE et al) 07 August 2008 (07.08.2008) entire document	5, 23	Y	US 2008/0188913 A1 (STONE et al) 07 August 2008 (07.08.2008) entire document	9-12, 27-29	Y	US 2005/0251116 A1 (STEINKE et al) 10 November 2005 (10.11.2005) entire document	15, 16, 32, 33
Category*	Citation of document, with indication, where appropriate, of the relevant passages	Relevant to claim No.																		
Y	US 2008/0125772 A1 (STONE et al) 29 May 2008 (29.05.2008) entire document	1-35																		
Y	US 4,784,132 A (FOX et al) 15 November 1988 (15.11.1988) entire document	1-35																		
Y	US 2008/0188912 A1 (STONE et al) 07 August 2008 (07.08.2008) entire document	5, 23																		
Y	US 2008/0188913 A1 (STONE et al) 07 August 2008 (07.08.2008) entire document	9-12, 27-29																		
Y	US 2005/0251116 A1 (STEINKE et al) 10 November 2005 (10.11.2005) entire document	15, 16, 32, 33																		
<p><input type="checkbox"/> Further documents are listed in the continuation of Box C. <input type="checkbox"/></p>																				
<p>* Special categories of cited documents:</p> <table border="0"> <tr> <td>"A" document defining the general state of the art which is not considered to be of particular relevance</td> <td>"T" later document published after the international filing date or priority date and not in conflict with the application but cited to understand the principle or theory underlying the invention</td> </tr> <tr> <td>"E" earlier application or patent but published on or after the international filing date</td> <td>"X" document of particular relevance; the claimed invention cannot be considered novel or cannot be considered to involve an inventive step when the document is taken alone</td> </tr> <tr> <td>"L" document which may throw doubts on priority claim(s) or which is cited to establish the publication date of another citation or other special reason (as specified)</td> <td>"Y" document of particular relevance; the claimed invention cannot be considered to involve an inventive step when the document is combined with one or more other such documents, such combination being obvious to a person skilled in the art</td> </tr> <tr> <td>"O" document referring to an oral disclosure, use, exhibition or other means</td> <td>"&amp;" document member of the same patent family</td> </tr> <tr> <td>"P" document published prior to the international filing date but later than the priority date claimed</td> <td></td> </tr> </table>			"A" document defining the general state of the art which is not considered to be of particular relevance	"T" later document published after the international filing date or priority date and not in conflict with the application but cited to understand the principle or theory underlying the invention	"E" earlier application or patent but published on or after the international filing date	"X" document of particular relevance; the claimed invention cannot be considered novel or cannot be considered to involve an inventive step when the document is taken alone	"L" document which may throw doubts on priority claim(s) or which is cited to establish the publication date of another citation or other special reason (as specified)	"Y" document of particular relevance; the claimed invention cannot be considered to involve an inventive step when the document is combined with one or more other such documents, such combination being obvious to a person skilled in the art	"O" document referring to an oral disclosure, use, exhibition or other means	"&" document member of the same patent family	"P" document published prior to the international filing date but later than the priority date claimed									
"A" document defining the general state of the art which is not considered to be of particular relevance	"T" later document published after the international filing date or priority date and not in conflict with the application but cited to understand the principle or theory underlying the invention																			
"E" earlier application or patent but published on or after the international filing date	"X" document of particular relevance; the claimed invention cannot be considered novel or cannot be considered to involve an inventive step when the document is taken alone																			
"L" document which may throw doubts on priority claim(s) or which is cited to establish the publication date of another citation or other special reason (as specified)	"Y" document of particular relevance; the claimed invention cannot be considered to involve an inventive step when the document is combined with one or more other such documents, such combination being obvious to a person skilled in the art																			
"O" document referring to an oral disclosure, use, exhibition or other means	"&" document member of the same patent family																			
"P" document published prior to the international filing date but later than the priority date claimed																				
<p>Date of the actual completion of the international search</p> <p>23 December 2009</p>	<p>Date of mailing of the international search report</p> <p><b>19 JAN 2010</b></p>																			
<p>Name and mailing address of the ISA/US</p> <p>Mail Stop PCT, Attn: ISA/US, Commissioner for Patents P.O. Box 1450, Alexandria, Virginia 22313-1450 Facsimile No. 571-273-3201</p>	<p>Authorized officer:</p> <p>Blaine R. Copenheaver</p> <p>PCT Helpdesk: 571-272-4300 PCT OSP: 571-272-7774</p>																			