

Oct. 14, 1930.

G. W. BURCHETT

1,778,308

ACOUSTIC DEVICE

Filed Feb. 5, 1924

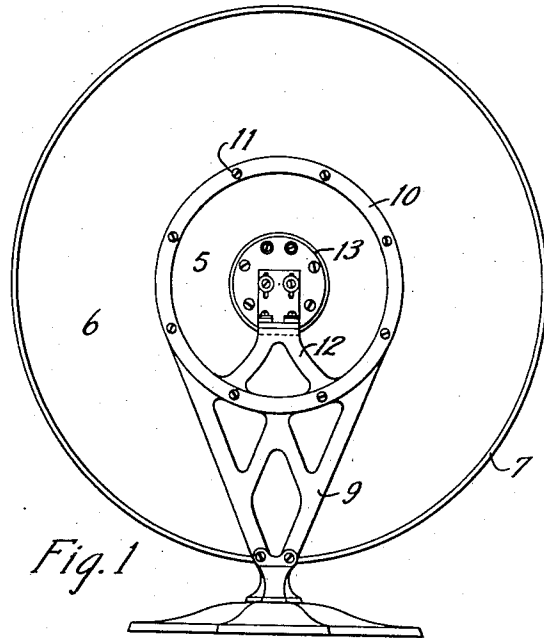

Fig. 1

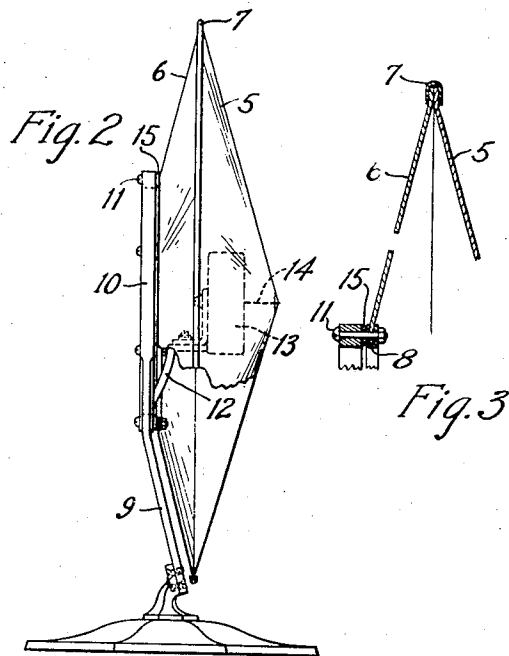

Fig. 2

Fig. 3

Inventor:
George W. Burchett,
by E. W. Adams, Atty

UNITED STATES PATENT OFFICE

GEORGE W. BURCHETT, OF PEEKSKILL, NEW YORK, ASSIGNOR TO WESTERN ELECTRIC COMPANY, INCORPORATED, OF NEW YORK, N. Y., A CORPORATION OF NEW YORK

ACOUSTIC DEVICE

Application filed February 5, 1924. Serial No. 690,803.

This invention relates to acoustic apparatus and its object is to provide a simple, sturdy and efficient construction and mounting for conical or similar diaphragms or sound radiating members.

In general, this invention comprises a frusto-conical section attached to the base of the conical diaphragm and rigidly supported at its smaller diameter.

This invention can be clearly understood from a consideration of the following detailed description in connection with the drawing in which: Fig. 1 is a rear view of a loud speaking receiver employing this invention; Fig. 2 is a side elevation of the device shown in Fig. 1; and Fig. 3 is a detailed section of the diaphragm and frusto-conical support.

The diaphragm 5 is conical in shape and made of some light elastic material such as paper. Attached to its base is a frusto-conical supporting member 6 preferably made of the same material as the diaphragm 5. The frusto-conical member 6 serves as a support for the member 5 and cooperates with it in reproducing the sound vibrations. The conical and frusto-conical sections are fastened together at their outer edges, preferably by means of an aluminum ring 7 of U-shaped cross section clamped around the two sections as is shown in detail in Fig. 3. This ring not only serves as a simple and efficient means of clamping the two sections together and stiffening their edges but also provides mechanical protection for the diaphragm. Another ring of metal 8 is clamped around the edge of the frusto-conical section at its smaller diameter. This serves to stiffen this section and to provide means of mounting.

The diaphragm is supported by a stand 9 on which is mounted a cast metal ring 10. The frusto-conical section is securely attached to this supporting ring by means of bolts 11. In order to prevent chattering, the metal ring 8 is kept out of contact with the supporting ring 10 throughout the major part of its circumference and in the form of this invention shown, this is accomplished

by means of bosses 15 provided at each bolt-hole.

Attached to the supporting ring 10 is a bracket 12 on which is mounted an actuating device 13 which transmits vibrations to the diaphragm through a rod 14 attached to the diaphragm at its apex. This actuating device may be any of the well-known electromagnetic types but is preferably of the type described in U. S. Patent No. 1,365,898 granted to H. C. Edgerton January 18, 1921.

This invention has been described in connection with a loud speaking receiver but it should be understood that it is readily applicable to other devices such as phonograph reproducers or recorders by substituting actuating devices which are well known in the art.

What is claimed is:

1. An acoustic device comprising a conical diaphragm, driving means attached to the apex thereof, a frusto-conical support having one edge attached to said diaphragm and means for rigidly supporting said frusto-conical support at its outer edge.

2. An acoustic device comprising a conical diaphragm, a frusto-conical support having its base attached to the base of said diaphragm and a rigid ring securely fastened to the frusto-conical support at its smaller end.

3. An acoustic device comprising a conical diaphragm, a frusto-conical support having its outer edge attached to the base of said diaphragm, a metal ring clamped around the inner edge of said frusto-conical support and a rigid ring firmly attached to said frusto-conical support at its inner edge.

4. An acoustic device comprising a conical diaphragm, a frusto-conical support for said diaphragm, means for clamping together the bases of said conical diaphragm and said frusto-conical support and means for rigidly supporting said frusto-conical support.

5. An acoustic device comprising a conical diaphragm, a frusto-conical support for said diaphragm, a metal ring clamping together the edges of the bases of said diaphragm and said frusto-conical support and a base rig-

idly attached to the smaller end of said frusto-conical support.

6. An acoustic device comprising a conical diaphragm, a frusto-conical section made of material of substantially the same mechanical properties as said diaphragm, means for fastening together the bases of said conical diaphragm and said frusto-conical section, a metal ring clamped around the edge of said frusto-conical section at its smaller end, an annular support for said diaphragm rigidly attached to said metal ring and means for preventing the edge of said frusto-conical section from chattering.

7. An acoustic device comprising a conical diaphragm, a frusto-conical support attached to said diaphragm at its base, a metal ring clamped to the edge of the smaller end of said frusto-conical support, an annular support firmly attached to the smaller end of said frusto-conical support at a plurality of points and means for preventing said metal ring from coming in contact with said annular support at points other than said points of attachment.

8. An acoustic device comprising a conical diaphragm, a frusto-conical support for said diaphragm, a metal ring clamping together the edges of the bases of said conical diaphragm and said frusto-conical support, a metal ring clamped to the edge of the smaller end of said frusto-conical support, an annular support firmly attached to the smaller end of said frusto-conical support at a plurality of points and bosses on said annular support for preventing said metal ring from coming in contact with said annular support at points other than said points of attachment.

9. An acoustic device comprising a conical diaphragm of fibrous material, a section of fibrous material for supporting said diaphragm and a metal band clamped on the edge of said diaphragm at the point of attachment to said supporting section.

10. An acoustic device comprising a conical diaphragm, a frusto-conical support for said diaphragm, and a U shaped ring of aluminum clamping together the edges of the bases of said conical diaphragm and said frusto-conical support.

11. An acoustic device comprising a conical diaphragm, a frusto-conical support having its base attached to the base of said conical diaphragm, a rigid ring securly fastened to said frusto-conical support at its smaller end, an actuating device having a vibrating member attached to said conical diaphragm at its apex and a supporting member attached to said rigid ring for supporting said actuating device.

12. An acoustic device comprising a conical diaphragm, a frusto-conical section having one edge attached to said conical diaphragm, means for reinforcing the other edge of said

frusto-conical section, and means for rigidly mounting said reinforced edge.

13. An acoustic device comprising a conical section, driving means connected to the apex thereof, a frustum shaped section arranged to have its base attached to the base of said conical section, means for connecting said sections at their bases, and a rigid member to which the smaller end of the frustum-shaped section is attached, said member having an opening therein through which air may pass.

14. An acoustic device comprising a conical diaphragm, a frustum shaped support for said diaphragm, means for securing together the bases of said conical diaphragm and said frustum shaped support, means for rigidly supporting said frustum shaped support and driving means connected to the apex of said diaphragm for moving it toward and away from said supporting means.

15. An acoustic device comprising a conical diaphragm, a frusto-conical section of material of mechanical properties similar to those of said diaphragm, means for fastening together the bases of said conical diaphragm and said frusto-conical section, means for rigidly supporting the other edge of said frusto-conical section, and means for reinforcing said last mentioned edge of said frusto-conical section to prevent said edge from chattering.

16. An acoustic device comprising a diaphragm, an apertured support having its edge attached to said diaphragm so as to form with said diaphragm a hollow body, means for rigidly mounting said support at its aperture, and means connected to said diaphragm for imparting vibrational forces to said diaphragm to move it toward and away from said rigid mounting, said means being positioned within said hollow body.

17. An acoustic device according to claim 16 in which said apertured support is composed of material of substantially the same mechanical properties as said diaphragm.

18. In a sound reproducer, a rigid ring support, a cone-shaped diaphragm of greater edge diameter than said support, continuous, flexible sheet material uniting the edge of said diaphragm to said support, and means for applying vibrations representing sound to said diaphragm.

19. A sound producer comprising light flexible material formed into a first and a second surface of revolution, said second surface of revolution having its edge united to the edge of said first surface of revolution, a rigid support-member secured to the other edge of said second surface, and actuating means operatively connected to a point in said first surface.

20. In an acoustic device, a dish-shaped diaphragm, a dish-shaped support having an opening therein, a rigid member having a

configuration substantially the same as the opening in said dish-shaped member for mounting said dish-shaped member thereon, and means for fastening the peripheries of said diaphragm and said dish-shaped member together, said diaphragm and dish-shaped member forming an air chamber.

21. In an acoustical device, a diaphragm, a flexible support secured thereto adjacent its periphery and combining therewith to form an air chamber, a centrally located ring forming a rigid support for said flexible support and also forming an entrance to said chamber, and means carried by said ring and connected to the center of said diaphragm for vibrating the same.

22. A loud speaker comprising a driving device, a hollow member connected thereto having an opening in one wall thereof, and means for rigidly mounting said member at said opening so that all points of said member are free to vibrate except at said opening, said member forming with said means a chamber for air, said means having an opening therein for the egress and ingress of air in response to vibrations imparted to said member by said driving device.

In witness whereof, I hereunto subscribe my name this 2 day of February, A. D. 1924.

GEORGE W. BURCHETT.

CERTIFICATE OF CORRECTION.

Patent No. 1,778,308.

Granted October 14, 1930, to

GEORGE W. BURCHETT.

It is hereby certified that error appears in the printed specification of the above numbered patent requiring correction as follows: Page 1, line 75, claim 1, for "outer" read other; page 2, line 45, claim 10, for the misspelled word "devic" read device; line 88, claim 15, for the compound word "fusto-conical" read frusto-conical; line 129, claim 20, for the word "support" read member, and line 130, for "member" read support; and that the said Letters Patent should be read with these corrections therein that the same may conform to the record of the case in the Patent Office.

Signed and sealed this 1st day of September, A. D. 1931.

(Seal)

M. J. Moore,
Acting Commissioner of Patents.