



(43) International Publication Date
28 September 2017 (28.09.2017)

(51) International Patent Classification:

E21B 17/02 (2006.01) E21B 43/10 (2006.01)
E21B 23/02 (2006.01)

(21) International Application Number:

PCT/US2016/023812

(22) International Filing Date:

23 March 2016 (23.03.2016)

(25) Filing Language:

English

(26) Publication Language:

English

(71) Applicant: **HALLIBURTON ENERGY SERVICES, INC.** [US/US]; 3000 N. Sam Houston Pkwy E., Houston, TX 77032 (US).

(72) Inventors: **KOHN, Gary, Allen**; 2101 Cannes Drive, Carrollton, TX 75006 (US). **MORENO, Carlos, Alberto**; 1701 E. Hebron Parkway, Apt. 5107, Carrollton, TX 75010 (US). **DAIGLE, Odee, Paul**; 5511 Spring Creek Dr., Sachse, TX 75048 (US). **HUMPHREY, Ryan, Thomas**; 4330 Mckinney Ave., Apt. 6, Dallas, TX 75205 (US).

(74) Agents: **GROSS, Charles, J.** et al.; McGuirewoods LLP, 1750 Tysons Blvd., Suite 1800, Tysons Corner, VA 22102 (US).

(81) Designated States (unless otherwise indicated, for every kind of national protection available): AE, AG, AL, AM, AO, AT, AU, AZ, BA, BB, BG, BH, BN, BR, BW, BY, BZ, CA, CH, CL, CN, CO, CR, CU, CZ, DE, DK, DM, DO, DZ, EC, EE, EG, ES, FI, GB, GD, GE, GH, GM, GT, HN, HR, HU, ID, IL, IN, IR, IS, JP, KE, KG, KN, KP, KR, KZ, LA, LC, LK, LR, LS, LU, LY, MA, MD, ME, MG, MK, MN, MW, MX, MY, MZ, NA, NG, NI, NO, NZ, OM, PA, PE, PG, PH, PL, PT, QA, RO, RS, RU, RW, SA, SC, SD, SE, SG, SK, SL, SM, ST, SV, SY, TH, TJ, TM, TN, TR, TT, TZ, UA, UG, US, UZ, VC, VN, ZA, ZM, ZW.

(84) Designated States (unless otherwise indicated, for every kind of regional protection available): ARIPO (BW, GH, GM, KE, LR, LS, MW, MZ, NA, RW, SD, SL, ST, SZ, TZ, UG, ZM, ZW), Eurasian (AM, AZ, BY, KG, KZ, RU, TJ, TM), European (AL, AT, BE, BG, CH, CY, CZ, DE, DK, EE, ES, FI, FR, GB, GR, HR, HU, IE, IS, IT, LT, LU, LV, MC, MK, MT, NL, NO, PL, PT, RO, RS, SE, SI, SK, SM, TR), OAPI (BF, BJ, CF, CG, CI, CM, GA, GN, GQ, GW, KM, ML, MR, NE, SN, TD, TG).

Declarations under Rule 4.17:

— of inventorship (Rule 4.17(iv))

Published:

— with international search report (Art. 21(3))

(54) Title: BIG BORE RUNNING TOOL QUICK LOCK ADAPTOR

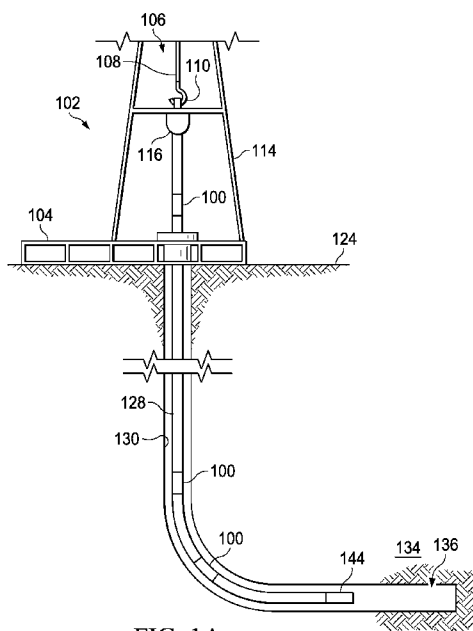

FIG. 1A

(57) Abstract: The disclosed embodiments include a coupler assembly and method for conveying a single piece liner hanger body. In one embodiment, the coupler assembly includes a nut, a load transfer sleeve, a locking dog retainer, a garter spring, a locking dog, a collet, an outer collet mandrel, and a collet prop mandrel. As described herein, components of the coupler assembly are assembled and installed within the inner diameter of the single piece liner hanger body for engaging with a liner hanger sub-assembly attached to a running tool.

BIG BORE RUNNING TOOL QUICK LOCK ADAPTOR

BACKGROUND

[0001] The present disclosure relates generally to equipment utilized and operations performed in conjunction with oil and gas exploration and production, and more particularly to a method and coupler assembly for conveying a single piece liner hanger body.

[0002] Once a well has been drilled, if it is to become a production well, the well must undergo completion. This principally involves preparing the bottom of the hole to the required specifications, running in the production tubing and its associated down hole tools, as well as perforating and stimulating the well. Typically, the lower completion of the well is set across the productive zone using a liner hanger system, which anchors the lower completion to the production casing string.

[0003] The installation of the liner hanger system and these strings presents a variety of challenges. One such challenge is that third party supplied thread connections do not always provide the performance needed to meet the sealing, tensile and compression requirements for the hanger assembly. Third party threads have recently come under close scrutiny during gas testing of liner hangers and have performance issues when gas tight bubble free connections are required.

[0004] Accordingly, as will be described herein, one purpose of the disclosed embodiments is to incorporate new and improved geometry such as a one piece hanger body. Additionally, one advantage of the disclosed embodiments is that it offers a means to easily hydro test critical sealing features that previously required expensive test fixtures. Other aspects and advantages of the disclosed embodiments will be apparent from the following description and the appended claims.

BRIEF DESCRIPTION OF THE DRAWINGS

[0005] Illustrative embodiments of the present invention are described in detail below with reference to the attached drawing figures, which are incorporated by reference herein, and wherein:

5 [0006] FIG. 1A is a diagram of an on-shore well in which a tool string is deployed according to an illustrative embodiment;

[0007] FIG. 1B is a diagram of an off-shore well in which a tool string is deployed according to an illustrative embodiment;

10 [0008] FIG. 2 is a diagram of the inner sub-assembly components of a coupler assembly for conveying a liner hanger to a running tool according to an illustrative embodiment;

[0009] FIGS. 3-14 are diagrams illustrating a method of assembling the inner sub-assembly components of the coupler assembly according to an illustrative embodiment;

[0010] FIGS. 15-24 are diagrams illustrating a method of assembling the outer sub-assembly components of the coupler assembly according to an illustrative embodiment;

15 [0011] FIG. 25 is a diagram of an assembled coupler assembly according to an illustrative embodiment; and

[0012] FIG. 26 illustrates a cross-sectional view of the components of the assembled coupler assembly according to an illustrative embodiment.

20 [0013] The illustrated figures are only exemplary and are not intended to assert or imply any limitation with regard to the environment, architecture, design, or process in which different embodiments may be implemented.

DETAILED DESCRIPTION OF ILLUSTRATIVE EMBODIMENTS

[0014] In the following detailed description of the illustrative embodiments, reference is made to the accompanying drawings that form a part hereof. These embodiments are described in sufficient detail to enable those skilled in the art to practice the claims, and it is understood that other embodiments may be utilized and that logical structural and mechanical changes may be made without departing from the spirit or scope of the disclosed
5 embodiments. To avoid detail not necessary to enable those skilled in the art to practice the embodiments described herein, the description may omit certain information known to those skilled in the art. The following detailed description is, therefore, not to be taken in a
10 limiting sense, and the scope of the illustrative embodiments is defined only by the appended claims.

[0015] Currently, as part of the well completion process, a big bore running tool is used to set a two piece liner hanger consisting of an upper expandable body and a setting sleeve that is threaded to the bottom of it. The illustrative embodiments modify the current big bore
15 running tool to enable conveying of a big bore liner hanger with a single piece hanger body. As will be described, the disclosed embodiments maintains an assembly method known as "top down" build whereby the assembly begins with the topmost components and parts are added as you move towards the bottom of the running tool.

[0016] Beginning with FIG. 1A, a schematic view of a rig 104 in which a tool string 128 is deployed that includes a coupler assembly 100 is presented in accordance with an illustrative embodiment. The rig 104 is positioned onshore at a surface 124 of a well 102. The well 102 includes a wellbore 130 that extends from the surface 124 of the well 102 to a
20 subterranean substrate or formation 134. Tool string 128 may deploy running tools used to place or set downhole equipment 144 such as, but not limited to, liner hangers, plugs and packers. For instance, in one embodiment, the coupler assembly 100 may be used to convey or set a liner hanger to a running tool.

[0017] Similarly, FIG. 1B illustrates a schematic view of an offshore platform 142 operating a tool string 128 that includes the coupler assembly 100 according to an illustrative embodiment. The coupler assembly 100 in FIG. 1B may be deployed in a sub-
30 sea well 138 accessed by the offshore platform 142. The offshore platform 142 may be a floating platform or may instead be anchored to a seabed 140.

[0018] FIGS. 1A-1B each illustrate possible uses or deployments of the coupler assembly 100, which in either instance may be used in tool string 128 to deploy the

downhole equipment 144. In the embodiments illustrated in FIG. 1A and 1B, the wellbore 130 has been formed by a drilling process in which dirt, rock and other subterranean material has been cut from the formation 134 by a drill bit operated via a drill string to create the wellbore 130. During or after the drilling process, a portion of the wellbore may be cased with a casing (not illustrated in FIGS. 1A and 1B). In other embodiments, the wellbore may be maintained in an open-hole configuration without casing.

[0019] The tool string 128 may include sections of tubing, each of which are joined to adjacent tubing by threaded or other connection types, such as coupler assembly 100. The tool string 128 may refer to the collection of pipes, mandrels or tubes as a single component, or alternatively to the individual pipes, mandrels, or tubes that comprise the string. The term tool string is not meant to be limiting in nature and may include a running tool or any other type of tool string used to deploy the downhole equipment 144 in the wellbore. In some embodiments, the tool string 128 may include a passage disposed longitudinally in the tool string 128 that is capable of allowing fluid communication between the surface 124 of the well 102 and a downhole location 136. It is noted that the coupler assembly 100 described herein may be used to couple tubing segments in any suitable tool string, including, for example, a running tool for deploying a liner hanger.

[0020] The lowering of the tool string 128 may be accomplished by a lift assembly 106 associated with a derrick 114 positioned on or adjacent to the rig 104 or offshore platform 142. The lift assembly 106 may include a hook 110, a cable 108, a traveling block (not shown), and a hoist (not shown) that cooperatively work together to lift or lower a swivel 116 that is coupled an upper end of the tool string 128. The tool string 128 may be raised or lowered as needed to add additional sections of tubing to the tool string 128 to position the distal end of the tool string 128 at the downhole location 136 in the wellbore 130.

[0021] Referring now to the detail description of the coupler assembly 100, FIG. 2 illustrates the inner sub-assembly components of the coupler assembly 100 in accordance with one embodiment. In this illustrative embodiment, the coupler assembly 100 is used for conveying a liner hanger 88 to a running tool 90 (illustrated in FIG. 18). The inner sub-assembly components of the coupler assembly 100 include a nut 47, a load transfer sleeve 46, a locking dog retainer 45, a garter spring 49, a locking dog 48, a collet 44, and an outer collet mandrel 43. As will be further described, once the inner sub-assembly of the coupler assembly 100 is assembled, the assembled inner sub-assembly of the coupler assembly 100 is inserted into the liner hanger 88.

[0022] FIGS. 3-15 illustrate a method of assembling the inner sub-assembly components of the coupler assembly 100 according to an illustrative embodiment. The assembly method starts with FIG. 3 where the collet 44 is positioned over the outer collet mandrel 43. The collet 44 comprises a set of collet fingers 44f on one end and a threaded outer diameter on the other end. A set of apertures on the collet 44 is aligned with holes on the outer collet mandrel 43. In one embodiment, the holes on the outer collet mandrel 43 is threaded to enable a set of threaded screws 78 to be received through the set of apertures on the collet 44 and into the holes on the outer collet mandrel 43 for coupling the collet 44 to the outer collet mandrel 43 as illustrated in FIG. 4.

[0023] Next, the locking dog 48 is positioned next to the upper end of the collet 44 as shown in FIG. 5. The garter spring 49 is installed onto the locking dog 48 to keep it in place as illustrated in FIG. 6. The locking dog retainer 45 is then threaded to the collet 44 over the locking dog 48 and the garter spring 49 as shown in FIG. 7. The load transfer sleeve 46 is then installed over the locking dog retainer 45 and the collet 44. The load transfer sleeve 46 abuts a raised edge of the set of collet fingers 44f of the collet 44 as shown in FIG. 8.

[0024] The nut 47 is then threaded onto the top end of the outer collet mandrel 43 as shown in FIG. 9. In one embodiment, an O-ring 58 is placed in the outer diameter of nut 47. The O-ring 58 is compressed during assembly between the nut 47 and the inside of liner hanger 88 creating a seal at the interface as shown in FIG. 13-14. A set of screws 70 is installed to secure the nut 47 to the outer collet mandrel 43 as shown in FIG. 10 to complete the assembly process of the inner sub-assembly components of the coupler assembly 100.

[0025] The assembled inner sub-assembly of the coupler assembly 100 is then inserted into the bottom end of the liner hanger 88 as indicated in FIG. 11. As the coupler assembly 100 is inserted into the bottom end of the liner hanger 88, the set of collet fingers 44f of the collet 44 will collapse down to allow the collet 44 to enter the bottom end of the liner hanger 88 as illustrated in FIGS. 12 and 13.

[0026] FIG. 13 illustrates a cross section of the assembled inner sub-assembly of the coupler assembly 100 as it is being inserted into the bottom end of the liner hanger 88. As shown, the set of collet fingers 44f of the collet 44 is depressed as the collet 44 is fully inserted into the bottom end of the liner hanger 88. In one embodiment, the outer collet mandrel 43 is long enough to allow the assembled inner sub-assembly of the coupler assembly 100 to be manipulated by hand allowing the load bearing collet fingers 44f to engage mating features near the bottom of the liner hanger 88 machined into the inner

diameter of the liner hanger 88 as illustrated in FIG. 14. In some embodiments, a circular pattern of radially drilled holes at the bottom end of the outer collet mandrel 43 can accept a steel bar that aids the application of torque when hand fitting the load bearing features of the collet 44 (i.e., the collet fingers 44f) into the mating features in the liner hanger 88. In certain embodiments, the outside diameter features at the lower end of the outer collet mandrel 43 are much smaller than the inside diameter of the liner hanger 88 and allows for visual inspection to determine if the collet fingers 44f have properly deployed into the mating features in the liner hanger 88.

[0027] Once the collet fingers 44f have properly deployed into the mating features in the liner hanger 88, a collet prop mandrel 50 is inserted into the bottom end of the liner hanger 88 as indicated in FIG. 15. At its top end, the collet prop mandrel 50 includes a section of ridges for mating with the collet fingers 44f in the inner sub-assembly of the coupler assembly 100. In the depicted embodiment, the collet prop mandrel 50 also includes an O-ring 80 located in the inner diameter at the top end, two O-rings 58 around its outer diameter following the ridged section, and an O-ring 81 located in the inner diameter at the bottom end of the collet prop mandrel 50.

[0028] The collet prop mandrel 50 is axially disposed until the collet 44 is propped and the collet prop mandrel 50 shoulders against the outer collet mandrel 43 with a portion of the collet prop mandrel 50 extending out from the bottom of the liner hanger 88 as illustrated in the cross section shown in FIG. 16. O-ring 80 is compressed during assembly between the collet prop mandrel 50 and the outside of outer collet mandrel 43 creating a seal at the interface as shown in FIG. 16. Two O-rings 58 are compressed during assembly between the collet prop mandrel 50 and the inside of liner hanger 88 creating a seal at the interface as shown in FIG. 16.

[0029] Two threaded hollow plugs 79 is then inserted into test ports in the collet prop mandrel 50 that are aligned with apertures in the outer collet mandrel 43 for securing the collet prop mandrel 50 to the inner sub-assembly of the coupler assembly 100 to complete the liner hanger coupler assembly 100 as illustrated in FIG. 17.

[0030] The new two piece coupler assembly 100 is designed to work as a unitized component axially disposed between the top face of the nut 47 and a shoulder on the locking dog retainer 45 in like fashion with existing big bore running tool features. For instance, FIG. 18 illustrates an existing big bore running tool 90 with a liner hanger sub-assembly 40 attached onto the bottom of the running tool 90. In the depicted embodiment, the liner

hanger sub-assembly 40 also includes an O-ring 55 located on the outer diameter at the top end. Using the running tool 90, the liner hanger sub-assembly 40 is inserted into the top end of the liner hanger 88. The liner hanger sub-assembly 40 is inserted until it is completely engaged with the outer collet mandrel 43 that was previously inserted into the bottom end of the liner hanger 88. A portion of the liner hanger sub-assembly 40 extends beyond the bottom end of the collet prop mandrel 50 as indicated in FIG. 19. O-ring 55 is compressed during assembly between the liner hanger sub-assembly 40 and the inside of outer collet mandrel 43 creating a seal at the interface as shown in FIG. 19. O-ring 81 is compressed during assembly between the liner hanger sub-assembly 40 and the inside of collet prop mandrel 50 creating a seal at the interface as shown in FIG. 19.

[0031] FIG. 20 illustrates the final components needed to complete installation of the liner hanger 88 to the liner hanger sub-assembly 40. First, a set of plugs 41 are inserted into the grooved castle turret features at the lower end of the collet prop mandrel 50 to torque lock it to the liner hanger sub-assembly 40 as illustrated in FIG. 21. An O-ring 64 is then installed over the set of plugs 41 to secure the plugs in place as illustrated in FIG. 22.

[0032] A retainer nut 42 is then threaded onto the liner hanger sub-assembly 40 to secure it to the collet prop mandrel 50 as shown in FIG. 23. Finally, a set of screws 70 are then installed into the retainer nut 42 to secure it to the liner hanger sub-assembly 40 as illustrated in FIG. 24. The liner hanger installation is complete at this point.

[0033] Additional parts 62 may be added to the end of the liner hanger sub-assembly 40 to build up the running tool 90 as illustrated in FIG. 25. A cross-sectional view of the completed liner hanger installation of FIG. 25 is illustrated in FIG. 26

[0034] Accordingly, the above disclosure describes a coupler assembly 100 that may be used for conveying a single piece liner hanger to a running tool. While the fundamental appearance of the big bore running tool changes little upon first glance, the disclosed embodiments provide several advantages over the current design. One advantage is that it maintains the "modular" design principals first incorporated into the big bore running tool by adapting existing big bore components such as the collet, load transfer sleeve, locking dogs and the upper nut for use with a single piece liner hanger. For instance, using the existing load bearing geometry of the collet is critical given the time and the amount of money spent to validate and proof test many different sized hangers. Additionally, the disclosed embodiments replace a one piece outer collet mandrel with two pieces that form a

similar silhouette and accomplish the same task to prop and unprop the collet with respect to the same grooves and mill features but in the new one piece liner hanger body.

[0035] Another advantage of the disclosed embodiments is that it offers a means to easily hydro test critical sealing features that previously required expensive test fixtures. In other words, the running tool now has a built in test port for O-ring seal hydro testing, which saves design time and cost. For instance, as described above, two O-rings, instead of one, now form a seal between the collet prop mandrel and the inner diameter of the liner hanger. A pressure port located between the two O-rings communicates to a sealed annular chamber bounded by the inner collet mandrel and the outer collet mandrel sub assembly and O-rings that are placed between the components. The only access to this annular volume is via two threaded communication ports machined perpendicular into the outer diameter of the outer collet mandrel sub assembly at the bottom. These threaded access ports provide a new means to hydro test the O-ring sealing the bore of the liner hanger with the outer collet mandrel sub assembly as well as the two other O-rings that require hydro testing prior to running the tool for a job.

[0036] Moreover, the disclosed embodiments maintain a "Top Down" assembly of the running tool. For example, in accordance with the disclosed embodiments, the collet is inserted from the bottom up keeping sharp edges away from friction reducing coatings on the inner diameter of the liner hanger.

[0037] It should be apparent from the foregoing that the disclosed embodiments have significant advantages over current art. While the embodiments are shown in only a few forms, the embodiments are not limited but are susceptible to various changes and modifications without departing from the spirit thereof.

[0038] As used within the written disclosure and in the claims, the terms "including" and "comprising" are used in an open-ended fashion, and thus should be interpreted to mean "including, but not limited to". Unless otherwise indicated, as used throughout this document, "or" does not require mutual exclusivity. In addition, as used herein, the singular forms "a", "an" and "the" are intended to include the plural forms as well, unless the context clearly indicates otherwise.

[0039] Unless otherwise specified, any use of any form of the terms "connect," "engage," "couple," "attach," "communicate," or any other term describing an interaction between elements is not meant to limit the interaction to direct interaction between the elements and may also include indirect interaction between the elements described.

[0040] Further, the steps of the methods described herein may be carried out in any suitable order, or simultaneously where appropriate. Thus, the scope of the claims should not necessarily be limited by the above description, which is merely provided as examples to enable one of ordinary skill in the art to practice the appended claims.

5 [0041] Moreover, while the appended claims recite specific combinations of features of the disclosed embodiments, other combinations of the claims may include one or more of the following features combine in any number of combinations. In other words, it is intended that the disclosed embodiments support amendments to the appended claims or new claims that combine the various steps or features of the disclosed embodiments in any
10 combination other than those specifically recited in the current appended claims. For example, a claimed method or coupler assembly for conveying a single piece liner hanger body may include one or more of the following clauses, or portions of the following clauses, combine in any number of combinations:

- 15 • assembling an inner sub-assembly portion of a coupler assembly to form an assembled inner sub-assembly portion of the coupler assembly, wherein the inner sub-assembly portion of the coupler assembly comprises a nut, a load transfer sleeve, a locking dog retainer, a garter spring, a locking dog, a collet, and an outer collet mandrel;
- 20 • inserting the assembled inner sub-assembly portion of the coupler assembly through a bottom opening of a single piece liner hanger body until it engages within an inner diameter of the single piece liner hanger body, wherein the assembled inner sub-assembly portion of the coupler assembly is inserted through the bottom opening of the single piece liner hanger body until the collet on the assembled inner sub-assembly portion of the coupler assembly engages with matching collet profile within the inner diameter of the liner hanger;
- 25 • inserting a collet prop mandrel into the bottom opening of the single piece liner hanger body until it engages with the assembled inner sub-assembly portion of the coupler assembly to form the coupler assembly, wherein the collet prop mandrel is inserted into the bottom opening of the single piece liner hanger body over the outer collet mandrel and until it engages with the collet of the assembled inner sub-assembly portion of the
30 coupler assembly to form the coupler assembly;
- securing the collet prop mandrel to the outer collet mandrel of the assembled inner sub-assembly portion of the coupler assembly using a set of threaded hollow plugs; wherein the running tool having the liner hanger sub-assembly installed on the bottom of the

running tool is inserted into the top opening of the single piece liner hanger body until it is completely engaged with the outer collet mandrel of the assembled inner sub-assembly portion of the coupler assembly;

- 5 • inserting a running tool having a liner hanger sub-assembly installed on the bottom of the running tool into a top opening of the single piece liner hanger body until liner hanger sub-assembly engages with the coupler assembly, wherein the running tool having the liner hanger sub-assembly installed on the bottom of the running tool is inserted into the top opening of the single piece liner hanger body until it is completely engaged with the outer collet mandrel of the assembled inner sub-assembly portion of the coupler assembly;
- 10 • securing the liner hanger sub-assembly to the coupler assembly, wherein securing the liner hanger sub-assembly to the coupler assembly includes securing the liner hanger sub-assembly to the collet prop mandrel using a retainer nut;
- compressing an O-ring between the nut and the outer collet mandrel;
- 15 • wherein the coupler assembly includes one or more of the following parts: a nut, a load transfer sleeve, a locking dog retainer, a garter spring, a locking dog, a collet, an outer collet mandrel, and a collet prop mandrel;
- wherein the nut, the load transfer sleeve, the locking dog retainer, the garter spring, the locking dog, the collet, and the outer collet mandrel are assembled together to form an inner sub-assembly portion of the coupler assembly;
- 20 • wherein the collet prop mandrel includes mating features for engaging the inner sub-assembly portion of the coupler assembly within the single piece liner hanger body;
- wherein the coupler assembly includes mating features for engaging a liner hanger sub-assembly attached to a running tool;
- 25 • wherein the coupler assembly includes a retaining nut securing the coupler assembly to the liner hanger sub-assembly;
- wherein the coupler assembly includes a built in test port for O-ring seal hydro testing;
- wherein assembling the inner sub-assembly portion of the coupler assembly to form the assembled inner sub-assembly portion of the coupler assembly comprises one or more of the following steps: installing the collet over the outer collet mandrel; installing the locking dog next to the collet; installing the garter spring onto the locking dog; installing the locking dog retainer to the collet, the locking dog retainer positioned over the locking dog and the garter spring; installing the load transfer sleeve to the collet, the
- 30

load transfer sleeve positioned over the locking dog retainer; and installing the nut to the outer collet mandrel.

[0042] The claims of the current application are as follows:

5

CLAIMS

Claim 1. A method for conveying a single piece liner hanger body, the method comprising:

5 assembling an inner sub-assembly portion of a coupler assembly to form an assembled inner sub-assembly portion of the coupler assembly;

inserting the assembled inner sub-assembly portion of the coupler assembly through a bottom opening of a single piece liner hanger body until it engages within an inner diameter of the single piece liner hanger body;

10 inserting a collet prop mandrel into the bottom opening of the single piece liner hanger body until it engages with the assembled inner sub-assembly portion of the coupler assembly to form the coupler assembly;

inserting a running tool having a liner hanger sub-assembly installed on the bottom of the running tool into a top opening of the single piece liner hanger body until liner hanger sub-assembly engages with the coupler assembly; and

15 securing the liner hanger sub-assembly to the coupler assembly.

Claim 2. The method for conveying a single piece liner hanger body according to claim 1, wherein the inner sub-assembly portion of the coupler assembly comprises a nut, a load transfer sleeve, a locking dog retainer, a garter spring, a locking dog, a collet, and an outer collet mandrel.

20

Claim 3. The method for conveying a single piece liner hanger body according to claim 2, wherein the assembled inner sub-assembly portion of the coupler assembly is inserted through the bottom opening of the single piece liner hanger body until the collet on the assembled inner sub-assembly portion of the coupler assembly engages with matching collet profile within the inner diameter of the liner hanger.

25

Claim 4. The method for conveying a single piece liner hanger body according to claim 2, wherein the collet prop mandrel is inserted into the bottom opening of the single piece liner hanger body over the outer collet mandrel and until it engages with the collet of the assembled inner sub-assembly portion of the coupler assembly to form the coupler assembly.

30

Claim 5. The method for conveying a single piece liner hanger body according to claim 2, further comprising securing the collet prop mandrel to the outer collet mandrel of the assembled inner sub-assembly portion of the coupler assembly using a set of threaded hollow plugs.

5 Claim 6. The method for conveying a single piece liner hanger body according to claim 2, wherein the running tool having the liner hanger sub-assembly installed on the bottom of the running tool is inserted into the top opening of the single piece liner hanger body until it is completely engaged with the outer collet mandrel of the assembled inner sub-assembly portion of the coupler assembly.

10 Claim 7. The method for conveying a single piece liner hanger body according to claim 2, wherein securing the liner hanger sub-assembly to the coupler assembly includes securing the liner hanger sub-assembly to the collet prop mandrel using a retainer nut.

Claim 8. The method for conveying a single piece liner hanger body according to claim 2, wherein the coupler assembly has a built in test port for O-ring seal hydro testing.

15 Claim 9. The method for conveying a single piece liner hanger body according to claim 2, wherein assembling the inner sub-assembly portion of the coupler assembly to form the assembled inner sub-assembly portion of the coupler assembly comprises:

installing the collet over the outer collet mandrel;

installing the locking dog next to the collet;

20 installing the garter spring onto the locking dog;

installing a locking dog retainer to the collet, the locking dog retainer positioned over the locking dog and the garter spring;

installing a load transfer sleeve to the collet, the load transfer sleeve positioned over the locking dog retainer; and

25 installing the nut to the outer collet mandrel.

Claim 10. The method for conveying a single piece liner hanger body according to claim 9, further comprising compressing an O-ring between the nut and the single piece liner hanger body.

Claim 11. A coupler assembly for conveying a single piece liner hanger body to a running tool, the coupler assembly comprising:

- a nut;
- a load transfer sleeve;
- 5 a locking dog retainer;
- a garter spring;
- a locking dog;
- a collet; and
- an outer collet mandrel.

10 Claim 12. The coupler assembly for conveying a single piece liner hanger body to a running tool according to claim 11, wherein the nut, the load transfer sleeve, the locking dog retainer, the garter spring, the locking dog, the collet, and the outer collet mandrel are assembled together to form an inner sub-assembly portion of the coupler assembly.

15 Claim 13. The coupler assembly for conveying a single piece liner hanger body to a running tool according to claim 12, wherein the inner sub-assembly portion of the coupler assembly is inserted into a bottom end of the single piece liner hanger body.

20 Claim 14. The coupler assembly for conveying a single piece liner hanger body to a running tool according to claim 13, wherein the coupler assembly further comprises a collet prop mandrel, the collet prop mandrel having mating features for engaging the inner sub-assembly portion of the coupler assembly within the single piece liner hanger body.

Claim 15. The coupler assembly for conveying a single piece liner hanger body to a running tool according to claim 14, further comprising second mating features for engaging a liner hanger sub-assembly attached to the running tool.

25 Claim 16. The coupler assembly for conveying a single piece liner hanger body to a running tool according to claim 15, further comprising a retaining nut securing the coupler assembly to the liner hanger sub-assembly.

30 Claim 17. The coupler assembly for conveying a single piece liner hanger body to a running tool according to claim 16, further comprising a built in test port for O-ring seal hydro testing.

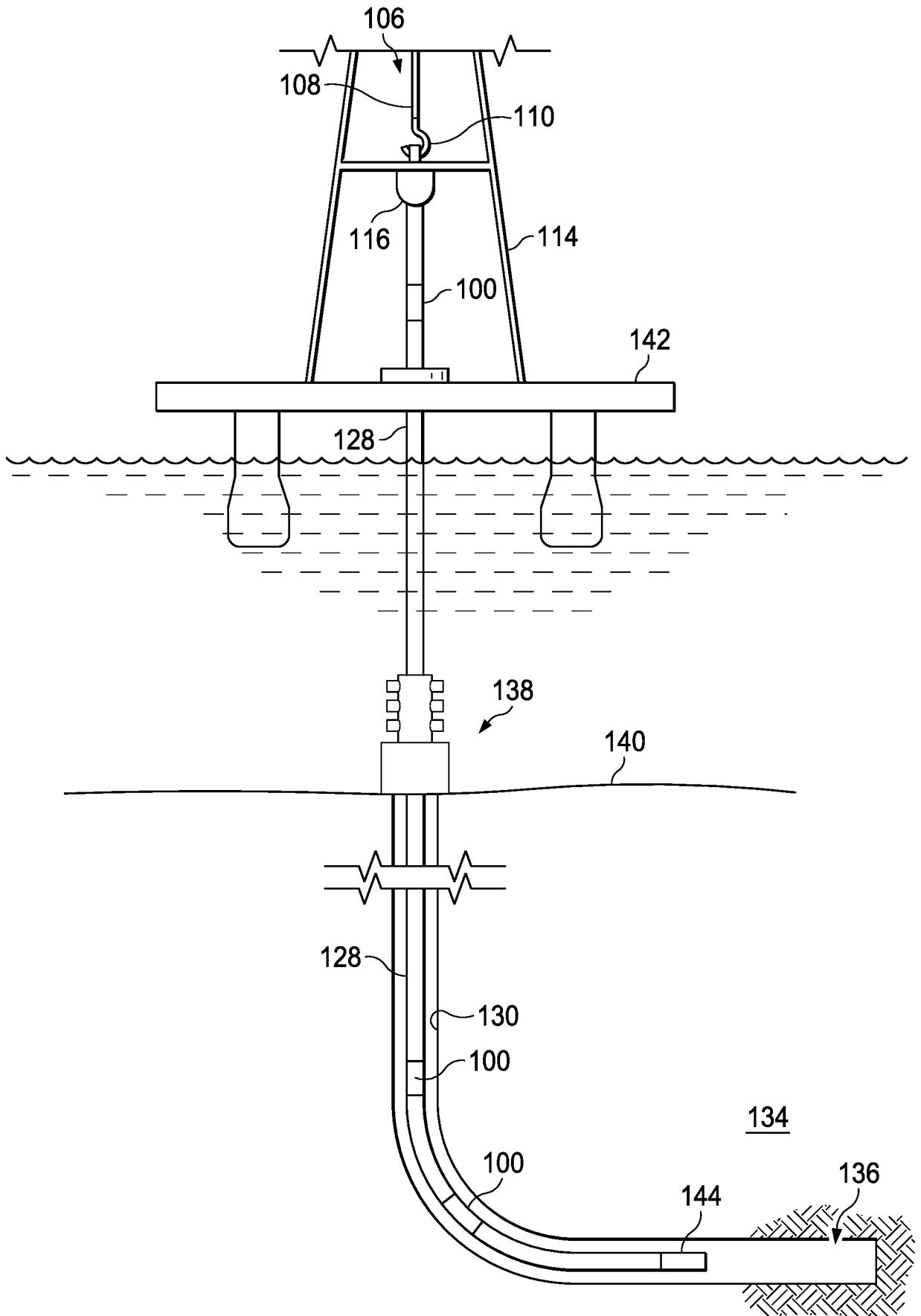

FIG. 1B

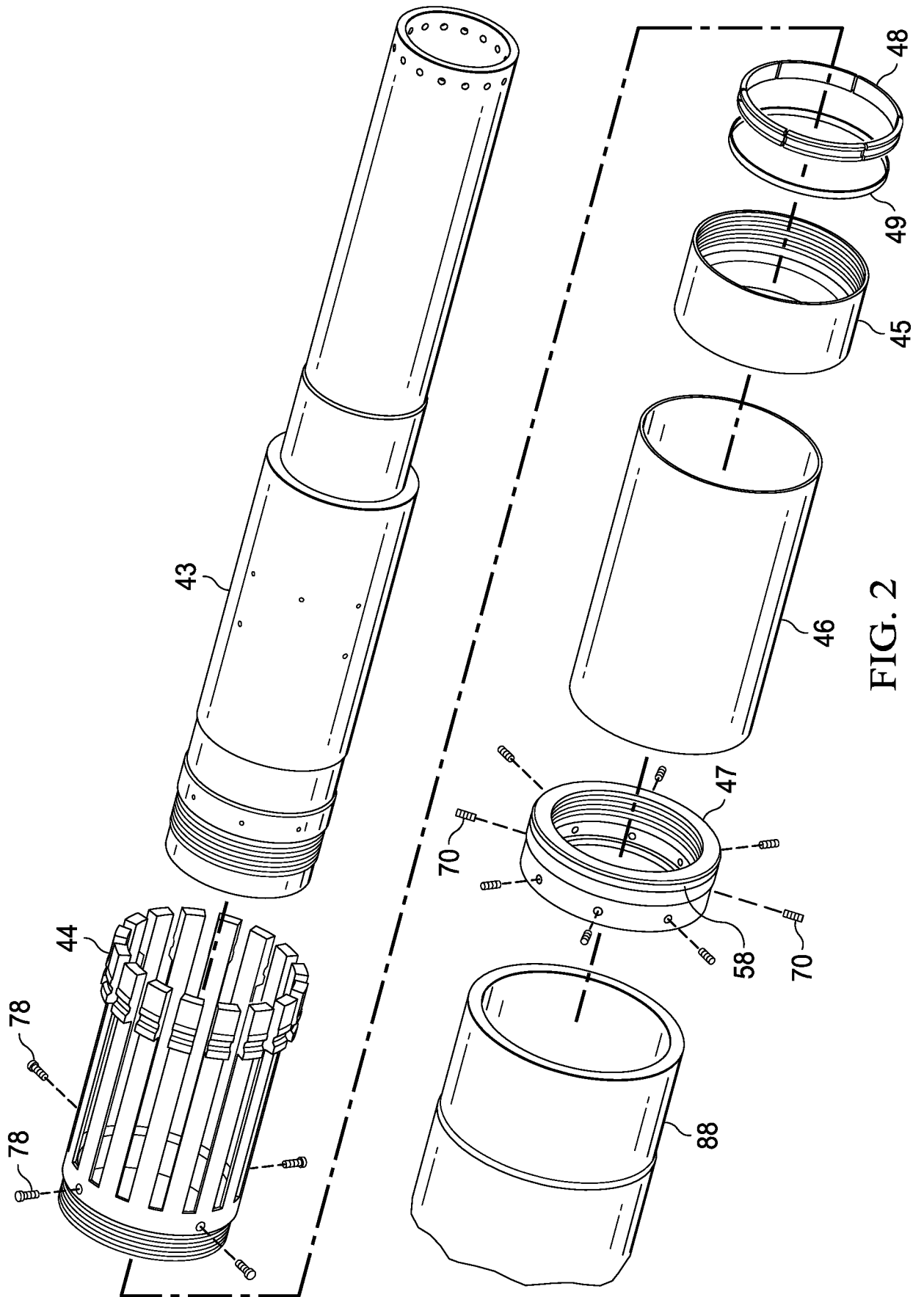

FIG. 2

4/27

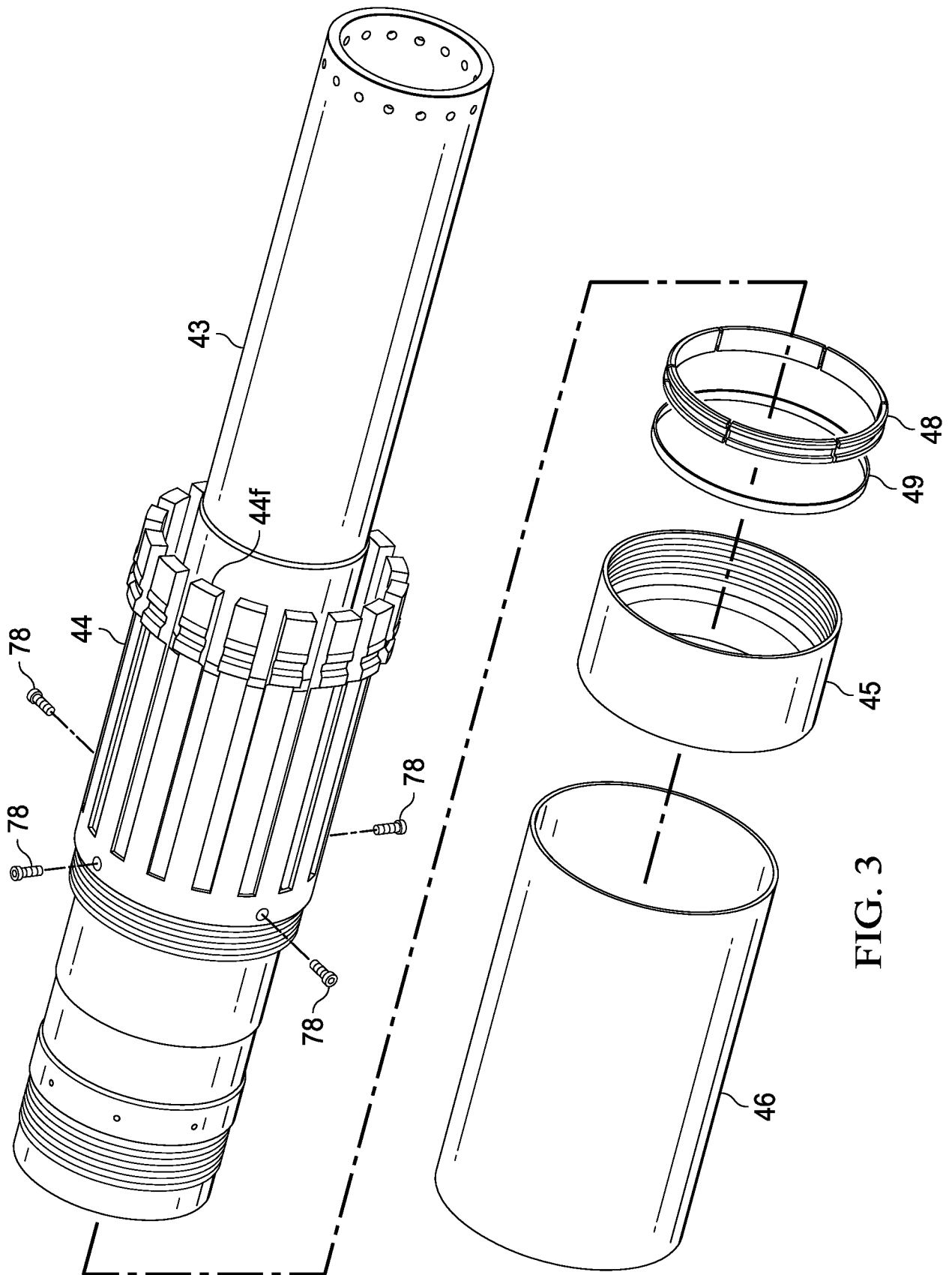

FIG. 3

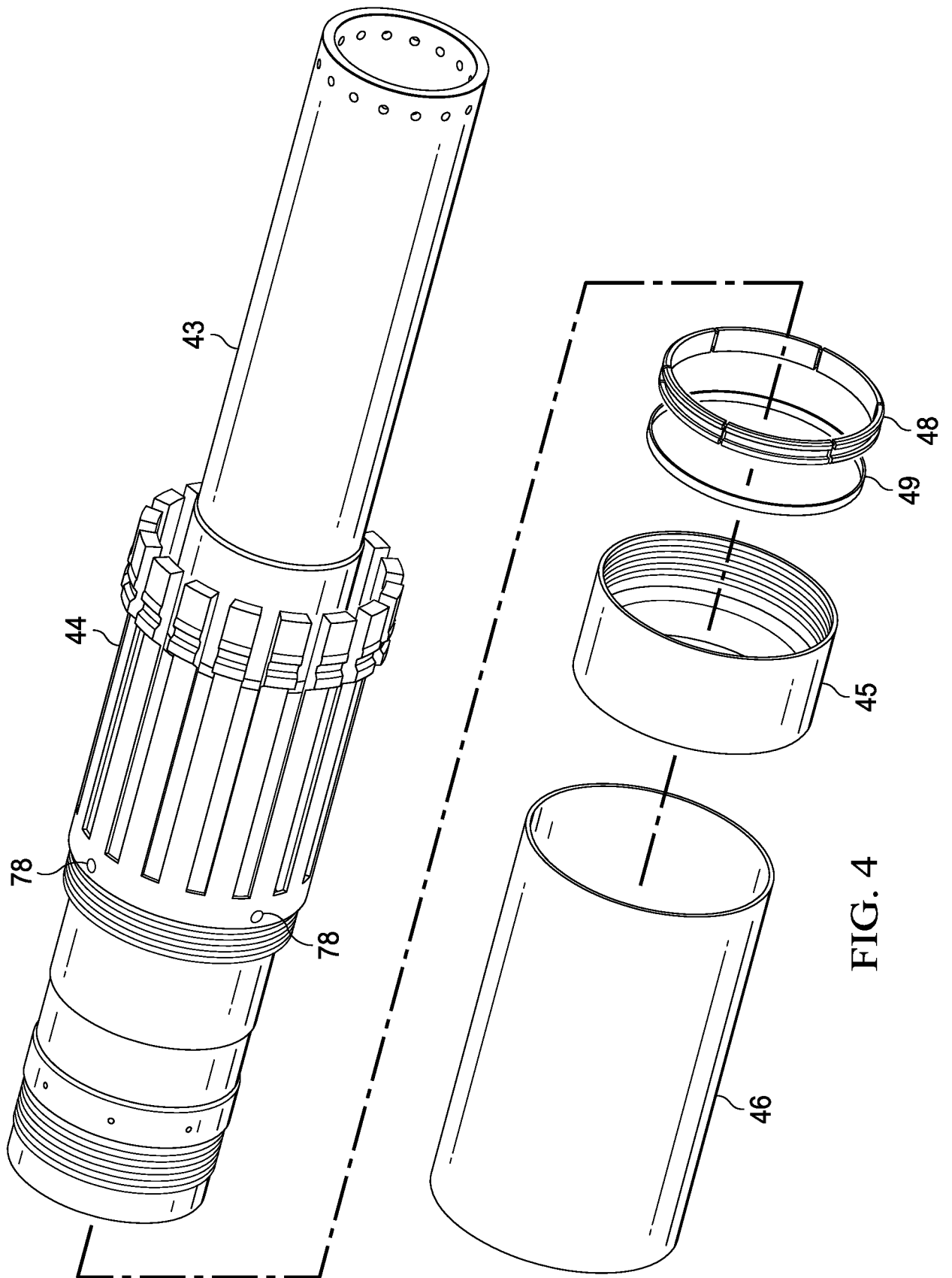

FIG. 4

6/27

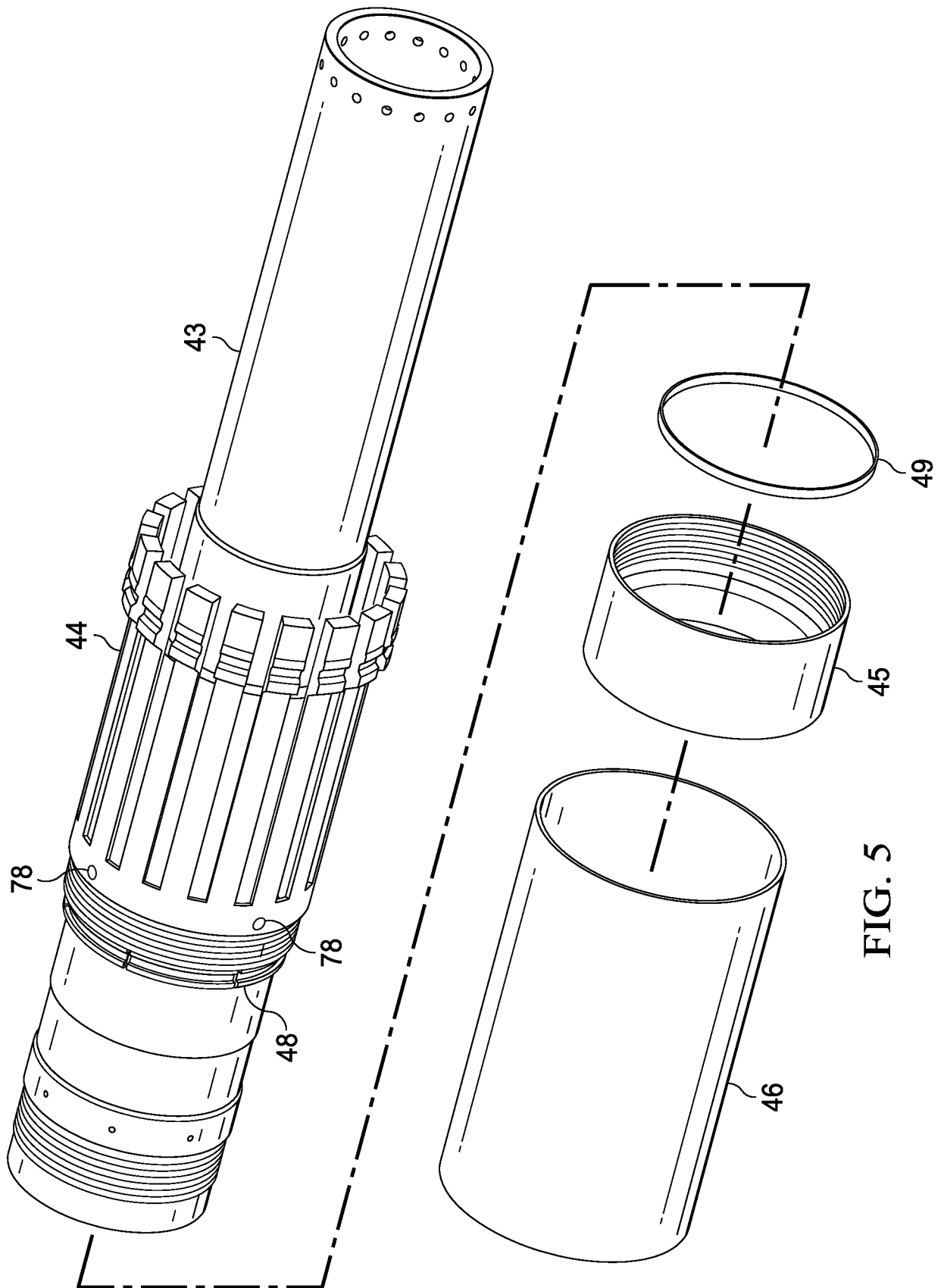

FIG. 5

7/27

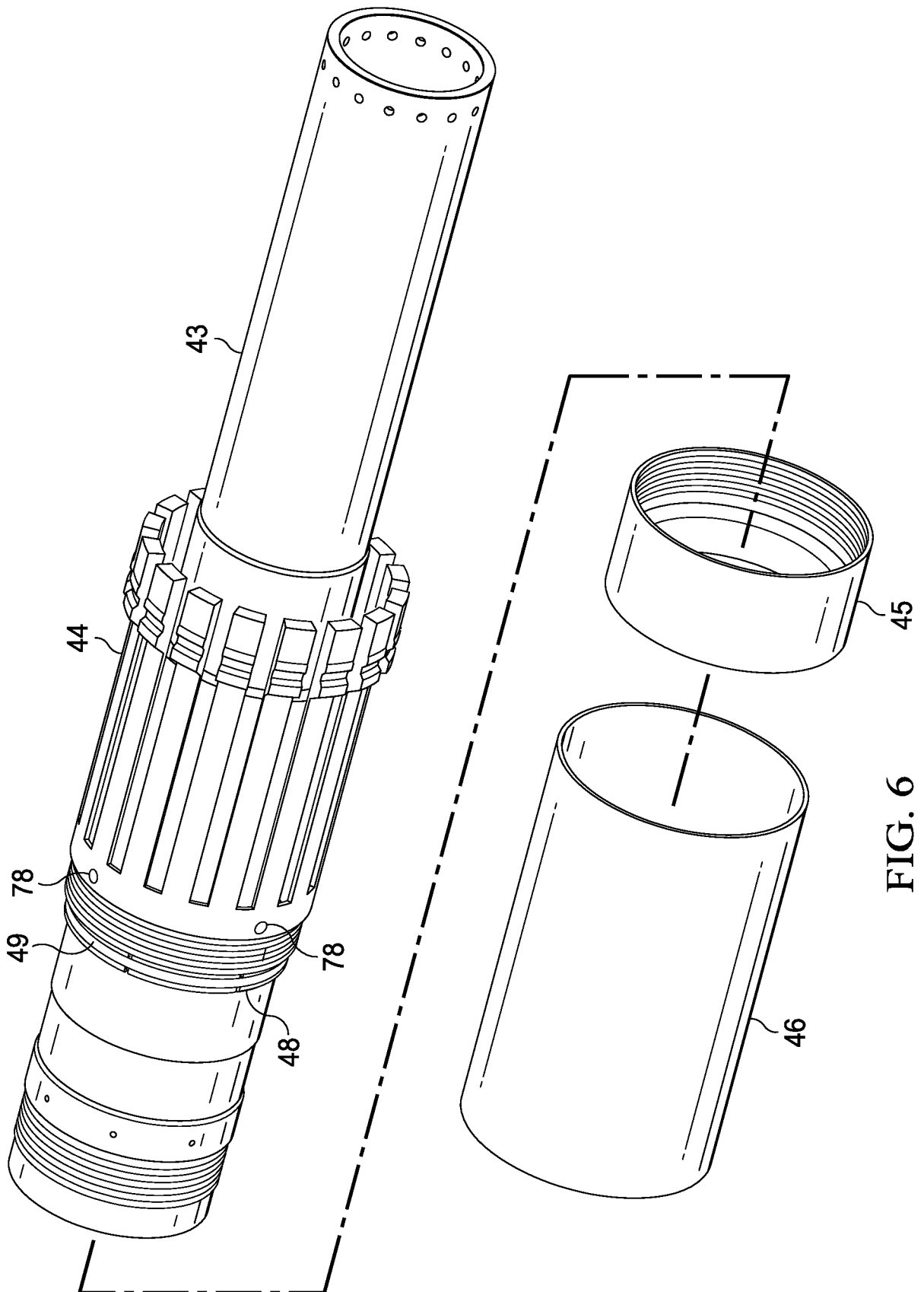

FIG. 6

8/27

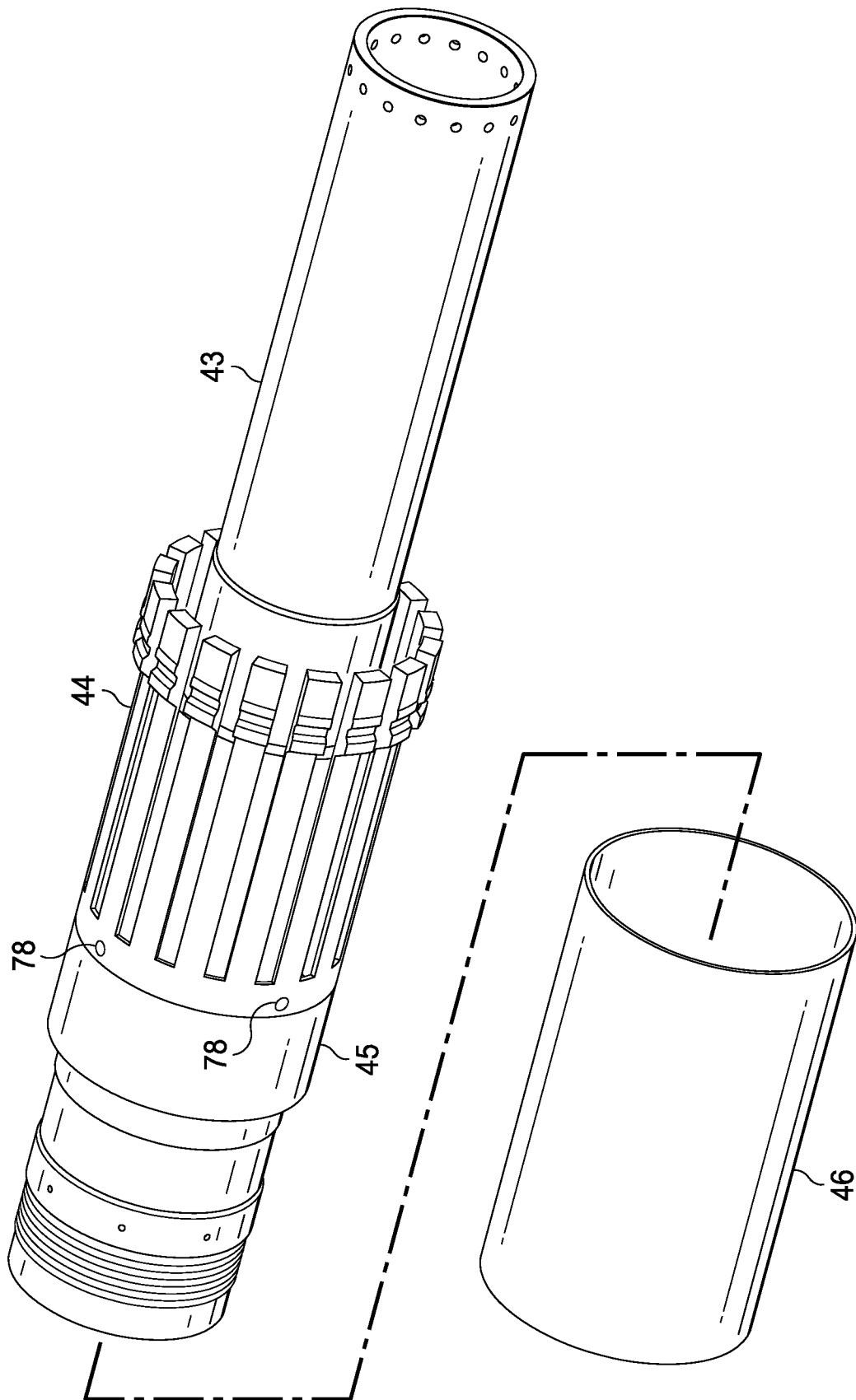

FIG. 7

9/27

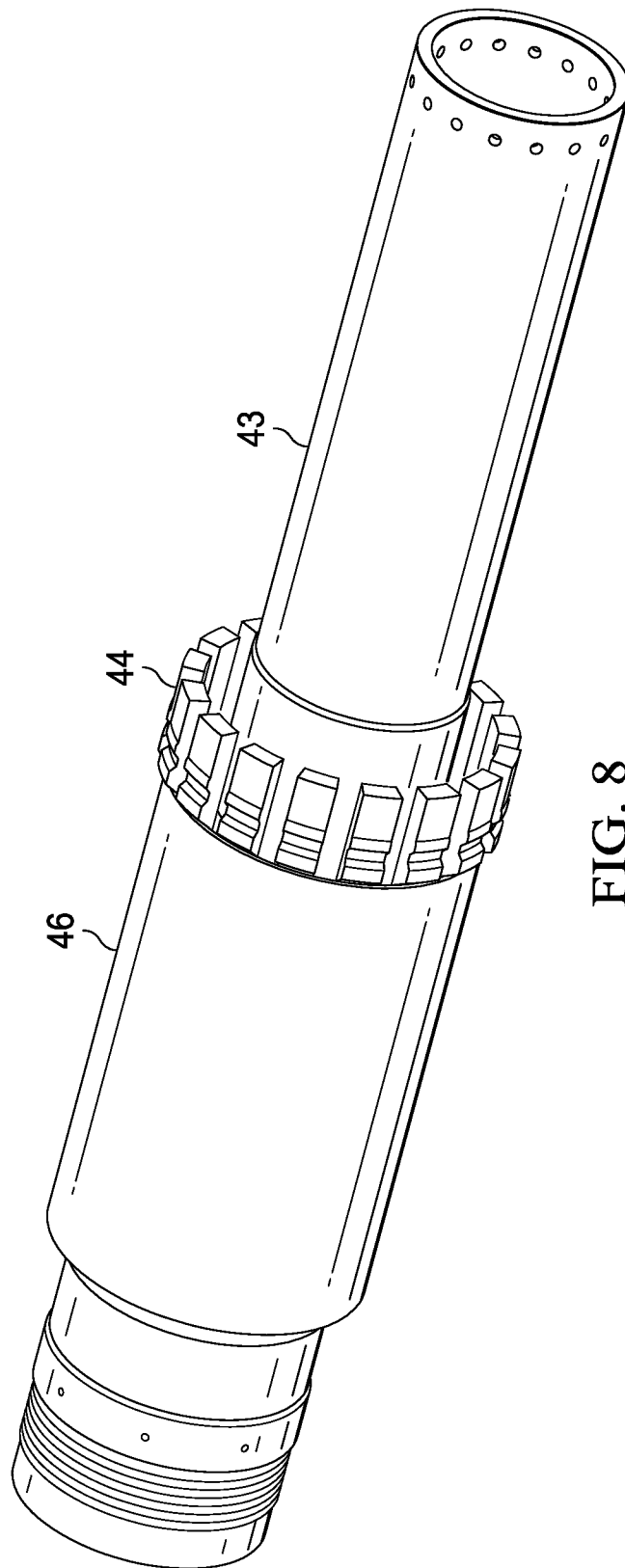

FIG. 8

10/27

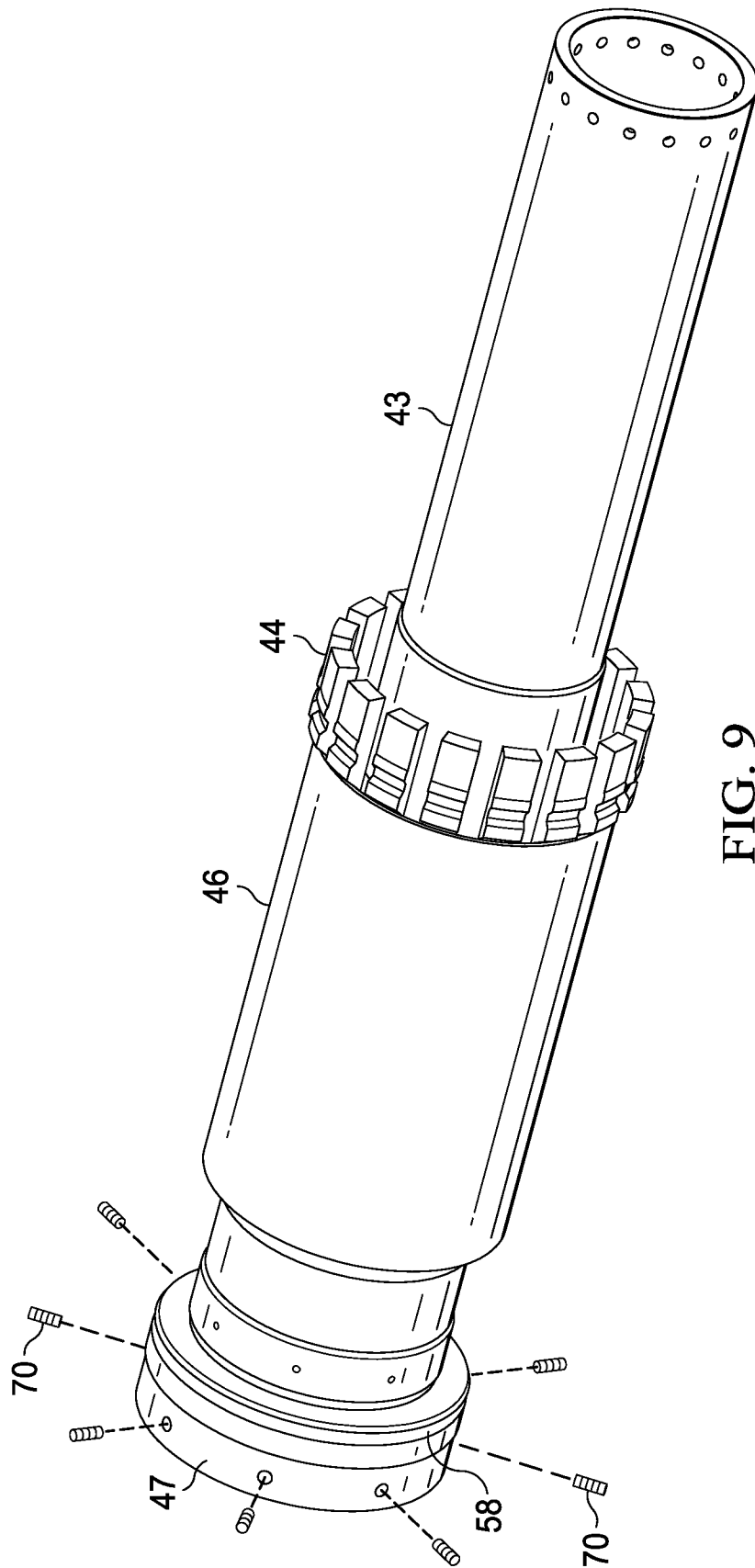

FIG. 9

11/27

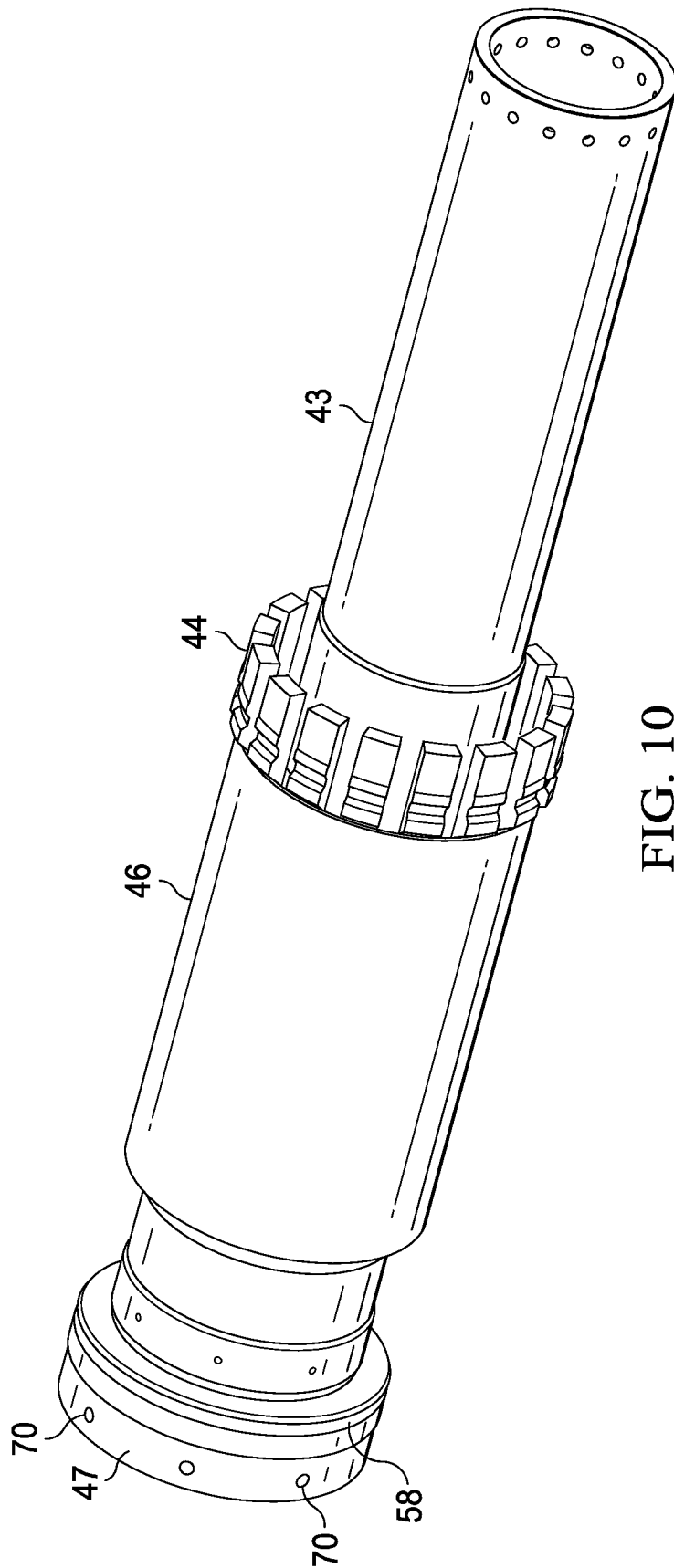

FIG. 10

12/27

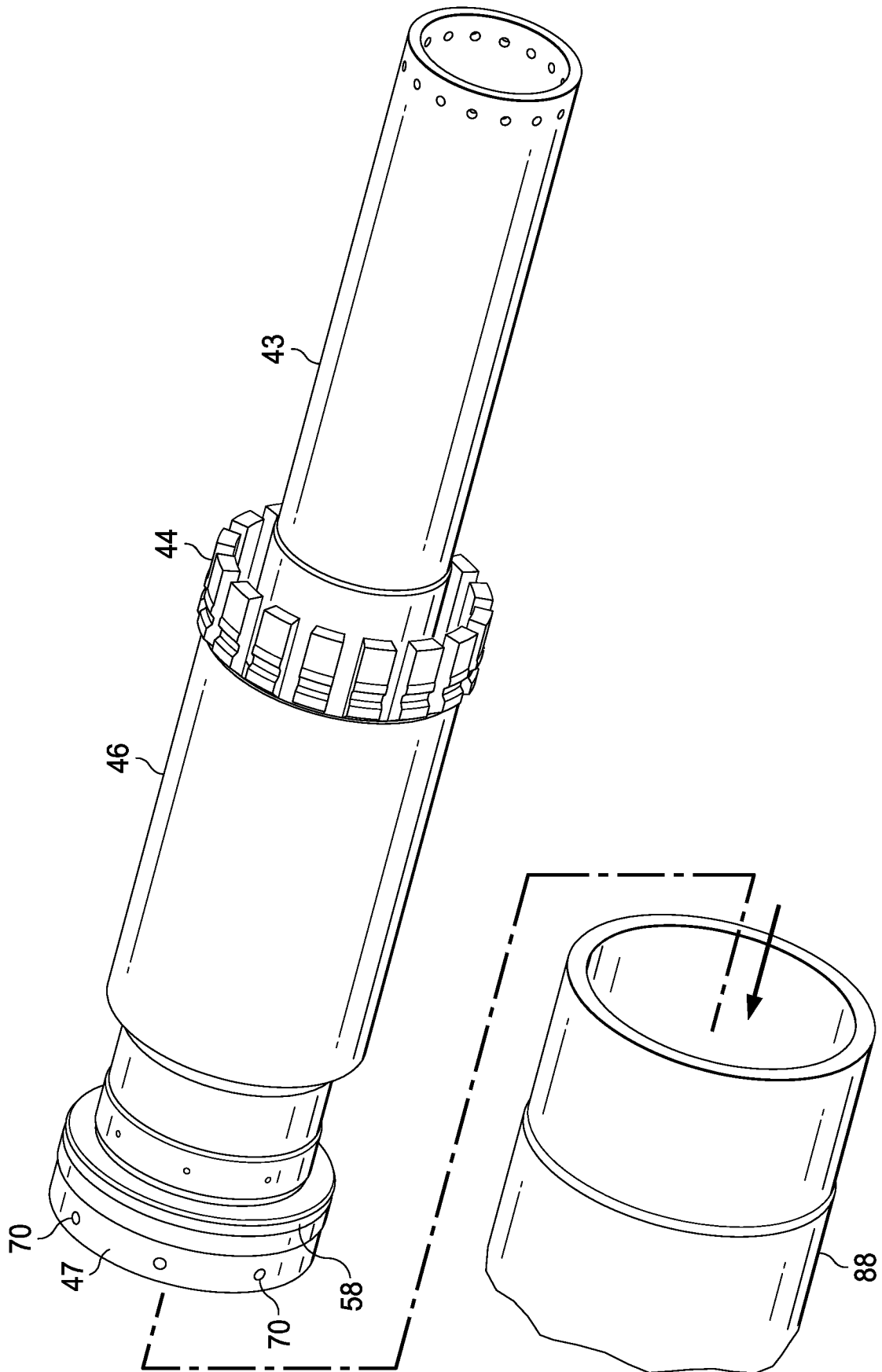

FIG. 11

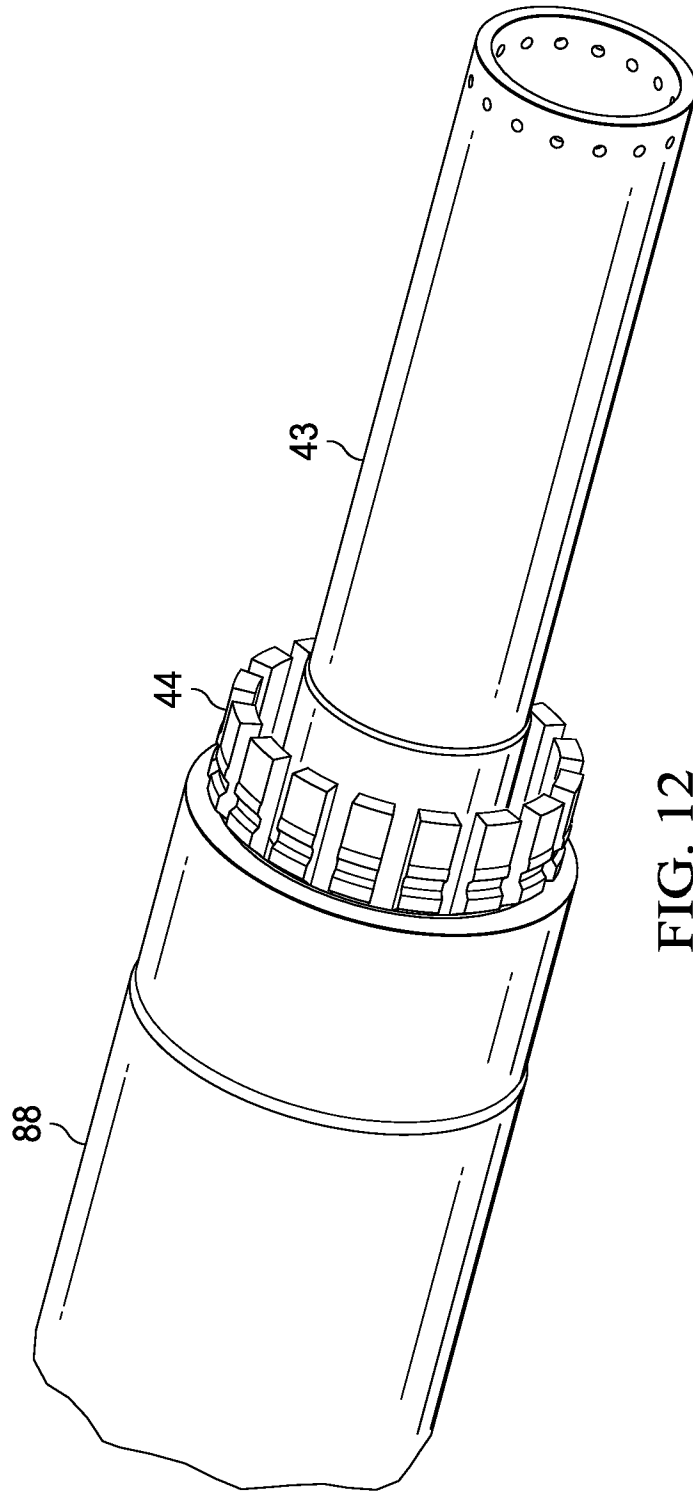

FIG. 12

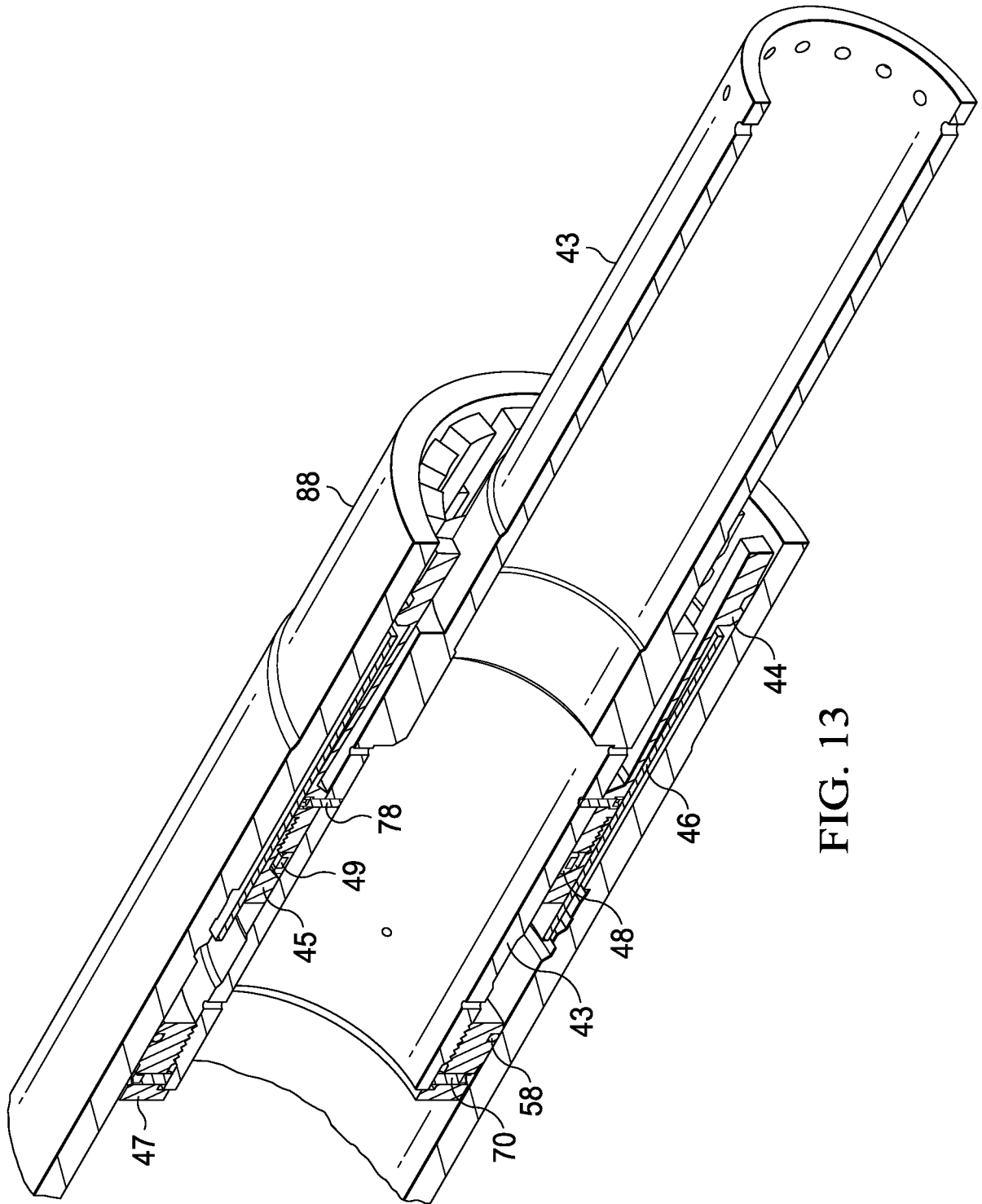

FIG. 13

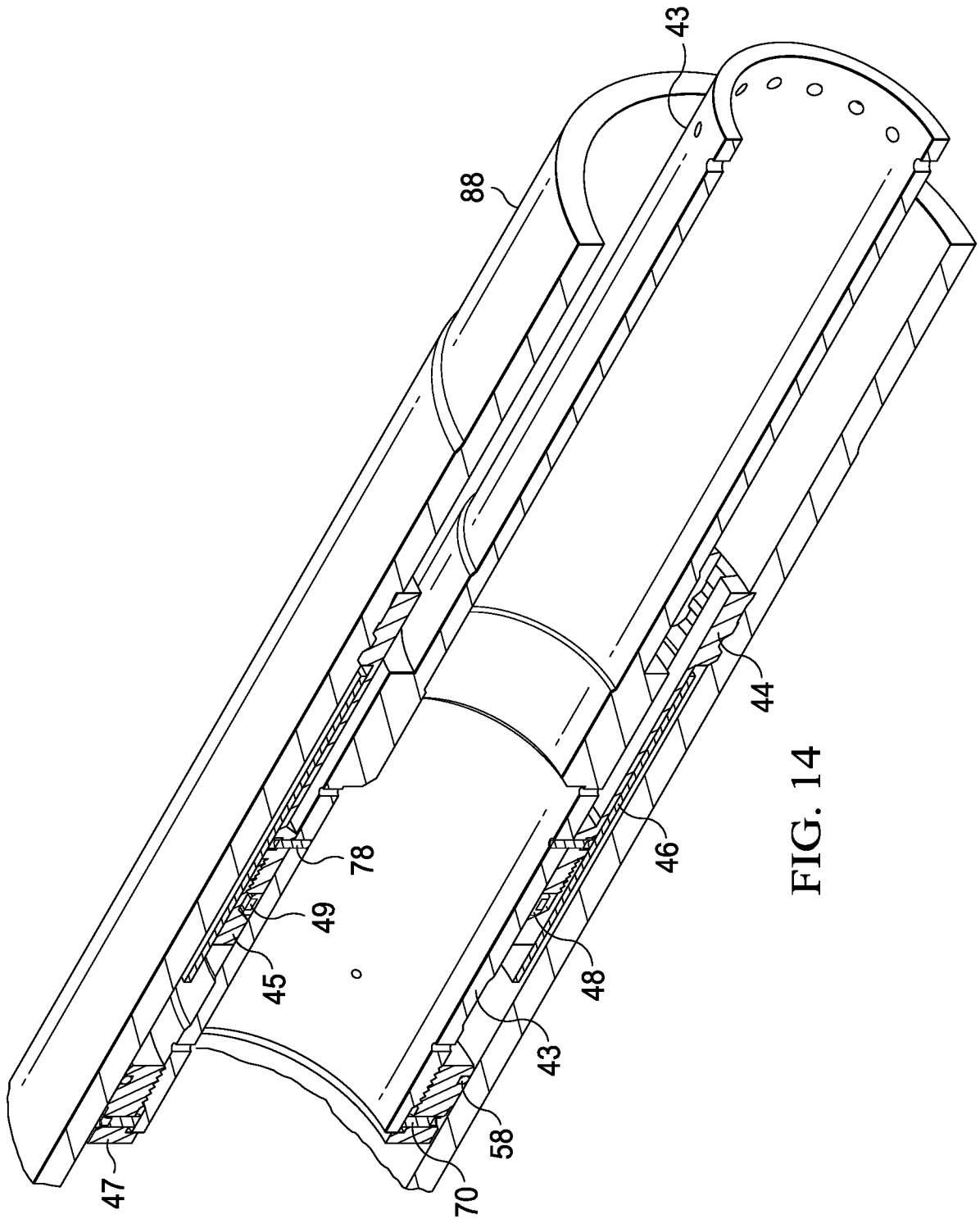

FIG. 14

16/27

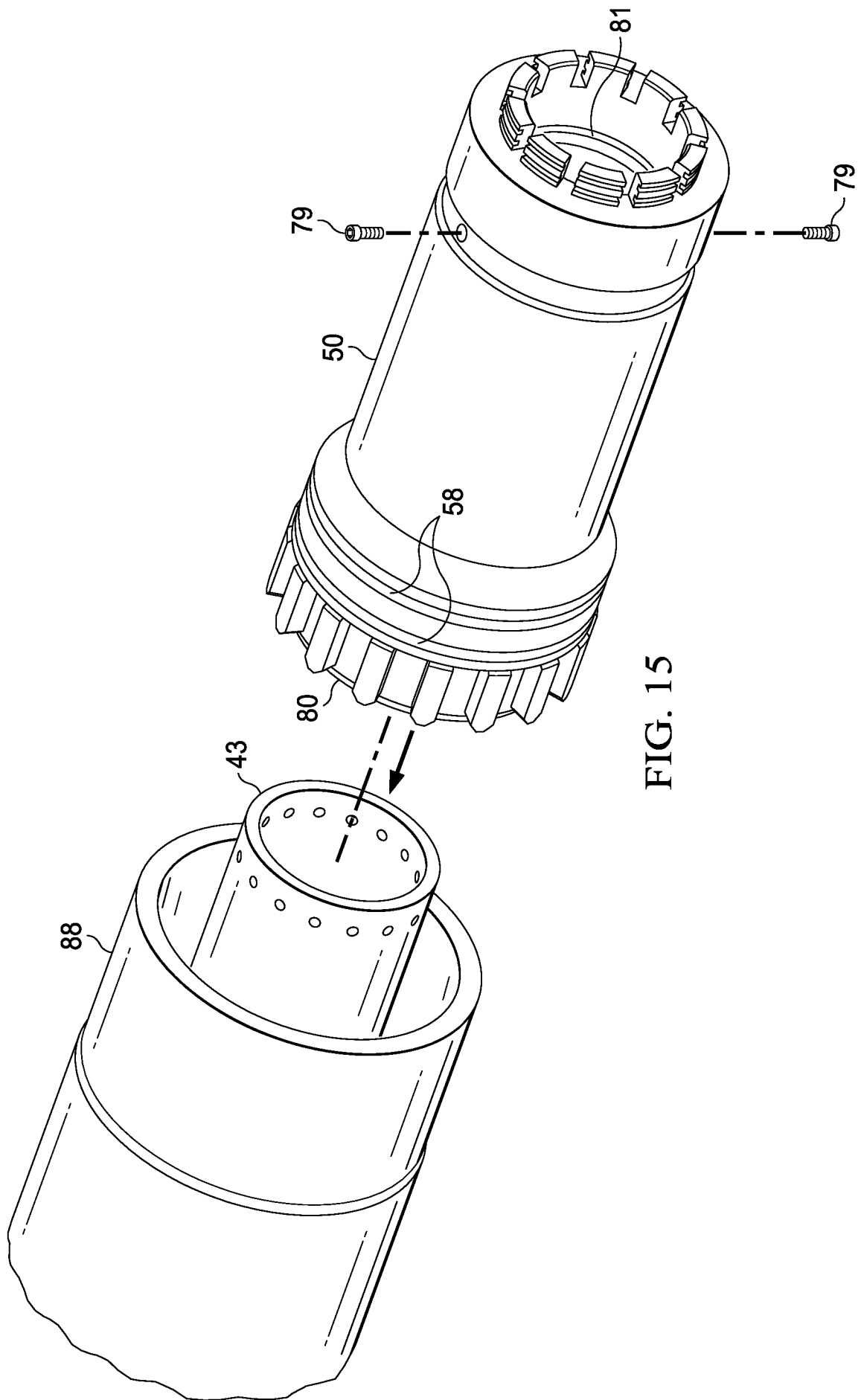

FIG. 15

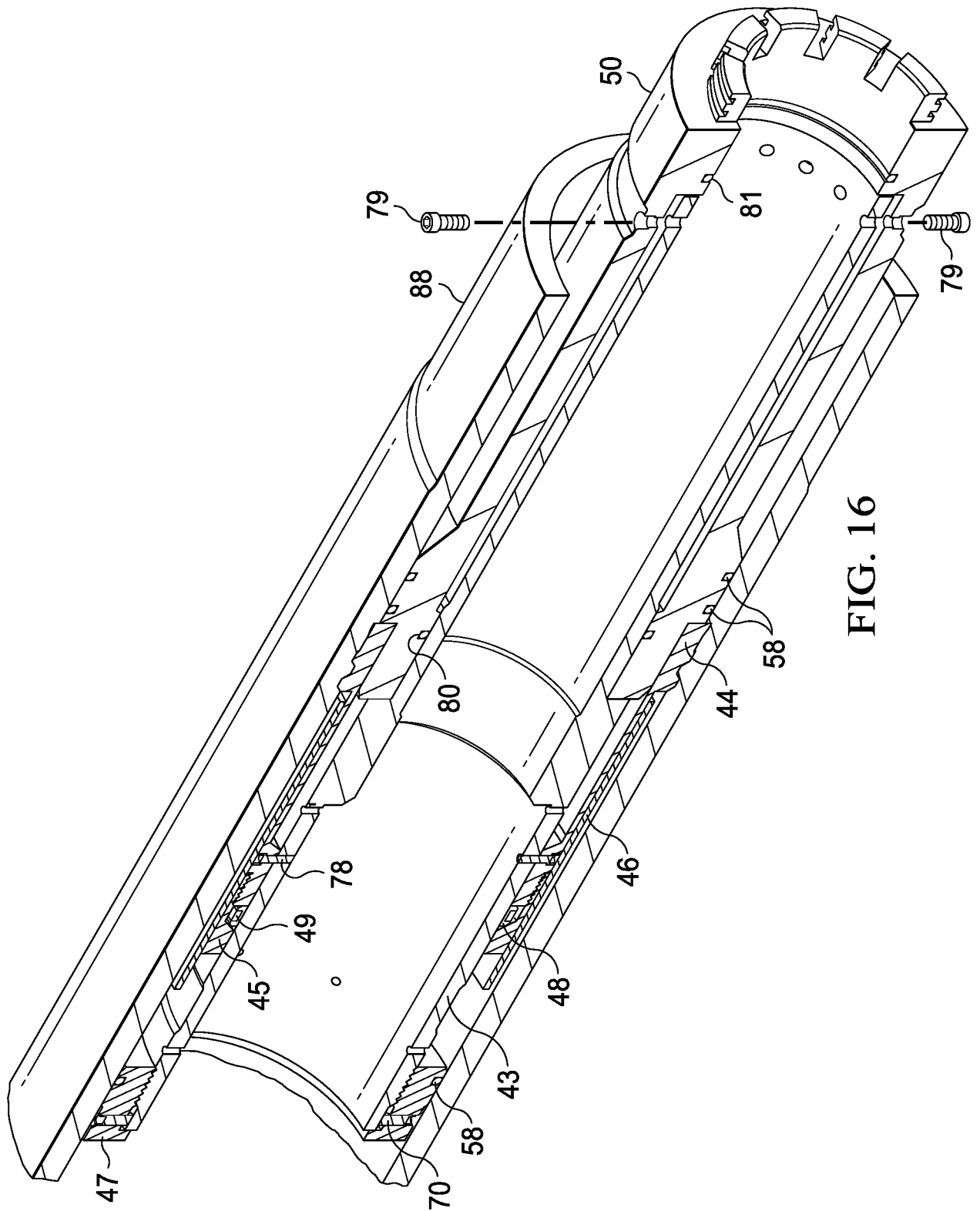

FIG. 16

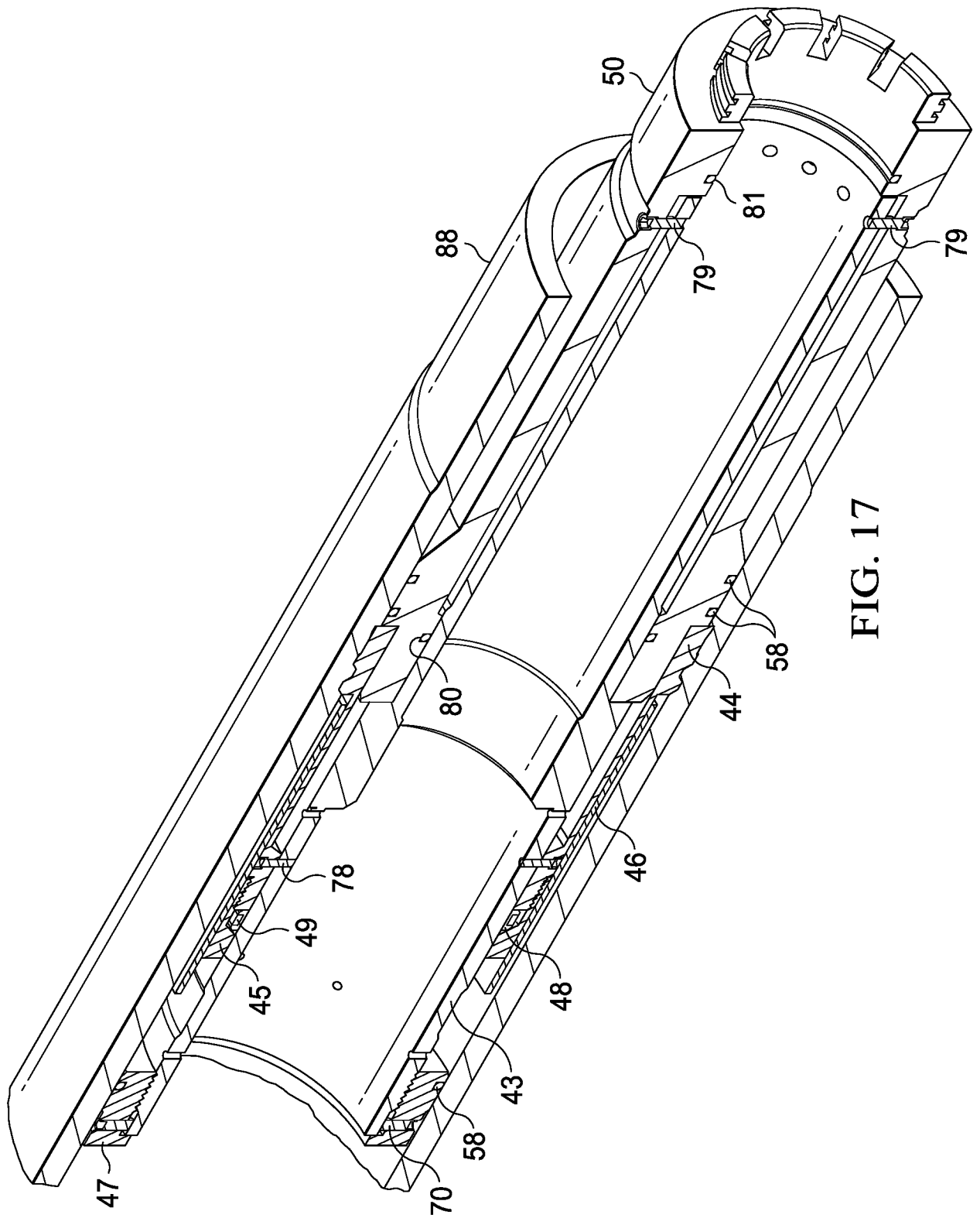
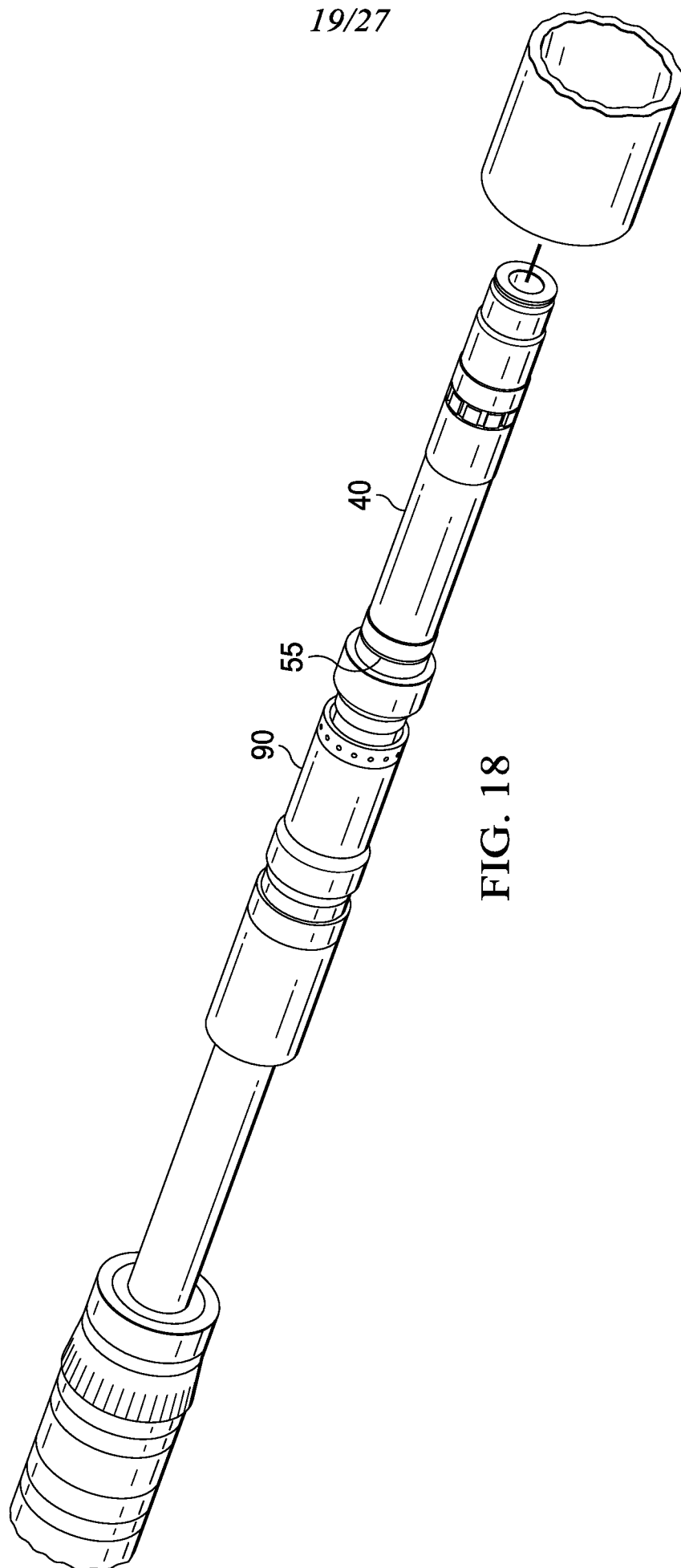

FIG. 17



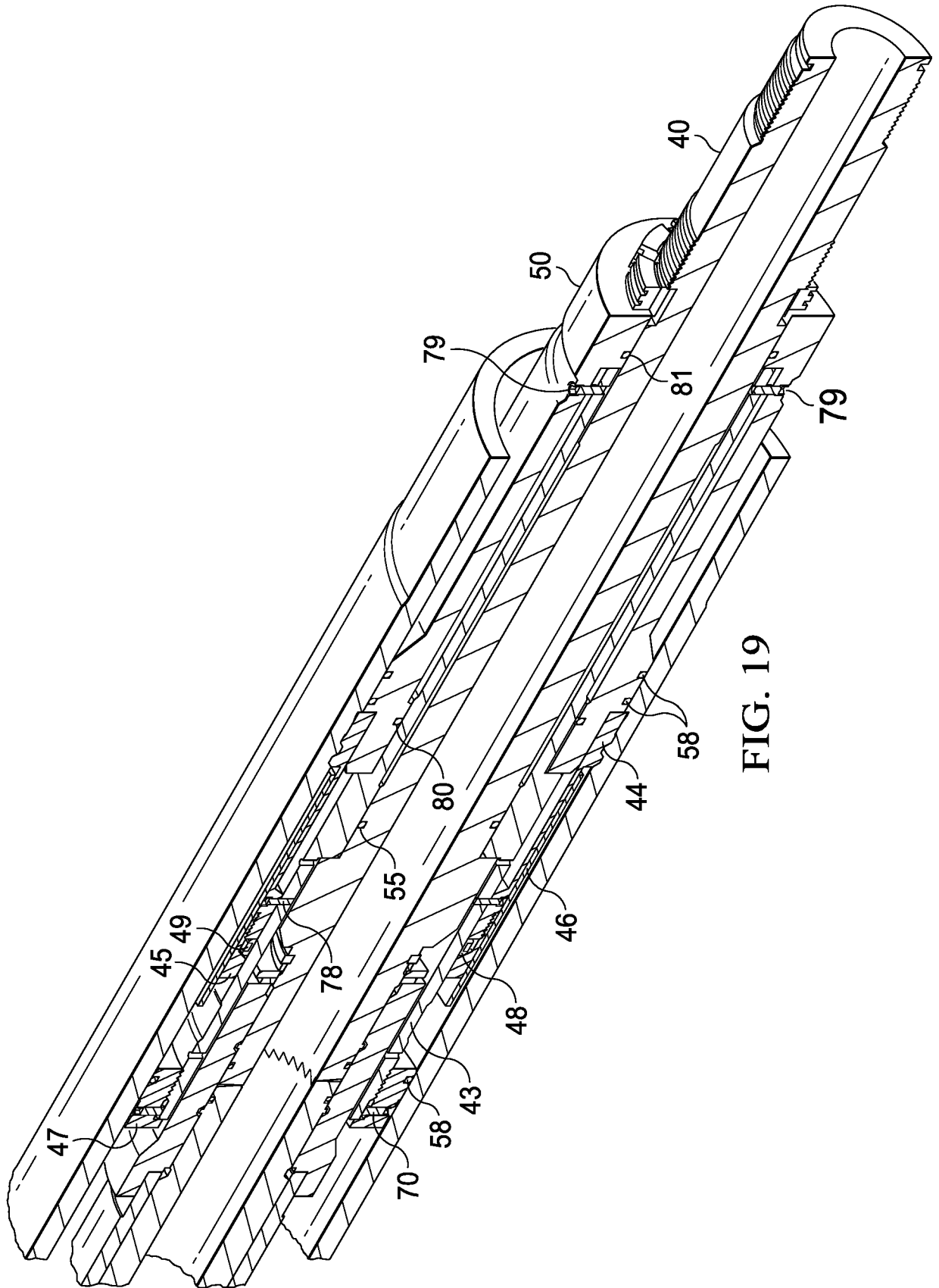
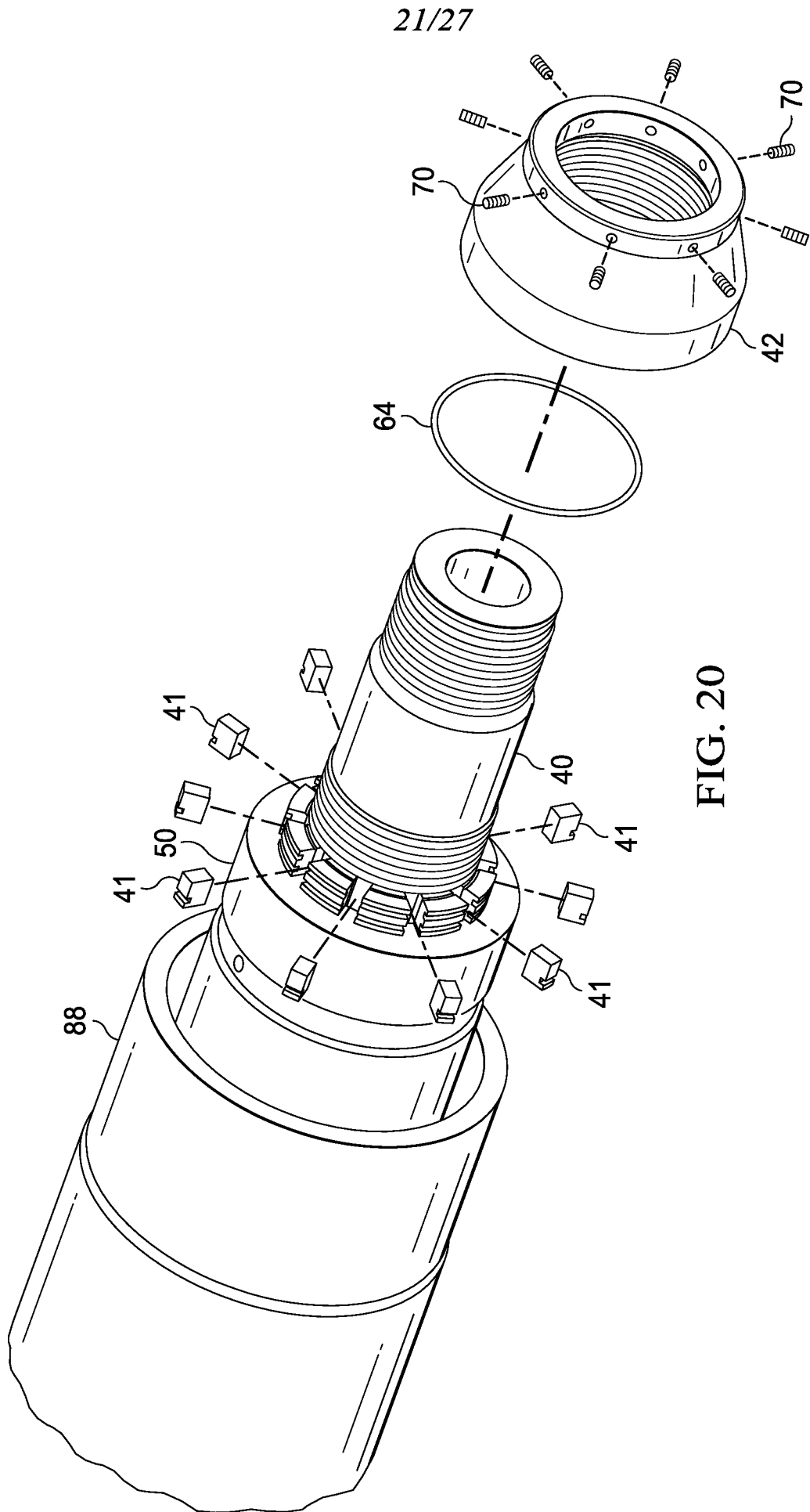

FIG. 19



22/27

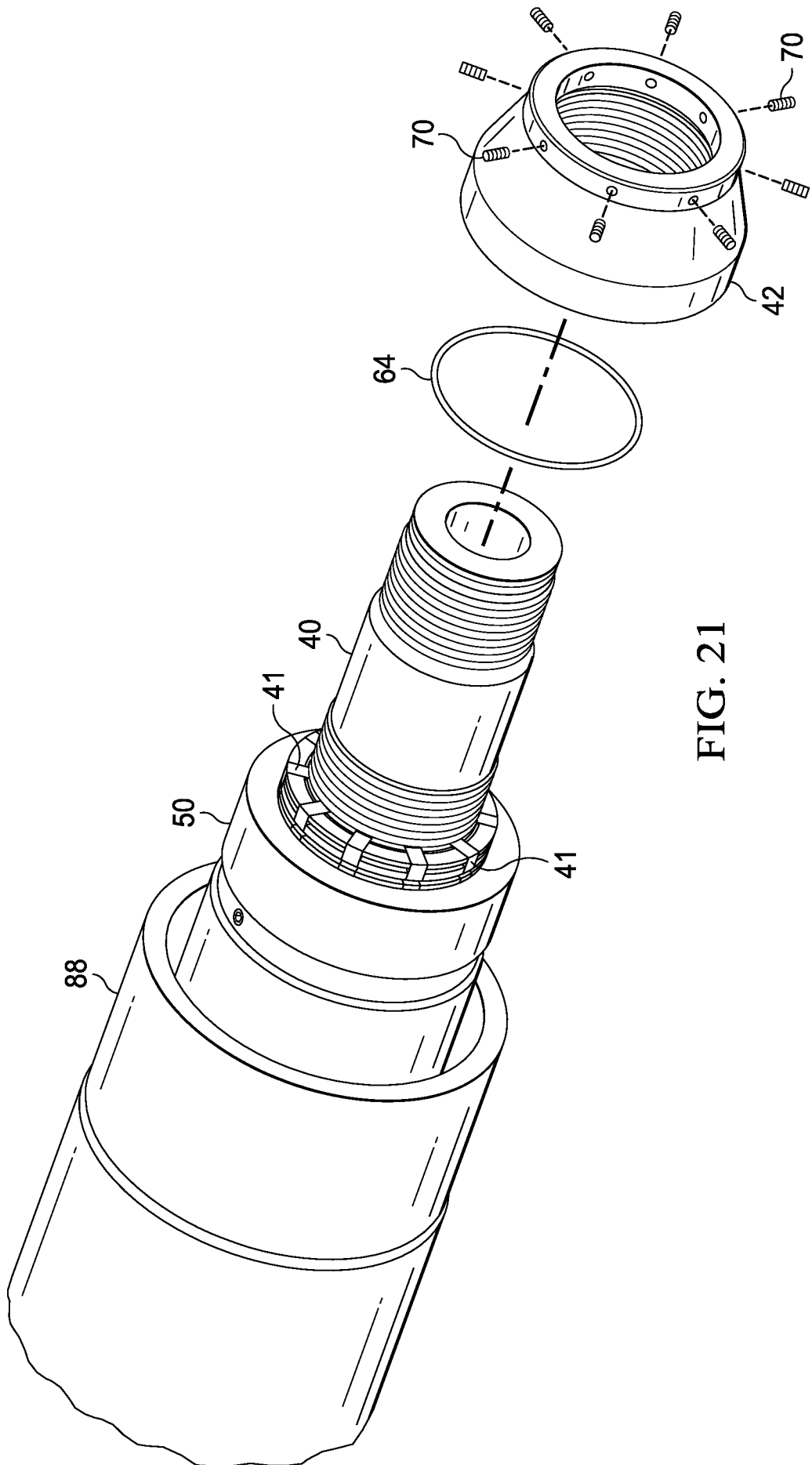

FIG. 21

23/27

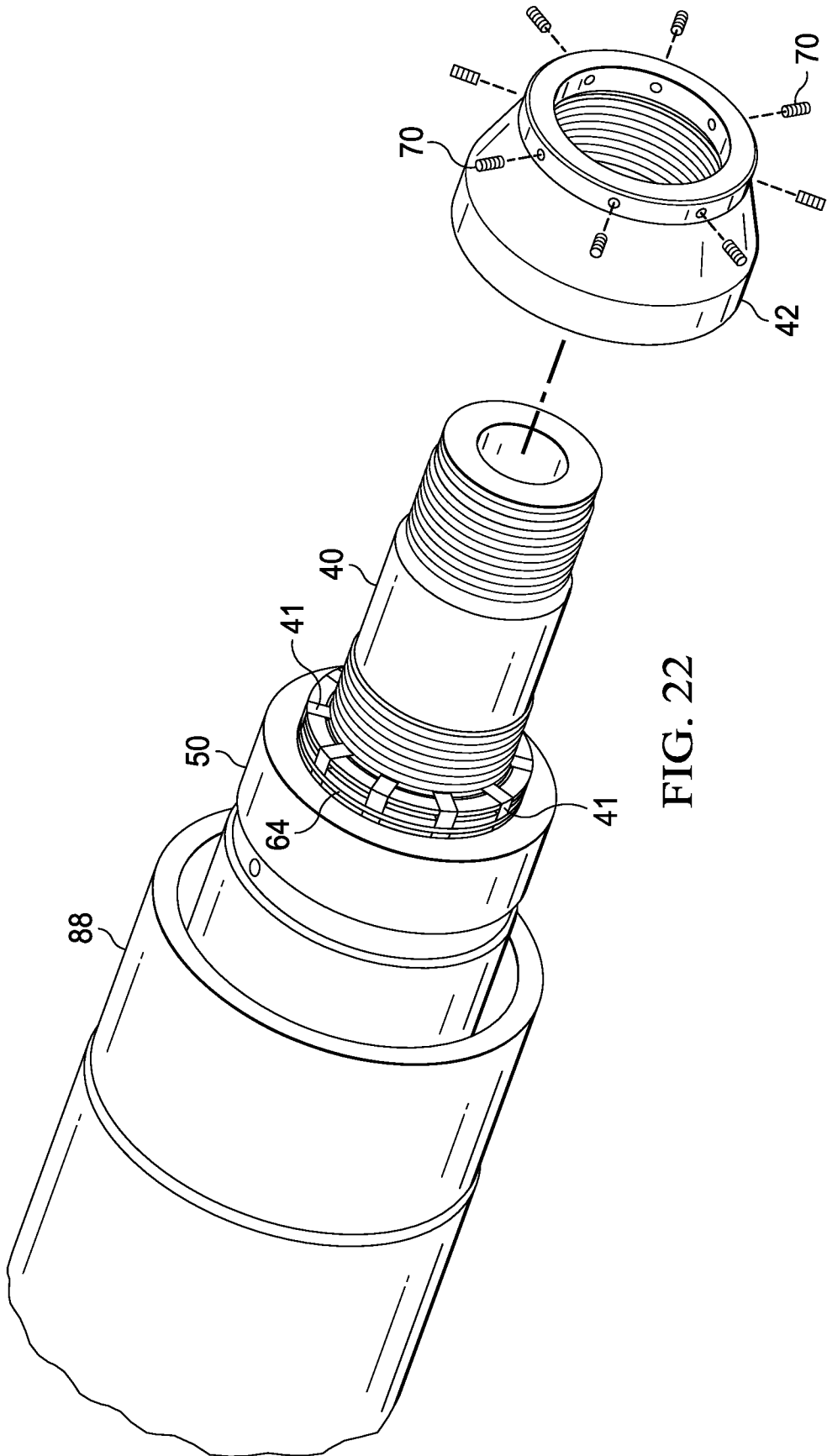

FIG. 22

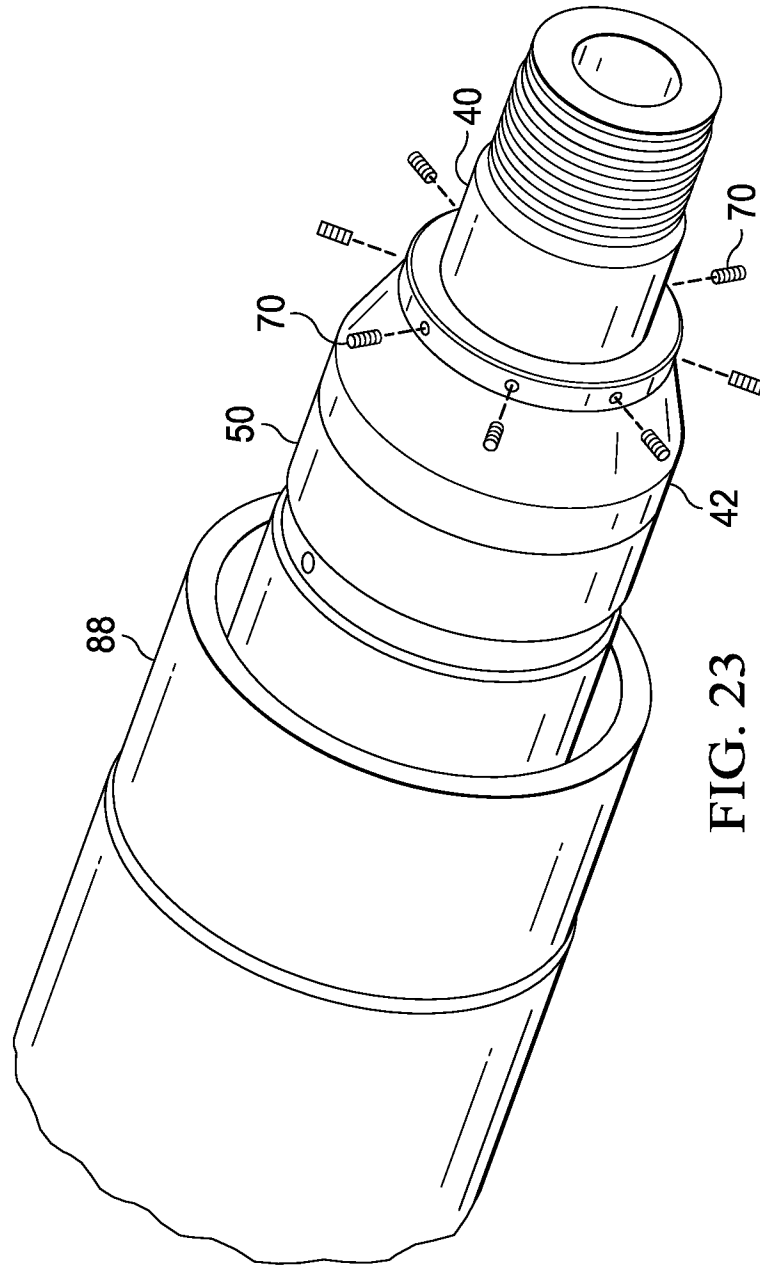

FIG. 23

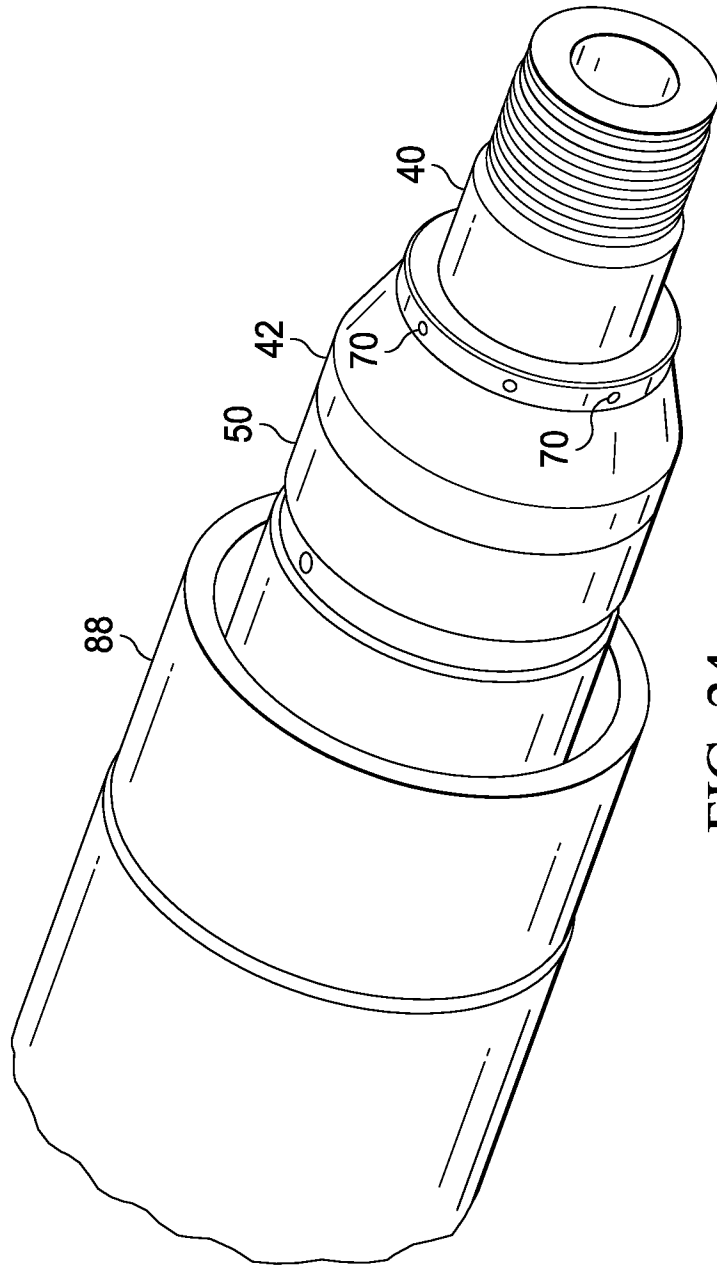

FIG. 24

26/27

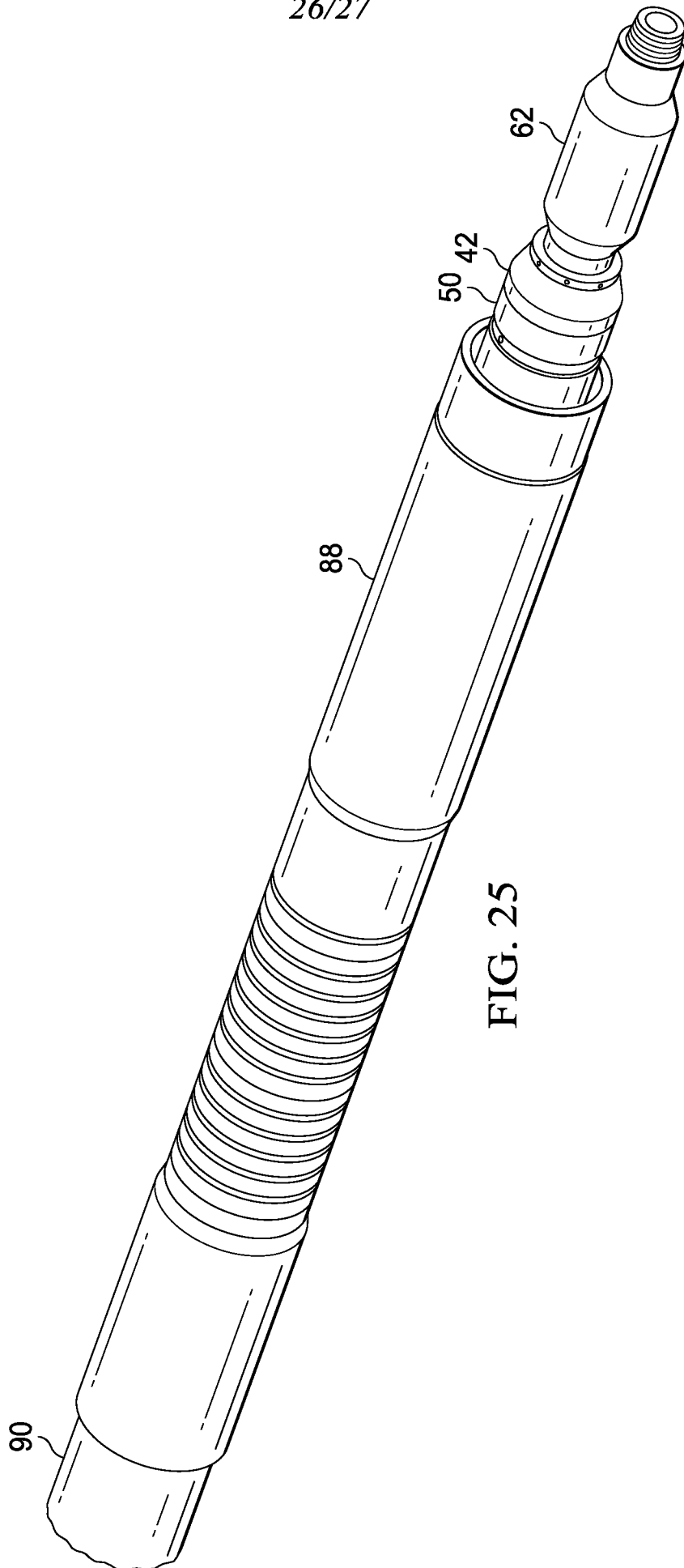

FIG. 25

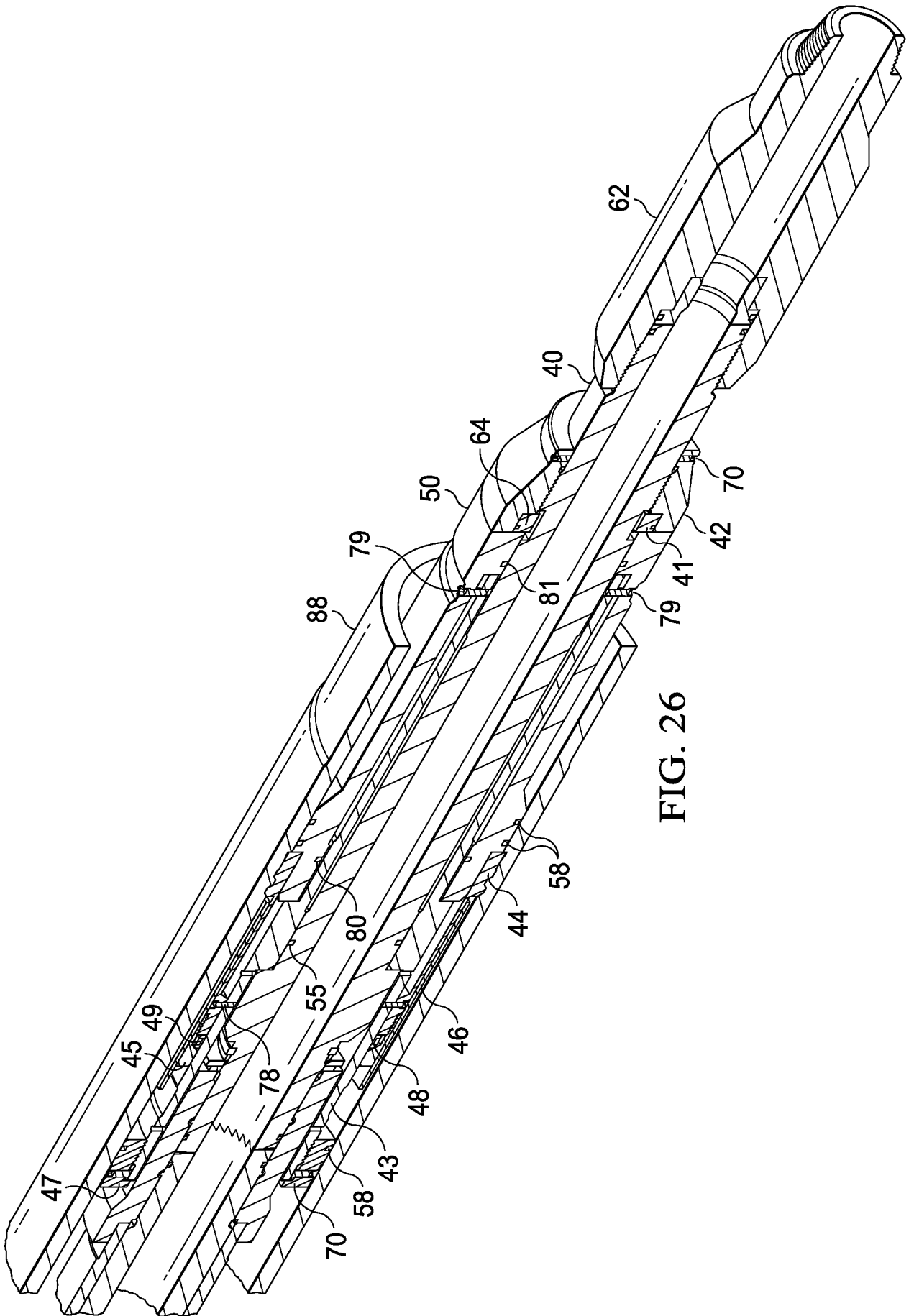

FIG. 26

A. CLASSIFICATION OF SUBJECT MATTER**E21B 17/02(2006.01)i, E21B 23/02(2006.01)i, E21B 43/10(2006.01)i**

According to International Patent Classification (IPC) or to both national classification and IPC

B. FIELDS SEARCHED

Minimum documentation searched (classification system followed by classification symbols)

E21B 17/02; E21B 33/10; E21B 23/06; E21B 33/04; E21B 19/08; E21B 23/00; E21B 23/02; E21B 43/10

Documentation searched other than minimum documentation to the extent that such documents are included in the fields searched

Korean utility models and applications for utility models

Japanese utility models and applications for utility models

Electronic data base consulted during the international search (name of data base and, where practicable, search terms used)

eKOMPASS(KIPO internal) & Keywords: coupler, liner hager, inner sub-assembly, collet prop mandrel, inserting

C. DOCUMENTS CONSIDERED TO BE RELEVANT

Category*	Citation of document, with indication, where appropriate, of the relevant passages	Relevant to claim No.
X	US 2008-0257560 A1 (BRISCO et al.) 23 October 2008 See paragraphs [0042]-[0057], [0072]-[0086]; and figures 1, 2A-2L.	1
Y		2-17
Y	US 4823881 A (STREICH, STEVEN G.) 25 April 1989 See column 7, line 1 - column 12, line 20; and figures 1, 2A-2E.	2-17
A	US 2012-0298376 A1 (TWARDOWSKI, ERIC M.) 29 November 2012 See paragraphs [0049]-[0055]; and figures 1A-1B, 2-6.	1-17
A	US 2015-0060086 A1 (HALLIBURTON ENERGY SERVICES, INC.) 05 March 2015 See paragraphs [0023]-[0031]; and figures 1, 2A-2B, 3A-3B.	1-17
A	EP 1712729 B1 (DRIL-QUIP, INC.) 20 July 2011 See paragraphs [0025]-[0033]; and figures 1A-1J.	1-17

 Further documents are listed in the continuation of Box C. See patent family annex.

* Special categories of cited documents:

"A" document defining the general state of the art which is not considered to be of particular relevance

"E" earlier application or patent but published on or after the international filing date

"L" document which may throw doubts on priority claim(s) or which is cited to establish the publication date of another citation or other special reason (as specified)

"O" document referring to an oral disclosure, use, exhibition or other means

"P" document published prior to the international filing date but later than the priority date claimed

"T" later document published after the international filing date or priority date and not in conflict with the application but cited to understand the principle or theory underlying the invention

"X" document of particular relevance; the claimed invention cannot be considered novel or cannot be considered to involve an inventive step when the document is taken alone

"Y" document of particular relevance; the claimed invention cannot be considered to involve an inventive step when the document is combined with one or more other such documents, such combination being obvious to a person skilled in the art

"&" document member of the same patent family

Date of the actual completion of the international search

20 December 2016 (20.12.2016)

Date of mailing of the international search report

21 December 2016 (21.12.2016)

Name and mailing address of the ISA/KR

International Application Division

Korean Intellectual Property Office

189 Cheongsa-ro, Seo-gu, Daejeon, 35208, Republic of Korea

Facsimile No. +82-42-481-8578

Authorized officer

KIM, Jin Ho

Telephone No. +82-42-481-8699



INTERNATIONAL SEARCH REPORT

Information on patent family members

International application No.

PCT/US2016/023812

Patent document cited in search report	Publication date	Patent family member(s)	Publication date		
US 2008-0257560 A1	23/10/2008	AU 2008-242341 A1	30/10/2008		
		AU 2008-242341 B2	01/12/2011		
		BR PI0810377 A2	29/10/2014		
		CA 2684547 A1	30/10/2008		
		CA 2684547 C	07/10/2014		
		CN 101688438 A	31/03/2010		
		CN 101688438 B	19/06/2013		
		EP 2140098 A1	06/01/2010		
		EP 2140098 A4	25/11/2015		
		MX 2009011261 A	05/11/2009		
		US 8393389 B2	12/03/2013		
		WO 2008-130876 A1	30/10/2008		
		US 4823881 A	25/04/1989	EP 0328327 A1	16/08/1989
				EP 0328327 B1	21/04/1993
US 2012-0298376 A1	29/11/2012	AU 2012-258555 A1	09/01/2014		
		CA 2837085 A1	29/11/2012		
		EP 2715045 A2	09/04/2014		
		WO 2012-162666 A2	29/11/2012		
		WO 2012-162666 A3	13/06/2013		
US 2015-0060086 A1	05/03/2015	US 2015-0060049 A1	05/03/2015		
		WO 2015-034489 A1	12/03/2015		
EP 1712729 B1	20/07/2011	AU 2002-309908 A8	03/12/2002		
		EP 1392953 B1	14/03/2007		
		EP 1712729 A2	18/10/2006		
		EP 1712729 A3	27/12/2006		
		EP 1712730 A2	18/10/2006		
		EP 1712730 A3	27/12/2006		
		EP 1712730 B1	15/12/2010		
		EP 1712731 A1	18/10/2006		
		EP 1712731 B1	02/09/2009		
		EP 1712732 A1	18/10/2006		
		EP 1712732 B1	15/07/2009		
		EP 2020482 A2	04/02/2009		
		EP 2020482 A3	27/04/2011		
		EP 2020482 B1	26/09/2012		
		GB 2381024 A	23/04/2003		
		US 6575238 B1	10/06/2003		
		US 6655456 B1	02/12/2003		
		US 6666276 B1	23/12/2003		
		US 6681860 B1	27/01/2004		
		US 6698513 B1	02/03/2004		
US 6712152 B1	30/03/2004				
US 6739398 B1	25/05/2004				
US 6761221 B1	13/07/2004				
WO 02-095178 A2	28/11/2002				

INTERNATIONAL SEARCH REPORT

Information on patent family members

International application No.

PCT/US2016/023812

Patent document cited in search report	Publication date	Patent family member(s)	Publication date
		WO 02-097234 A1	05/12/2002