

May 9, 1961

R. F. LO PRESTI

2,983,365

SUPPORTING STRUCTURE FOR FLEXIBLE STRAND SIDEFRAME CONVEYOR

Filed July 29, 1958

2 Sheets-Sheet 1

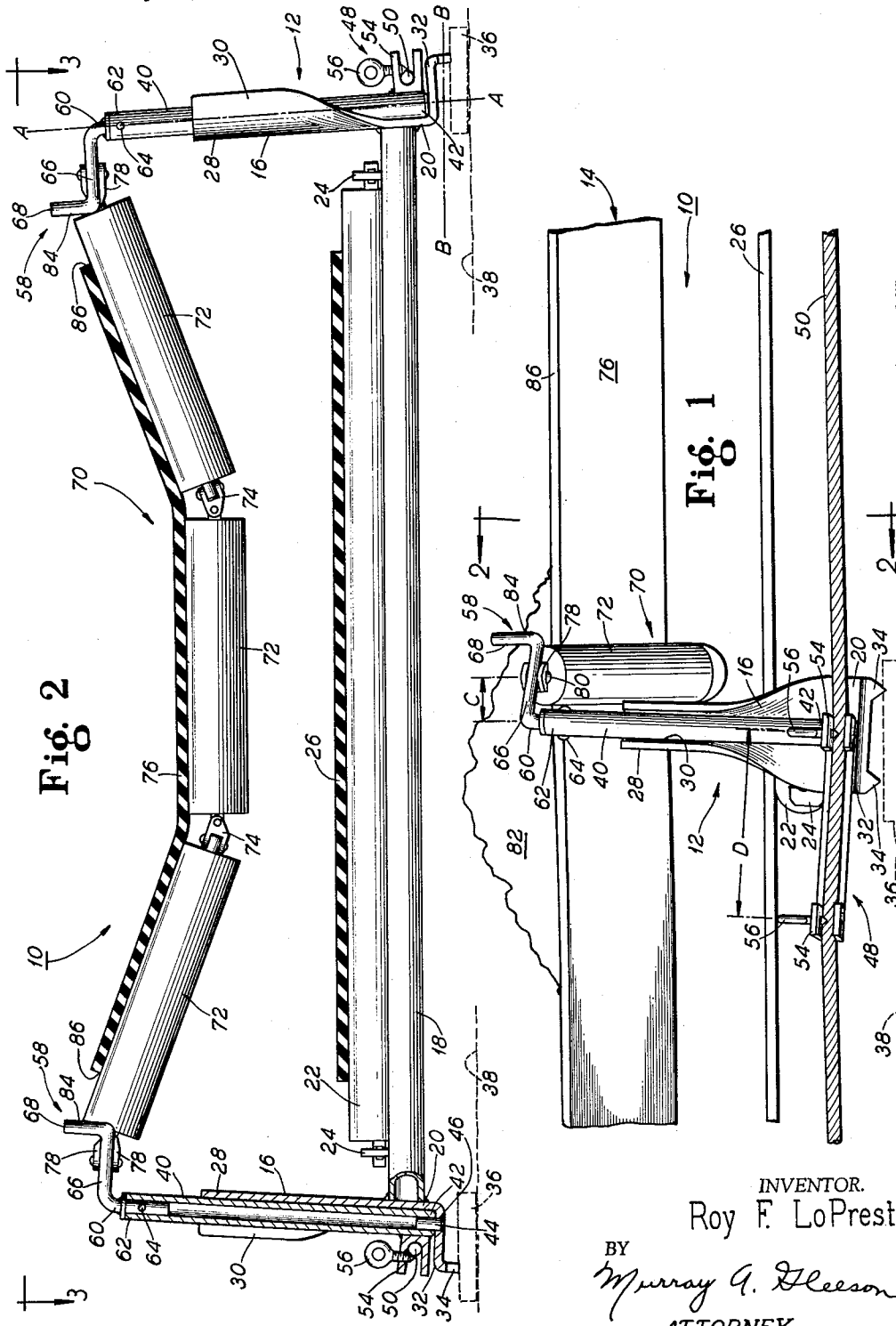

Fig. 1

Fig. 2

INVENTOR.
Roy F. LoPresti

BY
Murray G. Gleason
ATTORNEY

May 9, 1961

R. F. LO PRESTI

2,983,365

SUPPORTING STRUCTURE FOR FLEXIBLE STRAND SIDEFRAME CONVEYOR

Filed July 29, 1958

2 Sheets-Sheet 2

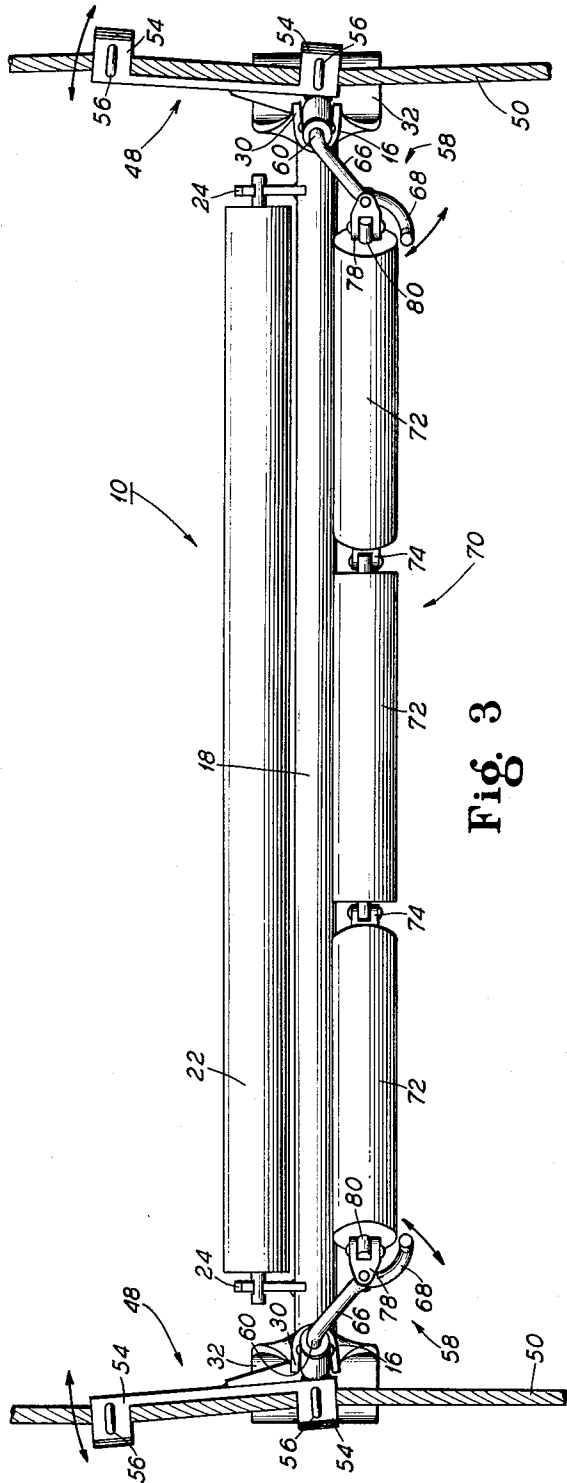

Fig. 3

INVENTOR.

Roy F. LoPresti

BY

Murray A. Gleason

ATTORNEY

1

2,983,365

SUPPORTING STRUCTURE FOR FLEXIBLE STRAND SIDEFRA

Roy F. Lo Presti, Chicago, Ill., assignor to Goodman Manufacturing Company, Chicago, Ill., a corporation of Illinois

Filed July 29, 1958, Ser. No. 751,749

11 Claims. (Cl. 198—202)

This invention relates to flexible strand sideframe conveyors and more particularly to an improved supporting structure for such conveyors.

It is the primary object of this invention to provide a flexible strand sideframe conveyor with an improved supporting structure which positions the flexible strand sideframes of such conveyor at a level that is immediately adjacent the underlying surface over which the conveyor is trained in order to decrease the overall working height of the conveyor.

It is another object of this invention to provide a supporting structure for a flexible strand sideframe conveyor which positions the strand sideframes at a level that is immediately adjacent the primary support or the surface which underlies the conveyor to enable the conveyor to be effectively separated by merely parting the conveyor belting without disturbing the supporting structure and flexible strand sideframes so that machines, material and other supplies may be easily transferred from one side of the conveyor to the other side thereof.

It is a further object of this invention to provide a supporting structure for supporting a troughing assembly and strand sideframe of a flexible strand sideframe conveyor so that deflection of the troughing assembly generally downwardly will cause the strand sideframe to be deflected generally upwardly.

It is another object of this invention to provide a supporting structure for supporting a troughing assembly and strand sideframe of a flexible strand sideframe conveyor so that the strand sideframe will be deflected generally transversely outwardly relative to the course along which the conveyor is trained in response to the generally downward deflection of the troughing assembly under the influence of a loaded condition on the conveyor belt.

In order to accomplish the above stated desired objects, the present invention provides a flexible strand sideframe conveyor with an improved generally upwardly extending supporting structure which is secured adjacent the lower end portions thereof to the strand sideframes and positions the strand sideframes immediately adjacent the underlying surface over which the conveyor is trained. The upper end portion of the supporting structure is pivotally connected to the troughing assembly which supports the conveyor belt with the troughing assembly being generally longitudinally spaced in one direction relative to the conveyor course from the supporting structure and the strand sideframes are secured at a location which is longitudinally spaced from the supporting structure in a direction that is generally opposite the one direction so that the troughing assembly will overhang the supporting structure. Further, the supporting structure is provided with pivot means which enables the supporting structure to pivot generally longitudinally relative to the conveyor course and a rotating means which enables a part of the supporting structure to rotate about a generally upwardly extending rotational axis that diverges generally upwardly-inwardly from a vertical relative to the conveyor course so that, downward deflection of the

2

troughing assembly will cause the supporting structure to pivot generally longitudinally relative to the conveyor course and also rotate the part thereof about the rotational axis so that the strand sideframes will be deflected generally upwardly and/or generally transversely outwardly relative to the conveyor course.

Other objects and important features of the invention will be apparent from a study of the specification following taken with the drawing, which together disclose and describe a preferred embodiment of the invention and what is now considered to be the best mode of practicing the principles thereof. Other embodiments may be suggested to those having the benefit of the teaching herein, and such other embodiments are intended to be reserved especially as they fall within the scope and the spirit of the sub-joined claims.

In the drawing:

Fig. 1 is a side elevational view of a portion of a loaded flexible strand sideframe conveyor showing a preferred embodiment of the present invention;

Fig. 2 is an elevational view, partly in cross section, of an unloaded flexible strand sideframe conveyor similar to that of Fig. 1 taken substantially along the line 2—2 of Fig. 1, and

Fig. 3 is a plan view of a portion of a loaded flexible strand sideframe conveyor taken substantially along the line 3—3 of Fig. 2.

Referring now to the drawing wherein there is illustrated a portion of a flexible strand sideframe conveyor 10 which includes a plurality of supporting structures 12, only one of which is illustrated, for supporting a conveyor belt 14 along a given conveyor course at longitudinally spaced intervals therealong.

Each of the supporting structures 12 includes a pair of transversely spaced generally vertically upwardly extending elongated support members 16—16 which have the longitudinal axes thereof inclined to the vertical generally upwardly-inwardly relative to the conveyor course. An elongated relatively rigid spacer means 18, such as a tie bar, extends generally transversely relative to the conveyor course and is secured, as by welding, to the lower end portion 20 of each support member 16 in order to retain the support members 16—16 in the transversely spaced relative relationship to each other along the given conveyor course.

A return idler assembly 22 is carried by the tie bar 18 through suitable bracket means 24 for supporting the return reach 26 of the conveyor belt 14.

Each of the support members 16 is specially constructed with the upper end portion 28 thereof being in the form of a U-shaped bight 30 which opens generally transversely outwardly relative to the conveyor course and the lower end portion 20 having a base or foot portion 32 which extends generally transversely outwardly relative to the conveyor course with the base portion having a plurality of downwardly extending support engaging portions 34—34, such as teeth or the like, which engage a support 36, such as a block or the like, at longitudinally spaced locations thereon which are preferably substantially equidistantly spaced longitudinally relative to the conveyor course to opposite sides of the support member 16.

It is to be noted that the support block 36 is preferably positioned in engagement with the primary support 38, such as a mine floor or other surface, which underlies the given course along which the conveyor may be trained.

An elongated tubular support rod 40 is mounted in each of the U-shaped bights 30 of the support members 16—16 for rotational movement about a generally upstanding rotational axis A—A that is substantially common with the longitudinal axis of the respective support member 16 with the rotational axes A—A each diverging from the

3

vertical generally upwardly-inwardly relative to the conveyor course.

The lower end portion 42 of each support rod 40 has a generally longitudinally extending pin 44 which engages an opening 46 in the base portion 32 of the respective support member 16 in order to retain the support rod 40 within the U-shaped bight 30 of the support member.

There is further provided an elongated securing means 48 adjacent the lower end portion 42 of each support rod 40 for securing the supporting structure 12 to a pair of generally parallel transversely spaced flexible strand sideframes 50—50 which extend along the conveyor course and which are further positioned substantially immediately adjacent the underlying surface 38 over which the conveyor 10 is trained.

Each of the securing means 48 includes a pair of U-shaped portions 54—54 which are generally longitudinally spaced and which also open substantially transversely outwardly relative to the conveyor course with each of the U-shaped portions 54 being provided with clamping means 56, in the form of eye screws or the like, for retaining and clamping the strand sideframes 50—50 against shifting movement within the respective securing means 48 generally longitudinally along the conveyor course relative to the supporting structure 12.

It is to be understood that the supporting structure 12 is maintained in the desired generally vertically upwardly extending position at the spaced interval along the conveyor course by reason of the tautness or tension which is placed in the strand sideframes 50—50.

The securing means 48 extend substantially horizontally and generally longitudinally in one direction relative to the conveyor course from the respective support rod 40 and are secured thereto, as by welding or the like, for common rotation therewith generally transversely outwardly-upwardly and inwardly-downwardly of the conveyor course about the respective rotational axis A—A, as illustrated by the arrows in Fig. 3.

A connecting means 58, in the form of a Z-shaped arm, is secured adjacent one end portion 60 thereof to the upper end portion 62 of each support rod 40 by a pin 64 with the arm 58 having common rotation with the respective support rod 40 about the axis A—A with the intermediate portion 66 and the other end portion 68 of the arm 58 moving generally transversely outwardly-upwardly and transversely inwardly-downwardly relative to the conveyor course due to the tilted or inclined disposition of the respective axis A—A.

An elongated flexible troughing assembly 70 comprising a plurality of anti-friction elements 72, such as rollers or the like, each interconnected by a universal connecting means 74, is provided for supporting a conveying reach 76 of the conveyor belt 14.

A pivotal connecting means 78 pivotally connects the intermediate portion 66 of each arm 58 to an end portion 80 of the troughing assembly 70.

The arms 58 each extend from the respective support rod 40 in another direction, generally longitudinally and substantially transversely inwardly relative to the conveyor course, that is substantially opposite to the direction in which the securing means 48 extends therefrom so that the troughing assembly 70 will overhang the supporting structure 12, note Fig. 1, and cause a tilting of the supporting structure 12, as a unit, in a substantially longitudinal direction, about a generally horizontally disposed axis B—B, relative to the conveyor course in response to a load 82 carried by the conveying reach 76 as it passes over the troughing assembly 70.

The other end portion 68 of each arm 58 defines a generally upwardly extending belt engaging portion 84 for engaging an edge 86 of the conveyor belt 14 when the conveyor belt is running in an extreme longitudinally offcenter position relative to the conveyor course.

In operation, when the load 82 passes over the troughing assembly 70 the troughing assembly will deflect gen-

4

erally downwardly to increase the troughing angle thereof and will cause the arms 58 to rotate generally transversely inwardly-downwardly and the securing means 48 to rotate generally transversely outwardly-upwardly relative to the conveyor course about the axis A—A, note the arrows in Fig. 3, and the supporting structure 12 will also tilt or cant about the axis B—B generally longitudinally of the conveyor course, as illustrated in Fig. 1, with the securing means 48 causing the strand sideframes 50—50 to be deflected generally upwardly and/or substantially transversely outwardly relative to the conveyor course. The generally downward deflection of the troughing assembly 70 and the generally upward deflection of the strand sideframes 50—50 may be definitely controlled according to the ratio of the length of the moment arms, respectively illustrated as C and D in Fig. 1, as measured generally longitudinally relative to the conveyor course. Further, it is to be noted that the troughing assemblies 70 may effectively be canted generally transversely relative to the conveyor course due to the differential rotation of the opposed support rods 40—40 in order to properly train, drive or steer the conveying reach 76 of the conveyor belt along the given conveyor course and in the event that the conveying reach 76 runs to an extreme offcenter position the belt engaging portions 84 will engage the respective edge 86 to effectively drag the troughing assembly 70 around to a training position. Also, due to the generally transversely outwardly-upwardly inclined swinging movement 30 of the arms 58 relative to the conveyor course a gravitational pull will also be imposed upon the conveying reach 76 to facilitate the training of the conveyor belt 14 along the desired course.

While the invention has been described in terms of an embodiment which it has assumed in practice, the scope of the invention should not be deemed to be limited to the precise embodiment herein shown, such other embodiments being intended to be reserved especially as they fall within the scope of the claims here appended.

I claim:

1. A supporting structure for supporting a conveyor belt of a flexible strand sideframe conveyor along a given course, said supporting structure including a generally vertically disposed substantially upstanding support member, an elongated member carried by the support member for rotational movement relative thereto about a substantially upstanding rotational axis that diverges generally upwardly-inwardly from a vertical relative to such given course, connecting means adjacent the upper end portion of the elongated member adapted to be pivotally connected to a troughing assembly for supporting such conveyor belt, and securing means adjacent the lower end portion of the elongated member adapted to be secured to strand means of such flexible strand sideframe conveyor.

2. A supporting structure for supporting a flexible strand sideframe conveyor along a given course, said supporting structure comprising an elongated generally vertically disposed substantially upstanding support member, means defining a pivot about which the upper end portion of said support member may move generally longitudinally relative to such given course, an elongated support rod carried by the support member for rotational movement relative thereto about a substantially upwardly extending rotational axis that diverges generally upwardly-inwardly from a vertical relative to such given course, connecting means carried by the upper end portion of the support rod for common rotation therewith about said rotational axis, said connecting means extending generally transversely inwardly and longitudinally in one direction from the support rod relative to such given course and adapted to be pivotally connected to a troughing assembly to support a conveyor belt of such conveyor, and elongated securing means carried by the lower end portion of the support rod for common rotation

therewith about the rotational axis, said securing means extending generally longitudinally in a direction opposite to such said one direction along the given course and adapted to be secured to a flexible strand sideframe of such conveyor.

3. In a supporting structure for a flexible strand sideframe conveyor having a flexible strand sideframe and a troughing assembly adapted to support a conveyor belt along a given course, said supporting structure including an elongated support member, means rotatably mounting said support member for rotation about a generally upstanding rotational axis that diverges upwardly-inwardly from a vertical relative to the given course, securing means for securing the lower end portion of the support member to the strand sideframe at a location generally longitudinally spaced in one direction relative to the given course from the support member, connecting means for pivotally connecting the upper end portion of the support member to the troughing assembly at another location generally longitudinally spaced from the support member in a direction substantially opposite to the one direction, said securing and connecting means being carried by the support member for common rotation therewith about the rotational axis, and means enabling said support member to pivot generally longitudinally relative to the given course, whereby said strand sideframe will be deflected generally upwardly and outwardly at the said location relative to the given course in response to a generally downward deflection of the troughing assembly at the said another location.

4. In a supporting structure for a flexible strand sideframe conveyor having a flexible strand sideframe and a troughing assembly adapted to support a conveyor belt along a given course, said supporting structure including an elongated support member, means rotatably mounting said member for rotation about a generally upstanding rotational axis that diverges upwardly-inwardly from a vertical relative to the given course, securing means for securing the lower end portion of the support member to the strand sideframe at a location generally longitudinally spaced in one direction relative to the given course from the support member, and connecting means for pivotally connecting the upper end portion of the support member to the troughing assembly at another location generally longitudinally spaced from the support member in a direction substantially opposite to the one direction, said securing and connecting means being carried by the support member for common rotation therewith about the rotational axis, whereby said strand sideframe will be deflected generally upwardly and outwardly at the said location relative to the given course in response to a generally downward deflection of the troughing assembly at the said another location.

5. In a supporting structure for a flexible strand sideframe conveyor having a flexible strand sideframe and a troughing assembly adapted to support a conveyor belt along a given course, means connecting the supporting structure to the strand sideframe and the troughing assembly, said means being rotatable about a generally upstanding rotational axis that diverges upwardly-inwardly from a vertical relative to the given course, whereby deflection of the troughing assembly generally downwardly will cause the strand sideframe to be deflected generally transversely outwardly relative to the given course.

6. A troughing idler assembly for a flexible belt conveyor especially adapted for use in low clearance operations, said troughing idler assembly including, in combination, a roller assembly comprising a plurality of rollers interconnected for flexure in a generally vertical plane to thereby enable the outer ends of the roller assembly to move toward and away from one another in response to load, and a pair of lever systems for connecting the roller assembly to a low lying flexible sideframe of the conveyor to thereby deflect the sideframe outwardly under load

whereby the yielding characteristics of the sideframe are added to the load carrying characteristics of the roller assembly, each of said lever systems including an elongated lever member having a generally horizontally oriented portion and a generally vertically oriented portion, the vertically oriented portion being slightly inclined from the vertical to thereby enable the horizontally oriented portion to swing inwardly and downwardly as said generally vertically oriented portion rotates about its axis, means for connecting the roller assembly to the generally horizontally disposed portions to thereby enable said horizontally disposed portions to swing inwardly toward one another and downwardly in response to load on the roller assembly, means for effectively connecting each of the generally vertically oriented portions of the levers to a sideframe at a location upstream, with respect to the direction of belt travel, from the connection of the roller assembly to the generally horizontally disposed portions, the connection of the sideframe to the elongated lever member being a substantial distance below the connection between the roller assembly and the generally horizontally disposed portions, and means for maintaining the generally vertically oriented portions of the lever members the same relative distance apart as they rotate about their axes.

7. The troughing idler assembly of claim 6 further characterized in that the means for effectively connecting the generally vertically oriented portion of each lever member to the flexible sideframe includes a substantially rigid arm connected to and extending upstream from said vertically oriented portion, first securing means for securing the vertically oriented portion adjacent its base to the flexible sideframe, and second securing means for securing the arm to the sideframe at an upstream point remote from the first point of securement.

8. The troughing idler assembly of claim 6 further including a pair of generally vertically axised support structures, each support structure being constructed and arranged to receive the generally vertically oriented portion of a lever member in such a manner as to enable the lever member it supports to remain in the same position relative to the other lever member as the lever members rotate about their axes.

9. The troughing idler assembly of claim 6 further characterized in that the generally horizontally oriented portions of each of the lever members terminate in upwardly extending lugs so positioned as to bear against the edge of the belt when the belt wanders off center of the troughing idler assembly.

10. A troughing idler assembly for use in a belt conveyor of the type in which a pair of flexible strands extend in generally parallel relationship along a conveying course, said troughing idler assembly including, in combination, a troughing roller assembly having a plurality of belt supporting rollers constructed and arranged to flex with respect to one another in a generally vertical plane whereby the ends of the roller assembly may move toward and away from one another, and generally upwardly extending roller assembly supporting means for supporting the troughing roller assembly and connecting it to the flexible strands, said supporting means being rotatable about generally upstanding rotational axes, one end of each supporting means being connected to said troughing roller assembly and the opposite end of each of said supporting means being connected to one of said strands to urge the flexible strands outwardly as the ends of the troughing roller assembly move inwardly towards one another.

11. A troughing idler assembly for use in a belt conveyor of the type in which a pair of flexible strands extend in generally parallel relationship along a conveying run, said troughing idler assembly including, in combination, a troughing roller assembly having a plurality of belt supporting rollers, the end portions of the troughing roller assembly being constructed and arranged to

move inwardly towards one another in response to imposition of load and outwardly away from one another in response to removal of load, and means for translating inward movement of the end portions of the troughing roller assembly towards one another into outward movement of the strands, said means including a pair of roller assembly supporting members connected to adjacent end portions of the troughing roller assembly, the supporting members being inwardly movable with the end portions as each of the supporting members swings about a generally vertically oriented pivoting axis, each of said roller assembly supporting members being connectible to an associated flexible strand on the outside of its pivoting axis as measured with respect to the length of the conveying run, whereby inward movement

of the end portions of the troughing roller assembly is translated into outward movement of the strands through the generally vertically pivoting axes of the roller assembly supporting members.

References Cited in the file of this patent

UNITED STATES PATENTS

909,833	Vrooman	Jan. 12, 1909
1,708,885	Hopkinson	Apr. 9, 1929
2,294,962	Cassell	Sept. 8, 1942
2,451,394	Klein	Oct. 12, 1948
2,896,774	Long et al.	July 28, 1959
2,922,512	Lo Presti	Jan. 26, 1960