

(12) INTERNATIONAL APPLICATION PUBLISHED UNDER THE PATENT COOPERATION TREATY (PCT)

(19) World Intellectual Property Organization
International Bureau



(43) International Publication Date
10 February 2011 (10.02.2011)

PCT

(10) International Publication Number
WO 2011/017555 A1

(51) International Patent Classification:

C10M 133/12 (2006.01) C10N 30/10 (2006.01)
C10M 141/08 (2006.01) C10N 40/04 (2006.01)

(21) International Application Number:

PCT/US2010/044601

(22) International Filing Date:

5 August 2010 (05.08.2010)

(25) Filing Language:

English

(26) Publication Language:

English

(30) Priority Data:

61/231,468 5 August 2009 (05.08.2009) US

(71) Applicant (for all designated States except US): **BASF SE** [DE/DE]; Carl-Bosch Strasse 38, 6700 Ludwigshafen, 67056 Rheinland-Pfalz (DE).

(72) Inventors; and

(75) Inventors/Applicants (for US only): **CHASAN, David, Eliezer** [US/US]; 1100 Windsor Road, Teaneck, NJ 07666 (US). **FASANO, Paul** [US/US]; 202 Weber Hill Road, Carmel, NY 10512 (US). **EGIZIACO, Margaret, Frances** [US/US]; 58 Lawrence Drive, North White Plains, NY 10603 (US). **BAJPAI, Vineet** [IN/US]; 453 E. Putnam Ave. #4g, Cos Cob, CT 06807 (US).

(74) Agents: **LAPRAIRIE, David, M.** et al.; Howard & Howard Attorneys PLLC, 450 West Fourth Street, Royal Oak, MI 48067 (US).

(81) Designated States (unless otherwise indicated, for every

kind of national protection available): AE, AG, AL, AM, AO, AT, AU, AZ, BA, BB, BG, BH, BR, BW, BY, BZ, CA, CH, CL, CN, CO, CR, CU, CZ, DE, DK, DM, DO, DZ, EC, EE, EG, ES, FI, GB, GD, GE, GH, GM, GT, HN, HR, HU, ID, IL, IN, IS, JP, KE, KG, KM, KN, KP, KR, KZ, LA, LC, LK, LR, LS, LT, LU, LY, MA, MD, ME, MG, MK, MN, MW, MX, MY, MZ, NA, NG, NI, NO, NZ, OM, PE, PG, PH, PL, PT, RO, RS, RU, SC, SD, SE, SG, SK, SL, SM, ST, SV, SY, TH, TJ, TM, TN, TR, TT, TZ, UA, UG, US, UZ, VC, VN, ZA, ZM, ZW.

(84) Designated States (unless otherwise indicated, for every

kind of regional protection available): ARIPO (BW, GH, GM, KE, LR, LS, MW, MZ, NA, SD, SL, SZ, TZ, UG, ZM, ZW), Eurasian (AM, AZ, BY, KG, KZ, MD, RU, TJ, TM), European (AL, AT, BE, BG, CH, CY, CZ, DE, DK, EE, ES, FI, FR, GB, GR, HR, HU, IE, IS, IT, LT, LU, LV, MC, MK, MT, NL, NO, PL, PT, RO, SE, SI, SK, SM, TR), OAPI (BF, BJ, CF, CG, CI, CM, GA, GN, GQ, GW, ML, MR, NE, SN, TD, TG).

Published:

- with international search report (Art. 21(3))
- with amended claims and statement (Art. 19(1))

(54) Title: LUBRICANT COMPOSITION

(57) Abstract: A lubricant composition is suitable for use in diesel engines and is resistant to degradation by oxidative by-products of biodiesel fuel. The composition includes (A) a base oil, (B) at least one diphenylamine antioxidant, and (C) at least one antioxidant. The antioxidant (C) is selected from the group consisting of a sulfur containing phenolic antioxidant, a phenyl-alpha-naphthylamine antioxidant, and combinations thereof. The lubricant composition is formed using a method. In the method, the (A) base oil has an initial oxidation value measured according to ASTM D 6186. In addition in the method, the lubricant composition has a final oxidation value measured according to ASTM D 6186 that is equal to or greater than the initial oxidation value of the (A) base oil when the lubricant composition is measured containing up to about 6 wt % of the biodiesel fuel.



WO 2011/017555 A1

LUBRICANT COMPOSITION

RELATED APPLICATIONS

[0001] This application claims priority to U.S. Prov. Ser. No. 61/231,468, filed on August 5, 2009, the disclosure of which is expressly incorporated herein by reference in its entirety.

FIELD OF THE INVENTION

[0002] The present invention generally relates to a lubricant composition including a base oil and two antioxidants. More specifically, the lubricant composition includes the base oil, at least one diphenylamine antioxidant, and at least one sulfur containing phenolic antioxidant and/or phenyl-alpha-naphthylamine antioxidant.

DESCRIPTION OF THE RELATED ART

[0003] Lubricant compositions are generally well known in the art and are broadly categorized as oil or water based compositions, i.e., compositions that include large weight percentages of non-polar compounds or large weight percentages of water. Lubricant compositions are typically further categorized as engine oils, driveline system oils, gear oils, automatic and manual transmission fluids and oils, hydraulic oils, industrial gear oils, turbine oils, rust and oxidation (R&O) inhibited oils, compressor oils, or paper machine oils, etc. Each of these compositions has particular specifications and design requirements. Nevertheless, most are designed to minimize corrosion and wear, resist thermal and physical breakdown, and be able to minimize the effects of common contaminants such as oxidizing compounds and metal fragments.

[0004] Stabilizers are typically added to lubricant compositions to improve performance characteristics. In many cases, antioxidants are utilized to reduce

oxidative degradation of the compositions and various compounds present therein. In diesel engines, for example, high temperatures in the combustion chambers of the engines and the presence of nitrogenous oxides tend to promote oxidation of the compositions. In fact, the nitrogenous oxides act as oxidation catalysts.

[0005] As is well recognized in the art, biodiesel fuel is fast becoming an important renewable energy source. Biodiesel fuel can be employed as a fuel itself (without dilution) or may be used in combination with traditional petroleum diesel fuels. The physical properties and chemical stability of biodiesel fuels depends on fatty acid composition and content. Biodiesel fuel derived from vegetable oil tends to include unsaturated alkyl groups which are more prone to oxidation than saturated alkyl groups. As a result, biodiesel fuels tend to be associated with generation and accumulation of oxidative by-products in diesel engines.

[0006] When diesel fuel is used, certain amounts of non-consumed (i.e., non-combusted) and/or oxidatively degraded fuel typically passes over piston rings and seals and enters lubricant sumps. This phenomenon is known in the art as "blow-by." Both traditional diesel fuel and biodiesel fuels are subject to this phenomenon and, as a result, tend to collect in lubricant sumps. Even though traditional diesel fuel tends to collect in the sumps, it does not usually accumulate due to evaporation. Biodiesel fuel, on the other hand, has higher distillation and boiling temperatures than traditional diesel fuel and, thus, tends to accumulate in the sumps due to reduced evaporation. In some cases, biodiesel fuel becomes concentrated in the sumps once the traditional diesel fuel evaporates. For these reasons, oxidative by-products that are produced as the result of the oxidation of the biodiesel fuels also tend to accumulate and/or become concentrated in the sumps. These oxidative by-products directly affect the performance of the lubricant compositions that flow through the

sumps. Even though many lubricant compositions include antioxidants, these antioxidants are traditionally insufficient and ineffective in neutralizing the oxidative by-products of the biodiesel fuels. As a result, performance and durability of the lubricant compositions and the diesel engines, suffer. Accordingly, there remains an opportunity to develop an improved lubricant composition that is resistant to degradation by oxidative by-products of biodiesel fuel.

BRIEF DESCRIPTION OF THE SEVERAL VIEWS OF THE DRAWINGS

[0007] Other advantages of the present invention will be readily appreciated, as the same becomes better understood by reference to the following detailed description when considered in connection with the accompanying drawings wherein:

[0008] Figure 1 is a line graph illustrating results of high pressure differential scanning calorimetry (DSC) testing of heavy duty engine oil (HDEO) according to ASTM D 6186. The HDEO includes 2 wt % aged soy methyl ester as biodiesel fuel and various weight percents of antioxidant Mixtures A-E of the Examples. Minutes of oxidation induction are plotted against a weight percent of the Mixtures added to the HDEO. The results set forth in Figure 1 demonstrate differing effectiveness of the various Mixtures relative to achieving a final oxidation value of the HDEO/biodiesel combination that is equal to or greater than an initial oxidation value of the HDEO itself, according to ASTM D 6186.

[0009] Figure 2 is similar to Figure 1 except that the HDEO is contaminated with 2 wt % aged rapeseed methyl ester as the biodiesel fuel.

[0010] Figure 3 is also similar to Figure 1 except that the HDEO is contaminated with 2 wt % aged palm methyl ester as the biodiesel fuel.

[0011] Figure 4 is also similar to Figure 1 except that the HDEO is contaminated with 2 wt % aged coconut methyl ester as the biodiesel fuel.

[0012] Figure 5 is similar to Figure 1 except that the HDEO is contaminated with 6 wt % aged soy methyl ester as the biodiesel fuel.

[0013] Figure 6 is similar to Figure 2 except that the HDEO is contaminated with 6 wt % aged rapeseed methyl ester as the biodiesel fuel.

[0014] Figure 7 is also similar to Figure 3 except that the HDEO is contaminated with 6 wt % aged palm methyl ester as the biodiesel fuel.

[0015] Figure 8 is also similar to Figure 4 except that the HDEO is contaminated with 6 wt % aged coconut methyl ester as the biodiesel fuel.

[0016] Figure 9 is a line graph illustrating results of viscosity testing of heavy duty engine oil (HDEO) according to the procedure described in SAE 040793. The HDEO includes 2 wt % aged soy methyl ester as biodiesel fuel and various weight percents of antioxidant Mixtures A-E of the Examples. Hours needed to reach a 375% increase in viscosity of the HDEO/biodiesel combination are plotted against a weight percent of the Mixtures added to the HDEO. The results set forth in Figure 9 demonstrate differing effectiveness of the various Mixtures relative to increasing a number of hours to increase viscosity according to SAE 040793.

[0017] Figure 10 is similar to Figure 9 except that the HDEO is contaminated with 2 wt % aged rapeseed methyl ester as the biodiesel fuel.

[0018] Figure 11 is also similar to Figure 9 except that the HDEO is contaminated with 2 wt % aged palm methyl ester as the biodiesel fuel.

[0019] Figure 12 is also similar to Figure 9 except that the HDEO is contaminated with 2 wt % aged coconut methyl ester as the biodiesel fuel.

[0020] Figure 13 is similar to Figure 9 except that the HDEO is contaminated with 6 wt % aged soy methyl ester as the biodiesel fuel.

[0021] Figure 14 is similar to Figure 10 except that the HDEO is contaminated with 6

wt % aged rapeseed methyl ester as the biodiesel fuel.

[0022] Figure 15 is also similar to Figure 11 except that the HDEO is contaminated with 6 wt % aged palm methyl ester as the biodiesel fuel.

[0023] Figure 16 is also similar to Figure 12 except that the HDEO is contaminated with 6 wt % aged coconut methyl ester as the biodiesel fuel.

SUMMARY OF THE INVENTION AND ADVANTAGES

[0024] The instant invention provides a lubricant composition that is suitable for use as in diesel engines and that is resistant to degradation by oxidative by-products of biodiesel fuel. The lubricant composition includes (A) a base oil, (B) at least one diphenylamine antioxidant, and (C) at least one antioxidant selected from the group consisting of a sulfur containing phenolic antioxidant, a phenyl-alpha-naphthylamine antioxidant, and combinations thereof. The invention also provides a method for improving the performance of the lubricant composition by improving resistance to degradation by oxidative by-products of the biodiesel fuel. The method includes the steps of providing the (A) base oil, providing the (B) at least one diphenylamine antioxidant, and providing the (C) at least one antioxidant. The method also includes the step of combining (A), (B), and (C) to form the lubricant composition. In the method, the (A) base oil has an initial oxidation value measured according to ASTM D 6186. In addition in the method, the lubricant composition has a final oxidation value measured according to ASTM D 6186 that is equal to or greater than the initial oxidation value of the (A) base oil when the composition is measured containing up to about 6 wt % of the biodiesel fuel. The antioxidants (B) and (C) supplement the (A) base oil and overall lubricant composition and allow the lubricant composition to resist degradation by oxidative by-products of biodiesel fuel.

DETAILED DESCRIPTION OF THE INVENTION

[0025] The present invention provides a lubricant composition that is suitable for use in diesel engines and that is resistant to degradation by oxidative by-products of biodiesel fuel. In various embodiments, the lubricant composition can be further described as a fully formulated lubricant or alternatively as an engine oil. In one embodiment, the terminology “fully formulated lubricant” refers to a total final composition that is a final commercial oil. This final commercial oil may include, for instance, detergents, dispersants, antioxidants, antifoam additives, pour point depressants, viscosity index improvers, anti-wear additives, friction modifiers, and other customary additives. In the art, engine oils may be referred to as including a base oil as described below and performance additives (not including (B) and (C) described below). The lubricant composition may be as described in U.S. Prov. Ser. No. 61/231,468, filed on August 5, 2009, the disclosure of which is also expressly incorporated herein by reference in its entirety.

[0026] The lubricant composition (hereinafter referred to as “composition”) includes (A) a base oil in addition to (B) at least one diphenylamine antioxidant, and (C) at least one antioxidant selected from the group consisting of a sulfur containing phenolic antioxidant, a phenyl-alpha-naphthylamine antioxidant, and combinations thereof. Each of (A), (B), and (C) are described in greater detail below.

Base Oil:

[0027] The base oil is not particularly limited and may be further defined as including one or more oils of lubricating viscosity such as natural and synthetic lubricating oils and mixtures thereof. In one embodiment, the base oil is further defined as a lubricant. In another embodiment, the base oil is further defined as an oil of lubricating viscosity. In still another embodiment, the base oil is further defined as a

crankcase lubricating oil for spark-ignited and compression ignited internal combustion engines, including automobile and truck engines, two-cycle engines, aviation piston engines, and marine and railroad diesel engines. Alternatively, the base oil can be further defined as an oil to be used in gas engines, stationary power engines, and turbines. The base oil may be further defined as a heavy or light duty engine oil. In one embodiment, the base oil is further defined as a heavy duty diesel engine oil. Alternatively, the base oil may be described as an oil of lubricating viscosity or lubricating oil, for instance as disclosed in U.S. Pat. Nos. 6,787,663 and U.S. 2007/0197407, each of which is expressly incorporated herein by reference. It is also contemplated that the base oil may be as described in U.S. Serial Number 61/231,468, filed on August 5, 2009, the disclosure of which is expressly incorporated herein by reference in its entirety.

[0028] The base oil may be further defined as a base stock oil. Alternatively, the base oil may be further defined as a component that is produced by a single manufacturer to the same specifications (independent of feed source or manufacturer's location) that meets the same manufacturer's specification and that is identified by a unique formula, product identification number, or both. The base oil may be manufactured or derived using a variety of different processes including but not limited to distillation, solvent refining, hydrogen processing, oligomerization, esterification, and re-refining. Re-refined stock is typically substantially free from materials introduced through manufacturing, contamination, or previous use. In one embodiment, the base oil is further defined as a base stock slate, as is known in the art.

[0029] Alternatively, the base oil may be derived from hydrocracking, hydrogenation, hydrofinishing, refined and re-refined oils or mixtures thereof or may include one or more such oils. In one embodiment, the base oil is further defined as

an oil of lubricating viscosity such as a natural or synthetic oil and/or combinations thereof. Natural oils include, but are not limited to, animal oils and vegetable oils (e.g., castor oil, lard oil) as well as liquid petroleum oils and solvent-treated or acid-treated mineral lubricating oils such as paraffinic, naphthenic or mixed paraffinic-naphthenic oils.

[0030] In various other embodiments, the base oil may be further defined as an oil derived from coal or shale. Non-limiting examples of suitable oils include hydrocarbon oils such as polymerized and interpolymerized olefins (e.g., polybutylenes, polypropylenes, propylene-isobutylene copolymers, poly(1-hexenes), poly(1-octenes), poly(1-decenes), and mixtures thereof; alkylbenzenes (e.g., dodecylbenzenes, tetradecylbenzenes, dinonylbenzenes, and di(2-ethylhexyl)-benzenes); polyphenyls (e.g., biphenyls, terphenyls, and alkylated polyphenyls), alkylated diphenyl ethers and alkylated diphenyl sulfides and the derivatives, analogs, and homologs thereof.

[0031] In still other embodiments, the base oil may be further defined as a synthetic oil which may include one or more alkylene oxide polymers and interpolymers and derivatives thereof wherein terminal hydroxyl groups are modified by esterification, etherification, or similar reactions. Typically, these synthetic oils are prepared through polymerization of ethylene oxide or propylene oxide to form polyoxyalkylene polymers which can be further reacted to form the oils. For example, alkyl and aryl ethers of these polyoxyalkylene polymers (e.g., methylpolyisopropylene glycol ether having an average molecular weight of 1,000; diphenyl ether of polyethylene glycol having a molecular weight of 500-1,000; and diethyl ether of polypropylene glycol having a molecular weight of 1,000-1,500) and/or mono- and polycarboxylic esters thereof (e.g. acetic acid esters, mixed C3 -C8 fatty acid esters, or the C13 oxo acid

diester of tetraethylene glycol) may also be utilized.

[0032] In even further embodiments, the base oil may include esters of dicarboxylic acids (e.g., phthalic acid, succinic acid, alkyl succinic acids and alkenyl succinic acids, maleic acid, azelaic acid, suberic acid, sebacic acid, fumaric acid, adipic acid, linoleic acid dimer, malonic acid, alkyl malonic acids, and alkenyl malonic acids) with a variety of alcohols (e.g., butyl alcohol, hexyl alcohol, dodecyl alcohol, 2-ethylhexyl alcohol, ethylene glycol, diethylene glycol monoether, and propylene glycol). Specific examples of these esters include, but are not limited to, dibutyl adipate, di(2-ethylhexyl sebacate, di-n-hexyl fumarate, dioctyl sebacate, diisooctyl azelate, diisodecyl azelate, dioctyl phthalate, didecyl phthalate, dieicosyl sebacate, the 2-ethylhexyl diester of linoleic acid dimer, the complex ester formed by reacting one mole of sebacic acid with two moles of tetraethylene glycol and two moles of 2-ethylhexanoic acid, and combinations thereof. Esters useful as the base oil or as included in the base oil also include those formed from C₅ to C₁₂ monocarboxylic acids and polyols and polyol ethers such as neopentyl glycol, trimethylolpropane, pentaerythritol, dipentaerythritol, and tripentaerythritol.

[0033] The base oil may be alternatively described as a refined and/or re-refined oil, or combinations thereof. Unrefined oils are typically obtained from a natural or synthetic source without further purification treatment. For example, a shale oil obtained directly from retorting operations, a petroleum oil obtained directly from distillation, or an ester oil obtained directly from an esterification process and used without further treatment, could all be utilized in this invention. Refined oils are similar to the unrefined oils except that they typically have undergone purification to improve one or more properties. Many such purification techniques are known to those of skill in the art such as solvent extraction, acid or base extraction, filtration,

percolation, and similar purification techniques. Re-refined oils are also known as reclaimed or reprocessed oils and often are additionally processed by techniques directed to removal of spent additives and oil breakdown products.

[0034] The base oil may alternatively be described as specified in the American Petroleum Institute (API) Base Oil Interchangeability Guidelines. In other words, the base oil may be further described as one or a combination of more than one of five base oil groups: Group I (sulphur content >0.03 wt %, and/or <90 wt % saturates, viscosity index 80-120); Group II (sulphur content less than or equal to 0.03 wt %, and greater than or equal to 90 wt % saturates, viscosity index 80-120); Group III (sulphur content less than or equal to 0.03 wt %, and greater than or equal to 90 wt % saturates, viscosity index less than or equal to 120); Group IV (all polyalphaolefins (PAO's)); and Group V (all others not included in Groups I, II, III, or IV). In one embodiment, the base oil is selected from the group consisting of API Group I, II, III, IV, V and combinations thereof. In another embodiment, the base oil is selected from the group consisting of API Group II, III, IV, and combinations thereof. In still another embodiment, the base oil is further defined as an API Group II, III, or IV oil and includes a maximum of about 49.9 wt %, typically up to a maximum of about 40 wt %, more typically up to a maximum of about 30 wt %, even more typically up to a maximum of about 20 wt %, even more typically up to a maximum of about 10 wt % and even more typically up to a maximum of about 5 wt % of the lubricating oil an API Group I or V oil. It is also contemplated that Group II and Group II basestocks prepared by hydrotreatment, hydrofinishing, hydroisomerization or other hydrogenative upgrading processes may be included in the API Group II described above. Moreover, the base oil may include Fisher Tropsch or gas to liquid GTL oils. These are disclosed for example in U.S. 2008/0076687, which is expressly

incorporated herein by reference.

[0035] The base oil is typically present in the composition in an amount of from 70 to 99.9, from 80 to 99.9, from 90 to 99.9, from 75 to 95, from 80 to 90, or from 85 to 95, parts by weight per 100 parts by weight of the composition. Alternatively, the base oil may be present in amounts of greater than 70, 75, 80, 85, 90, 91, 92, 93, 94, 95, 96, 97, 98, or 99, parts by weight per 100 parts by weight of the composition. In various embodiments, the amount of lubricating oil in a fully formulated lubricant (including diluent or carrier oils presents) is from about 80 to about 99.5 percent by weight, for example, from about 85 to about 96 percent by weight, for instance from about 90 to about 95 percent by weight. Of course, the weight percent of the base oil may be any value or range of values, both whole and fractional, within those ranges and values described above and/or may vary from the values and/or range of values above by $\pm 5\%$, $\pm 10\%$, $\pm 15\%$, $\pm 20\%$, $\pm 25\%$, $\pm 30\%$, etc.

(B) At Least One Diphenylamine Antioxidant:

[0036] Referring back to the (B) at least one diphenylamine antioxidant, this antioxidant is not particularly limited. In one embodiment, the diphenylamine antioxidant is further defined as having the formula:

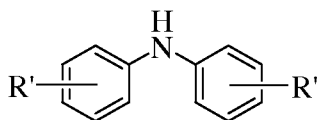

wherein each R' is independently a hydrogen atom, a straight or branched chain alkyl radical having from 1 to 18 carbon atoms, or an aralkyl radical having 7 to 14 carbon atoms. In various embodiments, the straight or branched chain alkyl radical has from 2 to 17, from 3 to 16, from 4 to 15, from 5 to 14, from 6 to 13, from 7 to 12, from 8 to 11, or from 9 to 10, carbon atoms. The alkyl group may be branched or unbranched

and may be further defined as, for example, a methyl, ethyl, propyl, isopropyl, n-butyl, sec-butyl, isobutyl, tert-butyl, 2-ethylbutyl, n-pentyl, isopentyl, 1-methylpentyl, 1,3-dimethylbutyl, n-hexyl, 1-methylhexyl, n-heptyl, isoheptyl, 1,1,3,3-tetramethylbutyl, 1-methylheptyl, 3-methylheptyl, n-octyl, 2-ethylhexyl, 1,1,3-trimethylhexyl, 1,1,3,3-tetramethylpentyl, nonyl, decyl, undecyl, 1-methylundecyl, dodecyl, 1,1,3,3,5,5-hexamethylhexyl, tridecyl, tetradecyl, pentadecyl, hexadecyl, heptadecyl, or octadecyl group. Alternatively, R' can include blends of alkyl groups that have even numbers of carbon atoms or odd numbers of carbon atoms, or both. For example, R' can include mixtures of C_x/C_y alkyl groups wherein x and y are odd numbers or even numbers. Alternatively, one may be an odd number and the other may be an even number. In various embodiments, x and y are numbers that differ from each other by two, e.g. 6 and 8, 8 and 10, 10 and 12, 12 and 14, 14 and 16, 16 and 18, 7 and 9, 9 and 11, 11 and 13, 13 and 15, or 15 and 17. R' can also include mixtures of 3 or more alkyl groups, each of which may include even or odd numbers of carbon atoms.

[0037] The aralkyl radical may be further defined as a benzyl, alpha-methyl benzyl or cumyl group. In various embodiments, the aralkyl radical has from 8 to 13, from 9 to 12, or from 10 to 11, carbon atoms. In other embodiments, the diphenylamine antioxidant is an alkylated diphenylamine, for instance a nonylated diphenylamine. Alternatively, the diphenylamine antioxidant may be, for instance, an octylated/butylated diphenylamine produced by alkylating diphenylamine with a molar excess of diisobutylene as described in U.S. Patent No. 4,824,601, which is expressly incorporated in its entirety herein by reference. In one embodiment, the (B) at least one diphenylamine antioxidant is further defined as including at least one octylated/butylated diphenylamine antioxidant and also including thiodiethylene bis[3-(3,5-di-tert-butyl-4-hydroxyphenyl)propionate]. It is also contemplated that the (B) at

least one diphenylamine antioxidant may be as described in U.S. Prov. Ser. No. 61/231,468, filed on August 5, 2009, the disclosure of which is expressly incorporated herein by reference in its entirety.

(C) Sulfur Containing Phenolic Antioxidant/Phenyl-Alpha-Naphthylamine Antioxidant:

[0038] The sulfur containing phenolic antioxidant is also not particularly limited. In one embodiment, the sulfur containing phenolic antioxidant is further defined as having the formula:

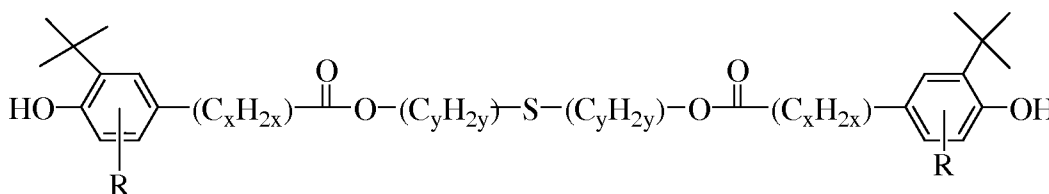

wherein x is a number from 0 to 6, y is a number from 2 to 20 and R is a straight or branched chain alkyl radical having from 1 to 6 carbon atoms. Various non-limiting examples of suitable alkyl radicals include methyl, ethyl, propyl, isopropyl, n-butyl, sec-butyl, isobutyl, tert-butyl, 2-ethylbutyl groups. In various embodiments, x is a number of from 1 to 5, from 2 to 4, or from 3 to 4. In other embodiments, y is a number of from 3 to 19, from 4 to 18, from 5 to 17, from 6 to 16, from 7 to 15, from 8 to 14, from 9 to 13, from 10 to 12, or from 11 to 12.

[0039] In one embodiment, the sulfur containing phenolic antioxidant is further defined as an ester of di(lower)alkylhydroxyphenyl alcanoic acid containing a sulfur atom as described in U.S. Patent Nos. 3,441,575 and 4,228,297, which are hereby incorporated in their entirety by reference. A specific example is thiodiethylene bis[3-(3,5-di-tert-butyl-4-hydroxyphenyl)propionate].

[0040] The phenyl-alpha-naphthylamine antioxidant is also not particularly limited. In one embodiment, the phenyl-alpha-naphthylamine antioxidant is further defined as

having the formula:

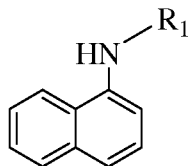

wherein R₁ is an aryl radical having from 6 to 12 carbon atoms or an aryl radical having from 6 to 20 carbon atoms and substituted by one, two or three straight or branched chain alkyl radicals each having from 1 to 18 carbon atoms. In various embodiments, aryl radical has from 7 to 11, from 8 to 10, or from 9 to 10, carbon atoms. Suitable non-limiting examples include phenyl, naphthyl or biphenyl groups. Alternatively, the aryl radical may have from 7 to 19, from 8 to 18, from 9 to 17, from 10 to 16, from 11 to 15, from 12 to 14, or from 12 to 13, carbon atoms. The one, two, or three straight or branched chain alkyl radicals can be as described above relative to R'. Alkylated phenyl-alpha-naphthylamine antioxidants are described as starting materials in U.S. Pat. No. 5,160,647, incorporated by reference. A particular example is octylated phenyl-alpha-naphthylamine. It is also contemplated that the phenyl-alpha-naphthylamine antioxidant and/or sulfur containing phenolic antioxidant may be as described in U.S. Prov. Ser. No. 61/231,468, filed on August 5, 2009, the disclosure of which is expressly incorporated herein by reference in its entirety.

[0041] In one embodiment, the (B) at least one diphenylamine antioxidant is further defined as having the aforementioned formula wherein each R' is independently a hydrogen atom, a straight or branched chain alkyl radical having from 1 to 18 carbon atoms, or an aralkyl radical having 7 to 14 carbon atoms. In this same embodiment, the (C) at least one antioxidant includes the sulfur containing phenolic antioxidant and the sulfur containing phenolic antioxidant is further defined as having the

aforementioned formula wherein x is a number from 0 to 6, y is a number from 2 to 20 and R is a straight or branched chain alkyl radical having from 1 to 6 carbon atoms.

[0042] In an alternative embodiment, the (B) at least one diphenylamine antioxidant is further defined as having the aforementioned formula wherein each R' is independently a hydrogen atom, a straight or branched chain alkyl radical having from 1 to 18 carbon atoms, or an aralkyl radical having 7 to 14 carbon atoms. In this embodiment, the (C) at least one antioxidant includes the phenyl-alpha-naphthylamine antioxidant and the phenyl-alpha-naphthylamine antioxidant is further defined as having the aforementioned formula wherein R1 is an aryl radical having from 6 to 12 carbon atoms or an aryl radical having from 6 to 20 carbon atoms and substituted by one, two or three straight or branched chain alkyl radicals each having from 1 to 18 carbon atoms.

[0043] In still another embodiment, the (B) at least one diphenylamine antioxidant is further defined as including at least one octylated/butylated diphenylamine antioxidant. In this same embodiment, the (C) at least one antioxidant includes the phenyl-alpha-naphthylamine antioxidant, and the phenyl-alpha-naphthylamine antioxidant is further defined as octylated phenyl-alpha-naphthylamine.

[0044] In various embodiments, the (B) at least one diphenylamine antioxidant and the (C) at least one antioxidant are present in a weight ratio of from about 9:1 to about 1:9, respectively. Alternatively, (B) and (C) may be present in weight ratios of about (8:1, 7:1, 6:1, 5:1, 4:1, 3:1, 2:1, or 1:1) to about (1:8, 1:7, 1:6, 1:5, 1:4, 1:3, 1:2, or 1:1). In other embodiments, the weight ratio is from about 8:2 to about 2:8, from about 7:3 to about 3:7, from about 6:4 to about 4:6 or about 1:1. The ratios described above are not limiting and may be any value or range of values, both whole and

fractional, within those ranges and values described above and/or may vary from the values and/or range of values above by $\pm 5\%$, $\pm 10\%$, $\pm 15\%$, $\pm 20\%$, $\pm 25\%$, $\pm 30\%$, etc.

[0045] In still other embodiments, the combination of (B) and (C) is present in amounts of from about 0.3 to about 7 parts by weight, of from about 0.9 to about 3.5 parts by weight, of from about 0.5 to 2, of from about 0.5 to 3, or less than about 2.1, parts by weight, per 100 parts by weight of the composition. In other embodiments, the combination of (B) and (C) is present in amounts of about 0.3, 0.5, 1, 1.5, 2, 2.5, 3, 3.5, 4, 4.5, 5, 5.5, 6, 6.5 or about 7 weight percent, based on a total weight of the composition and not the combination of biodiesel fuel and the composition. The amounts described above are not limiting and may be any value or range of values, both whole and fractional, within those ranges and values described above and/or may vary from the values and/or range of values above by $\pm 5\%$, $\pm 10\%$, $\pm 15\%$, $\pm 20\%$, $\pm 25\%$, $\pm 30\%$, etc.

[0046] In one embodiment, the (C) at least one antioxidant includes both the sulfur containing phenolic antioxidant and the phenyl-alpha-naphthylamine antioxidant. In another embodiment, the (C) at least one antioxidant includes the sulfur containing phenolic antioxidant. In still another embodiment, the (C) at least one antioxidant consists essentially of the sulfur containing phenolic antioxidant. In still a further embodiment, the (C) at least one antioxidant is free of the phenyl-alpha-naphthylamine antioxidant. Alternatively, the (C) at least one antioxidant can include the phenyl-alpha-naphthylamine antioxidant. The (C) at least one antioxidant may consist essentially of the phenyl-alpha-naphthylamine antioxidant. The (C) at least one antioxidant may also be free of the sulfur containing phenolic antioxidant.

Additives:

[0047] The composition can additionally include one or more additives to improve various chemical and/or physical properties. Non-limiting examples of the one or more additives include anti-wear additives, metal passivators, rust inhibitors, viscosity index improvers, pour point depressors, dispersants, detergents, and antifriction additives. Such composition is commonly referred to as an engine oil.

Anti-Wear Additive:

[0048] The anti-wear additive first introduced above is not particularly limited and may be any known in the art. In one embodiment, the anti-wear additive is selected from the group of ZDDP, zinc dialkyl-dithio phosphates, and combinations thereof. Alternatively, the anti-wear additive may include sulfur- and/or phosphorus- and/or halogen-containing compounds, e.g. sulfurised olefins and vegetable oils, zinc dialkyldithiophosphates, alkylated triphenyl phosphates, tritolyl phosphate, tricresyl phosphate, chlorinated paraffins, alkyl and aryl di- and trisulfides, amine salts of mono- and dialkyl phosphates, amine salts of methylphosphonic acid, diethanolaminomethyltolyltriazole, bis(2-ethylhexyl)aminomethyltolyltriazole, derivatives of 2,5-dimercapto-1,3,4-thiadiazole, ethyl 3-[(diisopropoxyphosphinothioyl)thio]propionate, triphenyl thiophosphate (triphenylphosphorothioate), tris(alkylphenyl) phosphorothioate and mixtures thereof (for example tris(isononylphenyl) phosphorothioate), diphenyl monononylphenyl phosphorothioate, isobutylphenyl diphenyl phosphorothioate, the dodecylamine salt of 3-hydroxy-1,3-thiaphosphetane 3-oxide, trithiophosphoric acid 5,5,5-tris[isooctyl 2-acetate], derivatives of 2-mercaptobenzothiazole such as 1-[N,N-bis (2-ethylhexyl)aminomethyl]-2-mercapto-1H-1,3-benzothiazole, ethoxycarbonyl-5-octyldithio carbamate, and/or combinations thereof. It is also contemplated that the

anti-wear additive may be as described in U.S. Prov. Ser. No. 61/231,468, filed on August 5, 2009, the disclosure of which is expressly incorporated herein by reference in its entirety.

[0049] The anti-wear additive is typically present in the composition in an amount of from 0.1 to 20, from 0.5 to 15, from 1 to 10, from 5 to 10, from 5 to 15, from 5 to 20, from 0.1 to 1, from 0.1 to 0.5, or from 0.1 to 1.5, parts by weight per 100 parts by weight of the composition. Alternatively, the anti-wear additive may be present in amounts of less than 20, less than 15, less than 10, less than 5, less than 1, less than 0.5, or less than 0.1, parts by weight per 100 parts by weight of the composition. Of course, the weight percent of the anti-wear additive may be any value or range of values, both whole and fractional, within those ranges and values described above and/or may vary from the values and/or range of values above by $\pm 5\%$, $\pm 10\%$, $\pm 15\%$, $\pm 20\%$, $\pm 25\%$, $\pm 30\%$, etc.

Antioxidants:

[0050] In addition to the antioxidants described above, the composition may include other antioxidants as well. Suitable, non-limiting, antioxidants include alkylated monophenols, for example 2,6-di-tert-butyl-4-methylphenol, 2-tert-butyl-4,6-dimethylphenol, 2,6-di-tert-butyl-4-ethylphenol, 2,6-di-tert-butyl-4-n-butylphenol, 2,6-di-tert-butyl-4-isobutylphenol, 2,6-dicyclopentyl-4-methylphenol, 2-(α -methylcyclohexyl)-4,6-dimethylphenol, 2,6-dioctadecyl-4-methylphenol, 2,4,6-tricyclohexylphenol, 2,6-di-tert-butyl-4-methoxymethylphenol, 2,6-di-nonyl-4-methylphenol, 2,4-dimethyl-6-(1'-methylundec-1'-yl)phenol, 2,4-dimethyl-6-(1'-methylheptadec-1'-yl)phenol, 2,4-dimethyl-6-(1'-methyltridec-1'-yl)phenol, and combinations thereof.

[0051] Other non-limiting examples of suitable antioxidants includes

alkylthiomethylphenols, for example 2,4-dioctylthiomethyl-6-tert-butylphenol, 2,4-dioctylthiomethyl-6-methylphenol, 2,4-dioctylthiomethyl-6-ethylphenol, 2,6-didodecylthiomethyl-4-nonylphenol, and combinations thereof. Hydroquinones and alkylated hydroquinones, for example 2,6-di-tert-butyl-4-methoxyphenol, 2,5-di-tert-butylhydroquinone, 2,5-di-tert-amylhydroquinone, 2,6-diphenyl-4-octadecyloxyphenol, 2,6-di-tert-butylhydroquinone, 2,5-di-tert-butyl-4-hydroxyanisole, 3,5-di-tert-butyl-4-hydroxyanisole, 3,5-di-tert-butyl-4-hydroxyphenyl stearate, bis-(3,5-di-tert-butyl-4-hydroxyphenyl) adipate, and combinations thereof, may also be utilized.

[0052] Furthermore, hydroxylated thiodiphenyl ethers, for example 2,2'-thiobis(6-tert-butyl-4-methylphenol), 2,2'-thiobis(4-octylphenol), 4,4'-thiobis(6-tert-butyl-3-methylphenol), 4,4'-thiobis(6-tert-butyl-2-methylphenol), 4,4'-thiobis-(3,6-di-sec-amylphenol), 4,4'-bis-(2,6-dimethyl-4-hydroxyphenyl) disulfide, and combinations thereof, may also be used.

[0053] It is also contemplated that alkylidenebisphenols, for example 2,2'-methylenebis(6-tert-butyl-4-methylphenol), 2,2'-methylenebis(6-tert-butyl-4-ethylphenol), 2,2'-methylenebis[4-methyl-6-(α -methylcyclohexyl)phenol], 2,2'-methylenebis(4-methyl-6-cyclohexylphenol), 2,2'-methylenebis(6-nonyl-4-methylphenol), 2,2'-methylenebis(4,6-di-tert-butylphenol), 2,2'-ethylidenebis (4,6-di-tert-butylphenol), 2,2'-ethylidenebis(6-tert-butyl-4-isobutylphenol), 2,2'-methylenebis [6-(α -methylbenzyl)-4-nonylphenol], 2,2'-methylenebis[6-(α,α -dimethylbenzyl) -4-nonylphenol], 4,4'-methylenebis(2,6-di-tert-butylphenol), 4,4'-methylenebis(6-tert-butyl-2-methylphenol), 1,1-bis(5-tert-butyl-4-hydroxy-2-methylphenyl)butane, 2,6-bis(3-tert-butyl-5-methyl-2-hydroxybenzyl)-4-methylphenol, 1,1,3-tris(5-tert-butyl-4-hydroxy -2-methylphenyl) butane, 1,1-bis(5-tert-butyl-4-hydroxy-2-methylphenyl)-

3-n-dodecylmercapto butane, ethylene glycol bis[3,3-bis(3'-tert-butyl-4'-hydroxyphenyl)butyrate], bis(3-tert-butyl-4-hydroxy-5-methylphenyl)dicyclopentadiene, bis[2-(3'-tert-butyl -2'-hydroxy-5'-methylbenzyl) -6-tert-butyl-4-methylphenyl]terephthalate, 1,1-bis-(3,5-dimethyl-2-hydroxyphenyl)butane, 2,2-bis-(3,5-di-tert-butyl-4-hydroxyphenyl)propane, 2,2-bis-(5-tert-butyl-4-hydroxy-2-methylphenyl) -4-n-dodecylmercaptobutane, 1,1,5,5-tetra-(5-tert-butyl-4-hydroxy-2-methyl phenyl)pentane, and combinations thereof may be utilized as antioxidants.

[0054] O-, N- and S-benzyl compounds, for example 3,5,3',5'-tetra-tert-butyl-4,4'-dihydroxydibenzyl ether, octadecyl-4-hydroxy-3,5-dimethylbenzylmercaptoacetate, tris-(3,5-di-tert-butyl-4-hydroxybenzyl)amine, bis(4-tert-butyl-3-hydroxy-2,6-dimethylbenzyl)dithiol terephthalate, bis(3,5-di-tert-butyl-4-hydroxybenzyl)sulfide, isooctyl-3,5di-tert-butyl-4-hydroxy benzylmercaptoacetate, and combinations thereof, may also be utilized.

[0055] Hydroxybenzylated malonates, for example dioctadecyl-2,2-bis-(3,5-di-tert-butyl-2-hydroxybenzyl)-malonate, di-octadecyl-2-(3-tert-butyl-4-hydroxy-5-methylbenzyl)-malonate, di-dodecylmercaptoethyl-2,2-bis-(3,5-di-tert-butyl-4-hydroxybenzyl)malonate, bis [4-(1,1,3,3-tetramethylbutyl)phenyl]-2,2-bis(3,5-di-tert-butyl-4-hydroxybenzyl)malonate, and combinations thereof are also suitable for use as antioxidants.

[0056] Triazine Compounds, for example 2,4-bis(octylmercapto)-6-(3,5-di-tert-butyl-4-hydroxyanilino)-1,3,5-triazine, 2-octylmercapto-4,6-bis(3,5-di-tert-butyl-4-hydroxyanilino) -1,3,5-triazine, 2-octylmercapto-4,6-bis(3,5-di-tert-butyl-4-hydroxyphenoxy) -1,3,5-triazine, 2,4,6-tris(3,5-di-tert-butyl-4-hydroxyphenoxy)-1,2,3-triazine, 1,3,5-tris(3,5-di-tert-butyl-4-hydroxybenzyl)isocyanurate, 1,3,5-tris(4-tert-butyl-3-hydroxy-2,6-dimethylbenzyl 2,4,6-tris(3,5-di-tert-butyl-4-

hydroxyphenylethyl)-1,3,5-triazine, 1,3,5-tris(3,5-di-tert-butyl-4-hydroxyphenyl propionyl)-hexahydro-1,3,5-triazine, 1,3,5-tris(3,5-dicyclohexyl-4-hydroxybenzyl)isocyanurate, and combinations thereof, may also be used.

[0057] Additional suitable, but non-limiting examples of antioxidants include aromatic hydroxybenzyl compounds, for example 1,3,5-tris-(3,5-di-tert-butyl-4-hydroxybenzyl)-2,4,6-trimethylbenzene, 1,4-bis(3,5-di-tert-butyl-4-hydroxybenzyl)-2,3,5,6-tetramethylbenzene, 2,4,6-tris(3,5-di-tert-butyl-4-hydroxybenzyl)phenol, and combinations thereof. Benzylphosphonates, for example dimethyl-2,5-di-tert-butyl-4-hydroxybenzylphosphonate, diethyl-3,5-di-tert-butyl-4-hydroxybenzylphosphonate, dioctadecyl-3,5-di-tert-butyl-4-hydroxybenzylphosphonate, dioctadecyl-5-tert-butyl-4-hydroxy-3-methylbenzylphosphonate, the calcium salt of the monoethyl ester of 3,5-di-tert-butyl-4-hydroxybenzylphosphonic acid, and combinations thereof, may also be utilized. In addition, acylaminophenols, for example 4-hydroxylauranilide, 4-hydroxystearanilide, octyl N-(3,5-di-tert-butyl-4-hydroxyphenyl)carbamate.

[0058] Esters of [3-(3,5-di-tert-butyl-4-hydroxyphenyl)propionic acid with mono- or polyhydric alcohols, e.g. with methanol, ethanol, octadecanol, 1,6-hexanediol, 1,9-nonanediol, ethylene glycol, 1,2-propanediol, neopentyl glycol, thiodiethylene glycol, diethylene glycol, triethylene glycol, pentaerythritol, tris(hydroxyethyl) isocyanurate, N,N'-bis(hydroxyethyl)oxamide, 3-thiaundecanol, 3-thiapentadecanol, trimethylhexanediol, trimethylolpropane, 4-hydroxymethyl-1-phospha-2,6,7-trioxabicyclo[2.2.2]octane, and combinations thereof, may also be used. It is further contemplated that esters of β -(5-tert-butyl-4-hydroxy-3-methylphenyl)propionic acid with mono- or polyhydric alcohols, e.g. with methanol, ethanol, octadecanol, 1,6-hexanediol, 1,9-nonanediol, ethylene glycol, 1,2-propanediol, neopentyl glycol, thiodiethylene glycol, diethylene glycol, triethylene glycol, pentaerythritol,

tris(hydroxyethyl) isocyanurate, N,N'-bis(hydroxyethyl)oxamide, 3-thiaundecanol, 3-thiapentadecanol, trimethylhexanediol, trimethylolpropane, 4-hydroxymethyl-1-phospha-2,6,7-trioxabicyclo[2.2.2]octane, and combinations thereof, may be used. Esters of 13-(3,5-dicyclohexyl-4-hydroxyphenyl)propionic acid with mono- or polyhydric alcohols, e.g. with methanol, ethanol, octadecanol, 1,6-hexanediol, 1,9-nonanediol, ethylene glycol, 1,2-propanediol, neopentyl glycol, thiodiethylene glycol, diethylene glycol, triethylene glycol, pentaerythritol, tris(hydroxyethyl) isocyanurate, N,N'-bis(hydroxyethyl)oxamide, 3-thiaundecanol, 3-thiapentadecanol, trimethylhexanediol, trimethylolpropane, 4-hydroxymethyl-1-phospha-2,6,7-trioxabicyclo[2.2.2]octane, and combinations thereof, may also be used. Moreover, esters of 3,5-di-tert-butyl-4-hydroxyphenyl acetic acid with mono- or polyhydric alcohols, e.g. with methanol, ethanol, octadecanol, 1,6-hexanediol, 1,9-nonanediol, ethylene glycol, 1,2-propanediol, neopentyl glycol, thiodiethylene glycol, diethylene glycol, triethylene glycol, pentaerythritol, tris(hydroxyethyl) isocyanurate, N,N'-bis(hydroxyethyl)oxamide, 3-thiaundecanol, 3-thiapentadecanol, trimethylhexanediol, trimethylolpropane, 4-hydroxymethyl-1-phospha-2,6,7-trioxabicyclo[2.2.2]octane, and combinations thereof, may be utilized.

[0059] Additional non-limiting examples of suitable antioxidants include those that include nitrogen, such as amides of β -(3,5-di-tert-butyl-4-hydroxyphenyl)propionic acid e.g. N,N'-bis(3,5-di-tert-butyl-4-hydroxyphenylpropionyl)hexamethylenediamine, N,N'-bis(3,5-di-tert-butyl-4-hydroxyphenylpropionyl)trimethylenediamine, N,N'-bis(3,5-di-tert-butyl-4-hydroxyphenylpropionyl)hydrazine. Other suitable non-limiting examples of antioxidant include aminic antioxidants such as N,N'-diisopropyl-p-phenylenediamine, N,N'-di-sec-butyl-p-phenylenediamine, N,N'-bis (1,4-

dimethylpentyl)-p-phenylenediamine, N,N'-bis(1-ethyl-3-methylpentyl)-p-phenylenediamine, N,N'-bis(1-methylheptyl)-p-phenylenediamine, N,N'-dicyclohexyl-p-phenylenediamine, N,N'-diphenyl-p-phenylenediamine, N,N'-bis(2-naphthyl)-p-phenylenediamine, N-isopropyl-N'-phenyl-p-phenylenediamine, N-(1,3-dimethyl-butyl)-N'-phenyl-p-phenylenediamine, N-(1-methylheptyl)-N'-phenyl-p-phenylenediamine, N-cyclohexyl-N'-phenyl-p-phenylenediamine, 4-(p-toluenesulfamoyl)diphenylamine, N,N'-dimethyl-N,N'-di-sec-butyl-p-phenylenediamine, diphenylamine, N-allyldiphenylamine, 4-isopropoxydiphenylamine, N-phenyl-1-naphthylamine, N-phenyl-2-naphthylamine, octylated diphenylamine, for example p,p'-di-tert-octyldiphenylamine, 4-n-butylaminophenol, 4-butyrylamino phenol, 4-nonanoylamino phenol, 4-dodecanoylamino phenol, 4-octadecanoylamino phenol, bis(4-methoxyphenyl)amine, 2,6-di-tert-butyl-4-dimethylamino methylphenol, 2,4'-diaminodiphenylmethane, 4,4'-diaminodiphenylmethane, N,N,N',N'-tetramethyl -4,4'-diaminodiphenylmethane, 1,2-bis[(2-methyl-phenyl)amino]ethane, 1,2-bis(phenylamino)propane, (o-tolyl)biguanide, bis[4-(1',3'-dimethylbutyl)phenyl]amine, tert-octylated N-phenyl-1-naphthylamine, a mixture of mono- and dialkylated tert-butyl/tert-octyldiphenylamines, a mixture of mono- and dialkylated isopropyl/isohexyldiphenylamines, mixtures of mono- and dialkylated tert-butyl/diphenylamines, 2,3-dihydro-3,3-dimethyl -4H-1,4-benzothiazine, phenothiazine, N-allylphenothiazine, N,N,N',N'-tetraphenyl -1,4-diaminobut-2-ene, N,N-bis(2,2,6,6-tetramethylpiperid-4-yl-hexamethylenediamine, bis(2,2,6,6-tetramethyl piperid-4-yl)sebacate, 2,2,6,6-tetramethylpiperidin-4-one and 2,2,6,6-tetramethyl piperidin-4-ol, and combinations thereof.

[0060] Even further non-limiting examples of suitable antioxidants includes aliphatic

or aromatic phosphites, esters of thiodipropionic acid or of thiodiacetic acid, or salts of dithiocarbamic or dithiophosphoric acid, 2,2,12,12-tetramethyl-5,9-dihydroxy-3,7,1-trithiatridecane and 2,2,15,15-tetramethyl-5,12-dihydroxy-3,7,10,14-tetrathiahexadecane, and combinations thereof. Furthermore, sulfurized fatty esters, sulfurized fats and sulfurized olefins, and combinations thereof, may be used. It is also contemplated that the antioxidant may be as described in U.S. Prov. Ser. No. 61/231,468, filed on August 5, 2009, the disclosure of which is expressly incorporated herein by reference in its entirety.

[0061] The one or more antioxidants are not particularly limited in amount in the composition but are typically present in an amount of from 0.1 to 2, 0.5 to 2, 1 to 2, or 1.5 to 2, parts by weight per 100 parts by weight of the composition. Alternatively, the one or more antioxidants may be present in amounts of less than 2, less than 1.5, less than 1, or less than 0.5, parts by weight per 100 parts by weight of the composition. Of course, the weight percent of the one or more antioxidants may be any value or range of values, both whole and fractional, within those ranges and values described above and/or may be present in amounts that vary from the values and/or range of values above by $\pm 5\%$, $\pm 10\%$, $\pm 15\%$, $\pm 20\%$, $\pm 25\%$, $\pm 30\%$, etc.

Metal Deactivators:

[0062] In various embodiments, one or more metal deactivators can be included in the composition. Suitable, non-limiting examples of the one or more metal deactivators include benzotriazoles and derivatives thereof, for example 4- or 5-alkylbenzotriazoles (e.g. tolutriazole) and derivatives thereof, 4,5,6,7-tetrahydrobenzotriazole and 5,5'-methylenebisbenzotriazole; Mannich bases of benzotriazole or tolutriazole, e.g. 1-[bis(2-ethylhexyl)aminomethyl]tolutriazole and 1-[bis(2-ethylhexyl)aminomethyl]benzotriazole; and alkoxyalkylbenzotriazoles such as

1-(nonyloxymethyl)benzotriazole, 1-(1-butoxyethyl)benzotriazole and 1-(1-cyclohexyloxybutyl)tolutriazole, and combinations thereof.

[0063] Additional non-limiting examples of the one or more metal deactivators include 1,2,4-triazoles and derivatives thereof, for example 3-alkyl(or aryl)-1,2,4-triazoles, and Mannich bases of 1,2,4-triazoles, such as 1-[bis(2-ethylhexyl)aminomethyl]-1,2,4-triazole; alkoxyalkyl-1,2,4-triazoles such as 1-(1-butoxyethyl)-1,2,4-triazole; and acylated 3-amino-1,2,4-triazoles, imidazole derivatives, for example 4,4'-methylenebis(2-undecyl-5-methylimidazole) and bis[(N-methyl)imidazol-2-yl]carbinol octyl ether, and combinations thereof.

[0064] Further non-limiting examples of the one or more metal deactivators include sulfur-containing heterocyclic compounds, for example 2-mercaptobenzothiazole, 2,5-dimercapto-1,3,4-thiadiazole and derivatives thereof; and 3,5-bis[di(2-ethylhexyl)aminomethyl]-1,3,4-thiadiazolin-2-one, and combinations thereof. Even further non-limiting examples of the one or more metal deactivators include amino compounds, for example salicylidenepropylenediamine, salicylaminoguanidine and salts thereof, and combinations thereof. It is also contemplated that the metal deactivator may be as described in U.S. Prov. Ser. No. 61/231,468, filed on August 5, 2009, the disclosure of which is expressly incorporated herein by reference in its entirety.

[0065] The one or more metal deactivators are not particularly limited in amount in the composition but are typically present in an amount of from 0.01 to 0.1, from 0.05 to 0.01, or from 0.07 to 0.1, parts by weight per 100 parts by weight of the composition. Alternatively, the one or more metal deactivators may be present in amounts of less than 0.1, of less than 0.7, or less than 0.5, parts by weight per 100 parts by weight of the composition. The weight percent of the one or more metal

deactivators may be any value or range of values, both whole and fractional, within those ranges and values described above and/or may be present in amounts that vary from the values and/or range of values above by $\pm 5\%$, $\pm 10\%$, $\pm 15\%$, $\pm 20\%$, $\pm 25\%$, $\pm 30\%$, etc.

Rust Inhibitors and Friction Modifiers:

[0066] In various embodiments, one or more rust inhibitors and/or friction modifiers can be included in the composition. Suitable, non-limiting examples of the one or more rust inhibitors and/or friction modifiers include organic acids, their esters, metal salts, amine salts and anhydrides, for example alkyl- and alkenylsuccinic acids and their partial esters with alcohols, diols or hydroxycarboxylic acids, partial amides of alkyl- and alkenylsuccinic acids, 4-nonylphenoxyacetic acid, alkoxy- and alkoxyethoxycarboxylic acids such as dodecyloxyacetic acid, dodecyloxy(ethoxy)acetic acid and the amine salts thereof, and also N-oleoylsarcosine, sorbitan monooleate, lead naphthenate, alkenylsuccinic anhydrides, for example dodecenylsuccinic anhydride, 2-carboxymethyl-1-dodecyl-3-methylglycerol and the amine salts thereof, and combinations thereof. Additional suitable, non-limiting examples of the one or more rust inhibitors and/or friction modifiers include nitrogen-containing compounds, for example, primary, secondary or tertiary aliphatic or cycloaliphatic amines and amine salts of organic and inorganic acids, for example oil-soluble alkylammonium carboxylates, and also 1-[N,N-bis(2-hydroxyethyl)amino]-3-(4-nonylphenoxy)propan-2-ol, and combinations thereof. Further suitable, non-limiting examples of the one or more rust inhibitors and/or friction modifiers include heterocyclic compounds, for example: substituted imidazolines and oxazolines, and 2-heptadecenyl-1-(2-hydroxyethyl)imidazoline, phosphorus-containing compounds, for example: Amine salts of phosphoric acid

partial esters or phosphonic acid partial esters, and zinc dialkyldithiophosphates, molybdenum-containing compounds, such as molybdenum dithiocarbamate and other sulphur and phosphorus containing derivatives, sulfur-containing compounds, for example: barium dinonylnaphthalenesulfonates, calcium petroleum sulfonates, alkylthio-substituted aliphatic carboxylic acids, esters of aliphatic 2-sulfocarboxylic acids and salts thereof, glycerol derivatives, for example: glycerol monooleate, 1-(alkylphenoxy)-3-(2-hydroxyethyl)glycerols, 1-(alkylphenoxy)-3-(2,3-dihydroxypropyl) glycerols and 2-carboxyalkyl-1,3-dialkylglycerols, and combinations thereof. It is also contemplated that the rust inhibitors and friction modifiers may be as described in U.S. Prov. Ser. No. 61/231,468, filed on August 5, 2009, the disclosure of which is expressly incorporated herein by reference in its entirety.

[0067] The one or more rust inhibitors and friction modifiers are not particularly limited in amount in the composition but are typically present in an amount of from 0.05 to 0.5, 0.01 to 0.2, from 0.05 to 0.2, 0.1 to 0.2, 0.15 to 0.2, or 0.02 to 0.2, parts by weight per 100 parts by weight of the composition. Alternatively, the one or more rust inhibitors and friction modifiers may be present in amounts of less than 0.5, less than 0.4, less than 0.3, less than 0.2, less than 0.1, less than 0.5, or less than 0.1, parts by weight per 100 parts by weight of the composition. The weight percent of the one or more rust inhibitors and friction modifiers may be any value or range of values, both whole and fractional, within those ranges and values described above and/or may be present in amounts that vary from the values and/or range of values above by $\pm 5\%$, $\pm 10\%$, $\pm 15\%$, $\pm 20\%$, $\pm 25\%$, $\pm 30\%$, etc.

Viscosity Index Improvers:

[0068] In various embodiments, one or more viscosity index improvers can be

included in the composition. Suitable, non-limiting examples of the one or more viscosity index improvers include polyacrylates, polymethacrylates, vinylpyrrolidone/methacrylate copolymers, polyvinylpyrrolidones, polybutenes, olefin copolymers, styrene/acrylate copolymers and polyethers, and combinations thereof. It is also contemplated that the viscosity index improvers may be as described in U.S. Prov. Ser. No. 61/231,468, filed on August 5, 2009, the disclosure of which is expressly incorporated herein by reference in its entirety.

[0069] The one or more viscosity index improvers are not particularly limited in amount in the composition but are typically present in an amount of from 1 to 1, from 2 to 8, from 3 to 7, from 4 to 6, or from 4 to 5, parts by weight per 100 parts by weight of the composition. Alternatively, the one or more viscosity index improvers may be present in an amount of less than 10, 9, 8, 7, 6, 5, 4, 3, 2, or 1, part by weight per 100 parts by weight of the composition. The weight percent of the one or more viscosity index improvers may be any value or range of values, both whole and fractional, within those ranges and values described above and/or may be present in amounts that vary from the values and/or range of values above by $\pm 5\%$, $\pm 10\%$, $\pm 15\%$, $\pm 20\%$, $\pm 25\%$, $\pm 30\%$, etc.

Pour Point Depressants:

[0070] In various embodiments, one or more pour point depressants can be included in the composition. Suitable, non-limiting examples of the pour point depressants include polymethacrylate and alkylated naphthalene derivatives, and combinations thereof. It is also contemplated that the pour point depressants may be as described in U.S. Prov. Ser. No. 61/231,468, filed on August 5, 2009, the disclosure of which is expressly incorporated herein by reference in its entirety.

[0071] The one or more pour point depressants are not particularly limited in amount

in the composition but are typically present in an amount of from 0.1 to 1, from 0.5 to 1, or from 0.7 to 1, part by weight per 100 parts by weight of the composition. Alternatively, the one or more pour point depressants may be present in amounts of less than 1, less than 0.7, or less than 0.5, parts by weight per 100 parts by weight of the composition. The weight percent of the one or more pour point depressants may be any value or range of values, both whole and fractional, within those ranges and values described above and/or may be present in amounts that vary from the values and/or range of values above by $\pm 5\%$, $\pm 10\%$, $\pm 15\%$, $\pm 20\%$, $\pm 25\%$, $\pm 30\%$, etc.

Dispersants:

[0072] In various embodiments, one or more dispersants can be included in the composition.

Suitable, non-limiting examples of the one or more dispersants include polybutenylsuccinic amides or -imides, polybutenylphosphonic acid derivatives and basic magnesium, calcium and barium sulfonates and phenolates, succinate esters and alkylphenol amines (Mannich bases), and combinations thereof. It is also contemplated that the dispersants may be as described in U.S. Prov. Ser. No. 61/231,468, filed on August 5, 2009, the disclosure of which is expressly incorporated herein by reference in its entirety.

[0073] The one or more dispersants are not particularly limited in amount in the composition but are typically present in an amount of from 0.1 to 5, from 0.5 to 4.5, from 1 to 4, from 1.5 to 3.5, from 2 to 3, or from 2.5 to 3, parts by weight per 100 parts by weight of the composition. Alternatively, the one or more dispersants may be present in an amount of less than 5, 4.5, 3.5, 3, 2.5, 2, 1.5, or 1, part by weight per 100 parts by weight of the composition. The weight percent of the one or more dispersants may be any value or range of values, both whole and fractional, within those ranges

and values described above and/or may be present in amounts that vary from the values and/or range of values above by $\pm 5\%$, $\pm 10\%$, $\pm 15\%$, $\pm 20\%$, $\pm 25\%$, $\pm 30\%$, etc.

Detergents:

[0074] In various embodiments, one or more detergents can be included in the composition. Suitable, non-limiting examples of the one or more detergents include overbased or neutral metal sulphonates, phenates and salicylates, and combinations thereof. It is also contemplated that the detergents may be as described in U.S. Prov. Ser. No. 61/231,468, filed on August 5, 2009, the disclosure of which is expressly incorporated herein by reference in its entirety.

[0075] The one or more detergents are not particularly limited in amount in the composition but are typically present in an amount of from .1 to 5, from 0.5 to 4.5, from 1 to 4, from 1.5 to 3.5, from 2 to 3, or from 2.5 to 3, parts by weight per 100 parts by weight of the composition. Alternatively, the one or more detergents may be present in an amount of less than 5, 4.5, 3.5, 3, 2.5, 2, 1.5, or 1, part by weight per 100 parts by weight of the composition. The weight percent of the one or more detergents may be any value or range of values, both whole and fractional, within those ranges and values described above and/or may be present in amounts that vary from the values and/or range of values above by $\pm 5\%$, $\pm 10\%$, $\pm 15\%$, $\pm 20\%$, $\pm 25\%$, $\pm 30\%$, etc.

[0076] In various embodiments, the composition is substantially free of water, e.g. includes less than 5, 4, 3, 2, or 1, weight percent of water. Alternatively, the composition may include less than 0.5 or 0.1 weight percent of water or may be free of water. Of course, the weight percent of the water may be any value or range of values, both whole and fractional, within those ranges and values described above

and/or may be present in amounts that vary from the values and/or range of values above by $\pm 5\%$, $\pm 10\%$, $\pm 15\%$, $\pm 20\%$, $\pm 25\%$, $\pm 30\%$, etc.

[0077] The instant invention also provides an additive concentrate package which includes one or more metal deactivators, one or more antioxidants, one or more anti-wear additives, and the one or more alkylethercarboxylic acid corrosion inhibitor of this invention. In various embodiments, the additive concentrate package may include one or more additional additives as described above. The additive package may be included in the composition in amounts of from 0.1 to 1, from 0.2 to 0.9, from 0.3 to 0.8, from 0.4 to 0.7, or from 0.5 to 0.6, parts by weight per 100 parts by weight of the composition. The weight percent of the additive concentrate package may be any value or range of values, both whole and fractional, within those ranges and values described above and/or may be present in amounts that vary from the values and/or range of values above by $\pm 5\%$, $\pm 10\%$, $\pm 15\%$, $\pm 20\%$, $\pm 25\%$, $\pm 30\%$, etc.

[0078] Some of the compounds described above may interact in the lubricant composition, so the components of the lubricant composition in final form may be different from those components that are initially added or combined together. Some products formed thereby, including products formed upon employing the composition of this invention in its intended use, are not easily described or describable. Nevertheless, all such modifications, reaction products, and products formed upon employing the composition of this invention in its intended use, are expressly contemplated and hereby included herein. Various embodiments of this invention include one or more of the modification, reaction products, and products formed from employing the composition, as described above.

Biodiesel Fuel:

[0079] The composition may include biodiesel fuel. Alternatively, the composition may be diluted with biodiesel fuel. The terminology “diluted with biodiesel fuel” typically described the lubricant composition including, or being contaminated with, at least 1 weight percent of the biodiesel fuel. The composition is typically contaminated with the biodiesel fuel as a result of “blow by” during operation of diesel engines. Fuel dilution into engine oil typically cannot be easily prevented. In one embodiment, the terminology “diluted with” refers to the composition being diluted with the biodiesel fuel during operation of a diesel engine.

[0080] The composition is protected against dilution with the biodiesel in that the components (i.e., the antioxidants (B) and (C)) minimize the negative effects that typically result from dilution of engine oils with biodiesel fuel. Typically, the terminology “dilution” refers to contamination of the composition with biodiesel fuel. Dilution or contamination typically occurs at about 1 weight percent of biodiesel fuel in the composition. In various embodiments, composition is diluted or contaminated with from about 1 to 50, from about 5 to 50, from about 10 to 40, from about 10 to 30, from about 20 to 30, from about 5 to 30, from about 5 to 10, from about 5 to 15, from about 5 to 20, from about 5 to 25, from about 5 to 35, from about 5 to 40, or from about 5 to 50, weight percent of biodiesel fuel. The weight percent of the biodiesel fuel may be any value or range of values, both whole and fractional, within those ranges and values described above and/or may be present in amounts that vary from the values and/or range of values above by $\pm 5\%$, $\pm 10\%$, $\pm 15\%$, $\pm 20\%$, $\pm 25\%$, $\pm 30\%$, etc.

[0081] Biodiesel fuel typically includes lower alkyl fatty acid esters, prepared, for example, by transesterifying triglycerides with lower alcohols, e.g. methanol or

ethanol. A typical biodiesel fuel is the fatty acid methyl ester of rapeseed oil or of soy oil. Sources for biodiesel fuel include vegetable and animal sources. Recycled cooking oil may be a source of biodiesel fuel. Various types of biodiesel fuel and their preparation are taught, for example, in U.S. Pat. Nos. 5,578,090, 5,713,965, 5,891,203, 6,015,440, 6,174,501 and 6,398,707, each of which is hereby incorporated by reference. It is also contemplated that the biodiesel fuel may be as described in U.S. Prov. Ser. No. 61/231,468, filed on August 5, 2009, the disclosure of which is expressly incorporated herein by reference in its entirety.

[0082] Typically, the biodiesel fuel includes lower alkyl esters of a mixture of saturated and unsaturated straight chain fatty acids of from 12 to 22 carbon atoms, derived from vegetable or oleaginous seeds. In various embodiments, the terminology "lower alkyl ester" describes C₁-C₅ esters, in particular methyl and ethyl esters. Mixtures of methyl esters of saturated, monounsaturated and polyunsaturated C₁₃-C₂₂ fatty acids are typically referred to as "biodiesel" or "fatty acid methyl esters" (FAME).

[0083] Biodiesel derived from vegetable sources such as soy, rapeseed, corn, palm, coconut or sunflower oils are typically referred to in the art as First Generation biodiesel fuels. Second Generation biodiesel fuels are typically derived from non-food sources such as jatropha, algae, yeast, used cooking oil, animal fat (tallow) or castor oil. Third Generation biodiesel fuels are typically derived from further sources such as wood/lignocelluloses or biomass. The biodiesel fuel of this invention may include one or more of the aforementioned types. In one embodiment, the biodiesel fuel includes at least one fatty acid methyl ester of a vegetable or oleaginous seed oil.

[0084] In one embodiment, the biodiesel fuel includes 100 wt % of lower alkyl fatty acid esters or a combination of lower alkyl fatty acid esters combined with traditional

petroleum diesel fuel. In various alternative embodiments, the biodiesel fuel includes from about 2 to about 98 weight percent fatty acid ester and from about 98 to about 2 weight percent petroleum diesel fuel. In one example, the biodiesel fuel includes from about 10 to about 90 weight percent fatty acid ester and from about 90 to about 10 weight percent diesel. In another example, the biodiesel fuel includes from about 25 to about 75 weight percent fatty acid ester and from about 75 to about 25 weight percent diesel fuel. The invention is not limited to those amounts described above. The weight percent of the lower alkyl fatty acid esters and/or diesel fuel may be any value or range of values, both whole and fractional, within those ranges and values described above and/or may be present in amounts that vary from the values and/or range of values above by $\pm 5\%$, $\pm 10\%$, $\pm 15\%$, $\pm 20\%$, $\pm 25\%$, $\pm 30\%$, etc.

[0085] In one embodiment, the base oil is further defined as an API Group II base oil, said (B) at least one diphenylamine antioxidant is further defined as an octylated/butylated diphenylamine, and said (C) at least one antioxidant comprises octylated phenyl-alpha-naphthylamine, and (B) and (C) are present in a combined amount of from about 0.5 to 3 parts by weight per 100 parts by weight of said base oil.

Method of Forming the Lubricant Composition:

[0086] This invention also provides a method of improving the performance of the composition. The method includes the steps of providing the (A) base oil, providing the (B) at least one diphenylamine antioxidant, providing the (C) at least one antioxidant, and combining (A), (B), and (C) to form the lubricant composition.

Evaluation According to ASTM D 6186:

[0087] In the method, the base oil has an initial oxidation value measured according to ASTM D 6186. Typically, this value is measured in the absence of (B) and (C).

More specifically, the base oil is evaluated according to ASTM D 6186 to determine an initial oxidation value that represents a pristine condition of the base oil as originally designed and commercially sold (typically without any of the antioxidants (B) and (C) or any other extraneous additives not already present in the base oil as commercially sold). In other embodiments, the base oil can be evaluated according to SAE 940793 in conjunction with, or instead of, ASTM D 6186. The test procedure for SAE 940793 is described in the SAE paper of the same title. After the initial oxidation value is determined, an intermediate oxidation value can be determined, if desired, using one or both methods described above. The intermediate oxidation value can be determined if the composition is diluted with, or includes, biodiesel fuel. The intermediate oxidation value is typically only measured for analytical purposes. The amount of biodiesel fuel added to the composition is not particularly limited. Due to the tendency of the biodiesel fuel to oxidize and form oxidative by-products, the intermediate oxidation values are lower than the initial oxidation values and represent a degraded condition that is harmful to the diesel engines in which such base oils could be used. Of course, intermediate oxidation values are not typically measured in working diesel engines and conditions that would give rise to such intermediate oxidation values are preferably avoided all together in working engines because if the base oil was degraded to such a degree in a working engine, failure of the oil, and damage to the engine, could result. To avoid this situation, premature replacement of the oil would be needed.

[0088] In addition in the method, the composition has a final oxidation value measured according to ASTM D 6186 that is equal to or greater than the initial oxidation value of the (A) base oil when the composition is measured containing up to about 6 wt % of the biodiesel fuel. It is to be understood that the composition is not

limited to including up to about 6 wt % but is typically evaluated when it contains this amount of biodiesel fuel. In other words, and as described above, the amount of biodiesel fuel in the composition can vary and may exceed 6 wt %. Typically, the amount is from 0.5 to 6, from 1 to 5.5, from 1.5 to 5, from 2 to 4.5, from 2.5 to 4, or from 3 to 3.5, parts by weight per 100 parts by weight of the composition. In alternative embodiments, and as also described above, the biodiesel may be present in an amount from about 1 to 50, from about 5 to 50, from about 10 to 40, from about 10 to 30, from about 20 to 30, from about 5 to 30, from about 5 to 10, from about 5 to 15, from about 5 to 20, from about 5 to 25, from about 5 to 35, from about 5 to 40, or from about 5 to 50, parts by weight of the biodiesel fuel per 100 parts by weight of the composition. Of course, any value or range of values, both whole and fractional, within those ranges and values described above may be utilized. Alternatively, the biodiesel fuel may be present in amounts that vary from the values and/or range of values above by $\pm 5\%$, $\pm 10\%$, $\pm 15\%$, $\pm 20\%$, $\pm 25\%$, $\pm 30\%$, etc. Varying the amount of biodiesel fuel in the composition changes the intermediate oxidation value. Typically, increased amounts of biodiesel fuel decrease the intermediate oxidation value. In one embodiment, the composition is diluted with the biodiesel fuel in a lubricant sump of a diesel engine.

[0089] After the initial oxidation value is determined, the final oxidation value, as first introduced above, can then be measured using one or both methods also described above. The final oxidation value can be measured using the same amount of the biodiesel fuel in the composition as described above. In other words, even if the intermediate value is not determined, the same amounts of biodiesel fuels can be used to determine the final oxidation value. In one embodiment, the final oxidation value is determined when up to about 6 wt % of the biodiesel fuel is present in the

composition in addition to (A), (B), and (C). When the antioxidants (B) and (C) of this invention are utilized, the final oxidation value of the composition tends to be equal to or greater than the initial oxidation value of the (A) base oil. This indicates that the antioxidants (B) and (C) of this invention at least restore the pristine quality of the base oil to at least its original condition even after degradation/dilution with/addition of the biodiesel fuel and oxidative by-products formed therefrom. If the final oxidation value is greater than the initial oxidation value, then such data indicated that the antioxidants (B) and (C) of this invention improve the quality of the base oil (even after degradation/dilution with/addition of the biodiesel fuel and oxidative by-products formed therefrom) to a level that is even better and more preferred than its original quality. In various embodiments, it is contemplated that the final oxidation value may be within (i.e., \pm) about, 5, 4, 3, 2, or 1, percent of the initial oxidation value.

[0090] In one embodiment, the (A) base oil has an initial oxidation value measured in the absence of (B) and (C) and measured according to ASTM D 6186, wherein the lubricant composition has a final oxidation value measured when comprising (A), (B) and (C) and up to about 6 wt % of a biodiesel fuel and measured according to ASTM D 6186, and wherein the final oxidation value of the lubricant composition is equal to or greater than the initial oxidation value of the (A) base oil. In a related embodiment, the composition includes from 0.3 to 7 parts by weight of the (B) and (C) antioxidants per 100 parts by weight of the lubricant composition. In alternative related embodiments, the composition includes from 0.9 to 3.5 parts by weight of the (B) and (C) antioxidants per 100 parts by weight of the lubricant composition. In another related embodiment, the composition includes less than about 2.1 parts by weight of the (B) and (C) antioxidants per 100 parts by weight of the lubricant composition.

EXAMPLES

[0091] Two mixtures of antioxidants (Mixtures A and B) are formed according to this invention. Three comparative mixtures (Comparative Mixtures C, D, and E) are also formed but do not represent this invention.

[0092] More specifically, Mixture A is an 80/20 weight ratio of a mixture of octylated/butylated diphenylamine and thiodiethylene bis[3-(3,5-di-tert-butyl-4-hydroxyphenyl)propionate].

[0093] Mixture B is an 80/20 weight ratio of a mixture of octylated/butylated diphenylamine and octylated phenyl-alpha-naphthylamine.

[0094] Comparative Mixture C is a diisobutylene reaction product of a mixture of diphenylamine and phenothiazine as prepared according to Example 1 of U.S. Pat. No. 5,503,759.

[0095] Comparative Mixture D is a 1/1 weight ratio of a mixture of octylated/butylated diphenylamine and 3-(3,5-di-tert-butyl-4-hydroxyphenyl)propionic acid isooctyl ester.

[0096] Comparative Mixture E is a 1/1 weight ratio of a mixture of octylated/butylated diphenylamine and 4,4-methylene-bis(2,6-di-tert-butylphenol).

General Procedure:

[0097] A 15W-40 oil (i.e., heavy duty diesel engine oil; HDEO;) is independently evaluated according to ASTM D 6186 and SAE 940793 to determine an initial oxidation value that represents a pristine condition of the oil as originally designed and commercially sold. It is to be understood that the 15W-40 oil, in this instance, can alternatively be described as one embodiment of a generic "base oil" introduced above. Subsequently, samples the 15W-40 oil are contaminated with 2 or 6 wt % of varying types of aged biodiesel fuels (i.e., soy methyl ester, rapeseed methyl ester,

palm methyl ester, or coconut methyl ester). After contamination, the samples are again independently evaluated according to ASTM D 6186 and SAE 940793 to determine intermediate oxidation values. Due to the tendency of the aged biodiesel fuels to oxidize and form oxidative by-products, the intermediate oxidation values are lower than the initial oxidation values and represent a degraded condition that is harmful to the diesel engines in which such 15W-40 oils could be used.

[0098] Subsequently, various amounts of the Mixtures A and B and the Comparative Mixtures C-E are combined with the samples of the 15W-40 oils/biodiesel fuels to form Compositions A and B (of this invention) and Comparative Compositions C-E, each of which includes various amounts of the respective Mixtures. After formation, these Compositions are then independently evaluated according to ASTM D 6186 and SAE 940793 to determine final oxidation values. In other words, the various amounts of the Mixtures A and B and the Comparative Mixtures C-E are added to the samples of the 15W-40 oils/biodiesel fuels to increase the intermediate oxidation values up to at least pristine condition. Said differently, ASTM D 6186 and SAE 940793 are utilized to determine a quantity of the Mixtures needed to be used such that the final oxidation values of the Compositions are equal to or even greater than the initial oxidation values of the oil itself. Said even a different way, these tests are used to determine how much of the Mixtures are needed to return the 15W-40 oil to its pristine condition or to a condition that is even better than the pristine/original condition. A condition that is even better than the pristine/original condition is represented by a final oxidation value that is higher than the initial oxidation value.

[0099] ASTM D 6186 is a Standard Test Method for Oxidation Induction Time of Lubricating Oils by Pressure Differential Scanning Calorimetry (PDSC). In this method, a small quantity of oil is weighted into a sample pan and placed in a test cell.

The cell is heated to a specified temperature and then pressurized with oxygen. The cell is held at a regulated temperature and pressure until an exothermic reaction occurs. The extrapolated onset time is measured and reported as the oxidation induction time for the 15W-40 oil at the specified test temperature. More specifically, ASTM D 6186 is conducted at 150 psi and used to evaluate thin film oxidation. Oxidation induction time is measured at isothermal conditions at 200°C via high pressure differential scanning calorimetry.

[00100] SAE 940793 is also described as a Viscosity Increase Test (VIT) and is described in SAE Paper #940793. In this method, iron (III) acetylacetonate degradation catalyst is added to 30 grams of the 15W-40 oil in a glass oxidation tube. The tube is heated to 160C in an oil bath and oxygen is bubbled through the 15W-40 oil. Samples are withdrawn periodically to determine the increase in kinematic viscosity of the 15W-40 oil. These measurements are plotted and the time to 375% viscosity increase is determined by graphic interpolation. More specifically, SAE 940793 is conducted to determine viscosity increase and bulk oxidation test 160°C with soluble iron catalyst.

[00101] The biodiesel described above is a methyl ester of soy, rapeseed, palm, or coconut oil and is aged for 20 hours at 110°C under an air flow of 15 mL/min. This ageing is done to simulate oxidative degradation during combustion in diesel engines.

[00102] Table 1 below sets forth the weight percent of the Mixtures needed to restore the original ASTM D 6186 value of the 15W-40 oil when the various biodiesel fuels are added to the 15W-40 oil at 2 or 6 weight percent.

TABLE 1

	Weight Percent Biodiesel Fuel Added to 15W-40 Oil							
	Aged Soy Methyl Ester		Aged Rapeseed Methyl Ester		Aged Palm Methyl Ester		Aged Coconut Methyl Ester	
	2 wt %	6 wt %	2 wt %	6 wt %	2 wt %	6 wt %	2 wt %	6 wt %
Mixture A	1.35	1.85	1.3	1.6	1.2	2.0	1.0	2.1
Mixture B	0.90	1.50	<1	1.3	<1	2.0	<1	<1
Comp. Mixture C	1.25	1.60	N/A	N/A	N/A	N/A	N/A	N/A
Comp. Mixture D	3.00	3.6	2.9	>3	~2	>3	3.0	>3
Comp. Mixture E	2.65	3.5	2.8	>3	>3	>3	2.7	2.9

* Mixtures A and B are utilized at 80/20 weight ratios and not at 1:1 ratios because these Mixtures are not liquid at 1:1 ratios and thus cannot be evaluated

[00103] Table 2 below sets forth the weight percent of the Mixtures needed to restore the original viscosity (VIT; SAE 0407930) of the 15W-40 oil when the various biodiesel fuels are added to the 15W-40 oil at 2 or 6 weight percent.

TABLE 2

Mixture	Weight Percent Biodiesel Fuel Added to 15W-40 Oil							
	Aged Soy Methyl Ester		Aged Rapeseed Methyl Ester		Aged Palm Methyl Ester		Aged Coconut Methyl Ester	
	2 wt %	6 wt %	2 wt %	6 wt %	2 wt %	6 wt %	2 wt %	6 wt %
Mixture A	3.0	>3	<1	3.3	<1	<1	<1	<1
Mixture B	1.85	>3	<1	3.4	<1	1.4	1.4	<1
Comp. Mixture C	>3	>3	N/A	N/A	N/A	N/A	N/A	N/A
Comp. Mixture D	>3	>3	<1	>3	<1	<1	<1	<1
Comp. Mixture E	>3	>3	<1	>3	<1	<1	<1	<1

[00104] The data set forth represents a summary of a larger data set that is set forth in the line graphs of Figures 1-16. In some of Figures 1-16, Mixture C is not evaluated. Some of the methyl ester contamination of the HDEO is relatively mild relative to

oxidative impact. The methyl esters associated with the mild impact tend to be more oxidatively stable due to the decreased unsaturation of their compositions. As a result, these methyl esters present less of a practical problem relative to contamination. The 15W-40 oils including these methyl esters are returned to their original conditions using less than 1 wt % of the Mixtures. Such results are indicated in the above tables as “<1.”

[00105] The data set forth above generally indicates that the impact of adding 6 weight percent of the biodiesel fuels to the 15W-40 oil and Mixtures of this invention results in a reduction of about 45 minutes of the oxidation induction time. The data set forth above also indicates that the impact of adding 2 weight percent of the biodiesel fuels to the 15W-40 oil and Mixtures results in a reduction of about 24 minutes of the oxidation induction time. The data also indicates the impact of adding 6 weight percent of the biodiesel fuels to the 15W-40 oil and Mixtures of this invention results in a reduction of 81 hours to reach a 375% viscosity increase at 160°C. Even further, the data indicates that the impact of adding 2 weight percent of the biodiesel fuels to the 15W-40 oil and Mixtures of this invention results in a reduction of 70 hours to reach a 375% viscosity increase at 160°C. Accordingly, the data evidences that the Mixtures of this invention are superior at protection engine oil contaminated with biodiesel against oxidation.

[00106] It is to be understood that the appended claims are not limited to express and particular compounds, compositions, or methods described in the detailed description, which may vary between particular embodiments which fall within the scope of the appended claims. With respect to any Markush groups relied upon herein for describing particular features or aspects of various embodiments, it is to be appreciated that different, special, and/or unexpected results may be obtained from

each member of the respective Markush group independent from all other Markush members. Each member of a Markush group may be relied upon individually and or in combination and provides adequate support for specific embodiments within the scope of the appended claims.

[00107] It is also to be understood that any ranges and subranges relied upon in describing various embodiments of the present invention independently and collectively fall within the scope of the appended claims, and are understood to describe and contemplate all ranges including whole and/or fractional values therein, even if such values are not expressly written herein. One of skill in the art readily recognizes that the enumerated ranges and subranges sufficiently describe and enable various embodiments of the present invention, and such ranges and subranges may be further delineated into relevant halves, thirds, quarters, fifths, and so on. As just one example, a range “of from 0.1 to 0.9” may be further delineated into a lower third, i.e., from 0.1 to 0.3, a middle third, i.e., from 0.4 to 0.6, and an upper third, i.e., from 0.7 to 0.9, which individually and collectively are within the scope of the appended claims, and may be relied upon individually and/or collectively and provide adequate support for specific embodiments within the scope of the appended claims. In addition, with respect to the language which defines or modifies a range, such as “at least,” “greater than,” “less than,” “no more than,” and the like, it is to be understood that such language includes subranges and/or an upper or lower limit. As another example, a range of “at least 10” inherently includes a subrange of from at least 10 to 35, a subrange of from at least 10 to 25, a subrange of from 25 to 35, and so on, and each subrange may be relied upon individually and/or collectively and provides adequate support for specific embodiments within the scope of the appended claims. Finally, an individual number within a disclosed range may be relied upon and

provides adequate support for specific embodiments within the scope of the appended claims. For example, a range “of from 1 to 9” includes various individual integers, such as 3, as well as individual numbers including a decimal point (or fraction), such as 4.1, which may be relied upon and provide adequate support for specific embodiments within the scope of the appended claims.

[00108] The invention has been described in an illustrative manner, and it is to be understood that the terminology which has been used is intended to be in the nature of words of description rather than of limitation. Many modifications and variations of the present invention are possible in light of the above teachings, and the invention may be practiced otherwise than as specifically described.

CLAIMS

What is claimed is:

1. A lubricant composition suitable for use in a diesel engine and resistant to degradation by oxidative by-products of biodiesel fuel, said composition comprising:

A. a base oil;

B. at least one diphenylamine antioxidant; and

C. at least one antioxidant selected from a sulfur containing phenolic antioxidant, a phenyl-alpha-naphthylamine antioxidant, and combinations thereof.

2. A lubricant composition as set forth in claim 1 wherein said (C) at least one antioxidant comprises both said sulfur containing phenolic antioxidant and said phenyl-alpha-naphthylamine antioxidant.

3. A lubricant composition as set forth in claim 1 wherein said (C) at least one antioxidant comprises said sulfur containing phenolic antioxidant

4. A lubricant composition as set forth in claim 1 wherein said (C) at least one antioxidant consists essentially of said sulfur containing phenolic antioxidant.

5. A lubricant composition as set forth in claim 4 wherein said (C) at least one antioxidant is free of said phenyl-alpha-naphthylamine antioxidant.

6. A lubricant composition as set forth in claim 1 wherein said (C) at least one antioxidant comprises said phenyl-alpha-naphthylamine antioxidant.

7. A lubricant composition as set forth in claim 1 wherein said (C) at least one antioxidant consists essentially of said phenyl-alpha-naphthylamine antioxidant.

8. A lubricant composition as set forth in claim 7 wherein said (C) at least one antioxidant is free of said sulfur containing phenolic antioxidant.

9. A lubricant composition as set forth in any one of claims 1, 2, or 6-8

wherein said phenyl-alpha-naphthylamine antioxidant is further defined as having the formula:

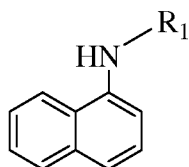

and wherein R₁ is an aryl radical having from 6 to 12 carbon atoms or an aryl radical having from 6 to 20 carbon atoms and substituted by one, two or three straight or branched chain alkyl radicals each having from 1 to 18 carbon atoms.

10. A lubricant composition as set forth in any one of claims 1-9 wherein said (B) at least one diphenylamine antioxidant is further defined as having the formula:

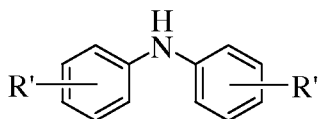

wherein each R' is independently a hydrogen atom, a straight or branched chain alkyl radical having from 1 to 18 carbon atoms, or an aralkyl radical having 7 to 14 carbon atoms;

wherein said (C) at least one antioxidant comprises said sulfur containing phenolic antioxidant and said sulfur containing phenolic antioxidant is further defined as having the formula:

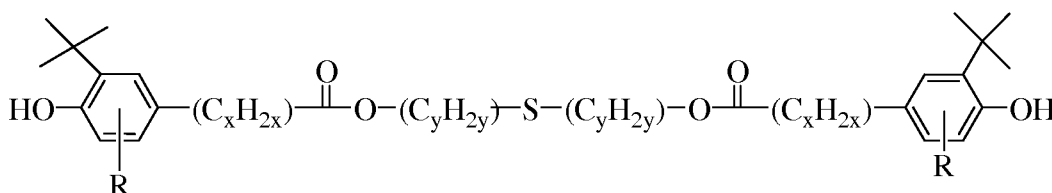

and wherein x is a number from 0 to 6, y is a number from 2 to 20 and R is a straight or branched chain alkyl radical having from 1 to 6 carbon atoms.

11. A lubricant composition as set forth in any one of claims 1-10 wherein said (B) at least one diphenylamine antioxidant is further defined as comprising at least one octylated/butylated diphenylamine antioxidant and also comprising thiodiethylene bis[3-(3,5-di-tert-butyl-4-hydroxyphenyl)propionate].

12. A lubricant composition as set forth in any one of claims 1-9 or 11 wherein said (B) at least one diphenylamine antioxidant is further defined as having the formula:

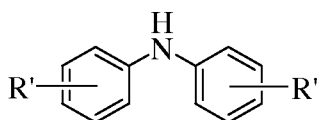

wherein each R' is independently a hydrogen atom, a straight or branched chain alkyl radical having from 1 to 18 carbon atoms, or an aralkyl radical having 7 to 14 carbon atoms;

wherein said (C) at least one antioxidant comprises said phenyl-alpha-naphthylamine antioxidant and said phenyl-alpha-naphthylamine antioxidant is further defined as having the formula:

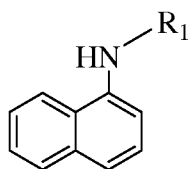

and wherein R₁ is an aryl radical having from 6 to 12 carbon atoms or an aryl radical having from 6 to 20 carbon atoms and substituted by one, two or three straight or branched chain alkyl radicals each having from 1 to 18 carbon atoms.

13. A lubricant composition as set forth in any one of claims 1, 2, 6-9, 11 or 12 wherein said (B) at least one diphenylamine antioxidant is further defined as comprising at least one octylated/butylated diphenylamine antioxidant, wherein said

(C) at least one antioxidant comprises said phenyl-alpha-naphthylamine antioxidant, and said phenyl-alpha-naphthylamine antioxidant is further defined as octylated phenyl-alpha-naphthylamine.

14. A lubricant composition as set forth in any one of claims 1-13 wherein said (B) at least one diphenylamine antioxidant and said (C) at least one antioxidant are present in a weight ratio of from about 9:1 to about 1:9 to each other, respectively.

15. A lubricant composition as set forth in any one of claims 1-14 wherein said (B) at least one diphenylamine antioxidant and said (C) at least one antioxidant are present in a combined amount of from about 0.3 to 7 parts by weight per 100 parts by weight of said base oil.

16. A lubricant composition as set forth in any one of claims 1-14 wherein said (B) at least one diphenylamine antioxidant and said (C) at least one antioxidant are present in a combined amount of from about 0.5 to 3 parts by weight per 100 parts by weight of said base oil.

17. A lubricant composition as set forth in any one of claims 1-14 further comprising a biodiesel fuel.

18. A lubricant composition as set forth in claim 17 wherein said biodiesel fuel is present in said lubricant composition in an amount of from 1 to 50 weight percent.

19. A lubricant composition as set forth in claim 17 wherein said biodiesel fuel comprises at least one fatty acid methyl ester of a vegetable or oleaginous seed oil.

20. A lubricant composition as set forth in claim 19 wherein fatty acid methyl ester is further defined as a soy oil fatty acid methyl ester, a rapeseed oil fatty acid methyl ester, a palm oil fatty acid methyl ester, or a coconut oil fatty acid methyl

ester.

21. A lubricant composition as set forth in any one of claims 17-20 wherein said biodiesel fuel is further defined as a first, second, or third generation biodiesel fuel.

22. A lubricant composition as set forth in any one of claims 1-21 wherein said base oil is further defined as an API Group II or Group III base oil.

23. A lubricant composition as set forth in any one of claims 1-10, 12-14, or 17-22 wherein said base oil is further defined as an API Group II base oil, said (B) at least one diphenylamine antioxidant is further defined as an octylated/butylated diphenylamine, and said (C) at least one antioxidant comprises octylated phenyl-alpha-naphthylamine, and (B) and (C) are present in a combined amount of from about 0.5 to 3 parts by weight per 100 parts by weight of said base oil

24. A lubricant composition as set forth in any one of claims 1-16 or 18-24 further comprising a biodiesel fuel in an amount of from 0.5 to 6 parts by weight per 100 parts by weight of said lubricant composition.

25. A lubricant composition as set forth in any one of claims 1-24 wherein the (A) base oil has an initial oxidation value measured according to ASTM D 6186 and wherein said lubricant composition has a final oxidation value measured according to ASTM D 6186 that is equal to or greater than the initial oxidation value of the (A) base oil when the composition is measured containing up to about 6 wt % of the biodiesel fuel.

26. A lubricant composition as set forth in claim 25 comprising from 0.3 to 7 parts by weight of said (B) and (C) antioxidants per 100 parts by weight of said lubricant composition.

27. A lubricant composition as set forth in claim 25 comprising from 0.9 to 3.5 parts by weight of said (B) and (C) antioxidants per 100 parts by weight of said lubricant composition.

28. A lubricant composition as set forth in claim 25 comprising less than about 2.1 parts by weight of said (B) and (C) antioxidants per 100 parts by weight of said lubricant composition.

29. A method of improving the performance of a lubricant composition suitable for use in diesel engines by improving resistance to degradation by oxidative by-products of a biodiesel fuel, wherein the lubricant composition comprises (A) a base oil, said method comprising the steps of:

- i. providing the (A) base oil;
- ii. providing (B) at least one diphenylamine antioxidant;
- iii. providing (C) at least one antioxidant selected from a sulfur containing phenolic antioxidant, a phenyl-alpha-naphthylamine antioxidant, and combinations thereof; and
- iv. combining (A), (B), and (C) to form the lubricant composition;

wherein the (A) base oil has an initial oxidation value measured according to ASTM D 6186, and

wherein the lubricant composition has a final oxidation value measured according to ASTM D 6186 that is equal to or greater than the initial oxidation value of the (A) base oil when the lubricant composition is measured containing up to about 6 wt % of the biodiesel fuel.

30. A method as set forth in claim 29 wherein the lubricant composition comprises from 0.3 to 7 parts by weight of the (B) and (C) antioxidants per 100 parts by weight of the lubricant composition.

31. A method as set forth in claim 29 wherein the lubricant composition comprises from 0.9 to 3.5 parts by weight of the (B) and (C) antioxidants per 100 parts by weight of the lubricant composition.

32. A method as set forth in claim 29 wherein the lubricant composition comprises less than about 2.1 parts by weight of the (B) and (C) antioxidants per 100 parts by weight of the lubricant composition.

33. A method as set forth in any one of claims 29-32 wherein the lubricant composition is diluted with the biodiesel fuel in a lubricant sump of a diesel engine.

34. A method as set forth in any one of claims 29-33 wherein the (C) at least one antioxidant comprises both the sulfur containing phenolic antioxidant and the phenyl-alpha-naphthylamine antioxidant.

35. A method as set forth in any one of claims 29-33 wherein the (C) at least one antioxidant comprises the sulfur containing phenolic antioxidant

36. A method as set forth in any one of claims 29-33 wherein the (C) at least one antioxidant comprises the phenyl-alpha-naphthylamine antioxidant.

37. A method as set forth in any one of claims 29-34 or 36 wherein the phenyl-alpha-naphthylamine antioxidant is further defined as having the formula:

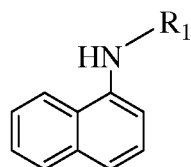

and wherein R_1 is an aryl radical having from 6 to 12 carbon atoms or an aryl radical having from 6 to 20 carbon atoms and substituted by one, two or three straight or branched chain alkyl radicals each having from 1 to 18 carbon atoms.

38. A method as set forth in any one of claims 29-35 wherein the (B) at least one diphenylamine antioxidant is further defined as having the formula:

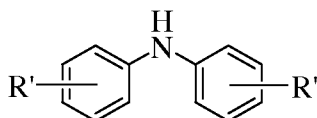

wherein each R' is independently a hydrogen atom, a straight or branched chain alkyl radical having from 1 to 18 carbon atoms, or an aralkyl radical having 7 to 14 carbon atoms;

wherein the (C) at least one antioxidant comprises the sulfur containing

phenolic antioxidant and the sulfur containing phenolic antioxidant is further defined as having the formula:

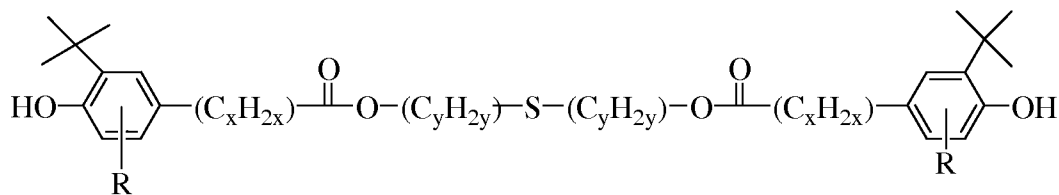

and wherein x is a number from 0 to 6, y is a number from 2 to 20 and R is a straight or branched chain alkyl radical having from 1 to 6 carbon atoms.

39. A method as set forth in any one of claims 29-34 wherein (B) at least one diphenylamine antioxidant is further defined as comprising at least one octylated/butylated diphenylamine antioxidant and also comprising thiodiethylene bis[3-(3,5-di-tert-butyl-4-hydroxyphenyl)propionate].

40. A method as set forth in any one of claims 29-34 wherein the (B) at least one diphenylamine antioxidant is further defined as having the formula:

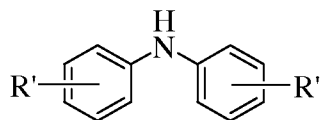

wherein each R' is independently a hydrogen atom, a straight or branched chain alkyl radical having from 1 to 18 carbon atoms, or an aralkyl radical having 7 to 14 carbon atoms;

wherein the (C) at least one antioxidant comprises the phenyl-alpha-naphthylamine antioxidant and the phenyl-alpha-naphthylamine antioxidant is further defined as having the formula:

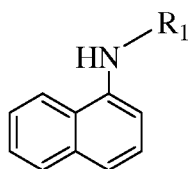

and wherein R₁ is an aryl radical having from 6 to 12 carbon atoms or an aryl radical having from 6 to 20 carbon atoms and substituted by one, two or three straight or branched chain alkyl radicals each having from 1 to 18 carbon atoms.

41. A method as set forth in any one of claims 29-34 wherein the (B) at least one diphenylamine antioxidant is further defined as comprising at least one octylated/butylated diphenylamine antioxidant, wherein the (C) at least one antioxidant comprises the phenyl-alpha-naphthylamine antioxidant, and the phenyl-alpha-naphthylamine antioxidant is further defined as octylated phenyl-alpha-naphthylamine.

42. A method as set forth in any one of claims 29-34 wherein base oil is further defined as an API Group II base oil, the (B) at least one diphenylamine antioxidant is further defined as an octylated/butylated diphenylamine, and the (C) at least one antioxidant comprises octylated phenyl-alpha-naphthylamine, and (B) and (C) are present in a combined amount of from about 0.5 to 3 parts by weight per 100 parts by weight of the base oil.

AMENDED CLAIMS

received by the International Bureau on 10 January 2011 (10.01.2011)

1. A lubricant composition suitable for use in a diesel engine and resistant to degradation by oxidative by-products of biodiesel fuel, said composition comprising:

- A. a base oil;
- B. at least one diphenylamine antioxidant; and
- C. both a sulfur containing phenolic antioxidant and a phenyl-alpha-naphthylamine antioxidant;

wherein said phenyl-alpha-naphthylamine antioxidant is further defined as having the formula:

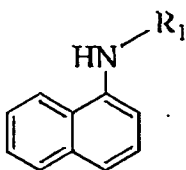

wherein R₁ is an aryl radical having from 6 to 12 carbon atoms or an aryl radical having from 6 to 20 carbon atoms and substituted by one, two or three straight or branched chain alkyl radicals each having from 1 to 18 carbon atoms; and

wherein said sulfur containing phenolic antioxidant is further defined as having the formula:

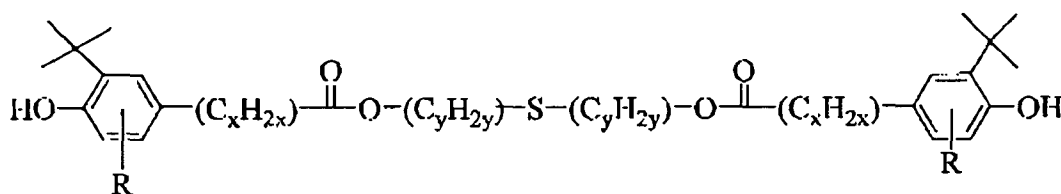

wherein x is a number from 0 to 6, y is a number from 2 to 20 and R is a straight or branched chain alkyl radical having from 1 to 6 carbon atoms.

2. (Cancelled)
3. (Cancelled)
4. (Cancelled)
5. (Cancelled)
6. (Cancelled)
7. (Cancelled)
8. (Cancelled)
9. (Cancelled)
10. (Cancelled)
11. (Cancelled)
12. (Cancelled)

13. A lubricant composition suitable for use in a diesel engine and resistant to degradation by oxidative by-products of biodiesel fuel, said composition comprising:

- A. a base oil;
- B. at least one diphenylamine antioxidant comprising an octylated/butylated diphenylamine antioxidant; and
- C. at least one antioxidant comprising octylated phenyl-alpha-naphthylamine.

14. A lubricant composition as set forth in any one of claims 1 or 13 wherein said (B) at least one diphenylamine antioxidant and said (C) at least one antioxidant are present in a weight ratio of from about 9:1 to about 1:9 to each other, respectively.

15. A lubricant composition as set forth in any one of claims 1 or 13-14 wherein said (B) at least one diphenylamine antioxidant and said (C) at least one antioxidant are present in a

combined amount of from about 0.3 to 7 parts by weight per 100 parts by weight of said base oil.

16. A lubricant composition as set forth in any one of claims 1 or 13-14 wherein said (B) at least one diphenylamine antioxidant and said (C) at least one antioxidant are present in a combined amount of from about 0.5 to 3 parts by weight per 100 parts by weight of said base oil.

17. A lubricant composition as set forth in any one of claims 1 or 13-14 further comprising a biodiesel fuel.

18. A lubricant composition as set forth in claim 17 wherein said biodiesel fuel is present in said lubricant composition in an amount of from 1 to 50 weight percent.

19. A lubricant composition as set forth in claim 17 wherein said biodiesel fuel comprises at least one fatty acid methyl ester of a vegetable or oleaginous seed oil.

20. A lubricant composition as set forth in claim 19 wherein fatty acid methyl ester is further defined as a soy oil fatty acid methyl ester, a rapeseed oil fatty acid methyl ester, a palm oil fatty acid methyl ester, or a coconut oil fatty acid methyl ester.

21. A lubricant composition as set forth in any one of claims 17-20 wherein said biodiesel fuel is further defined as a first, second, or third generation biodiesel fuel.

22. A lubricant composition as set forth in any one of claims 1 or 13-21 wherein said base oil is further defined as an API Group II or Group III base oil.

23. A lubricant composition as set forth in any one of claims 1, 13, 14, or 17-22 wherein said base oil is further defined as an API Group II base oil, and (B) and (C) are present in a combined amount of from about 0.5 to 3 parts by weight per 100 parts by weight of said base oil

24. A lubricant composition as set forth in any one of claims 1, 13-16 or 18-23 further

comprising a biodiesel fuel in an amount of from 0.5 to 6 parts by weight per 100 parts by weight of said lubricant composition.

25. A lubricant composition as set forth in any one of claims 1 or 13-24 wherein said (A) base oil has an initial oxidation value measured according to ASTM D 6186 and wherein said lubricant composition has a final oxidation value measured according to ASTM D 6186 that is equal to or greater than the initial oxidation value of said (A) base oil when said composition is measured containing up to about 6 wt % of the biodiesel fuel.

26. A lubricant composition as set forth in claim 25 comprising from 0.3 to 7 parts by weight of said (B) and (C) antioxidants per 100 parts by weight of said lubricant composition.

27. A lubricant composition as set forth in claim 25 comprising from 0.9 to 3.5 parts by weight of said (B) and (C) antioxidants per 100 parts by weight of said lubricant composition.

28. A lubricant composition as set forth in claim 25 comprising less than about 2.1 parts by weight of said (B) and (C) antioxidants per 100 parts by weight of said lubricant composition.

29. A method of improving the performance of a lubricant composition suitable for use in diesel engines by improving resistance to degradation by oxidative by-products of a biodiesel fuel, wherein the lubricant composition comprises (A) a base oil, said method comprising the steps of:

- i. providing the (A) base oil;
- ii. providing (B) at least one diphenylamine antioxidant;
- iii. providing (C) at least one antioxidant selected from a sulfur containing phenolic antioxidant, a phenyl-alpha-naphthylamine antioxidant, and combinations thereof; and
- iv. combining (A), (B), and (C) to form the lubricant composition;

wherein the (A) base oil has an initial oxidation value measured according to ASTM D 6186, and

wherein the lubricant composition has a final oxidation value measured according to ASTM D 6186 that is equal to or greater than the initial oxidation value of the (A) base oil when the lubricant composition is measured containing up to about 6 wt % of the biodiesel fuel.

30. A method as set forth in claim 29 wherein the lubricant composition comprises from 0.3 to 7 parts by weight of the (B) and (C) antioxidants per 100 parts by weight of the lubricant composition.

31. A method as set forth in claim 29 wherein the lubricant composition comprises from 0.9 to 3.5 parts by weight of the (B) and (C) antioxidants per 100 parts by weight of the lubricant composition.

32. A method as set forth in claim 29 wherein the lubricant composition comprises less than about 2.1 parts by weight of the (B) and (C) antioxidants per 100 parts by weight of the

lubricant composition.

33. A method as set forth in any one of claims 29-32 wherein the lubricant composition is diluted with the biodiesel fuel in a lubricant sump of a diesel engine.

34. A method as set forth in any one of claims 29-33 wherein the (C) at least one antioxidant comprises both the sulfur containing phenolic antioxidant and the phenyl-alpha-naphthylamine antioxidant.

35. A method as set forth in any one of claims 29-33 wherein the (C) at least one antioxidant comprises the sulfur containing phenolic antioxidant

36. A method as set forth in any one of claims 29-33 wherein the (C) at least one antioxidant comprises the phenyl-alpha-naphthylamine antioxidant.

37. A method as set forth in any one of claims 29-34 or 36 wherein the phenyl-alpha-naphthylamine antioxidant is further defined as having the formula:

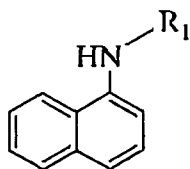

and wherein R₁ is an aryl radical having from 6 to 12 carbon atoms or an aryl radical having from 6 to 20 carbon atoms and substituted by one, two or three straight or branched chain alkyl radicals each having from 1 to 18 carbon atoms.

38. A method as set forth in any one of claims 29-35 wherein the (B) at least one diphenylamine antioxidant is further defined as having the formula:

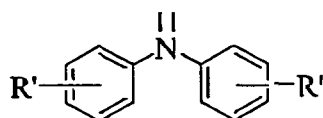

wherein each R' is independently a hydrogen atom, a straight or branched chain alkyl radical having from 1 to 18 carbon atoms, or an aralkyl radical having 7 to 14 carbon atoms;

wherein the (C) at least one antioxidant comprises the sulfur containing phenolic antioxidant and the sulfur containing phenolic antioxidant is further defined as having the formula:

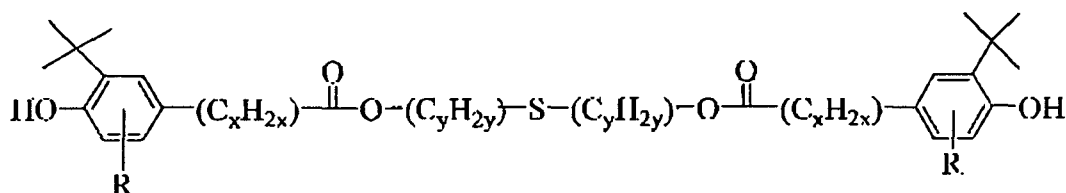

and wherein x is a number from 0 to 6, y is a number from 2 to 20 and R is a straight or branched chain alkyl radical having from 1 to 6 carbon atoms.

39. A method as set forth in any one of claims 29-34 wherein (B) at least one diphenylamine antioxidant is further defined as comprising at least one octylated/butylated diphenylamine antioxidant and also comprising thiodiethylene bis[3-(3,5-di-tert-butyl-4-hydroxyphenyl)propionate].

40. A method as set forth in any one of claims 29-34 wherein the (B) at least one diphenylamine antioxidant is further defined as having the formula:

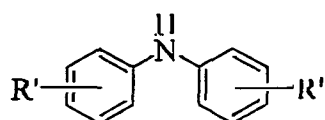

wherein each R' is independently a hydrogen atom, a straight or branched chain alkyl radical having from 1 to 18 carbon atoms, or an aralkyl radical having 7 to 14 carbon atoms;

wherein the (C) at least one antioxidant comprises the phenyl-alpha-naphthylamine antioxidant and the phenyl-alpha-naphthylamine antioxidant is further defined as having the

formula:

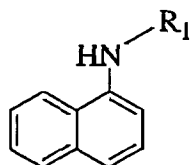

and wherein R_1 is an aryl radical having from 6 to 12 carbon atoms or an aryl radical having from 6 to 20 carbon atoms and substituted by one, two or three straight or branched chain alkyl radicals each having from 1 to 18 carbon atoms.

41. A method as set forth in any one of claims 29-34 wherein the (B) at least one diphenylamine antioxidant is further defined as comprising at least one octylated/butylated diphenylamine antioxidant, wherein the (C) at least one antioxidant comprises the phenyl-alpha-naphthylamine antioxidant, and the phenyl-alpha-naphthylamine antioxidant is further defined as octylated phenyl-alpha-naphthylamine.

42. A method as set forth in any one of claims 29-34 wherein base oil is further defined as an API Group II base oil, the (B) at least one diphenylamine antioxidant is further defined as an octylated/butylated diphenylamine, and the (C) at least one antioxidant comprises octylated phenyl-alpha-naphthylamine, and (B) and (C) are present in a combined amount of from about 0.5 to 3 parts by weight per 100 parts by weight of the base oil.

STATEMENT UNDER ARTICLE 19 (1)

Claims 1 is amended to recite and further define both the sulfur containing phenolic antioxidant and the phenyl-alpha-naphthylamine antioxidant. Support for currently amended claim 1 can be found at least in original claims 2, 9 and 10, as well as paragraphs [0038], [0040] and [0046] of the subject application as filed. In view of the amendment of claim 1, claims 2-12 are cancelled. Claim 13 is amended such that this claim is in independent form including all the elements of original claim 13. Claims 14-17 and 22-25 are amended accordingly for purposes of proper claim dependency. Accordingly, no new matter is added.

Item V of Written Opinion:

Relative to (D1)-(D4), none of these references disclose, teach, or even suggest all of the claimed features of amended independent claims 1 or 13, or all of the claimed features of original independent claim 29, either individually or in combination. For example, in considering independent claim 1, (D1)-(D4) fail to disclose, teach, or even suggest a lubricant composition including the instantly claimed sulfur containing phenolic antioxidant in combination with the instantly claimed phenyl-alpha-naphthylamine antioxidant. Relative to amended independent claim 13, (D1)-(D4) fail to disclose, teach, or even suggest a lubricant composition including an octylated/butylated diphenylamine antioxidant and an octylated phenyl-alpha-naphthylamine, or the excellent physical properties obtained from such a lubricant composition. Finally, with respect to independent claim 29, (D1)-(D4) fail to disclose, teach, or even suggest a method of improving the performance of a lubricant composition comprising the recited components in which the lubricant composition has a final oxidation value measured according to ASTM D 6186 that is equal to or greater than an initial oxidation value of a base oil. For this reason, the

Applicants submit that amended claims 1, 13, as well as original claim 29, and all claims which depend from these independent claims, are novel and involve an inventive step.

The Applicant submits that the claims are all linked to form a single general inventive concept, are clear and unambiguous, and are both novel and involve an inventive step. Further and favorable reconsideration of the subject application is hereby requested.

**High Pressure DSC (ASTM D 6186, Isothermal @ 200°C)
2% aged Soy Methyl Ester**

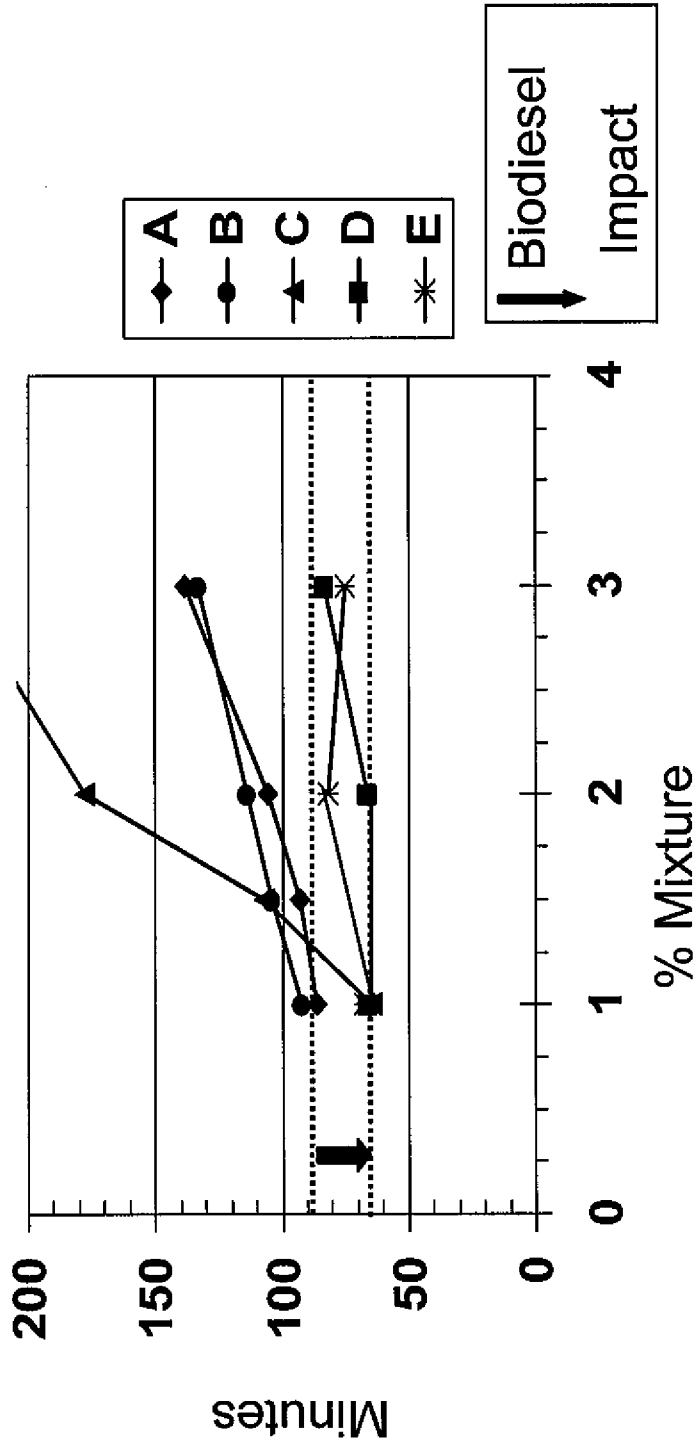

Figure 1

**High Pressure DSC (ASTM D 6186, Isothermal @ 200°C)
2% aged Rapeseed Methyl Ester**

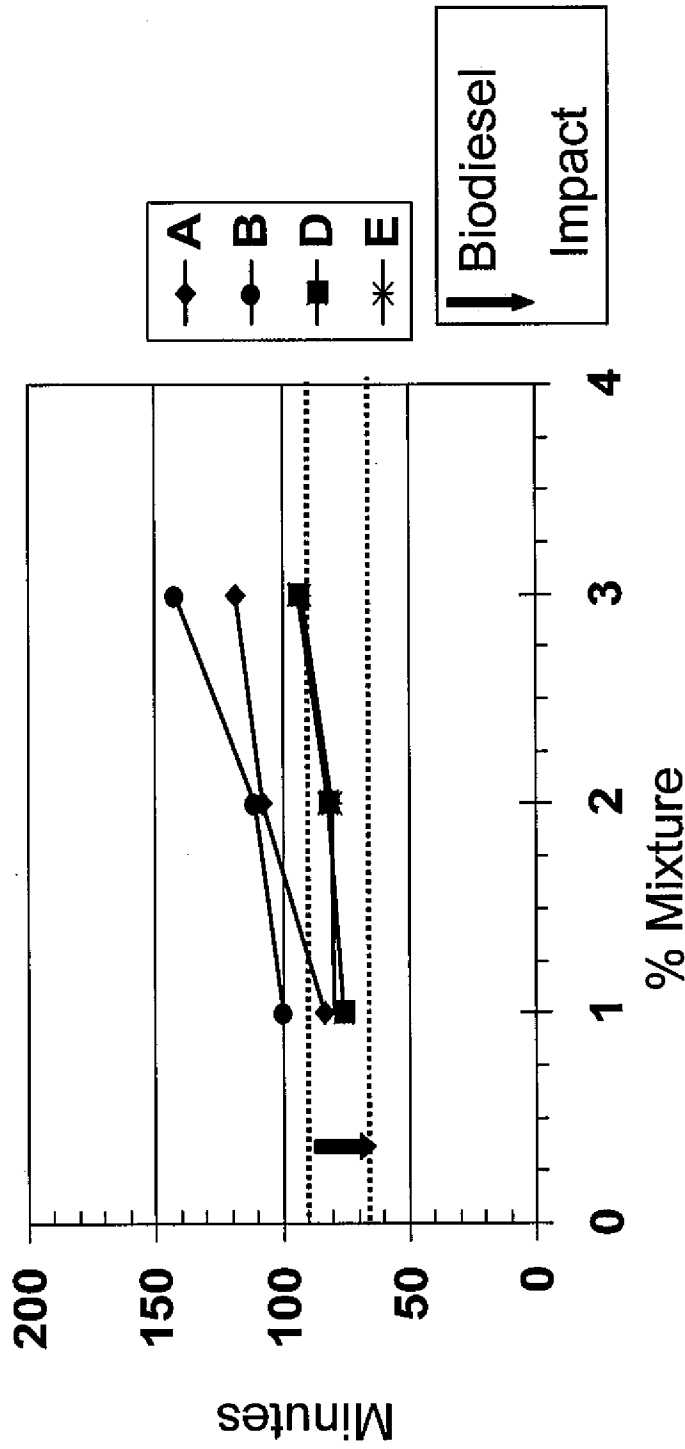

Figure 2

**High Pressure DSC (ASTM D 6186, Isothermal @ 200°C)
2% aged Palm Methyl Ester**

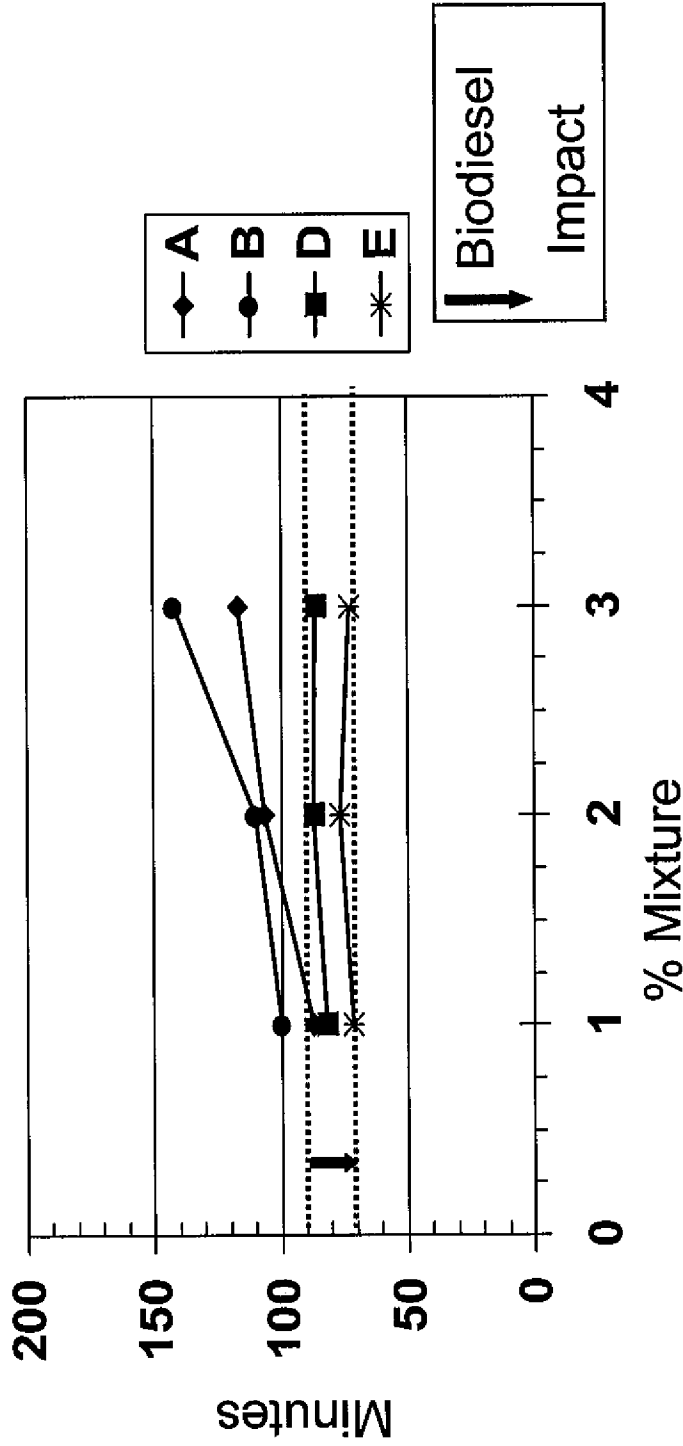

Figure 3

High Pressure DSC (ASTM D 6186, Isothermal @ 200°C)

2% aged Coconut Methyl Ester

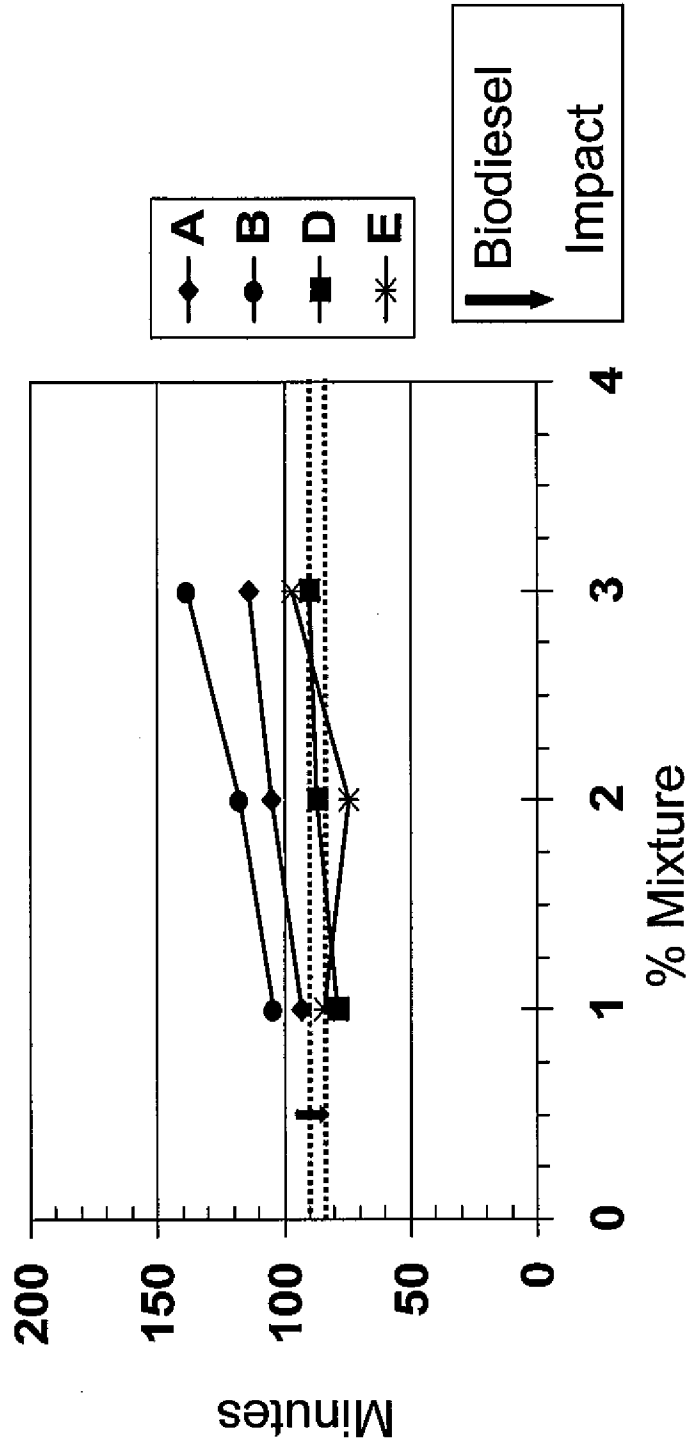

Figure 4

**High Pressure DSC (ASTM D 6186, Isothermal @ 200°C)
6% aged Soy Methyl Ester**

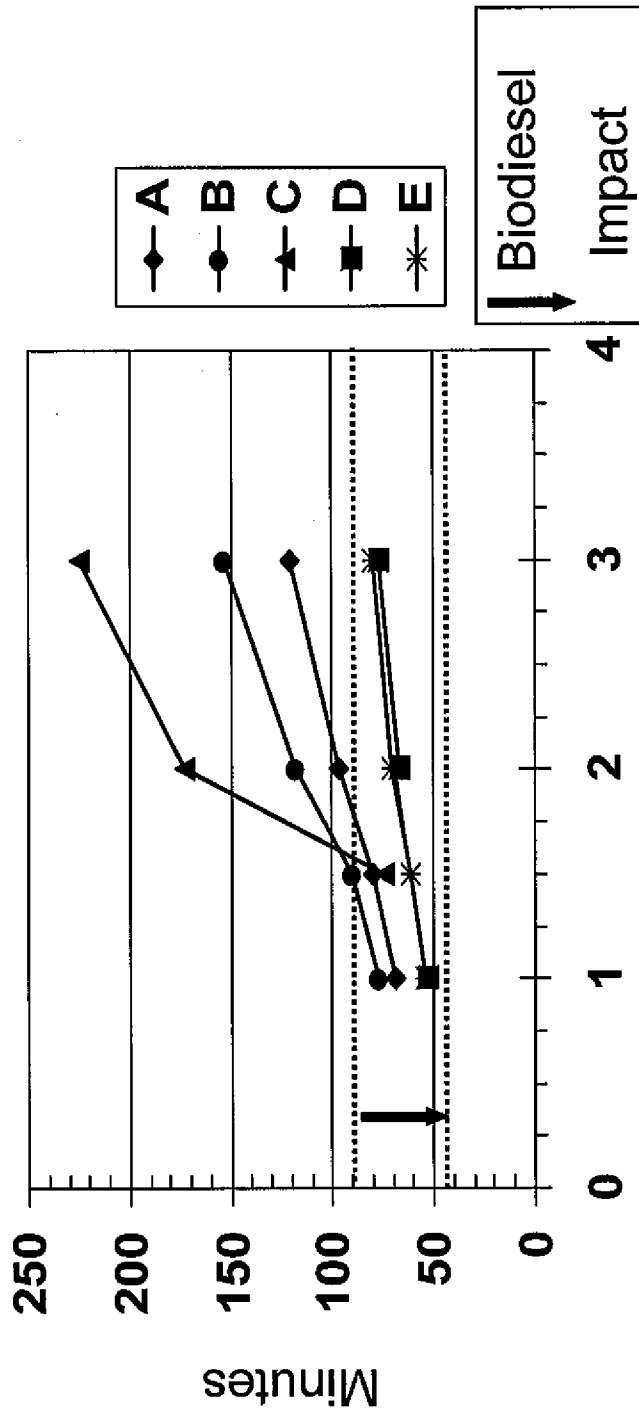

Figure 5

**High Pressure DSC (ASTM D 6186, Isothermal @ 200°C)
6% aged Rapeseed Methyl Ester**

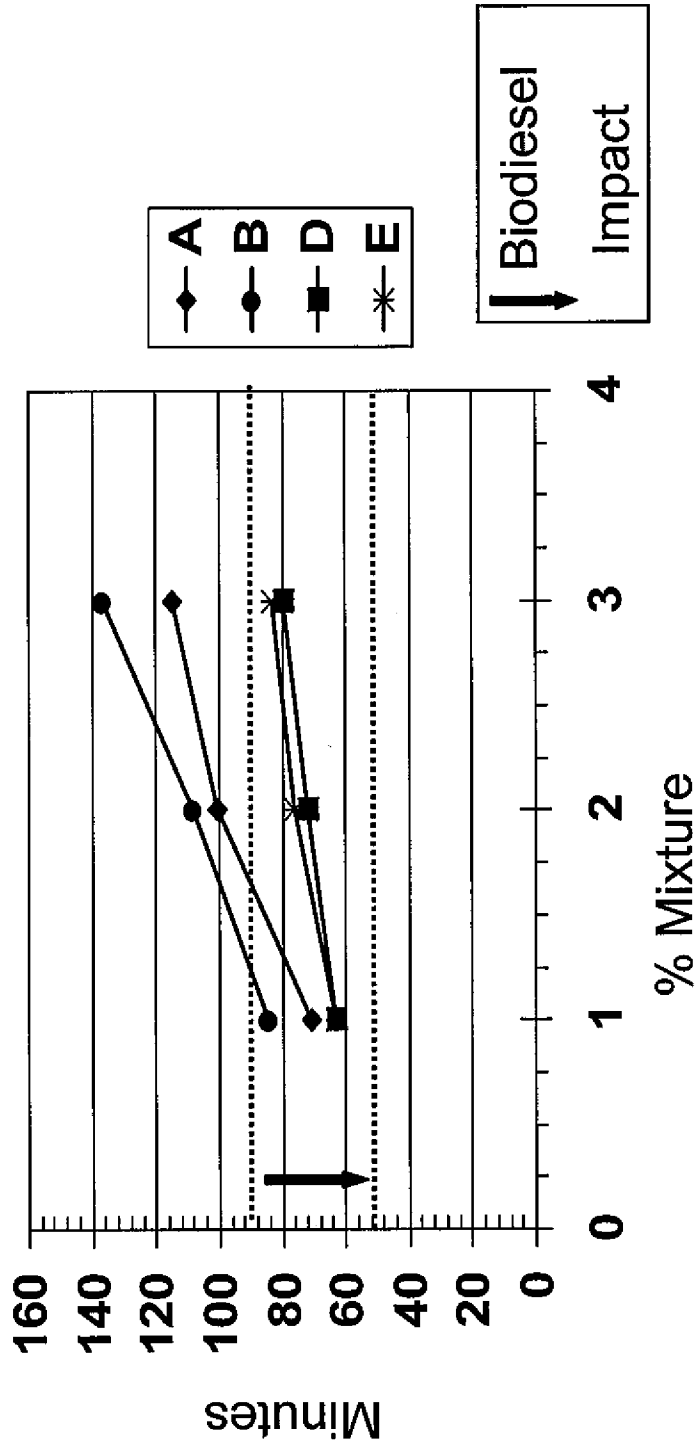

Figure 6

**High Pressure DSC (ASTM D 6186, Isothermal @ 200°C)
6% aged Palm Methyl Ester**

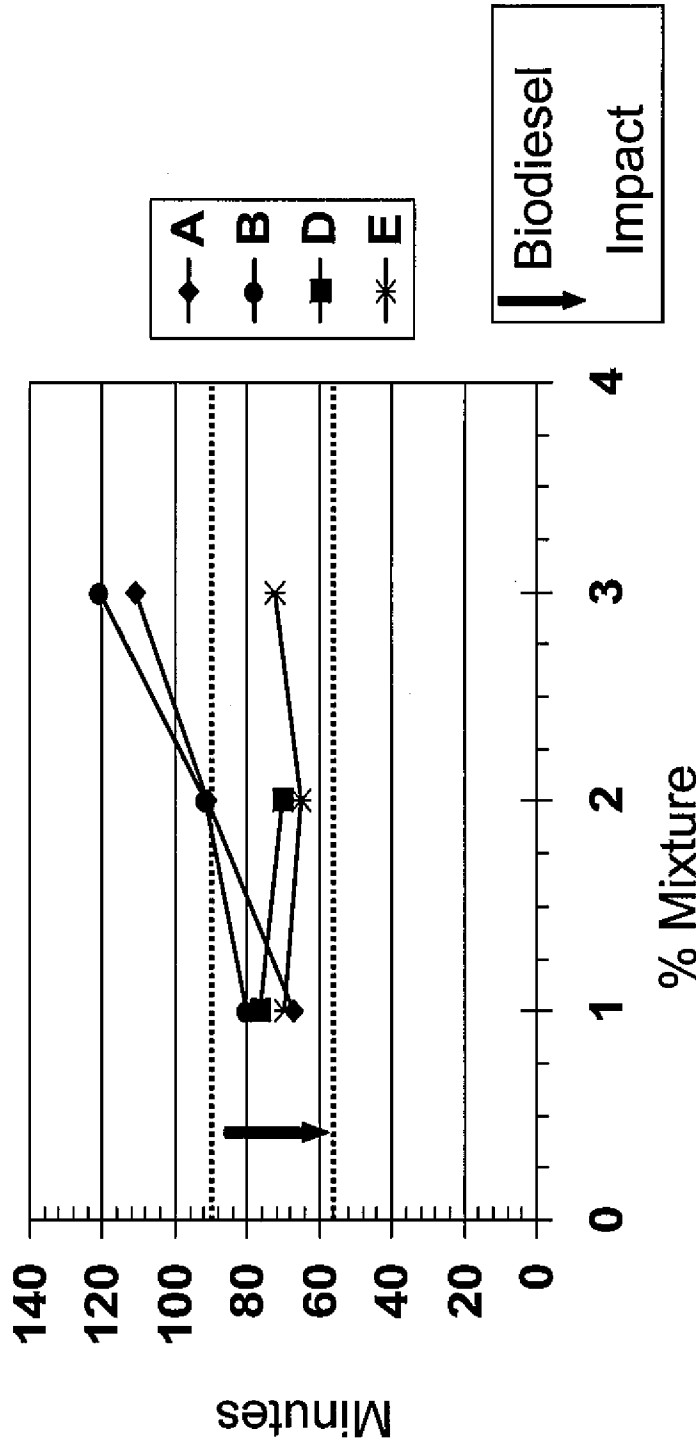

Figure 7

**High Pressure DSC (ASTM D 6186, Isothermal @ 200°C)
6% aged Coconut Methyl Ester**

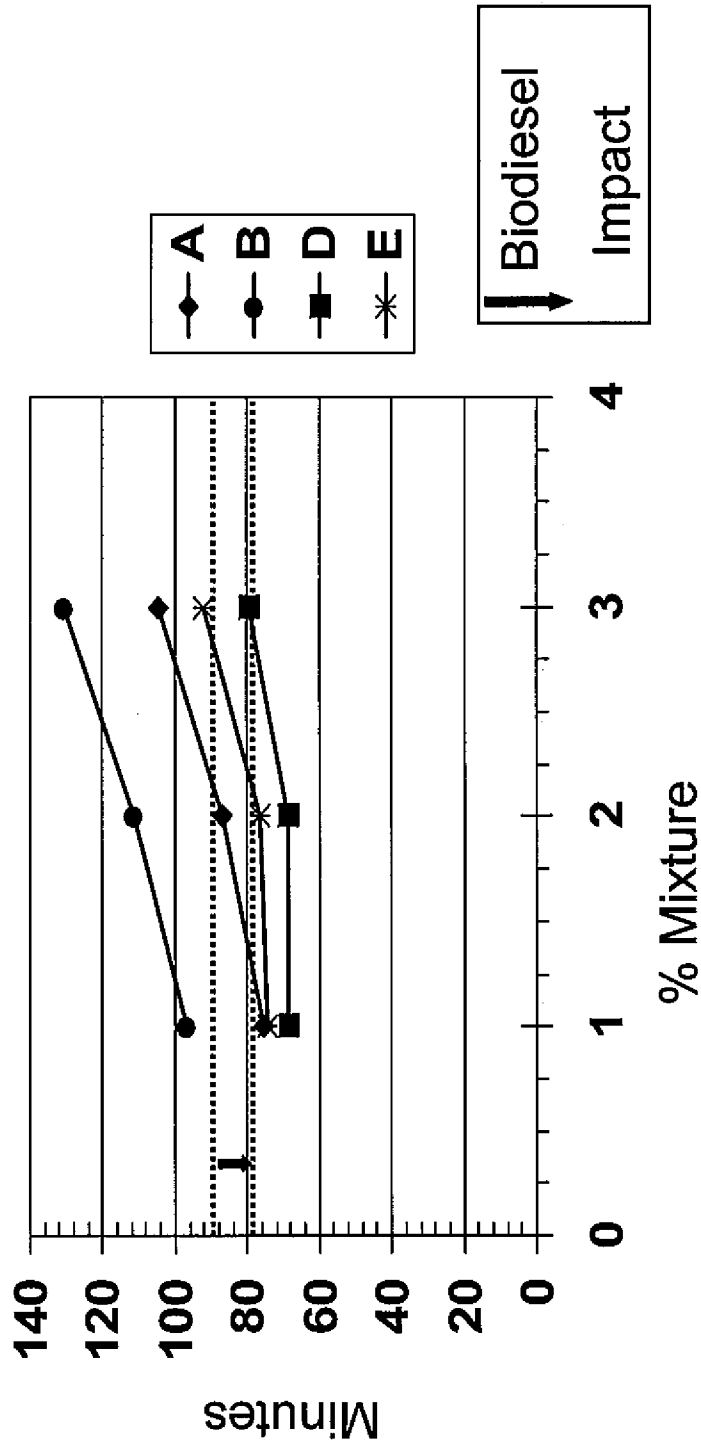

Figure 8

Viscosity Increase Test (SAE 040793 @ 160°C)

2% aged Soy Methyl Ester

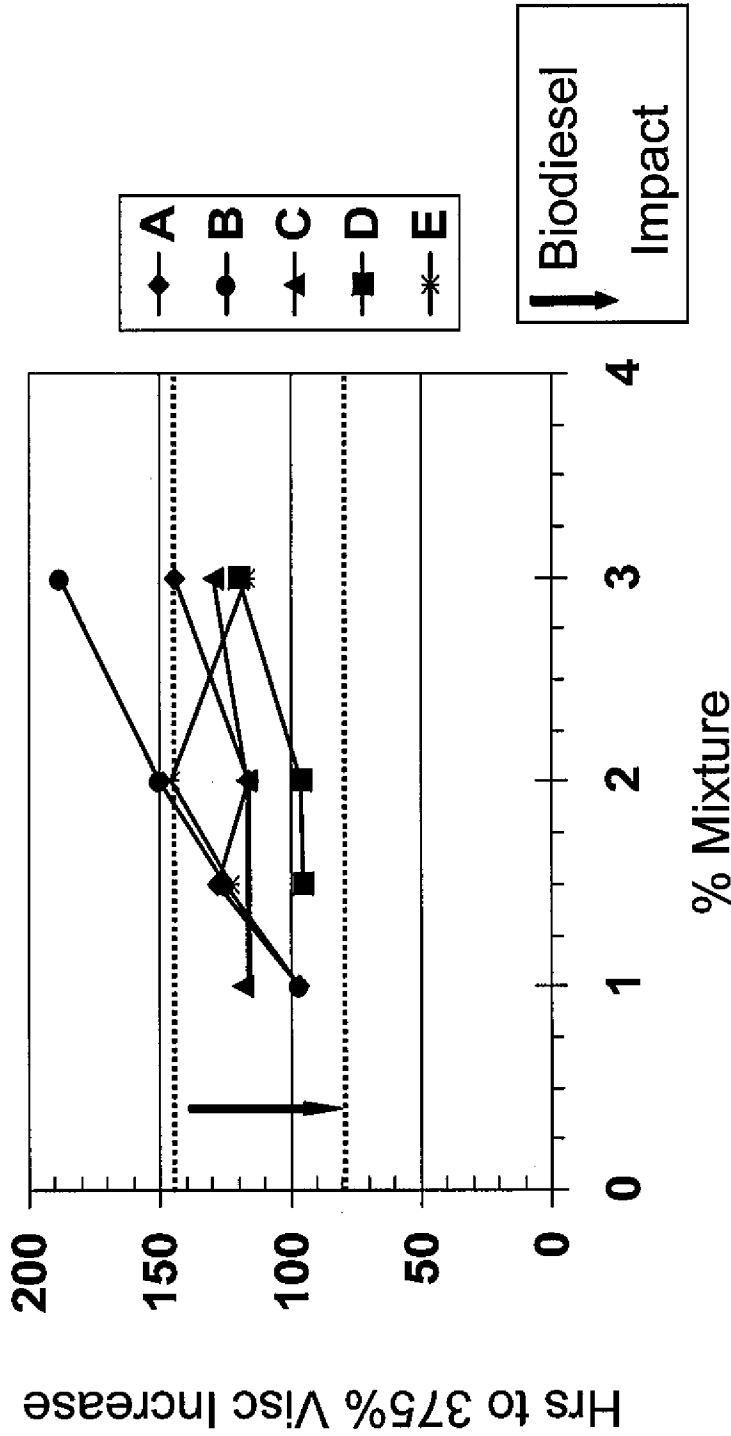

Figure 9

Viscosity Increase Test (SAE 040793 @ 160°C)
2% aged Rapeseed Methyl Ester

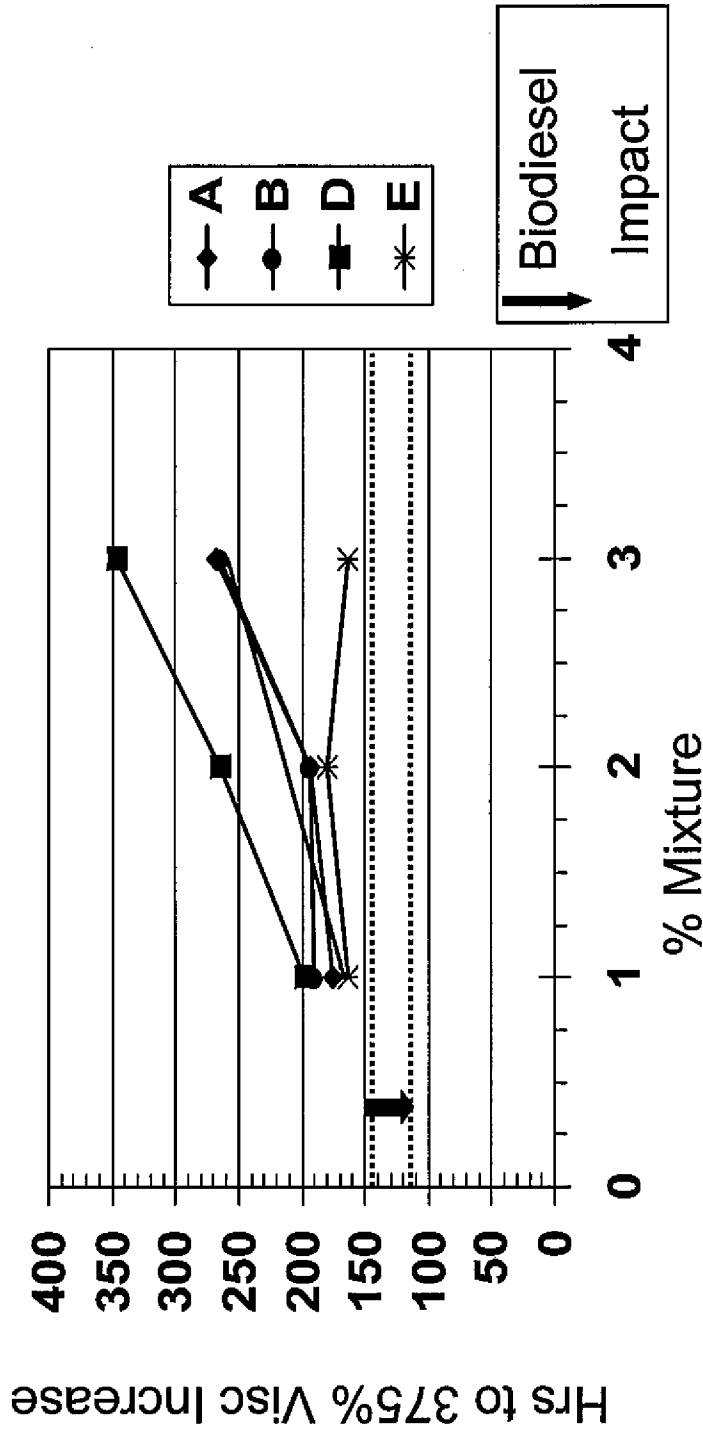

Figure 10

**Viscosity Increase Test (SAE 040793 @ 160°C)
2% aged Palm Methyl Ester**

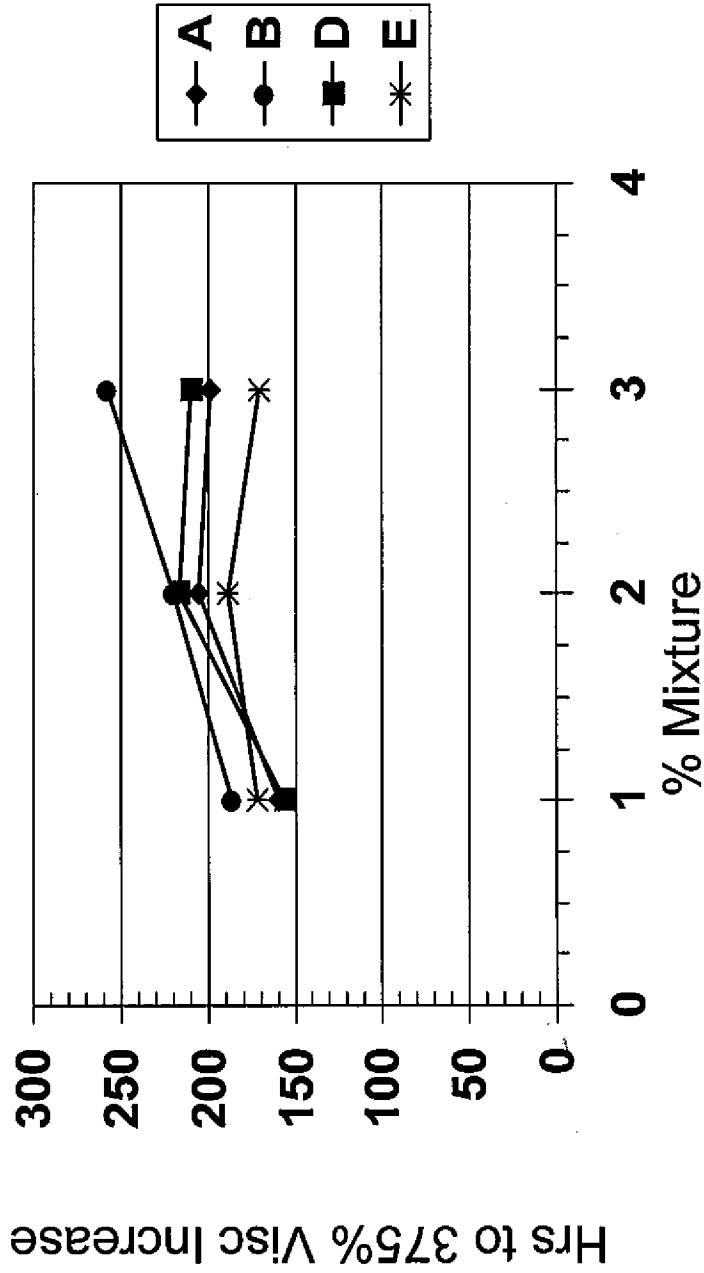

Figure 11

Viscosity Increase Test (SAE 040793 @ 160°C)
2% aged Coconut Methyl Ester

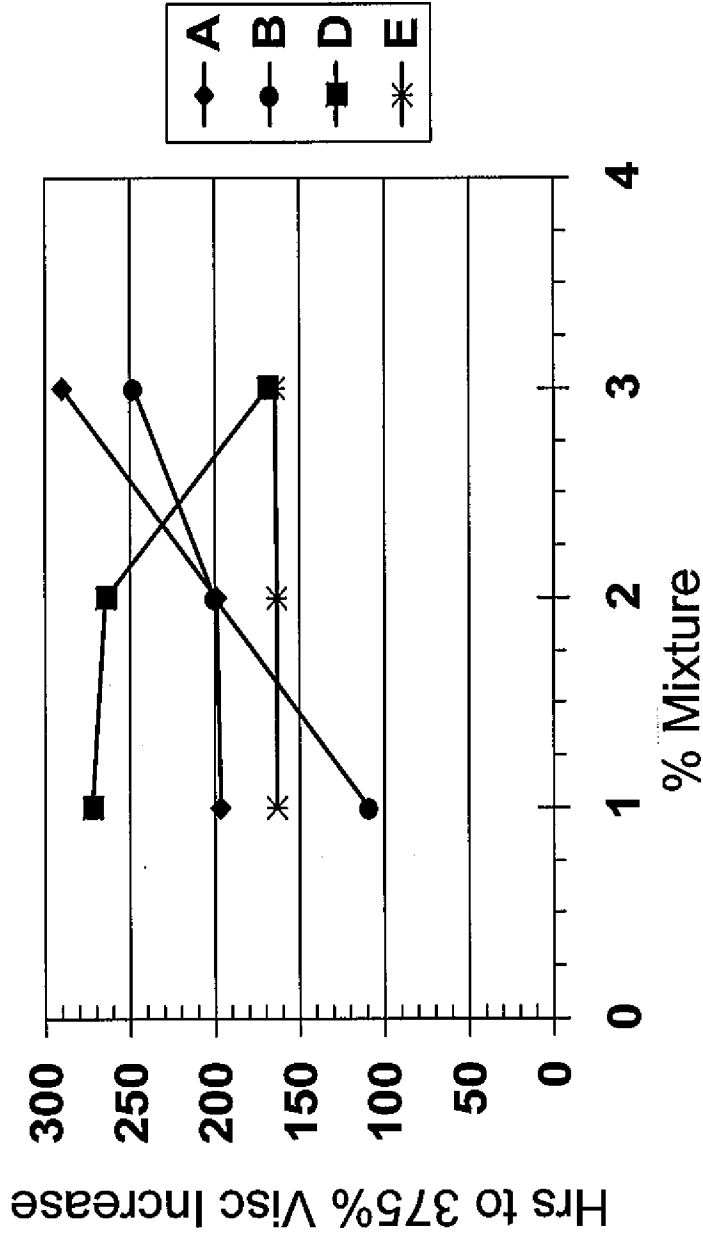

Figure 12

Viscosity Increase Test (SAE 040793 @ 160°C)
6% aged Soy Methyl Ester

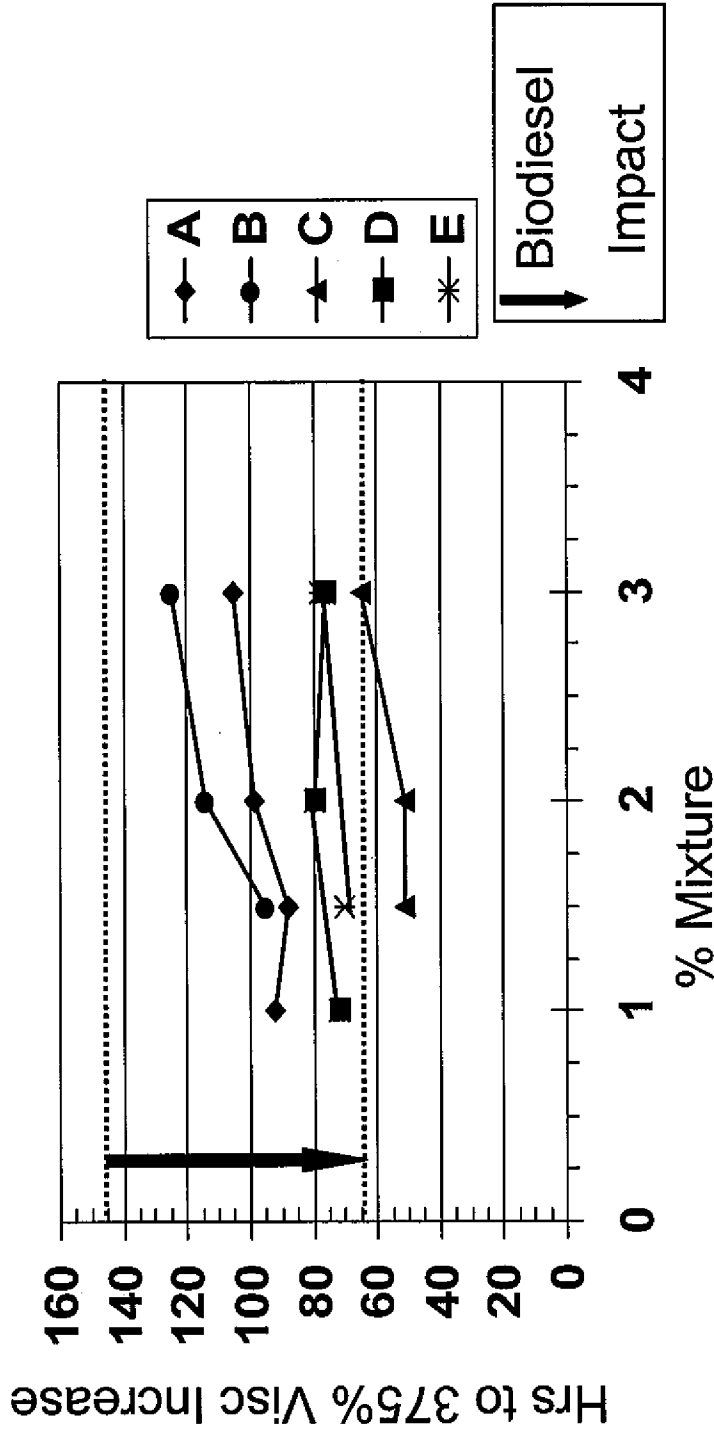

Figure 13

Viscosity Increase Test (SAE 040793 @ 160°C)
6% aged Rapeseed Methyl Ester

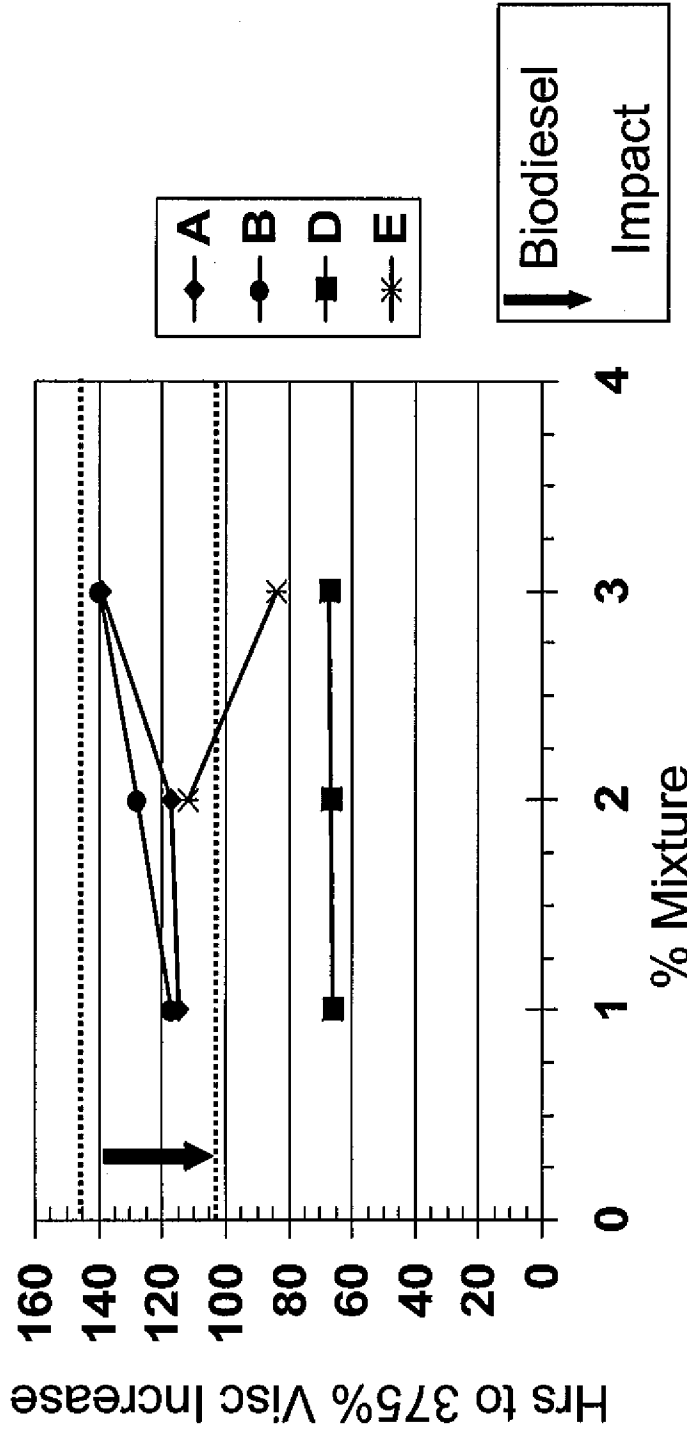

Figure 14

Viscosity Increase Test (SAE 040793 @ 160°C)
6% aged Palm Methyl Ester

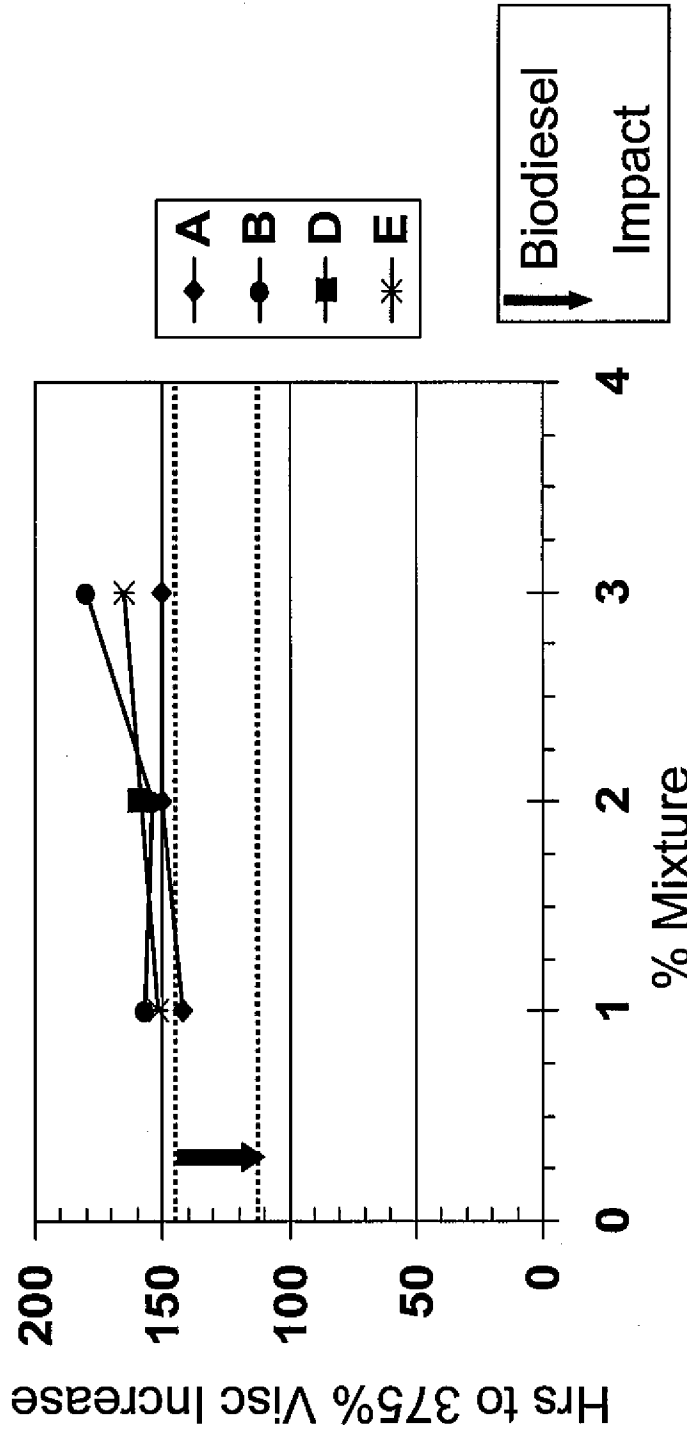

Figure 15

Viscosity Increase Test (SAE 040793 @ 160°C)
6% aged Coconut Methyl Ester

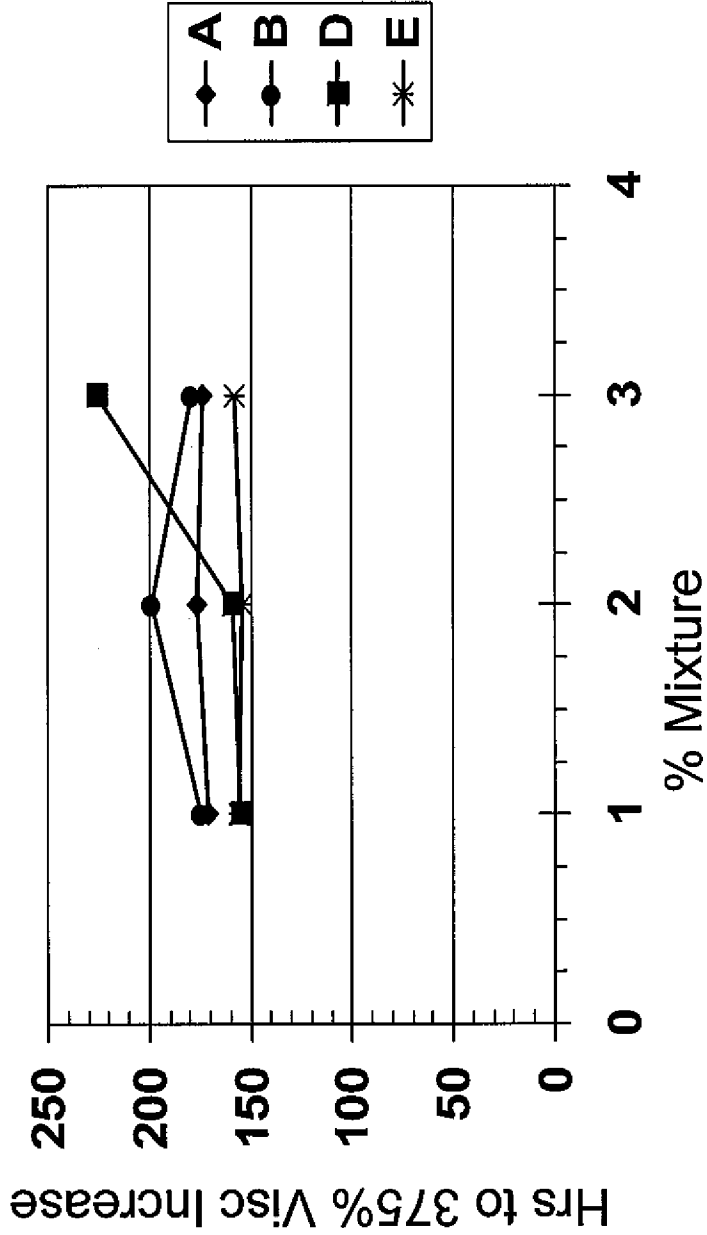

Figure 16

INTERNATIONAL SEARCH REPORT

International application No
PCT/US2010/044601

A. CLASSIFICATION OF SUBJECT MATTER
 INV. C10M133/12 C10M141/08
 ADD. C10N30/10 C10N40/04

According to International Patent Classification (IPC) or to both national classification and IPC

B. FIELDS SEARCHED

Minimum documentation searched (classification system followed by classification symbols)
 C10M

Documentation searched other than minimum documentation to the extent that such documents are included in the fields searched

Electronic data base consulted during the international search (name of data base and, where practical, search terms used)

EPO-Internal, COMPENDEX, WPI Data

C. DOCUMENTS CONSIDERED TO BE RELEVANT

Category*	Citation of document, with indication, where appropriate, of the relevant passages	Relevant to claim No.
X	EP 1 006 173 A1 (ETHYL PETROLEUM ADDITIVES LTD [GB]) 7 June 2000 (2000-06-07) paragraph [0006] paragraph [0025] - paragraph [0026] claims; examples	1-3,6-9, 14,15, 22,25-28
X	EP 0 716 141 A2 (NIPPON OIL CO LTD [JP] NIPPON OIL CO LTD) 12 June 1996 (1996-06-12) page 3, line 32 - page 3, line 23 page 5, line 51 - page 7, line 8 claims; examples	1,6-9, 12-16, 22,23, 25-28
	----- -/--	

Further documents are listed in the continuation of Box C.

See patent family annex.

* Special categories of cited documents :

- "A" document defining the general state of the art which is not considered to be of particular relevance
- "E" earlier document but published on or after the international filing date
- "L" document which may throw doubts on priority claim(s) or which is cited to establish the publication date of another citation or other special reason (as specified)
- "O" document referring to an oral disclosure, use, exhibition or other means
- "P" document published prior to the international filing date but later than the priority date claimed

- "T" later document published after the international filing date or priority date and not in conflict with the application but cited to understand the principle or theory underlying the invention
- "X" document of particular relevance; the claimed invention cannot be considered novel or cannot be considered to involve an inventive step when the document is taken alone
- "Y" document of particular relevance; the claimed invention cannot be considered to involve an inventive step when the document is combined with one or more other such documents, such combination being obvious to a person skilled in the art.
- "&" document member of the same patent family

Date of the actual completion of the international search

Date of mailing of the international search report

2 November 2010

10/11/2010

Name and mailing address of the ISA/

European Patent Office, P.B. 5818 Patentlaan 2
 NL - 2280 HV Rijswijk
 Tel. (+31-70) 340-2040,
 Fax: (+31-70) 340-3016

Authorized officer

Elflein, Eleonore

INTERNATIONAL SEARCH REPORT

International application No
PCT/US2010/044601

C(Continuation). DOCUMENTS CONSIDERED TO BE RELEVANT

Category*	Citation of document, with indication, where appropriate, of the relevant passages	Relevant to claim No.
X	US 2007/203035 A1 (DONG JUN [US] ET AL) 30 August 2007 (2007-08-30) paragraph [0021] - paragraph [0032] paragraph [0041] - paragraph [0043] claims; examples -----	1-5, 10, 11, 14-16, 22, 25-28
X	WO 2009/013275 A1 (SHELL INT RESEARCH [NL]; SHINODA NORIAKI [JP]; NAGATOMI EIJI [JP]) 29 January 2009 (2009-01-29) page 2, line 13 - page 3, line 8 page 4, line 14 - page 6, line 22 claims; examples -----	1, 3-5, 15, 17-22, 24-42

INTERNATIONAL SEARCH REPORT

Information on patent family members

International application No

PCT/US2010/044601

Patent document cited in search report	Publication date	Patent family member(s)	Publication date	
EP 1006173	A1	07-06-2000	AU 5936499 A	01-06-2000
			BR 9905759 A	15-08-2000
			CA 2287726 A1	30-05-2000
			CN 1255533 A	07-06-2000
			JP 2000160182 A	13-06-2000
			KR 20000035777 A	26-06-2000
			SG 77271 A1	19-12-2000
EP 0716141	A2	12-06-1996	CN 1132782 A	09-10-1996
			JP 3401349 B2	28-04-2003
			JP 8157848 A	18-06-1996
			US 5658866 A	19-08-1997
US 2007203035	A1	30-08-2007	EP 2041249 A2	01-04-2009
			RU 2008138709 A	10-04-2010
			WO 2007100726 A2	07-09-2007
WO 2009013275	A1	29-01-2009	AR 068609 A1	25-11-2009
			CN 101796171 A	04-08-2010
			EP 2179011 A1	28-04-2010
			JP 2009024123 A	05-02-2009
			US 2010269774 A1	28-10-2010