



Europäisches Patentamt  
 European Patent Office  
 Office européen des brevets



(11) **EP 1 609 728 A2**

(12) **EUROPEAN PATENT APPLICATION**

(43) Date of publication:  
**28.12.2005 Bulletin 2005/52**

(51) Int Cl.7: **B65D 6/20**

(21) Application number: **05100548.6**

(22) Date of filing: **27.01.2005**

(84) Designated Contracting States:  
**AT BE BG CH CY CZ DE DK EE ES FI FR GB GR  
 HU IE IS IT LI LT LU MC NL PL PT RO SE SI SK TR**  
 Designated Extension States:  
**AL BA HR LV MK YU**

(72) Inventor: **FRETI, Giuseppe**  
**24069, LUZZANA (Bergamo) (IT)**

(74) Representative: **Crippa, Paolo Ernesto**  
**JACOBACCI & PARTNERS S.p.A.**  
**Piazzale Arnaldo, 2**  
**25121 Brescia (IT)**

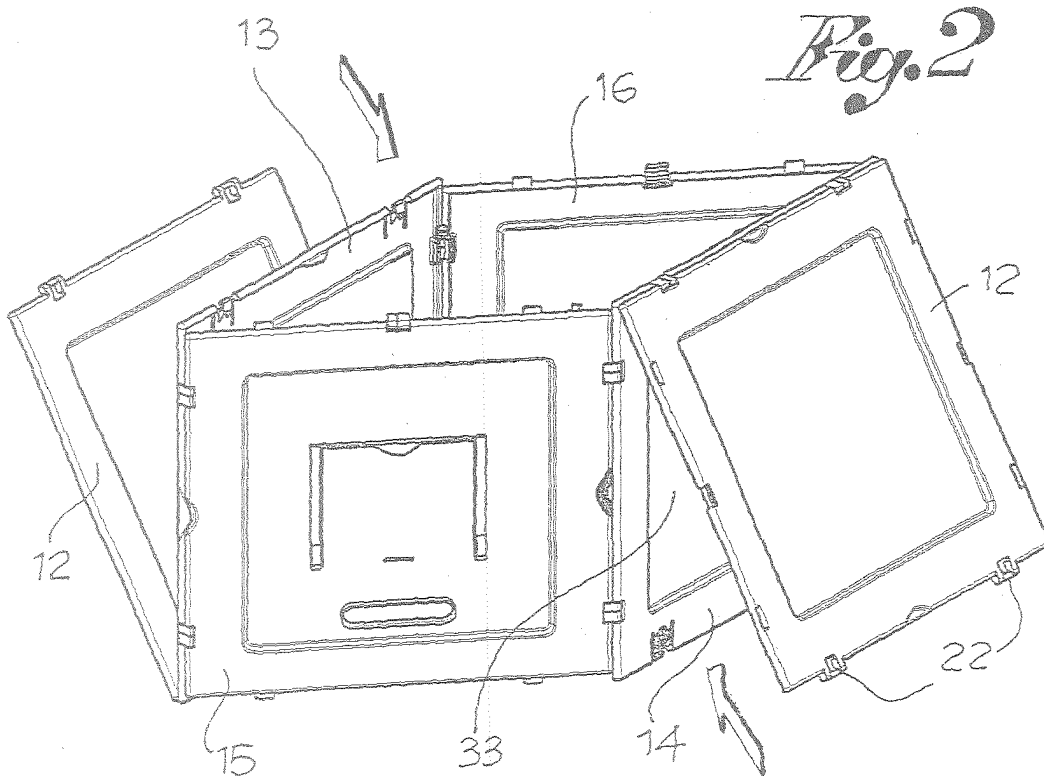
(30) Priority: **25.06.2004 IT BS20040076**

(71) Applicant: **OMPLAST S.r.l.**  
**24069 CENATE SOTTO (Bergamo) (IT)**

(54) **Folding container**

(57) The object of the present invention is a folding container comprising a bottom (11), a cover (12) and four side walls (13,14,15,16), wherein the cover and the

bottom are fully foldable on respective side walls and wherein two adjacent side walls are fully foldable on the other two.



**EP 1 609 728 A2**

## Description

**[0001]** The object of the present invention is a folding container of the type having a bottom, a cover and four side walls.

**[0002]** Containers capable of being changed from a use configuration to a little overall dimension configuration to facilitate carriage and storage, and vice versa, are already known. The elements forming these containers are usually connected to one another by hinged devices and coupling means.

**[0003]** However, it is an object of the present invention to propose a folding container having such structural features as to minimise its overall dimensions when folded while being such as to impart considerable sturdiness and strength to the structure when in use configuration and also in the event it is entirely made of plastic material.

**[0004]** Such object is achieved by a container according to the following claims.

**[0005]** Further features and advantages of the container according to the present invention will appear more clearly from the following description of a preferred embodiment, made by way of an indicative non-limiting example with reference to the annexed drawings, wherein:

**[0006]** figure 1 shows a perspective view of the container according to the present invention in use configuration;

**[0007]** figure 2 shows the container in a folding step;

**[0008]** figure 3 shows a perspective view of the folded container;

**[0009]** figure 4 shows a front view of the folded container;

**[0010]** figure 5 shows a front view of the container;

**[0011]** figure 6 shows a cross section of the container along line A-A in figure 5;

**[0012]** figure 6a shows an enlarged view of the circled detail "a" in figure 6;

**[0013]** figure 6b shows an enlarged view of the circled detail "b" in figure 6;

**[0014]** figure 7 shows a front view of the container from another angle;

**[0015]** figure 8 shows a cross section of the container along the broken line B-B in figure 7;

**[0016]** figure 8a shows an enlarged view of the circled detail "a" in figure 8;

**[0017]** figure 8b shows an enlarged view of the circled detail "b" in figure 8;

**[0018]** figure 9 shows a cross section of the container along the broken line C-C in figure 7;

**[0019]** figure 9a shows an enlarged view of the circled detail "a" in figure 9;

**[0020]** figure 9b shows an enlarged view of the circled detail "b" in figure 9;

**[0021]** figure 10 shows the container upturned and with the cover open; and

**[0022]** figure 11 shows an example of stacking of mul-

tiple containers on a pallet.

**[0023]** The folding container according to the present invention exhibits a parallelepiped structure comprising a bottom 11, a cover 12 and four side walls 13, 14, 15 and 16.

**[0024]** Cover 12 and a first side wall 13 are connected by hinged means 17 for a full folding of the cover on said first wall.

**[0025]** Cover 12 and a second side wall 14 opposed to the first one have respective locking means 18 engageable with one another in a coupling configuration to constrain the container in the use configuration.

**[0026]** Similarly, bottom 11 and the second side wall 14 opposed to the first one are connected by hinged means 17 for a full folding of the bottom on said second wall 14. Bottom and the first side wall 13 have respective locking means 18 engageable with one another in a coupling configuration to constrain the container in the use configuration.

**[0027]** Each of the four side walls 13-16 is in turn connected to the adjacent walls by hinged means 17 adapted for allowing full folding of two adjacent side walls on the other two. In other words, when the container is folded, two opposed angles delimited by adjacent side walls open up to form a flat angle, whereas the other two close, passing from ninety degrees to zero degrees.

**[0028]** According to a preferred embodiment, the hinged means 17 comprise at least one hinge pin 19 on each of the two hinged sides and a joint 20 having two parallel cylindrical seats 21 wherein said pins 19 are turnably seated (figure 6a).

**[0029]** Advantageously, the two seats 21 present a C shape that allows press application of joint 20 to pins 19. Moreover, the distance between centres of the two seats 21 for pins 19 is selected based on the thickness of the container faces so as to allow complete overlapping of the two hinged faces.

**[0030]** Advantageously, moreover, at least joints 20 that connect the pairs of side walls that, during the folding of the container, open up to forming a flat angle with one another, face towards one of said walls, thus forming two edges at ninety degrees 20' that, acting as stop shoulders, prevent any undesired movement of said wall relative to the joint (figure 9a). This is especially advantageous when the container is totally filled to prevent it from deforming, thus preventing the cover closing.

**[0031]** According to a preferred embodiment, the locking means 18 comprise at least one eyebolt 22 obtained on one of the two faces or walls to couple and an elastic hook 23 obtained on the other of said two faces or walls and intended to engage in said eyebolt. Advantageously, each elastic hook 23 comprises an elastic tab 23' obtained in a side of the wall to couple and a coupling portion 23" that extends from the free end of said elastic tab (figure 6b).

**[0032]** In an advantageous embodiment, the third and the fourth side walls 15, 16 and the two opposed sides of bottom 11 and of cover 12 adjacent to them exhibit

respective complementary centring means for an alignment of the bottom and of the cover with said walls during the assembly of the container to the use configuration.

**[0033]** In an example of embodiment, the complementary centring means comprise at least one tooth 24 extending from at least one side of the side walls 15, 16 and a groove 25 obtained in the corresponding side of the bottom and of the cover for receiving said tooth, or vice versa (figure 8a).

**[0034]** According to a particularly advantageous alternative embodiment, the third and the fourth side walls 15, 16 and the two opposed sides of bottom 11 adjacent to them exhibit second locking means 26 engageable with one another in a coupling relation. For example, said second locking means 26 comprise at least one pin 27 on each of the two sides to constrain and a coupling element 28 turnably constrained to one of said pins and connectable by pressure to the other of said pins (figure 8b).

**[0035]** In order to improve the stability of the container in the use configuration, bottom 11 and cover 12 exhibit, along the side intended to couple to the respective side walls 13, 14, a horizontal tab 29 adapted for abutting on a lowered portion 30 obtained along the side of said side walls.

**[0036]** To the same end, at the angles between the pairs of adjacent side walls intended to close on one another during the folding of the container, there is provided an anti-rotation tooth 31 that, extending from a vertical edge of a wall in a direction orthogonal to it, abuts on the outer face of the adjacent wall, thus limiting said angle in a ninety degree opening. Similarly, at the angles between the pairs of adjacent side walls intended to open during the folding of the container, there is provided an anti-rotation square 34 that, extending from a vertical edge of a wall, abuts on the inner side of the adjacent side wall, thus limiting said angle in a ninety degree closing.

**[0037]** According to a preferred embodiment, the container is shaped to allow a steady stacking of multiple containers on top of one another. To this end, at least one foot 32 extends from bottom 11, preferably four, suitably spaced, for resting on an underlying surface. Cover 12 exhibits a lowered central portion adapted for receiving the support foot of a similar container resting on top of it. Said lowered portion 33 serves as a guide for the container above and allows reducing the space occupied in height by multiple stacked containers.

**[0038]** Moreover, the side wall on which bottom 11 can be folded also exhibits a lowered central portion 33 adapted for receiving the support foot of the bottom when the container is in the folded configuration.

**[0039]** Advantageously, the container is fully made of a plastic material. As there are no metal parts and/or other materials, the container is completely recyclable.

**[0040]** The container according to the present invention can therefore be fully folded starting from the use

configuration by simply releasing the cover from the side wall to which it is constrained, by simple pressure on the elastic hooks, tilting the cover on the side wall to which it is hinged, overturning the container, releasing the bottom from the side walls, tilting it on the side wall to which it is hinged, and pressing two opposed edges of the side walls towards one another up to cause the full folding of two side walls on the other two.

**[0041]** In the practice the container, when folded, exhibits a height equal to three stacked walls and a maximum width equal to two sided walls, as it is clear in figures 3 and 4. The volume reduction between the use and the folded configuration is about 83%.

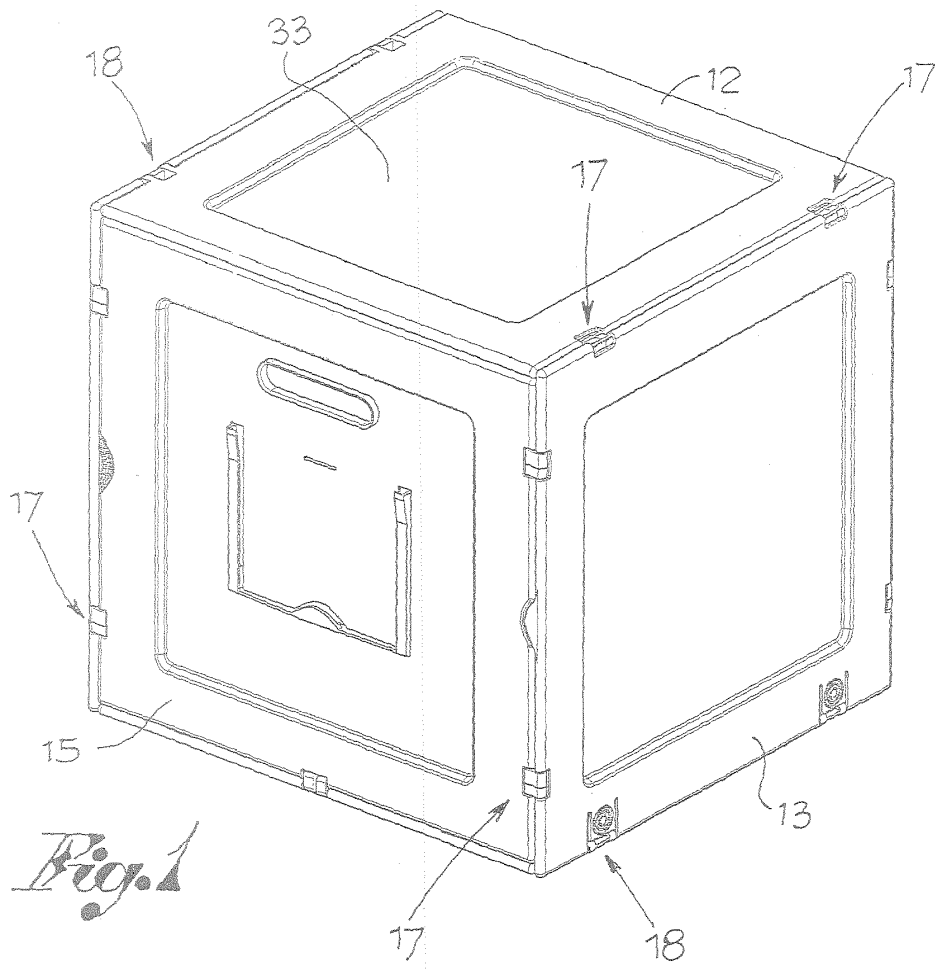
**[0042]** Finally, it should be noted that the container proposed here can be obtained starting from a single module and that, suitable adapted, can carry out the different functions typical of the six faces of the container. In this way it is possible to obtain the four side walls, the bottom and the cover with a single die fitted with suitable interchangeable inserts.

### Claims

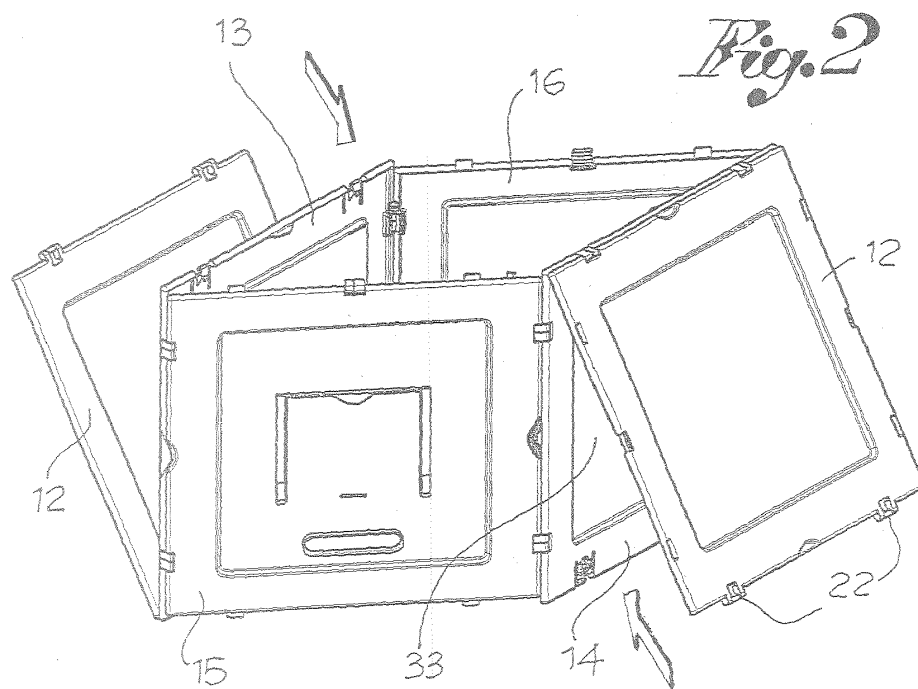
1. Folding container comprising a bottom (11), a cover (12) and four side walls (13-16), wherein:
  - the cover (12) and a first side wall (13) are connected by hinged means (17) for a full folding of the cover on said first wall,
  - the cover (12) and a second side wall (14) opposed to the first one exhibit respective locking means (18) engageable with one another in a coupling configuration,
  - the bottom (11) and said second side wall (14) are connected by hinged means (17) for a full folding of the cover on said second wall,
  - the bottom (11) and said first side wall (13) opposed to the second one exhibit respective locking means (18) engageable with one another in a coupling configuration, and wherein
  - each of the four side walls is connected to the adjacent walls by hinged means (17) adapted for allowing full folding of two adjacent side walls on the other two.
2. Container according to claim 1, wherein the third and the fourth side walls (15, 16) and the two opposed sides of the cover adjacent to them exhibit respective complementary centring means (24, 25) for an alignment of the cover with said walls during the assembly of the container.
3. Container according to claim 1 or 2, wherein the third and the fourth side walls (15, 16) and the two opposed sides of the bottom adjacent to them exhibit respective complementary centring means (24, 25) for an alignment of the bottom with said

walls during the assembly of the container.

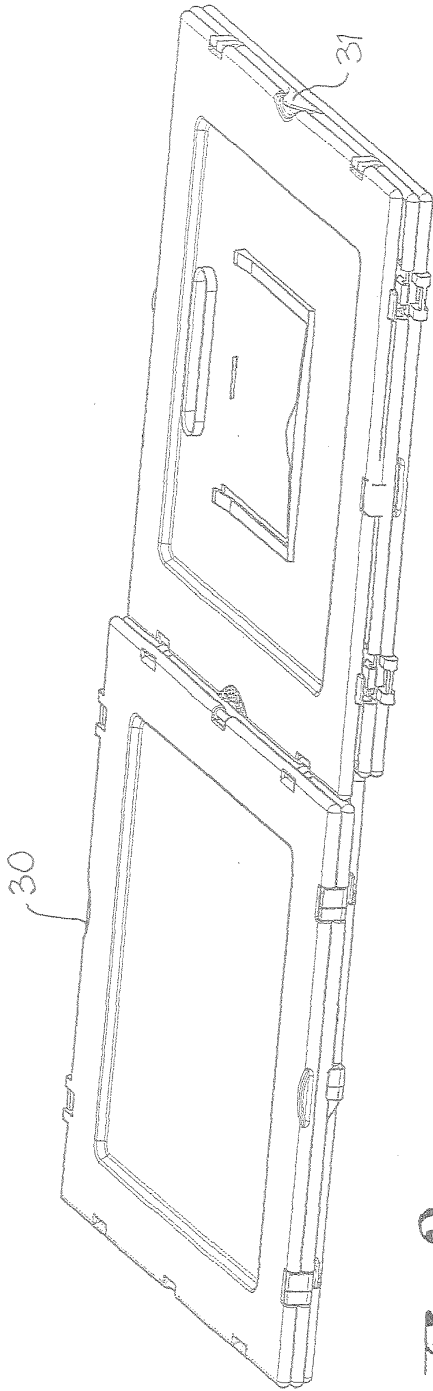
4. Container according to any one of the previous claims, wherein the third and the fourth side walls (15, 16) and the two opposed sides of the bottom adjacent to them exhibit respective second locking means (26) engageable with one another in a coupling relation. 5
5. Container according to any one of the previous claims, wherein the hinged means (17) comprise at least one hinge pin (19) on each of the two hinged sides and a joint (20) having two parallel cylindrical seats (21) wherein said pins are turnably seated. 10
6. Container according to any one of the previous claims, wherein said locking means (18) comprise at least one eyebolt (22) obtained on one of the two walls to couple and an elastic hook (23) obtained on the other of said two walls and intended to engage in said eyebolt. 15
7. Container according to claim 6, wherein each elastic hook comprises an elastic tab (23') obtained in a side of the wall to couple and a coupling portion (23'') that extends from the free end of said elastic tab. 20
8. Container according to any one of claims from 2 to 7, wherein said complementary centring means comprise at least one tooth (24) extending from a side of one between the cover and the side walls and a groove (25) obtained in the side of the other between said cover and side walls and adapted for receiving said tooth. 25
9. Container according to any one of claims from 3 to 8, wherein said complementary centring means comprise at least one tooth (24) extending from a side of one between the bottom and the side walls and a groove (25) obtained in the side of the other between said bottom and side walls and adapted for receiving said tooth. 30
10. Container according to any one of claims from 4 to 9, wherein said second locking means (26) comprise at least one pin (27) on each of the two sides to constrain and a coupling element (28) constrained to one of said pins and connectable by pressure to the other of said pins. 35
11. Container according to any one of the previous claims, wherein the cover and/or the bottom exhibit, along the side intended to couple to the respective side wall, a horizontal tab (29) intended to abut on a lowered portion (30) obtained along the side of said side wall. 40
12. Container according to any one of the previous claims wherein, at the angles between the pairs of adjacent side walls intended to close on one another during the folding of the container, there is provided an anti-rotation tooth (31) that, extending from a vertical edge of a wall in a direction orthogonal to it, abuts on the outer face of the adjacent wall, thus limiting said angle in a ninety degree opening. 45
13. Container according to any one of the previous claims wherein, at the angles between the pairs of adjacent side walls intended to open during the folding of the container, there is provided an anti-rotation square (34) that, extending from a vertical edge of a wall, abuts on the inner side of the adjacent side wall, thus limiting said angle in a ninety degree closing. 50
14. Container according to any one of the previous claims, wherein at least one support foot (32) extends from the bottom and wherein the cover exhibits a lowered central portion (33) adapted for receiving the foot of a similar container resting onto it. 55
15. Container according to claim 14, wherein the side wall on which the bottom can be folded exhibits a lowered central portion (33) adapted for receiving the support foot of the bottom.
16. Container according to any one of the previous claims, **characterised in that** it is entirely made of a plastic material.
17. Method for folding a folding container according to any one of the previous claims, from a use configuration to a little overall dimension configuration, comprising the steps of:
  - tilting the cover on a first side wall;
  - overturning the container;
  - tilting the bottom on a second side wall opposed to the first one;
  - pressing two opposed edges of the side walls towards each other up to obtain the full folding of two adjacent side walls on the other two.



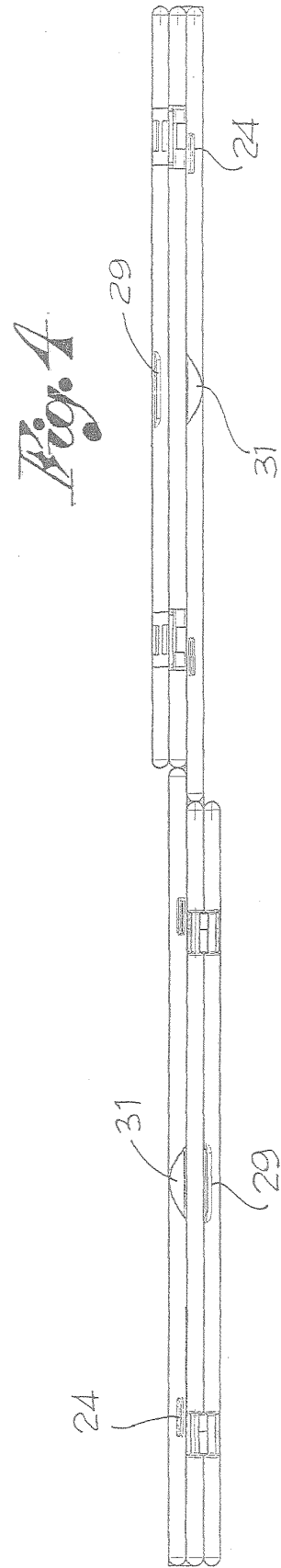
*Fig. 1*



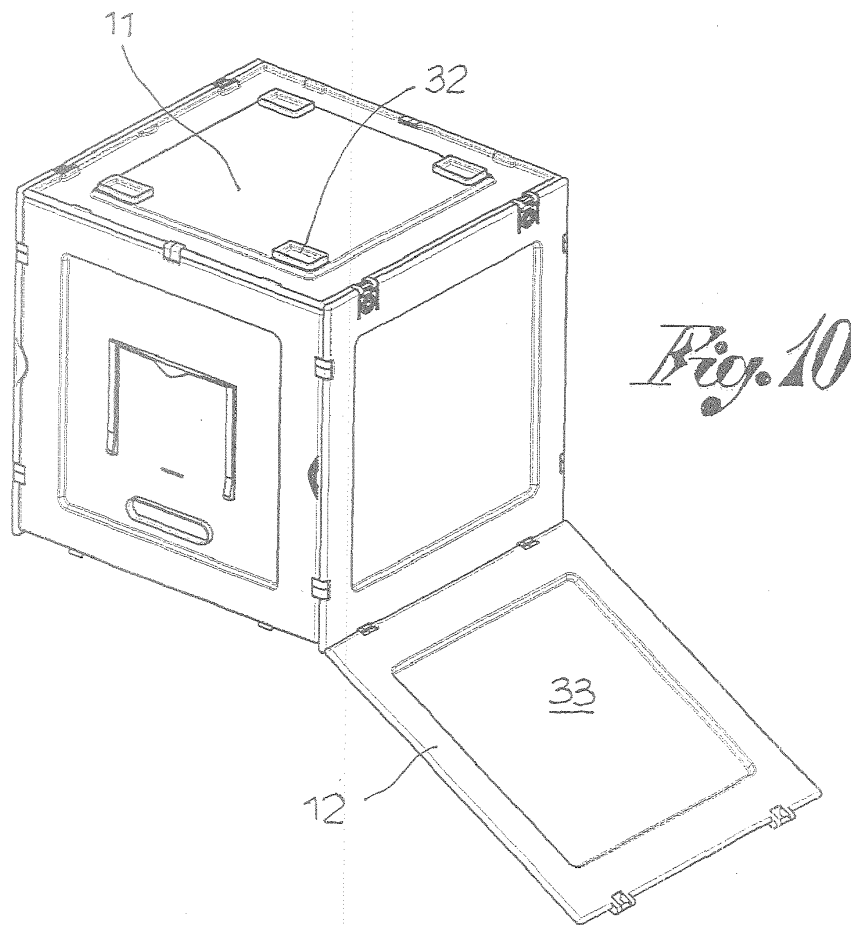
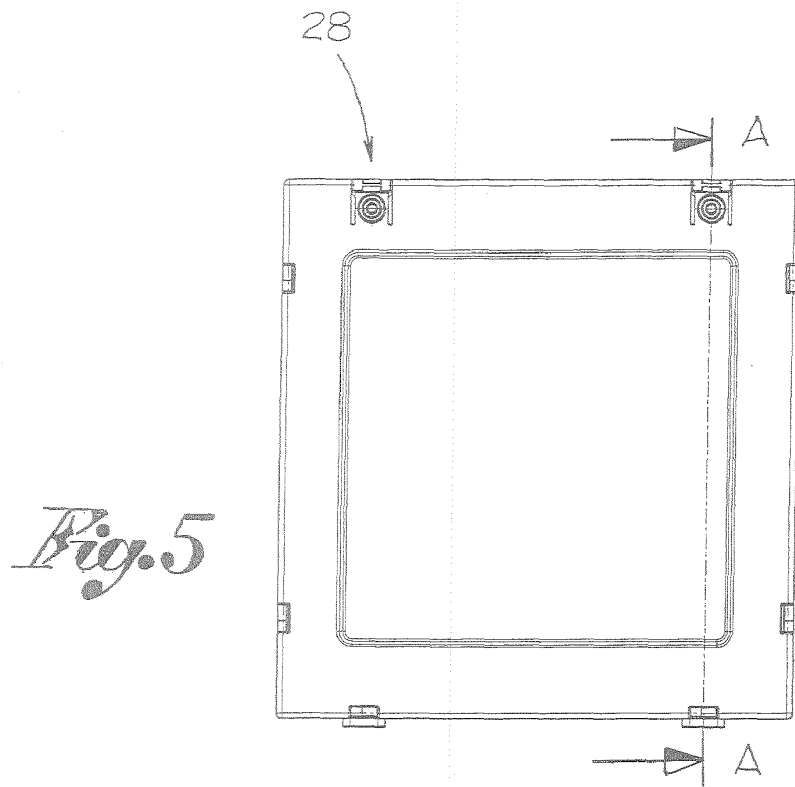
*Fig. 2*

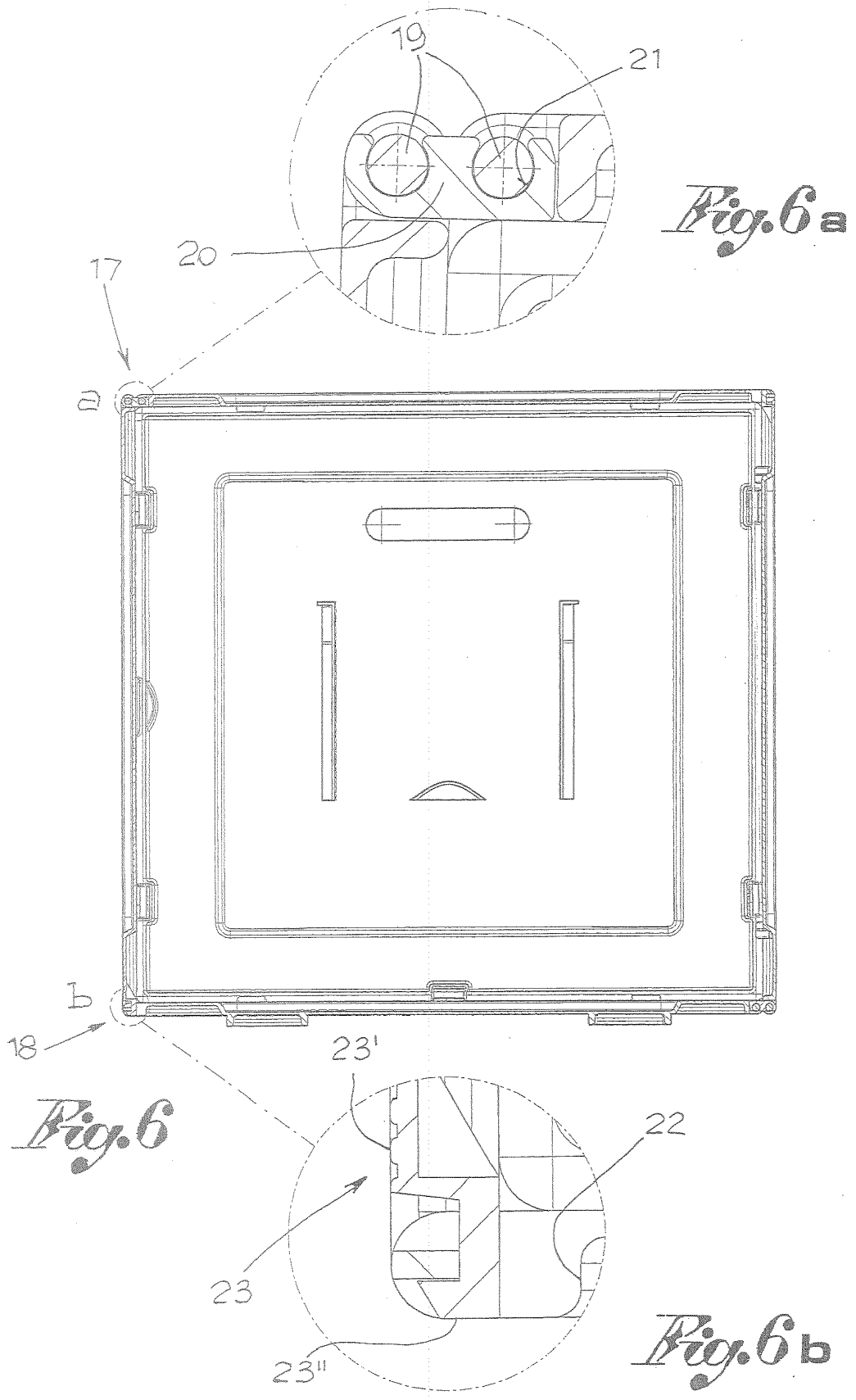


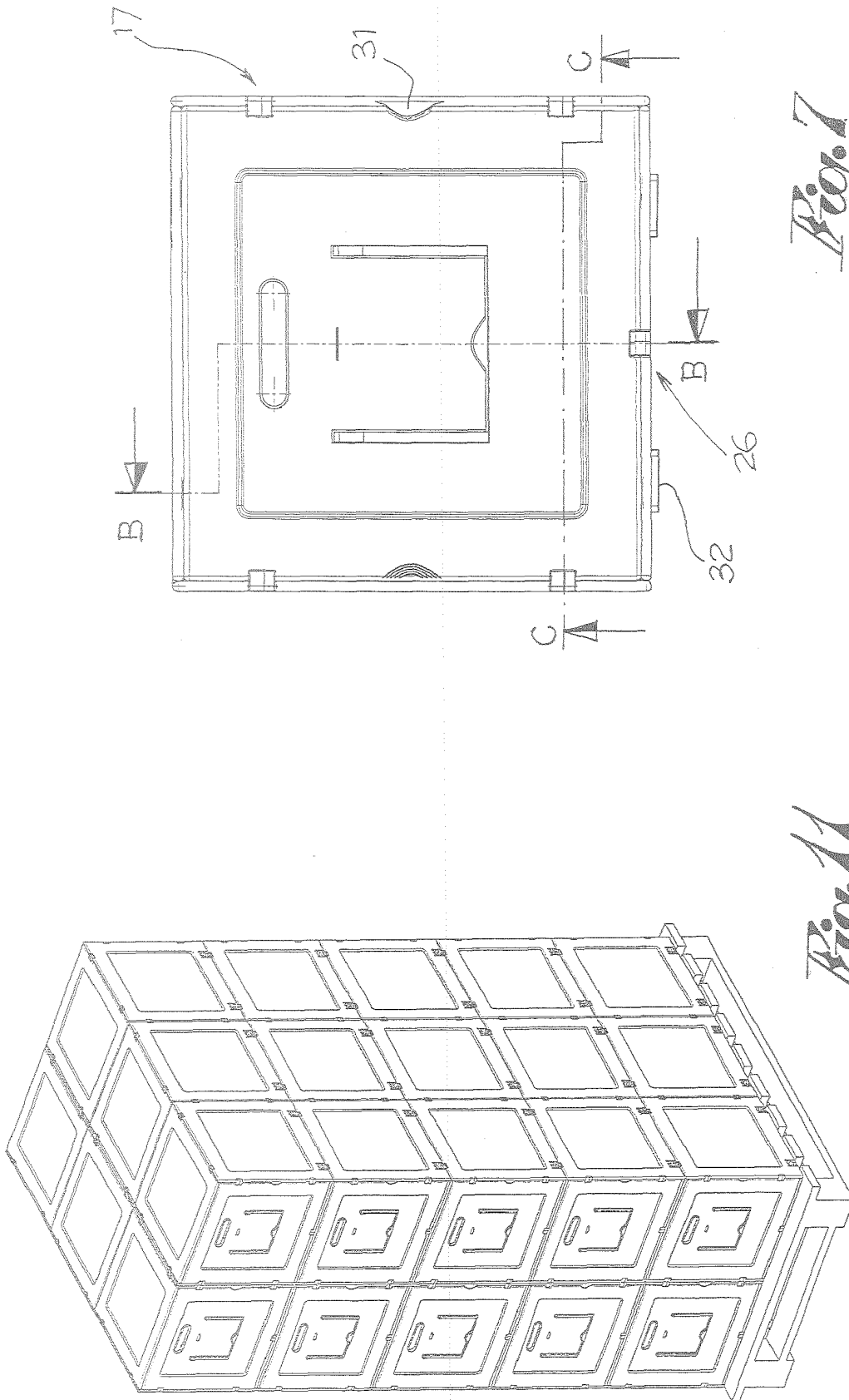
*Fig. 3*



*Fig. 4*







*Fig. 7*

*Fig. 11*

