

(19) World Intellectual Property Organization
International Bureau



(43) International Publication Date
16 October 2003 (16.10.2003)

PCT

(10) International Publication Number
WO 03/085992 A1

- (51) International Patent Classification⁷: H04Q 7/20, H04M 1/66, 1/68, 3/16, H04B 1/38
- (74) Agents: GALLIANI, William, S.; Cooley Godward LLP, 3000 El Camino Real, Five Palo Alto Square, Palo Alto, CA 94306-2155 et al. (US).
- (21) International Application Number: PCT/US03/04485
- (81) Designated States (national): AE, AG, AL, AM, AT, AU, AZ, BA, BB, BG, BR, BY, BZ, CA, CH, CN, CO, CR, CU, CZ, DE, DK, DM, DZ, EC, EE, ES, FI, GB, GD, GE, GH, GM, HR, HU, ID, IL, IN, IS, JP, KE, KG, KP, KR, KZ, LC, LK, LR, LS, LT, LU, LV, MA, MD, MG, MK, MN, MW, MX, MZ, NO, NZ, OM, PH, PL, PT, RO, RU, SC, SD, SE, SG, SK, SL, TJ, TM, TN, TR, TT, TZ, UA, UG, UZ, VC, VN, YU, ZA, ZM, ZW.
- (22) International Filing Date: 14 February 2003 (14.02.2003)
- (25) Filing Language: English
- (26) Publication Language: English
- (30) Priority Data:

10/116,311	2 April 2002 (02.04.2002)	US
10/115,767	2 April 2002 (02.04.2002)	US
10/116,023	2 April 2002 (02.04.2002)	US
10/115,835	2 April 2002 (02.04.2002)	US
10/116,186	2 April 2002 (02.04.2002)	US
10/115,833	2 April 2002 (02.04.2002)	US
10/115,774	2 April 2002 (02.04.2002)	US
- (84) Designated States (regional): ARIPO patent (GH, GM, KE, LS, MW, MZ, SD, SL, SZ, TZ, UG, ZM, ZW), Eurasian patent (AM, AZ, BY, KG, KZ, MD, RU, TJ, TM), European patent (AT, BE, BG, CH, CY, CZ, DE, DK, EE, ES, FI, FR, GB, GR, HU, IE, IT, LU, MC, NL, PT, SE, SI, SK, TR), OAPI patent (BF, BJ, CF, CG, CI, CM, GA, GN, GQ, GW, ML, MR, NE, SN, TD, TG).

- (71) Applicant: KINETO WIRELESS, INC. [US/US]; 2121B Ringwood Avenue, San Jose, CA 95131 (US).
- (72) Inventor: MOHAMMED, Jahangir; 387 Martens Avenue, Mountain View, CA 94040 (US).

Published:
— with international search report

For two-letter codes and other abbreviations, refer to the "Guidance Notes on Codes and Abbreviations" appearing at the beginning of each regular issue of the PCT Gazette.

(54) Title: METHOD FOR EXTENDING THE COVERAGE AREA OF A WIRELESS COMMUNICATION

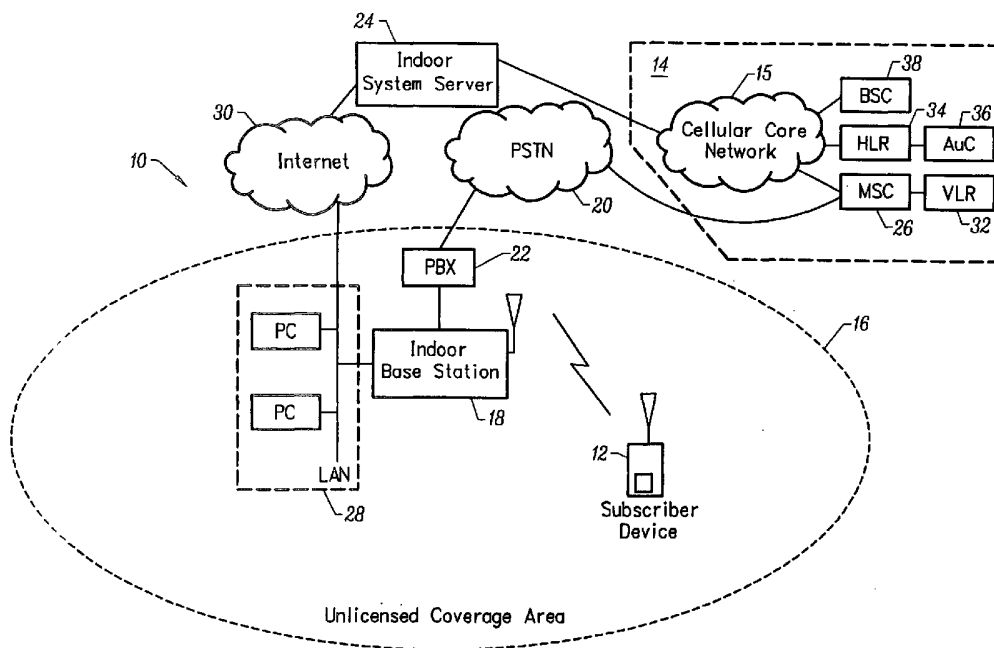

(57) Abstract: A method of integrating a licensed system (14) and an unlicensed wireless system (16) includes a wireless communication session in a first region serviced by a first wireless system and maintaining the wireless communication session in a second region serviced by a second wireless system. The first wireless system is selected from the group including a licensed wireless system and an unlicensed wireless system. The second wireless system is the unselected system from the group including the licensed wireless system and the unlicensed wireless system.

WO 03/085992 A1

**METHOD FOR EXTENDING THE COVERAGE AREA OF A LICENSED
WIRELESS COMMUNICATIONS SYSTEM USING AN UNLICENSED WIRELESS
COMMUNICATIONS SYSTEM**

[0001] This application claims priority to the following U.S. utility patent applications: 10/116,311; 10/115,767; 10/116,023; 10/115,835; 10/116,186; 10/115,833; and 10/115,774, each of which was filed on April 2, 2002.

BRIEF DESCRIPTION OF THE INVENTION

[0002] This invention relates generally to telecommunications. More particularly, this invention relates to a technique for seamlessly integrating voice and data telecommunication services across a licensed wireless system and an unlicensed wireless system.

BACKGROUND OF THE INVENTION

[0003] Licensed wireless systems provide mobile wireless communications to individuals using wireless transceivers. Licensed wireless systems refer to public cellular telephone systems and/or Personal Communication Services (PCS) telephone systems. Wireless transceivers include cellular telephones, PCS telephones, wireless-enabled personal digital assistants, wireless modems, and the like.

[0004] Licensed wireless systems utilize wireless signal frequencies that are licensed from governments. Large fees are paid for access to these frequencies. Expensive base station equipment is used to support communications on licensed frequencies. Base stations are typically installed approximately a mile apart from one another. As a result, the quality of service (voice quality and speed of data transfer) in wireless systems is considerably inferior to the quality of service afforded by landline (wired) connections. Thus, the user of a licensed wireless system pays relatively high fees for relatively low quality service.

[0005] Landline (wired) connections are extensively deployed and generally perform at a lower cost with higher quality voice and higher speed data services. The problem with landline connections is that they constrain the mobility of a user. Traditionally, a physical connection to the landline was required. Currently, unlicensed wireless communication systems are deployed to increase the mobility of an individual using a landline. The mobility range associated with such systems is typically on the order of 100 meters. A common unlicensed wireless communication system includes a base station with a physical connection to a landline. The base station has a RF transceiver to facilitate communication

with a wireless handset that is operative within a modest distance of the base station. Thus, this option provides higher quality services at a lower cost, but the services only extend a modest distance from the base station.

[0006] Thus, there are significant shortcomings associated with current landline systems and licensed wireless systems. For this reason, individuals commonly have one telephone number for landline communications and one telephone number for licensed wireless communications. This leads to additional expense and inconvenience for an individual. It would be highly desirable if an individual could utilize a single telephone number for both landline communications and licensed wireless communications. Ideally, such a system would allow an individual, through seamless handoffs between the two systems, to exploit the benefits of each system.

SUMMARY OF THE INVENTION

[0007] A method of integrating a licensed wireless system and an unlicensed wireless system includes initiating a wireless communication session in a first region serviced by a first wireless system and maintaining the wireless communication session in a second region serviced by a second wireless system. The first wireless system is selected from the group including a licensed wireless system and an unlicensed wireless system. The second wireless system is the unselected system from the group including the licensed wireless system and the unlicensed wireless system.

[0008] Advantageously, services that would typically be provided via a licensed wireless system can be delivered to the unlicensed base station using inexpensive and high quality landline networks. The unlicensed base station subsequently provides service to a handset using unlicensed, free spectrum (e.g., spectrum around 2.4 GHz or 5 GHz). Thus, when a subscriber is within range of the unlicensed base station, the subscriber enjoys low cost, high speed, and high quality voice and data services. In addition, the subscriber enjoys extended service range since the handset can receive services deep within a building. This type of service range is not reliably provided by a licensed wireless system.

[0009] The invention also allows the subscriber to roam outside the range of the unlicensed base station without dropping communications. Instead, roaming outside the range of the unlicensed base station results in a seamless handoff (also referred to as a hand over) wherein communication services are automatically provided by the licensed wireless system.

[0010] While the invention provides advantages to the subscriber, the invention also provides advantages to the wireless system service provider. First, the unlicensed base stations are relatively low cost and therefore the wireless system service provider is in a position to extend services without incurring significant infrastructure expense. Further, the integration of the landline and wireless systems allows a single communication service provider to secure fee-paying accounts for both landline and wireless services. Finally, since the invention relies upon installed wireless system infrastructure for services such as authentication, expensive system upgrades are not required.

BRIEF DESCRIPTION OF THE FIGURES

[0011] The invention is more fully appreciated in connection with the following detailed description taken in conjunction with the accompanying drawings, in which:

[0012] FIG. 1 illustrates an apparatus for integrating a licensed wireless system and an unlicensed wireless system in accordance with an embodiment of the invention.

[0013] FIG. 2 illustrates a subscriber device configured in accordance with an embodiment of the invention.

[0014] FIG. 3 illustrates a base station configured in accordance with an embodiment of the invention.

[0015] FIGS. 4A-4D illustrate various base station configurations utilized in accordance with embodiments of the invention.

[0016] FIG. 5 illustrates a system server for integrating unlicensed and licensed wireless communication systems in accordance with an embodiment of the invention.

[0017] FIG. 6 illustrates a base station service region and associated transition points between licensed and unlicensed wireless communication services.

[0018] FIG. 7 illustrates a transition between an unlicensed wireless service and a licensed wireless service in accordance with an embodiment of the invention.

[0019] FIG. 8 illustrates transitions between unlicensed wireless base stations in accordance with an embodiment of the invention.

[0020] FIG. 9 illustrates the forwarding of a licensed wireless call to a base station in accordance with an embodiment of the invention.

[0021] FIG. 10 illustrates a prior art licensed wireless authentication procedure.

[0022] FIG. 11 illustrates an unlicensed wireless authentication procedure utilized in accordance with an embodiment of the invention.

[0023] FIG. 12 illustrates system components utilized in a provisioning operation associated with an embodiment of the invention.

[0024] FIG. 13 illustrates provisioning operations performed in accordance with an embodiment of the invention.

[0025] Like reference numerals refer to corresponding parts throughout the several views of the drawings.

DETAILED DESCRIPTION OF THE INVENTION

[0026] FIG. 1 illustrates a system 10 that may be operated in accordance with an embodiment of the present invention. The system 10 includes a subscriber device 12, which is a wireless transceiver, such as a cellular telephone, a PCS telephone, a wireless data modem, a wireless enabled Personal Digital Assistant, a wireless enabled computer, and the like. This subscriber device 12 is in wireless electronic communication with a licensed wireless communication service that provides voice and/or data services. By way of example, the invention is disclosed in connection with a licensed wireless communication service in the form of a cellular network 14. When the subscriber device 12 is within an unlicensed wireless service coverage area 16, the licensed wireless service is substituted, without interruption, with an unlicensed wireless service that is facilitated through a base station 18.

[0027] The base station 18 wirelessly transmits telephone signals from a standard Public Switched Telephone Network (PSTN) 20 and, if necessary, a standard Private Base eXchange (PBX) 22, to a subscriber device 12. Specifically, when a device 12 is within an unlicensed wireless service coverage area 16, the originating base station 18 provides the device 12 with wireless telephone service originating from a PSTN 20 rather than a cellular network 14. Since the PSTN 20 is used, the subscriber device 12 receives high quality voice or data services at a relatively low cost. If the user of the subscriber device 12 roams outside of the unlicensed wireless service coverage area 16, the same communication session can be maintained without interruption by transitioning to the licensed wireless service provided by the cellular network 14. Techniques for implementing seamless transitions of this type are discussed in detail below.

[0028] A system server 24 facilitates seamless transitions between the licensed wireless service and the unlicensed wireless service. The system server 24 is in electronic communication with the standard cellular network 14. In one embodiment of the invention

as shown in FIG. 1, the system server 24 is also in electronic communication with the base station 18 through a Local Area Network (LAN) 28 and a larger network 30, such as the Internet. The system server 24 and the base station 18 may be linked through any number of communication services, including Digital Subscriber Line (DSL), cable, satellite, and the like.

[0029] FIG. 1 illustrates that the cellular network 14 includes standard components, such as a cellular core network 15, a Mobile Switching Center (MSC) 26, Visitor Location Register (VLR) 32, a Home Location Register (HLR) 34, an Authentication Center (AC) 38, and a Base Station Controller (BSC) 38. As discussed below, these standard components are utilized in a novel manner in order to provide extended functionality for a subscriber device 12.

[0030] FIG. 2 illustrates a subscriber device 12. As previously indicated, the subscriber device 12 may be a wireless telephone or a wireless modem. In the case of a wireless telephone, the subscriber device 12 includes a display 100, keypad 102, and a control circuit 104. The display 100 may be used to provide a visual indication to a user when the subscriber device 12 is within the service range of the base station 18. The keypad 102 is used in a conventional manner. The control circuit 104 may be in the form of a processor, a hardwired circuit, a programmable logic device, an application specific integrated circuit, and the like.

[0031] The control circuit 104 is also connected to a memory module 106 and, via audio switch 108, to an audio input/output circuit 109. Wireless signals in the unlicensed spectrum are received by an antenna 110 and are filtered by a filter 112 to improve signal clarity and/or strength. The wireless signals are then processed by unlicensed wireless circuitry 114, which is also referred to as unlicensed wireless communication signal processing circuitry. The unlicensed wireless circuitry operates as a standard transceiver for processing unlicensed wireless signals. The circuitry 114 may support any number of unlicensed wireless standards. For example, currently in the U.S., unlicensed wireless signals may be sent at frequencies around 900 MHz, 2.4 GHz, or 5 GHz. Unlicensed wireless communication may be implemented in accordance with the invention utilizing any number of unlicensed spectrum communications protocols, including Bluetooth, IEEE 802.11a, IEEE 802.11b, and Hyper-LAN. Advantageously, many licensed wireless subscriber devices are currently being configured to include unlicensed wireless circuitry for such applications as remote microphones and speakers. In accordance with the

invention, this circuitry is used for a new application, namely, communicating with a base station, as discussed below.

[0032] Selected signals, such as location update data or signal strength data, are sent to the control circuit 104. Audio data is converted to an audio signal by audio circuitry 116 and is sent to an audio switch 108 for broadcast by an audio input/output circuit 109. Audio signals transmitted to the audio input/output circuit 109 are transmitted by audio switch 108 to the control circuit 104, which is capable of sending audio and other data to unlicensed wireless circuitry 114. Unlicensed spectrum signals are then sent through the filter 112 and on to the antenna 110, where they are broadcast to the base station 18.

[0033] In similar manner, wireless signals from a licensed cellular network 14 are transmitted to the antenna 111, filtered by the filter 113, and are then processed by the licensed wireless circuitry 118, also referred to as licensed wireless communication signal processing circuitry. These signals are subsequently converted to an audio signal by audio circuitry 120 or are processed by control circuit 104. As above, signals originating from the device 12 can also be sent out, but here the destination is a licensed wireless communication network (e.g., cellular network 14) rather than a base station 18. In the event of a data modem, the audio input/output circuit 109 is omitted and a data source is applied directly to the control circuit 104. Audio signals transmitted from the audio input 109 are transmitted by audio switch 108 to the control circuit 104, which is capable of sending audio and other data to licensed wireless circuitry 118. Wireless signals are then sent through the filter 113 to the antenna 111, where they are broadcast to the licensed wireless network 14.

[0034] The individual subscriber device components discussed up to this point are standard. The combination of these devices is believed to be novel, as is the operation of these devices in accordance with a set of executable programs stored in memory 106. The executable programs within memory 106 are shown by way of example. The same functionality may be realized through hardwired circuits, application specific integrated circuits, programmable logic devices, and the like. Indeed, the various components of the subscriber device 12 may be combined or integrated in any number of ways. The embodiment of Figure 2 is for the purpose of illustration.

[0035] The executable programs reside on top of standard licensed wireless system call processing software. In addition, the programs reside on top of standard unlicensed wireless link protocol software (e.g., standard Bluetooth or 802.11b software). The programs bridge these systems by exchanging messages between the separate software stacks.

Advantageously, this approach allows a large portion of the existing software protocols in the subscriber device 12 to be reused without any changes.

[0036] The memory module 106 contains a location tracking module 122 that records the current location of the device 12 (i.e., whether the device is within an unlicensed coverage area 16). In addition, the module 106 contains an authentication and authorization module 124 to coordinate an authentication procedure for validating that the device 12 is licensed for use within the unlicensed coverage area 16. As discussed below, the invention utilizes the authentication infrastructure associated with the licensed wireless system to authenticate and authorize a subscriber device for unlicensed wireless system services. The memory 106 also includes a handoff module 126 to coordinate seamless service exchanges between a base station 18 supporting unlicensed wireless communications and a licensed wireless communications network, such as a cellular network 14. The operations associated with each of the modules stored in memory 106 are discussed in further detail below.

[0037] FIG. 3 illustrates an embodiment of a base station 18 in accordance with an embodiment of the present invention. When the subscriber device 12 is within the coverage area 16 of the base station 18, the base station 18 can be used to provide the subscriber device 12 with landline quality data and voice service via an unlicensed wireless communication link. In particular, the base station 18 interconnects to the existing telephone network to provide a final link to a subscriber device 12 through a short-range two-way radio link.

[0038] In one embodiment of the invention, the base station 18 is controlled by a control circuit 200, which is in communication with the LAN 28 and therefore the system server 24 via router jack 202 and/or Ethernet jack 204. The control circuit 200 may be a processor, a hardwired circuit, a programmable logic device, an application specific integrated circuit and the like. Signals from the system server 24 travel through one of these jacks into network interface circuitry 206 and on to the control circuit 200. This allows the base station 18 to communicate with the system server 24. As discussed below, the server 24 determines whether and when to route phone service over the unlicensed wireless system (e.g., via the PSTN 20 and base station 18) or the licensed wireless system (e.g., via cellular network 14).

[0039] The control circuit 200 is also in communication with a landline (PSTN 20 and, in the typical business context, PBX 22) via a phone line jack 208 and/or phone extension jack 210. These jacks transmit information between the PSTN 20 and control circuit 200

through Plain Old Telephone Service (POTS) interface circuitry 212. Audio data is translated by audio circuitry 214, while other data can be directly exchanged with the control circuit 200.

[0040] The base station 18 communicates wirelessly with devices 12 using a radio frequency circuit 216. This circuit 216 includes standard circuitry to receive and transmit electronic voice and/or data in an unlicensed wireless signal format. For example, currently in the U.S., unlicensed wireless signals may be sent in the frequency range between 2.4 GHz and 5 GHz. Unlicensed wireless communication may be implemented in accordance with the invention utilizing any number of unlicensed spectrum communications protocols, including Bluetooth, IEEE 802.11a, IEEE 802.11b, and Hyper-LAN.

[0041] A typical circuit 216 consists of transmission circuitry 218 for transmitting signals to a device 12, receiving circuitry 220 for receiving signals from the device 12, and base band circuitry 222. The baseband circuitry 222 contains standard circuitry for down converting unlicensed wireless signals to base band signals, which allows for the extraction of relevant information by the control circuit 200. The base band circuitry 222 also contains standard circuitry for up converting base band data from the control circuit 200 to unlicensed wireless signals for broadcast by transmission circuitry 218.

[0042] The control circuit 200 is also connected to a memory module 224. The memory module 224 contains a provisioning module 226 that is used to facilitate the initial configuration and servicing of the base station 18 and subscriber device 12. The module 224 also includes a subscriber interface module 228. The subscriber interface module 228 instructs the control circuit 200 to periodically broadcast a signal (e.g., an unlicensed wireless communication base station identification signal). If a subscriber device 12 responds to the signal, then the base station 18 knows that the subscriber device 12 is within the unlicensed coverage area 16. The module 224 also contains an authentication module 230 to coordinate the authentication of a subscriber device 12 that has entered the unlicensed coverage area 16. In one embodiment of the invention, the memory 224 includes an enhanced service module 232. The enhanced service module may be used to provide improved services to a subscriber device. For example, if the user of a subscriber device is playing a low latency on-line game, different screen displays can be cached in the base station 18 and then be quickly downloaded to the subscriber device 12. Each of the modules stored in memory 224 can also be implemented as hardwired circuits, application specific integrated circuits, programmable logic devices, and the like.

[0043] The enhanced service module 232 may also be used to implement other advanced features. For example, the enhanced service module 232 can be configured to append a set of prefix digits before dialed digits to instruct the server 24 to route long distance calls on a specific service provider network.

[0044] The enhanced service module 232 can also be used to simultaneously support multiple subscribers. For example, the base station 18 may support multiple subscriber devices through a single or multiple landline connections.

[0045] Preferably, the subscriber interface module 228 of the base station 18 is configured to advise a subscriber device when the landline associated with the base station 18 is occupied. In such a case, the handoff module 126 of the subscriber device will no longer attempt to make contact with the base station 18, but will continue to utilize the licensed wireless system for call servicing.

[0046] In order to provide landline-quality service to subscriber devices 12, a base station 18 is installed directly in the path of a typical phone system. FIG. 4A illustrates a typical office or workplace, where a telephone 300 is connected to a PBX 22. The PBX 22 is installed between the telephone 300 and PSTN 20 to provide a private telephone network in which a number of telephones 300 share a certain number of outside lines from the PSTN 20. FIG. 4A illustrates that a Personal Computer (PC) 302 can be connected to the LAN 28 for communication with the Internet 30.

[0047] FIG. 4B illustrates the workplace environment of FIG. 4A modified to incorporate the base station 18 of the invention. The base station 18 is placed in electronic communication with both the telephone 300 (e.g., via phone line jack 208) and the LAN 28 (e.g., via Ethernet jack 204). This configuration allows base station 18 to receive landline voice and data from a PSTN 20 and broadcast it to subscriber devices 12 when they are within the coverage area 16. The base station 18 is also connected to a LAN 28, which allows it to communicate with the system server 24 in order to coordinate handoffs between the licensed wireless and unlicensed wireless systems. Advantageously, the base station 18 operates transparently with respect to the PBX 22, the LAN 28, the telephone 300, and the PC 302. In the event that the PBX 22 is Internet Protocol based, the base station 18 can be connected solely to the LAN 28.

[0048] FIG. 4C illustrates a typical home setting, which is usually similar to the workplace setting of FIG. 4A minus the LAN 28 and PBX 22. The telephone 300 is ordinarily connected directly with Plain Old Telephone Service (POTS) 304, which is simply another

term for PSTN 20. Connection to the Internet 30 is provided by a modem 306 in communication with a PC 302. FIG. 4D illustrates the placement of base station 18 within this typical home setting. Here, the base station 18 is placed in electronic communication with both a telephone 300 and modem 306, allowing it to communicate directly with the POTS 304/PSTN 20 and, through modem 306, with the Internet 30 and system server 24. Once again, the base station 18 operates transparently with respect to the modem 306, the POTS 304, the telephone 300, and the PC 302.

[0049] In both the workplace and home settings, the base station 18 can be in simultaneous communication with both a telephone landline and a system server 24. When a subscriber device 12 roams inside the coverage area 16, the base station 18 can thus provide landline-quality service to device 12. The invention should thus be construed to include an apparatus and method for the seamless switching of telephone service between a cellular network 14 and a landline-based base station 18 that can be used in either a residential or commercial setting.

[0050] As mentioned above, for purposes of this invention a landline can be interchangeably referred to as a POTS 304 or PSTN 20. However, the invention should not be construed as limited to simply the POTS or PSTN context. Rather, the invention discloses a base station 18 that can provide landline-quality service to a subscriber device 12 by communicating with any landline network. Examples of such networks include, but are not limited to, DSL, cable or cable modem networks.

[0051] FIG. 5 illustrates a system server 24, which manages the mobility of subscriber devices 12 between a landline-based unlicensed wireless service from a base station 18 and a licensed wireless service, such as from a cellular network 14. A typical system server 24 is controlled by a central processing unit (CPU) 400, which is connected to a bus 401. Network interface cards 402 (e.g., Ethernet cards) for communicating with the Internet 30 are also connected to the bus 401. Licensed network interface cards 404 (e.g., SS7 cards) for communicating with cellular networks 14 are also connected to the bus 401. This allows the system server 24 to use Internet Protocol (IP) and/or SS7 protocol and/or MAP & IS-41 protocols to connect to the Internet and cellular core networks.

[0052] The system server 24 also contains a memory module 406 that stores a number of programs, databases and other assorted modules. More specifically, the module 406 contains signaling control programs 408. The signaling control programs 408 are standard programs for establishing communications with the licensed wireless network. Therefore,

for example, the signaling control programs 408 may include a Transaction Capability Application Part (TCAP) module, a Message Transfer Part (MTP) module, and an Interim Standard (IS41) module to support Time Division Multiple Access (TDMA) and Code Division Multiple Access (CDMA). Memory 46 may also store datapath control programs 410. By way of example, the datapath control programs may include standard programs to facilitate computer network data transfers. By way of example, the datapath control programs may include an Internet Protocol (IP) module and a Gateway Tunnel Protocol (GTP) module.

[0053] The memory 406 also stores various system server application programs 412. These application programs include system bridge programs 414 for handling transitions in service from licensed to unlicensed wireless services and vice versa. The memory 406 also stores a location database 416 for storing the current location of devices 12 and indicating whether they are within the coverage area 16. Also included is a billing module 418 for recording usage statistics for billing purposes. The billing module 418 distinguishes between charges for licensed wireless services and unlicensed wireless services. A provisioning module 420 is included to facilitate the installation of new base stations. An authentication module 422 is used to facilitate the authentication of a subscriber device within an unlicensed wireless service area. As discussed below, the authentication module 422 includes data and executable instructions to emulate certain components of a licensed wireless network. For example, the authentication module emulates a mobile switching center during the authentication process.

[0054] The major components of the invention – the subscriber device 12, the base station 18, and the system server 24 – have now been described. The operations of these devices are more fully appreciated with the following discussion.

[0055] The invention's facilitation of seamless transitions between licensed and unlicensed wireless services is more fully appreciated in connection with FIG. 6. Base station 18 broadcasts within a set of boundaries B1, B2, B3 and B4. A subscriber device 12 located outside these boundaries is serviced by a licensed wireless system, such as a standard cellular network 14. However, once the device 12 crosses boundary B3, the handoff from the licensed wireless service to the unlicensed wireless service begins. That is, at the B3 boundary the base station 18 is able to recognize the presence of the subscriber device 12. As previously indicated, the base station 18 includes a subscriber interface module 228 that coordinates the transmission of a service range signal that is identified by a subscriber

device 12. That is, the location tracking module 122 of the subscriber device 12 is used to coordinate the identification of a base station signal. In the presence of such a signal, the location tracking module 122 coordinates the transmittal of an acknowledgment signal to the base station 18.

[0056] Preferably, the subscriber interface module 228 of the base station 18 identifies the boundary points of the service area 16 by using the received signal strength and the transmit-power level setting from the subscriber device 12. In particular, an automated process is preferably used to learn the boundary distances through heuristically measuring the success rate and adjusting the boundary distance for optimal handoff success rates.

[0057] In one embodiment, the location tracking module 122 of the subscriber device 12 is implemented to periodically wake the unlicensed wireless circuitry 114 to sniff and thereby determine whether it is within the range of a base station. If so, the subscriber device registers with the base station 18, if not, the unlicensed wireless circuitry 114 is activated at a later time.

[0058] Under the control of the subscriber interface module 228, the base station 18 identifies the acknowledgement signal and transmits a subscriber device present signal to the router jack 202, the Ethernet jack 204, the phone line jack 208, or the phone extension jack 210. The subscriber device present signal is subsequently directed through a network (e.g., the LAN 28 and Internet 30) to the system server 24, which notes that the subscriber device 12 is now within the service area of the base station 18. In particular, the system server 24 logs this information in the location database 416.

[0059] Once the system server 24 logs the fact that the subscriber device 12 is within the service range of the base station 18, it contacts the cellular network 14 to initiate a call to the landline associated with the base station 18. It is known in the art to utilize a cellular network 14 to establish a call to a landline number. For example, FIG. 1 illustrates a link between the Mobile Switch Center (MSC) 26 and the PSTN 22. In the prior art, this feature is used to direct a call intended for a mobile device to a landline telephone when the user of the mobile device has advised the cellular system that the landline telephone can be used to receive calls. Observe in this situation that the transition from the cellular network to the landline telephone is established prior to the call being placed. This prior art scenario stands in sharp contrast to the present invention where during the course of an already established communication session control is transferred from a licensed wireless service to

an unlicensed wireless service or vice versa. This aspect of the invention is more fully appreciated in connection with the following discussion.

[0060] As previously indicated, when the subscriber device 12 crosses the boundary B3, a landline call to or from the base station 18 is initiated. Once the landline call is received at the base station 18, the base station 18 begins transmitting to the subscriber device 12 using the unlicensed wireless spectrum. These transmissions are processed by the unlicensed wireless circuitry 114 of the subscriber device 12 (See FIG. 2). At this point, the licensed wireless circuitry 118 is also active and the audio switch 108 is responsive to the licensed wireless circuitry 118. Thus, the subscriber device 12 is processing both licensed wireless signals and unlicensed wireless signals at this point. The handoff module 126 can coordinate this operation.

[0061] The subscriber interface module 228 of the base station 18 continues to monitor the signal strength from the subscriber device 12. When the signal strength reaches a threshold corresponding to the crossing of boundary B4, the subscriber interface module 228 initiates a handoff command, which is applied to the RF circuit 216. The handoff command is received at the subscriber device 12 and is processed by the handoff module 126, which generates a handoff signal that is applied to the audio switch 108. The handoff signal causes the audio switch 108 to process information from the audio circuitry 116 associated with the unlicensed wireless circuitry 114.

[0062] At this point, the licensed wireless circuitry 118 can be turned off. The ability to turn this circuitry off is a significant advantage because it preserves battery life. Typically, the licensed wireless circuitry remains active in order to provide location information to the licensed wireless system infrastructure. However, as discussed below, this location information is available in accordance with the invention. Therefore, the licensed wireless circuitry can be shut down to obtain a significant extension in battery life. Alternately, the licensed wireless circuitry 118 can remain in a low power state to receive signaling or messages from the licensed wireless system, while voice is carried over the unlicensed system.

[0063] The spacing between boundaries B3 and B4 allows time for the establishment of simultaneous connections between the subscriber device 12 and both the licensed network and unlicensed network. This allows for the immediate switching of service to the unlicensed network once the subscriber device 12 crosses boundary B4, thus creating a seamless transition to base station service that is transparent to the user.

[0064] Once the device 12 is within boundary B4, service is originated within the PSTN 20 and broadcast wirelessly to the device 12 by the base station 18. If the device 12 travels away from this base station 18, service is handed off from the base station 18 to a licensed wireless network 14 in a manner similar to the process described above. Specifically, once the device 12 crosses boundary B2, a simultaneous link is established with a licensed wireless network (e.g., cellular network 14). When the device 12 further crosses boundary B1, a seamless handoff is made from the unlicensed wireless service originating over the PSTN 20 to the licensed wireless network (e.g., cellular network 14). At this point, the subscriber device 12 receives wireless services from the cellular network 14 in a standard manner.

[0065] FIG. 7 provides a more detailed characterization of this handoff process from an unlicensed wireless service to a licensed wireless service. When the subscriber device 12 is within the service area 16 of the base station 18, the subscriber device 12 transmits to the base station 18 information on the signal strengths of the frequencies of the nearby licensed wireless base stations. The base station 18 forwards this information to the system server 24, which in turn sends the information to the Visitor Location Register (VLR) 32. This operation is shown with arrow 450 in FIG. 7.

[0066] In response to this message, the licensed wireless system provides the parameters that are needed when the subscriber device 12 needs a handoff from the unlicensed wireless system to the licensed wireless system. This information includes the identity of the base station to which the handoff should be made. By way of example, in a GSM cellular system, these parameters are CI (Cell Identity) and LAC (Location Area Code). This handoff information may be obtained and stored in the base station 18 before a call is made or when a call is made. In any event, the handoff information can be secured well before the subscriber device 12 roams outside the coverage area of the base station 18. The availability of this information allows the subscriber device 12 to quickly transition to the licensed wireless system. In addition, this information allows the licensed wireless circuitry 118 to be shut down for the purpose of extending battery life.

[0067] The licensed wireless system connection information may be delivered to the base station 18 via a landline connection as shown with line 452. Alternately, the information may be delivered through a communication session between the system server 24 and the mobile switch center 26 and then the system server 24 and the base station 18, as shown with arrows 454 and 456.

[0068] As shown with arrow 458 in FIG. 7, the base station 18 continuously makes power measurements of signals that are received from the subscriber device 12. When the power measurements begin to grow weak, the base station may notify the system server 24 to initiate a handoff to the licensed wireless system. In turn, the system server 24 may advise the Mobile Switch Center (MSC) 26 of the hand over candidate, as shown with arrows 460 and 462.

[0069] When the power measurements at the base station 18 become sufficiently weak, indicating that the subscriber device 12 is moving away from the base station 18 (e.g., crossing boundary B2) a formal hand over request is initiated. In particular, the base station 18 transmits to the system server 24 the base station identity (e.g., CI, LAC, etc.) to which the handoff should be transferred, as shown with arrow 458. The system server 24 contacts the MSC 26 to initiate a handoff, as shown with arrow 460. The MSC 26 contacts the Base Station Controller (BSC) 38, as shown with arrow 462. In response, the BSC 38 generates a channel number, a slot number and a handoff reference. As shown with arrow 464, this information is passed to the Base Station Transceiver System (BTS) 500. The information is also passed back to the subscriber device 12 through the MSC 26, the system server 24, and the base station 18, as shown with arrows 466, 468, 470, and 472.

[0070] In response to this information, the BTS 500 turns on a transmitter and receiver at the specified channel number and slot number. Similarly, the subscriber device 12 turns on its transceiver circuitry 118. The BTS 500 seeks a response from the subscriber device with a matching reference number, as shown with arrow 474. Once the subscriber device 12 receives the BTS transmission, it sends a message to the BTS with the handoff reference, as shown with arrow 476. At this point, a new licensed wireless link is established on the given channel and slot number, as shown with arrow 478. Once the licensed wireless link is established, the unlicensed wireless link is turned off, as shown with line 480 in FIG. 7. Thereafter, the BTS 500, the BSC 38, and the MSC 26 operate in a standard manner to supply licensed wireless services to the subscriber device 12. The foregoing operations may be implemented using the handoff module 126 of the subscriber device 12, the subscriber interface module 228 of the base station 18, and the system bridge programs 414 of the system server 24.

[0071] As previously indicated, a handoff from a licensed wireless service to an unlicensed wireless service occurs in a similar but reverse fashion. When the subscriber devices 12 cross boundary B3 from a remote location the base station 18 initiates a handoff operation

by sending a request to the system server 24, which conveys the request to the MSC 26. The MSC 26 then hands off the call to the landline number assigned to the base station 18.

[0072] Between boundaries B3 and B4, both the licensed wireless (e.g., cellular) link and unlicensed wireless (e.g., landline originated) link are simultaneously active. After a period in which both links are simultaneously active, control of the communication session is switched from the licensed wireless circuitry 118 to the unlicensed wireless circuitry 114. The handoff module 126 may coordinate this handoff in response to a handoff command initiated at the subscriber interface module 228 of the base station 18. As above, the maintenance of simultaneous licensed and unlicensed wireless links for a period of time ensures a successful seamless handoff. This reduces the number of dropped calls, and allows for successful handoffs even when the signaling messages among different elements of the cellular and landline-based systems experience delays or latency.

[0073] The foregoing discussion was directed toward handoffs between licensed wireless services and unlicensed wireless services. The invention also includes a technique for seamless handoffs between unlicensed wireless service base stations. Such a technique would be valuable, for example, in the case where an office building has a large number of base stations 18 to supply unlicensed wireless services to a user that would otherwise receive poor quality licensed wireless service within the office building.

[0074] Thus, the invention includes a system wherein a plurality of base stations 18 exist with overlapping coverage areas 16. This allows a subscriber device 12 to roam freely among the coverage areas 16.

[0075] FIG. 8 illustrates such a system. The subscriber device 12 is registered with base stations 18-1 and 18-2. Base stations 18-1 and 18-2 communicate with each other using LAN 28. The base stations 18-1 and 18-2 are shown installed in a typical workplace setting, with telephones 300 and PCs 302 connected to a LAN 28 and PBX 22 in a standard fashion. Note that the coverage areas 604 and 606 of the base stations 18-2 and 18-2 overlap. As a device 12 moves from one area 604 to another area 606, voice and data signals from the first base station 18-1 are seamlessly handed off to the second base station 18-2.

[0076] Periodically, the base stations 18-1 and 18-2 broadcast a message over the LAN 28 to all other base stations connected to the LAN 28. This message includes a time stamp, a signal indicating the particular base station, the subscriber number, and a range number indicating the distance between that base station and the device 12. A separate message is

broadcast for each base station on the LAN 28. A range number can be calculated by relying upon the ability of the base station 18 to measure the signal strengths emitted from the subscriber device or vice versa.

[0077] In accordance with this feature of the invention, there is no centralized control mechanism for handling handoffs. Instead, the subscriber interface module 228 of each base station 18 is used to coordinate handoffs between base stations based upon signal strengths and/or range numbers. For example, in Figure 8, at position T1 the base station 18-1 would transmit a time stamp, a base station number, a subscriber number, and a range number indicating that the subscriber device 12 is relatively close to the base station 18-1. At T2 the base station 18-1 would transmit the same information except a different range number indicating that the signal between the base station 18-1 and the subscriber device 12 is weaker. By position T3, the base station 18-2 would send a signal on the LAN 28 indicating that it has a range number indicating that the subscriber device 12 is now closer to it than to base station 18-1. Accordingly, both base stations would recognize that a transition from base station 18-1 to base station 18-2 should transpire. Under these circumstances, the second base station 18-2 transmits a signal over LAN 28 to the first base station 18-1 requesting a transition. Once the first base station 18-1 acknowledges this request, it forwards the call to the second base station 18-2 and service is continued without disruption. For example, the call may be forwarded over LAN 28 using Voice Over Internet Protocol (VOIP) techniques.

[0078] The discussion up to this point has been directed toward seamless transitions between licensed and unlicensed wireless services. Attention now turns to other aspects of the invention. Another aspect of the invention is a technique for assigning a base station to a landline telephone number. Another aspect of the invention is a technique for authenticating a user for unlicensed wireless services. Advantageously, authentication is implemented through reliance upon existing authentication infrastructure associated with the licensed wireless network. Thus, a separate authentication scheme need not be implemented. Another aspect of the invention that is discussed below is the provisioning of a base station into the overall licensed wireless network. As discussed below, the provisioning operation is automatically performed and therefore does not require technical sophistication or expertise on behalf of the user.

[0079] FIG. 9 illustrates a technique for assigning a landline number to a base station 18. Upon installation and power-up, the base station 18 queries the subscriber device 12 for the

local landline phone number to which the base station is connected. In some embodiments, the base station 12 will also solicit the Internet Protocol (IP) address for the system server 24. After the user enters the phone number and/or IP address into the subscriber device 12, the information is transmitted to the base station 18, as shown with arrow 610 of FIG. 9. The base station 18 forwards the same information to the system server 24, as shown with arrow 612. The system server 24 then transmits this information for storage in the HLR 34, as shown with arrow 614. Once stored in the HLR 34, the MSC 26 can access the number as a mobile system roaming number (MSRN), as shown with arrows 616 and 618. Thereafter, the mobile system roaming number can be used in a conventional manner to route a call to the base station 18. Alternately, the MSRN may be a number corresponding to a number associated with the system server 24. In which case, the system server 24 sends the call to the base station 18.

[0080] Another aspect of the invention is authentication. As previously indicated, the invention utilizes the authentication infrastructure associated with the licensed wireless network to authenticate users for the unlicensed wireless network.

[0081] FIG. 10 illustrates a licensed wireless system authentication process utilized in accordance with the prior art. In this example, the subscriber device 12 moves from the coverage area served by its home MSC (referred to as MSC-A) to the coverage area served by MSC-B. As soon as the subscriber device 12 enters a cell that is served by MSC-B, it registers with the system by sending an authentication request and a location update to Base Station System (BSS) 600, as shown with arrow 650. The location update request includes an international mobile subscriber identity (IMSI).

[0082] BSS 600 forwards this information to the VLR 32 associated with MSC-B, as shown with arrow 652. The VLR of MSC-B in turn sends a message to the VLR and HLR of the MSC-A, as shown with arrows 654 and 656. This information serves as a request for authentication of the subscriber device 12 as well as to inform the HLR 34 of the current location of the subscriber device 12 as served by the MSC-B. The authentication is performed as follows.

[0083] The authentication center (AuC) 36 generates a parameter called SRES (signed response). In order to generate the SRES, it uses an authentication algorithm A3, such as a public key/private key algorithm. The algorithm A3 processes a secret key K_i , a random number RAND, and the IMSI to produce the SRES. The IMSI, RAND, and SRES are passed to the MSC-A (arrow 658) and MSC-B (arrow 660). The SRES is temporarily

stored at the MSC-B until the authentication operation is completed. The MSC-B passes the IMSI and the RAND to the BSS, which passes the information to the subscriber device 12. Based upon the IMSI and the RAND that it receives (referred to herein as licensed wireless communication system security information), along with the secret key Ki that it stores, the subscriber device 12 executes the same authentication algorithm A3. This results in the subscriber device 12 producing a SRES, which is referred to as an authentication result. If the subscriber device is legitimate, it has the same secret key Ki encoded in it as the one in the HLR. The service provider encodes this key at the time of activating the subscriber. This key is known only to the subscriber device and to the HLR.

[0084] The SRES, or authentication result, generated by the subscriber device 12 is passed with the IMSI to the BSS-B (arrow 666), which passes it to the MSC-B (arrow 668). The MSC-B compares the SRES generated by the subscriber device 12 to the SRES generated by the HLR. Authentication is only successful if the two numbers match. The SRES generated by the HLR can be referred to as an authentication value. If the authentication value from the HLR matches the authentication result from the subscriber device 12, then an authentication command is generated.

[0085] The above process assists in understanding the authentication process included in the present invention, as the new method is designed to utilize the existing authentication process already existent in the licensed wireless system. FIG. 11 illustrates an authentication process in accordance with the present invention. In accordance with the invention, the base station 18 is designed to emulate a BSS 600, and the system server 24 is designed to emulate an MSC 26.

[0086] When the subscriber device 12 enters the service area of the base station 18, it registers with the base station. The authentication module 124 of the subscriber device 12 subsequently intercepts the registration message that is typically sent to the licensed wireless base station (e.g., BSS 600). This information, referred to as a licensed wireless authentication request, is sent to the base station 18, as shown with arrow 680. The base station 18, at the direction of the authentication module 230, routes the information to the system server 24. In particular, the authentication module 230 of the base station 18 forms an Internet Protocol (IP) packet containing the information and routes it to the system server 24. As shown with arrow 684, the system server 24 forwards the information to the MSC-A. The authentication module 422 of the system server 24 may be used for this purpose. In this capacity, the authentication module 44 assists the system server 24 in its operation of

emulating a VLR. The operations at arrows 656, 658, and 660 are identical to the operations performed in the prior art system of FIG. 10.

[0087] At this point, the system server 24 stores the SRES, instead of an MSC. The system server 24 forwards the IMSI and RAND information to the base station 18, as shown with arrow 686. The base station 18, emulating a BSS, passes this information to the subscriber device 12. The authentication operation performed at the subscriber device is conventional, with the subscriber device returning an authentication result (e.g., an IMSI and a SRES) to the base station 18, as shown with arrow 690. The base station 18 passes this information to the system server 24, as shown with arrow 692. The system server 24 then checks for an SRES match. That is, the system server compares the authentication result produced by the subscriber device 12 to the authentication value (e.g., SRES) received from the MSC-A. Recall that this operation was performed by the MSC 26 in the prior art system of Figure 10. In the event of a match between the computed SRES values, an authentication command is produced and unlicensed wireless services may be delivered to the subscriber device 12 through the base station 18.

[0088] Preferably, authentication is not performed every time the subscriber device registers with the base station 18. Instead, the authentication module 230 of the base station 18 preferably stores previous authentication information and locally re-authenticates without accessing the system server 24. This implementation is faster and otherwise reduces network traffic.

[0089] Yet another aspect of the invention involves provisioning of a base station in order to facilitate the licensed-to-unlicensed wireless communications achieved in accordance with the invention. By way of overview, the provisioning operation of the invention entails the base station 18 automatically configuring itself. In one embodiment, provisioning is accomplished by initially accessing a provisioning server. Subsequently, the base station registers with the system server. In the event that Internet access is available to the base station, the base station uses the Internet to access the provisioning server and the system server. If Internet access is not available, a Short Message Service Center may be used during the provisioning operation.

[0090] FIG. 12 illustrates equipment utilized during the provisioning operation. In particular, the figure illustrates a subscriber device 12 and a base station 18. In one embodiment, the base station 18 uses the Internet 30 to access a provisioning server 700. For example, the base station 18 may access the Internet through a broadband modem, such

as DSL. The provisioning server 700 supplies a service profile to the system server 24, as discussed more fully below. In another embodiment of the invention, the base station 18 is provisioned through a wireless connection. In particular, a wireless link is established using a Short Messaging Service or packet data services supported by the cellular system. For example, a short messaging service message can be sent from the base station 18 to the subscriber device 12, which then delivers the message to the BSS 600. The BSS 600 delivers the message to the cellular network 14, which delivers the message to the MSC 26. The MSC 26 routes the message to the Short Message Service Center (SMSC) 702, which routes the message over the Internet 30 to the provisioning server 700. Information from the provisioning server 700 is delivered to the system server 24 and the base station 18 through a reverse path.

[0091] FIG. 13 illustrates the process steps involved when the system of FIG. 12 carries out the provisioning process. The process is typically initiated upon installation and activation of a new base station 18, and will be discussed in that context, but those of skill in the art will see that it can be performed any time that provisioning information must be updated.

[0092] When a base station 18 is initially powered up it contacts the provisioning server 700 (step 800). The provisioning module 226 of the base station 18 coordinates this operation. In one embodiment, contact is made through the Internet 30 using one or more preprogrammed IP addresses for the provisioning server. Alternately, the provisioning server may be accessed through the SMSC, as discussed above. The base station 18 then identifies itself to the provisioning server 700, for example, using a code preprogrammed at the time of manufacture. If the provisioning server 700 does not recognize the base station, the base station preferably provides an error indication. If the provisioning server 700 recognizes the base station, that processing proceeds to block 806.

[0093] At this point, the base station broadcasts a signal to the subscriber device 12 instructing it to define itself (block 806). For example, the subscriber device 12 may define itself by sending to the base station 18 an electronic serial number or a portion of an electronic serial number. This defining information is used to establish an association between the base station 18 and the subscriber device 12. This local association is mapped with a local authentication procedure. Thereafter, whenever the subscriber device and the base station come into contact, they identify each other by passing the local authentication procedure. The two devices can only communicate if the local authentication procedure is successful.

[0094] The provisioning module 127 of the subscriber device 12 prompts the user to enter the landline telephone number associated with the base station 18 (block 808). This information is then passed to the base station 18. The base station then delivers information to the provisioning server (block 810). For example, the base station will typically deliver the landline telephone number and a base station identification number to the provisioning server. The provisioning server then downloads a service profile to the base station and the system server (block 812). The service profile can include the landline telephone number and caller services, such as call waiting, caller identification, and the like. The service profile may also include an IP address for the base station. The IP address allows packet data to be delivered to the base station. The service profile also includes the IP address of a system server 24 assigned to the base station 18. Typically, the system server 24 is selected based upon proximity to the base station, as derived from the area code associated with the landline telephone number.

[0095] Observe that the provisioning server operates as a central registration point for all devices within the system. This central point makes it easier to modify system wide services. In addition, the provisioning server provides the benefit that a single address is programmed into each base station.

[0096] The base station takes the IP address of the system server from the service profile and contacts the system server (block 814). If the service profiles match, an association is established between the system server, the base station, and the subscriber device. The system server subsequently updates the HLR of the subscriber device with contents of the service profile (block 816). At this point, the authentication process of FIG. 11 would typically be performed. This provisioning process can be repeated whenever a new device 12 or base station 18 is introduced into the system.

[0097] Another aspect of the invention allows licensed wireless service users to seamlessly change between a desktop phone and a subscriber device 12 during a call, thus allowing them to use the most comfortable device at a given time. Thus, when a subscriber device 12 is located within a coverage area 16, a user can simply pick up the desktop phone and continue their conversation. The subscriber device 12 can then be disconnected without any interruption in service. In this embodiment, the desktop phone and the base station are connected to the same landline, thereby providing this interchangeability. Likewise, when a caller is using a desktop phone within an area 16, he or she can activate a subscriber device 12 and continue a call from there. In this instance, a button on the subscriber device is used

to initiate communication with the base station that is connected to same landline. Subsequently hanging up the desktop phone will not interrupt service. Observe in this context that when the subscriber device is within the coverage area 16 of the base station 18, both the subscriber device 12 and a desktop telephone may simultaneously ring in response to a call. The user can then pick up either device.

[0098] The foregoing description, for purposes of explanation, used specific nomenclature to provide a through understanding of the invention. However, it will be apparent to one skilled in the art that specific details are not required in order to practice the invention. Thus, the foregoing descriptions of specific embodiments of the invention are presented for purposes of illustration and description. They are not intended to be exhaustive or to limit the invention to the precise forms disclosed; obviously, many modifications and variations are possible in view of the above teachings. The embodiments were chosen and described in order to best explain the principles of the invention and its practical applications, the thereby enable other skilled in the art to best utilize the invention and various embodiments with various modifications as are suited to the particular use contemplated. It is intended that the following claims and their equivalents define the scope of the invention.

In the claims:

1. A method of integrating a licensed wireless system and an unlicensed wireless system, comprising:
 - initiating a wireless communication session in a first region serviced by a first wireless system; and
 - maintaining said wireless communication session in a second region serviced by a second wireless system, wherein said first wireless system is selected from the group including a licensed wireless system and an unlicensed wireless system, and said second wireless system is the unselected system from said group including said licensed wireless system and said unlicensed wireless system.
2. The method of claim 1 wherein said maintaining includes coordinating the operation of said unlicensed wireless system and said licensed wireless system so as to support said wireless communication session over a transition from said first region to said second region.
3. The method of claim 1 wherein maintaining includes simultaneously maintaining connections with said first wireless system and said second wireless system prior to establishing a final connection with either said first wireless system or said second wireless system.
4. The method of claim 1 wherein said maintaining extends the coverage area of said licensed wireless system to include said unlicensed wireless system.
5. The method of claim 1 further comprising aggregating two or more cells in said unlicensed wireless system to appear as a single cell to said licensed wireless system.
6. A method of integrating a licensed wireless system and an unlicensed wireless system, comprising:
 - establishing a communication session through a landline;
 - linking said communication session to a subscriber device through an unlicensed wireless system servicing an unlicensed wireless system service area;

receiving an indication that said subscriber device is moving from said unlicensed wireless system service area into a licensed wireless system service area; and

without disrupting said communication session, automatically transitioning said communication session from said unlicensed wireless system to a licensed wireless system servicing said licensed wireless system service area.

7. The method of claim 6 further comprising:

delivering licensed wireless communication system security information to said subscriber device;

processing an authentication result produced by said subscriber device;

comparing said authentication result with an authentication value to selectively produce an authentication command; and

enabling unlicensed wireless communications between said subscriber device and an unlicensed wireless communication system in response to said authentication command.

8. A method of provisioning an unlicensed wireless communication base station for interoperability with a licensed wireless communication system, comprising:

receiving at a provisioning server unlicensed wireless communication system information;

downloading a service profile from said provisioning server to an unlicensed wireless communication base station; and

establishing contact between said unlicensed wireless communication base station and a system server based upon said service profile.

9. A wireless communication handset, comprising:

licensed wireless communication signal processing circuitry;

unlicensed wireless communication signal processing circuitry; and

a control circuit connected to said licensed wireless communication signal processing circuitry and said unlicensed wireless communication signal processing circuitry, said control circuit transitioning a communication session without interruption between said licensed wireless communication signal processing circuitry and said unlicensed wireless communication signal processing circuitry.

10. An unlicensed wireless communication base station, comprising:
 - a radio frequency circuit to receive a transition signal indicative of a subscriber device entering or leaving a service region of an unlicensed wireless communication base station;
 - network interface circuitry; and
 - a control circuit connected to said radio frequency circuit and said network interface circuitry, said control circuit routing a subscriber device position transition signal to said network interface circuitry in response to said transition signal.

11. A server for integrating an unlicensed wireless communication system and a licensed wireless communication system, comprising:
 - a network interface card;
 - a licensed wireless network interface card;
 - a processor connected to said network interface card and said licensed wireless network interface card; and
 - a memory connected to said processor, said memory storing
 - instructions to identify when a subscriber device is entering or leaving a service region of a selected unlicensed wireless communication base station, and
 - instructions to transfer the routing of a current communication session between a licensed wireless communication system and said selected unlicensed wireless communication base station.

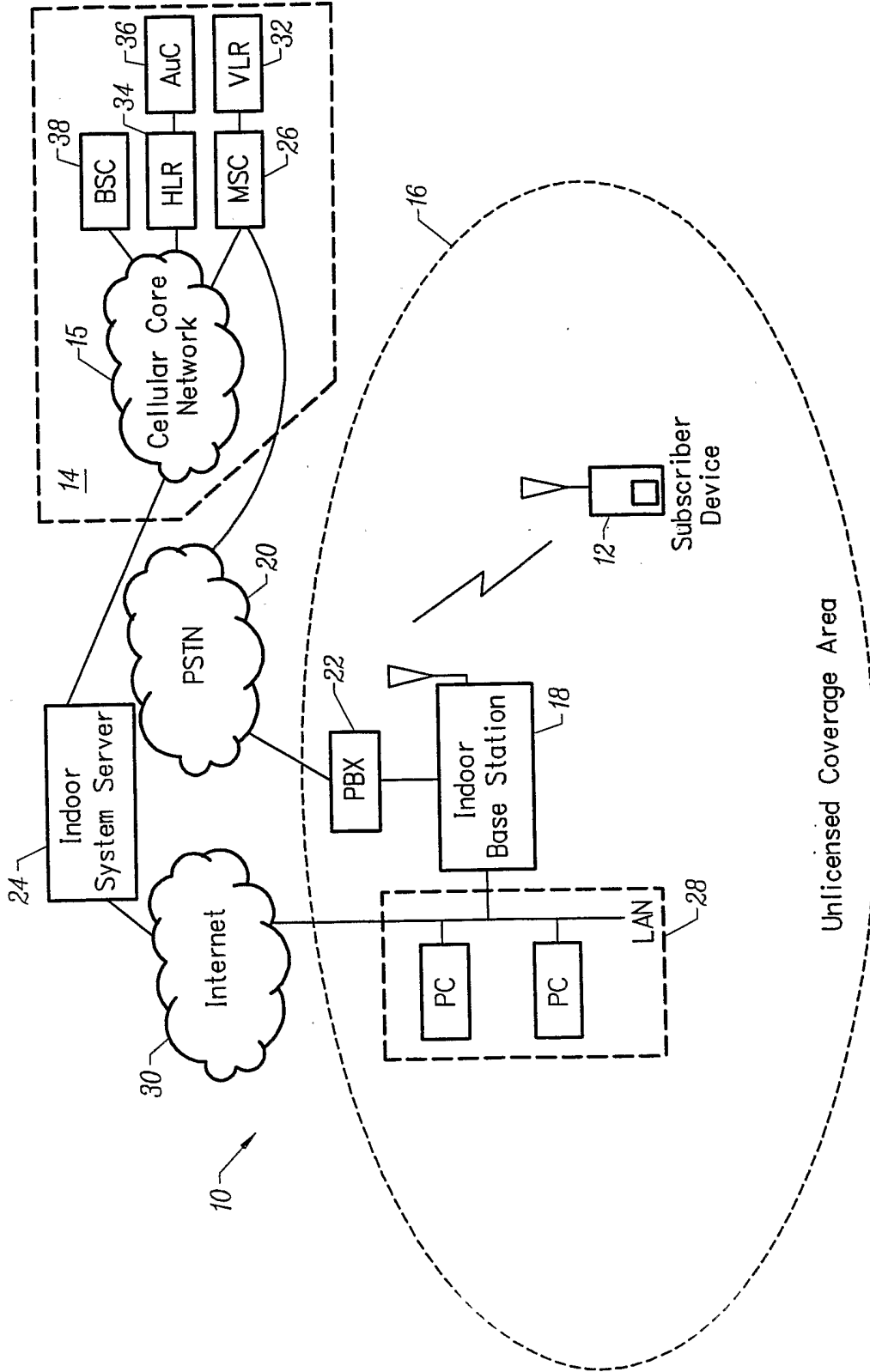

FIG. 1

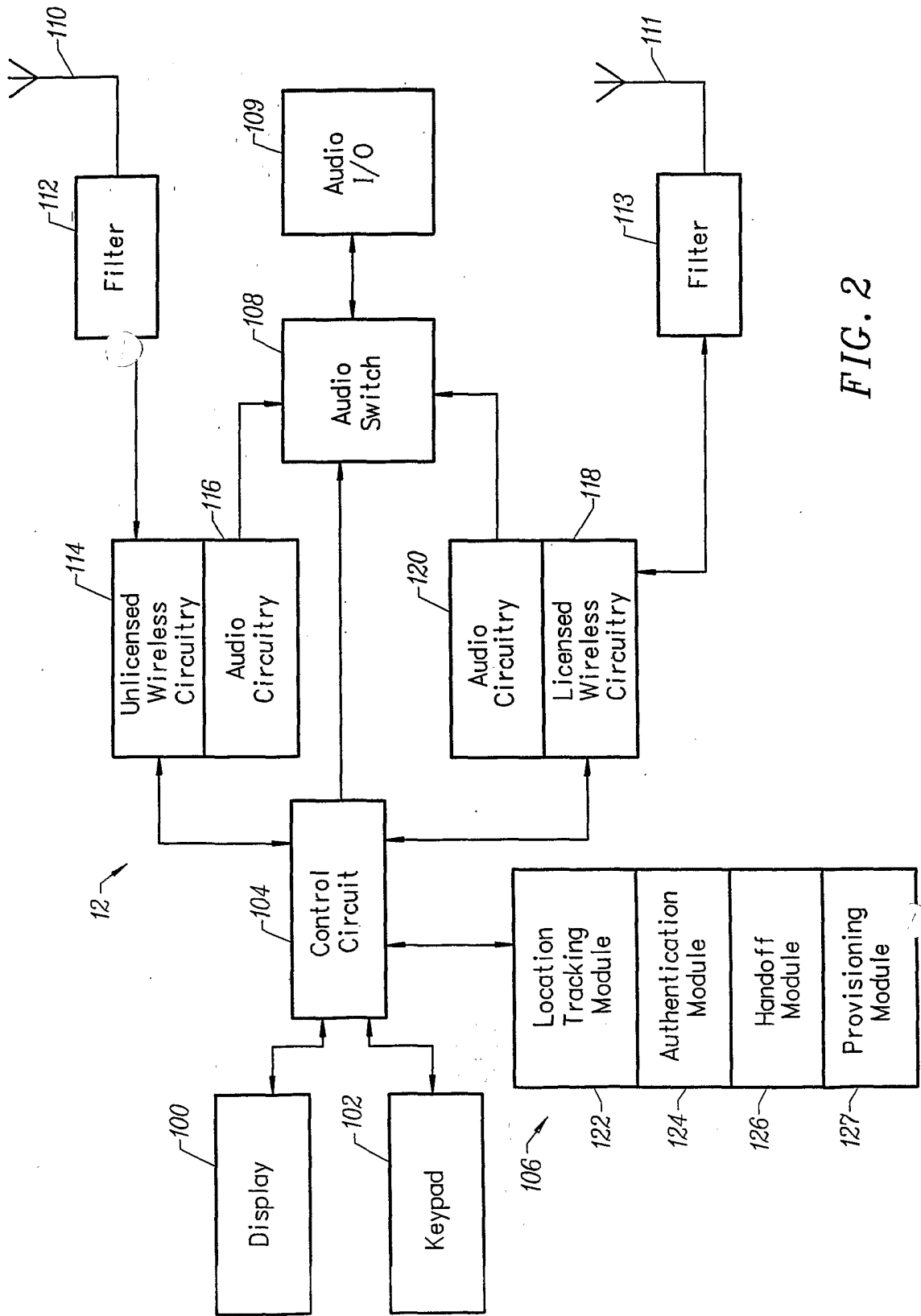

FIG. 2

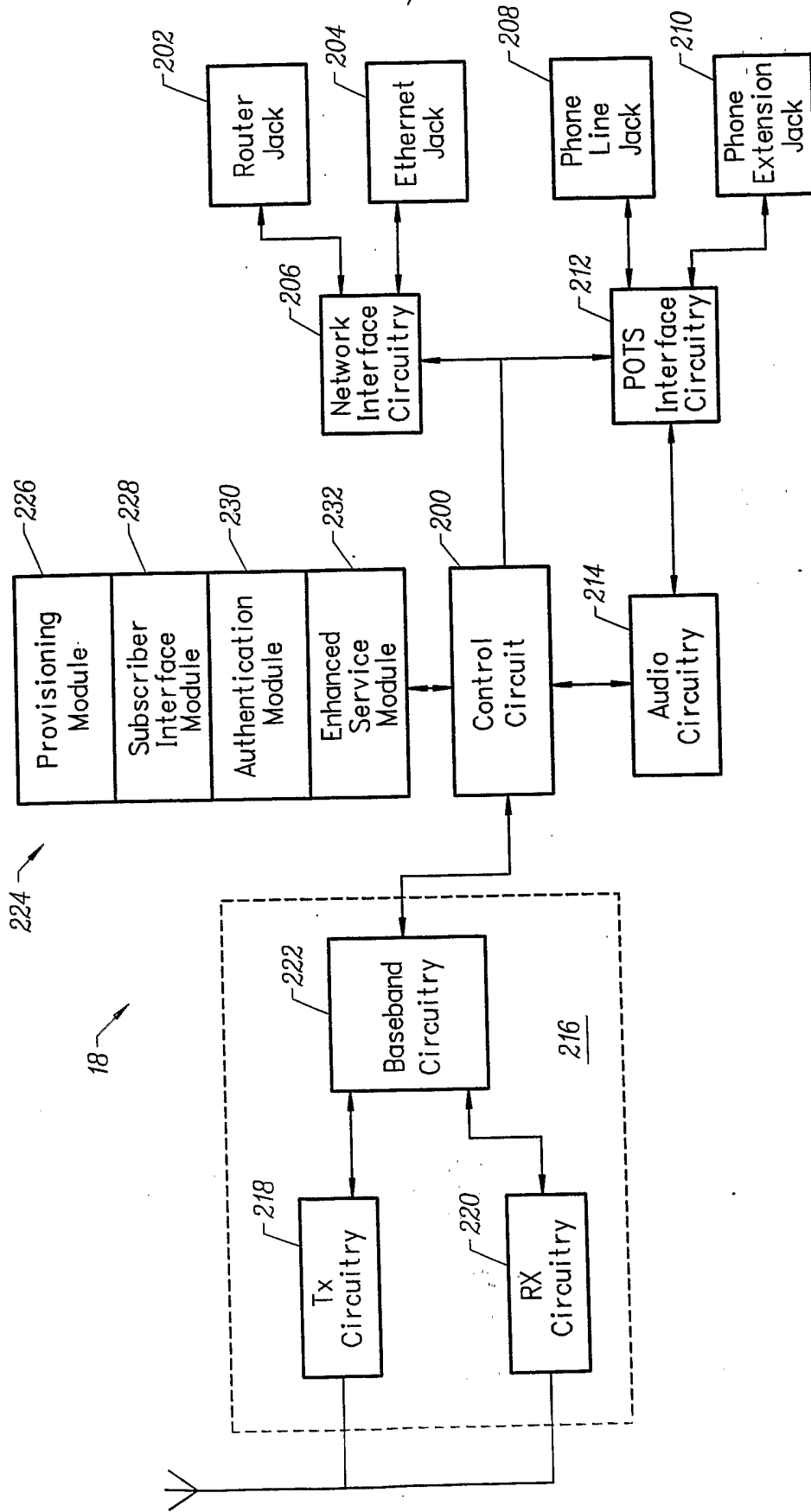

FIG. 3

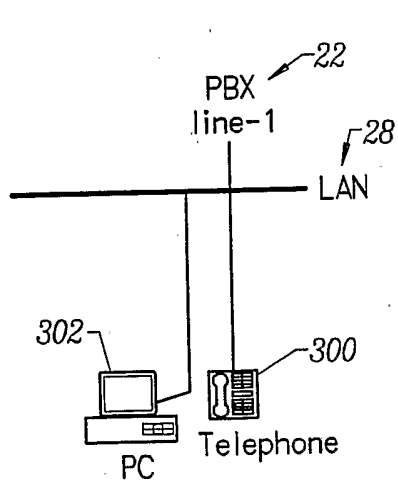

FIG. 4A

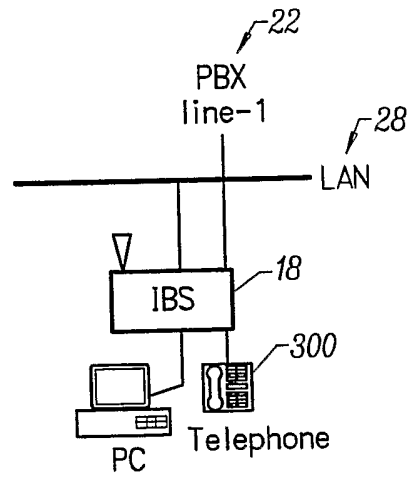

FIG. 4B

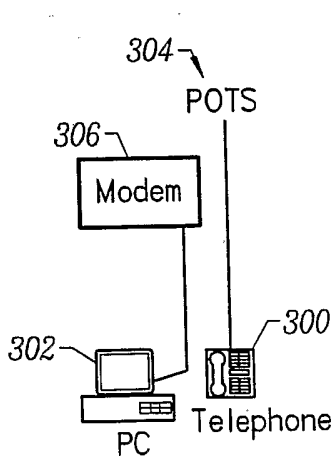

FIG. 4C

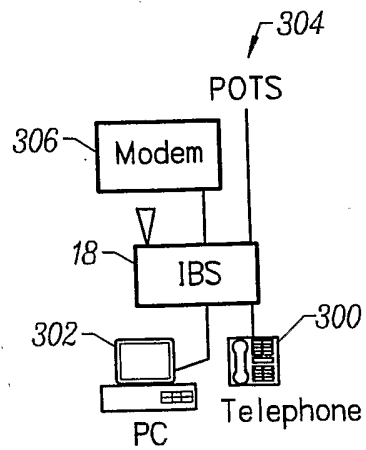
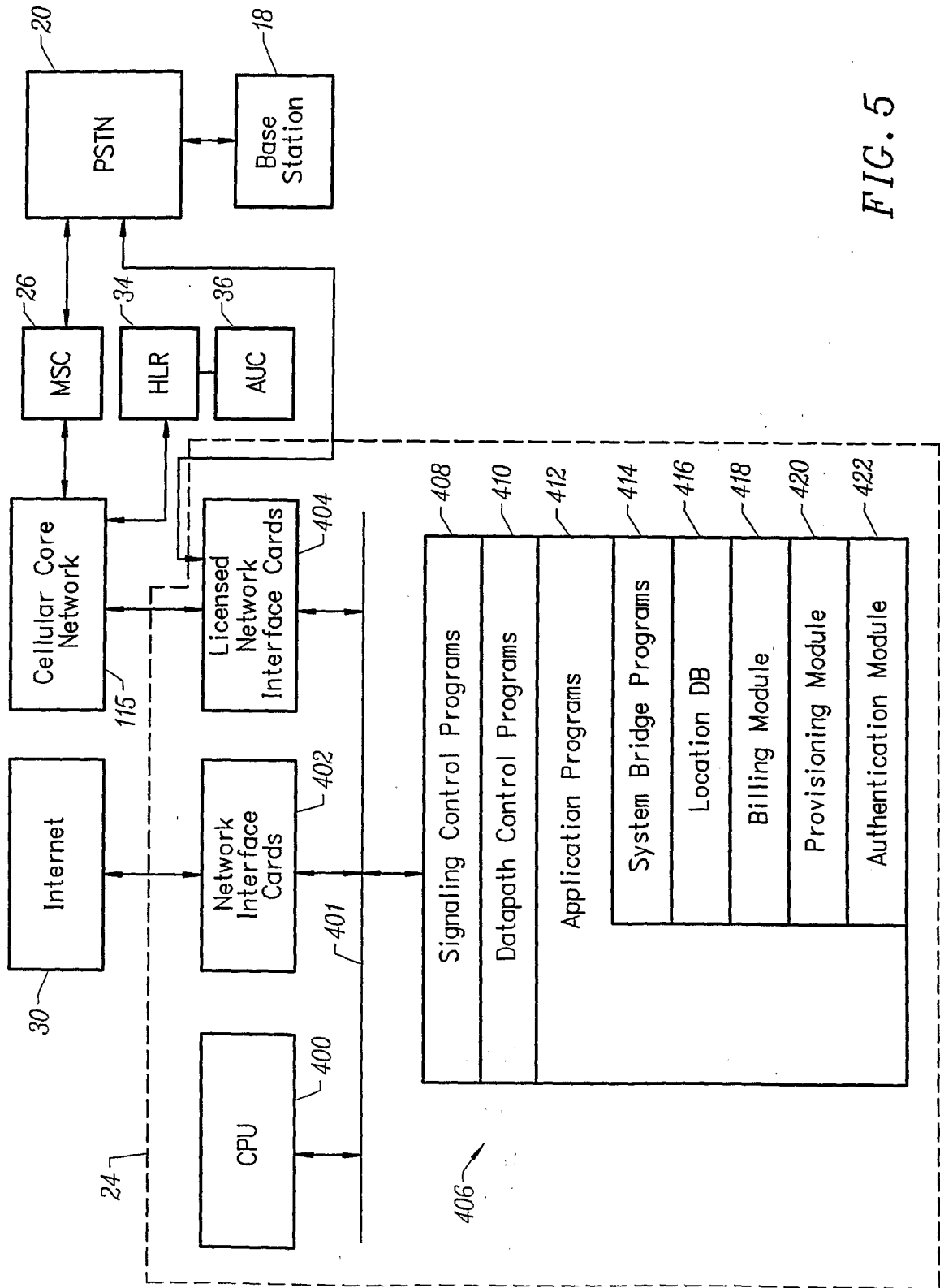

FIG. 4D



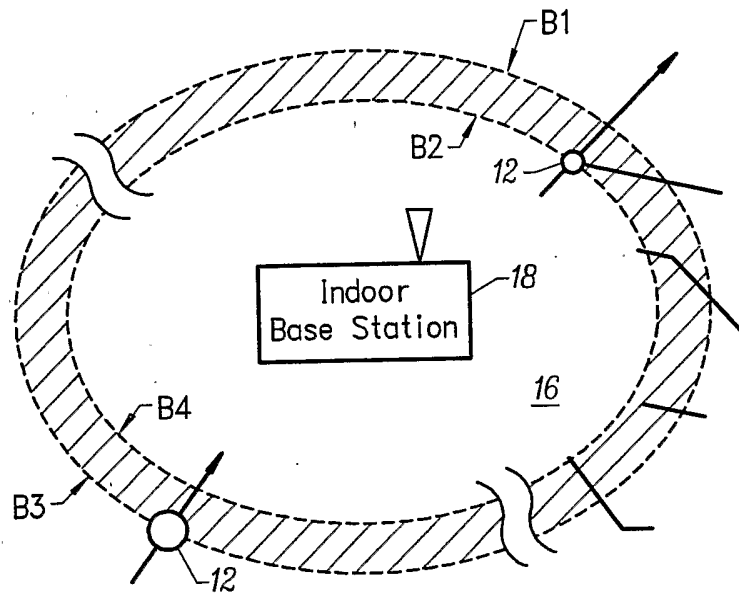

FIG. 6

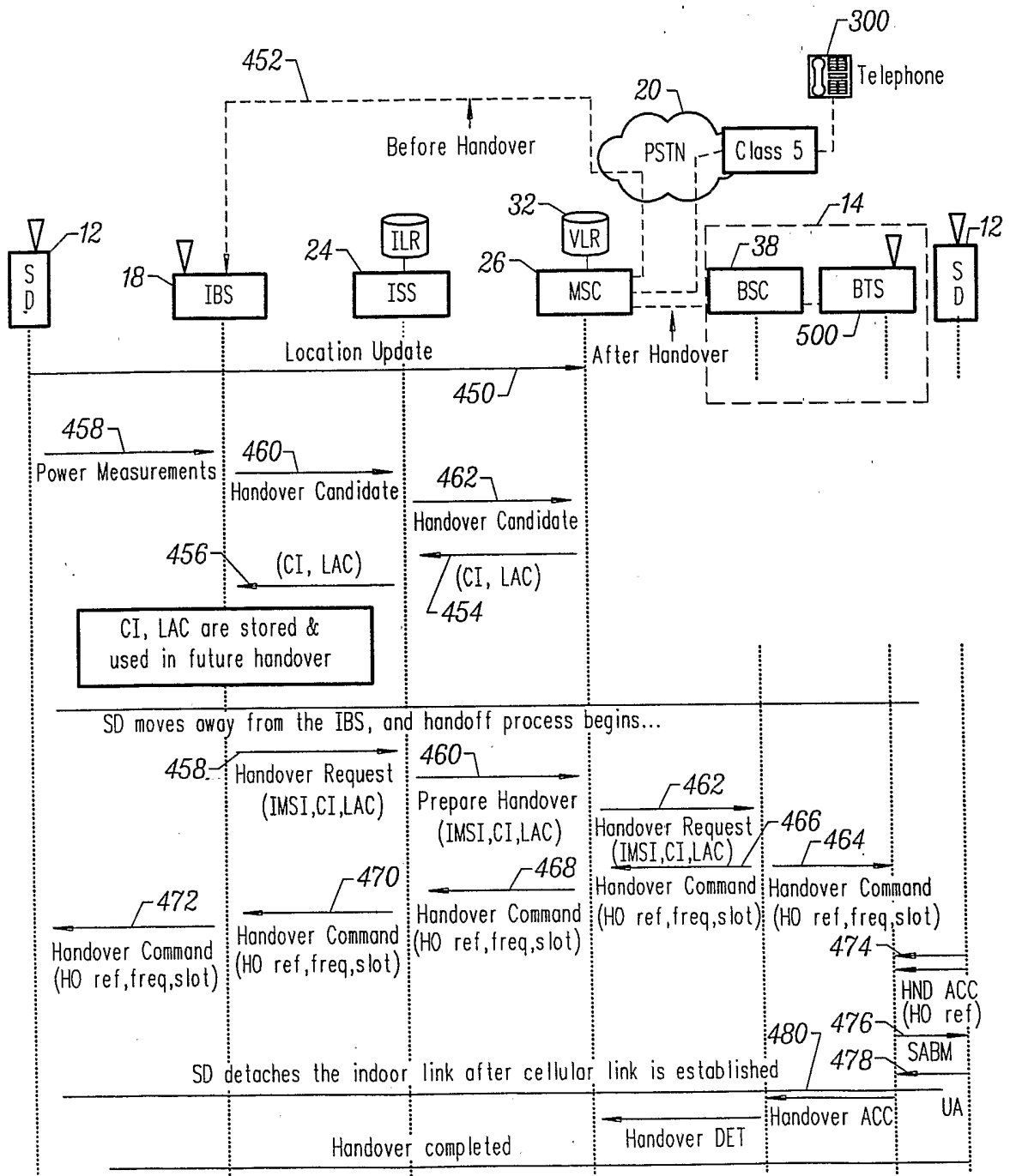

FIG. 7

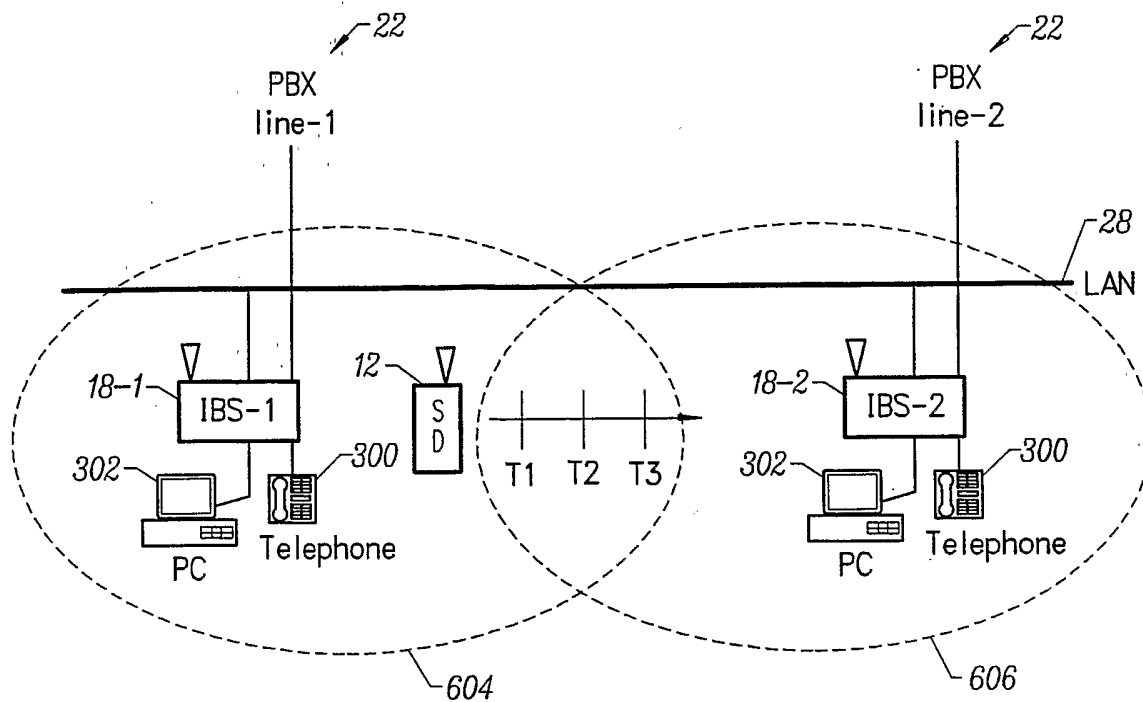

FIG. 8

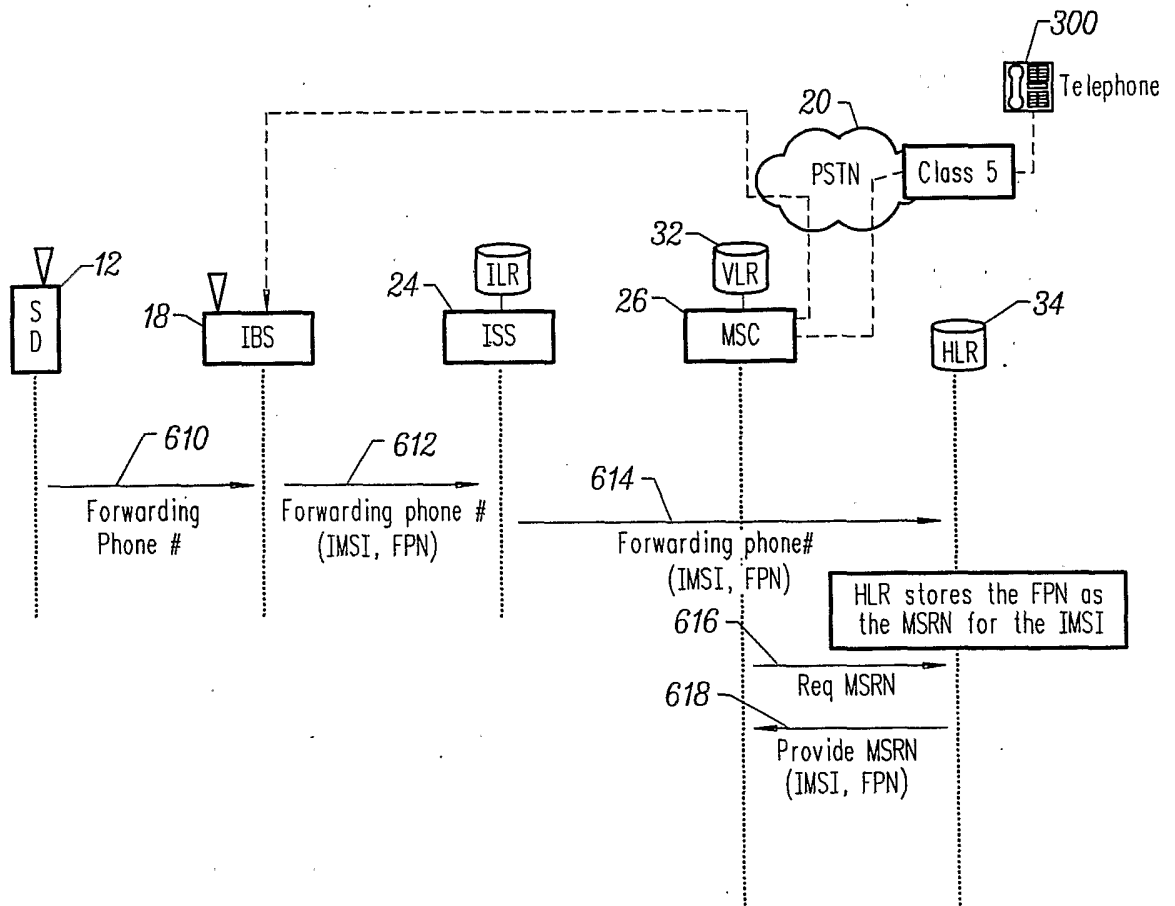

FIG. 9

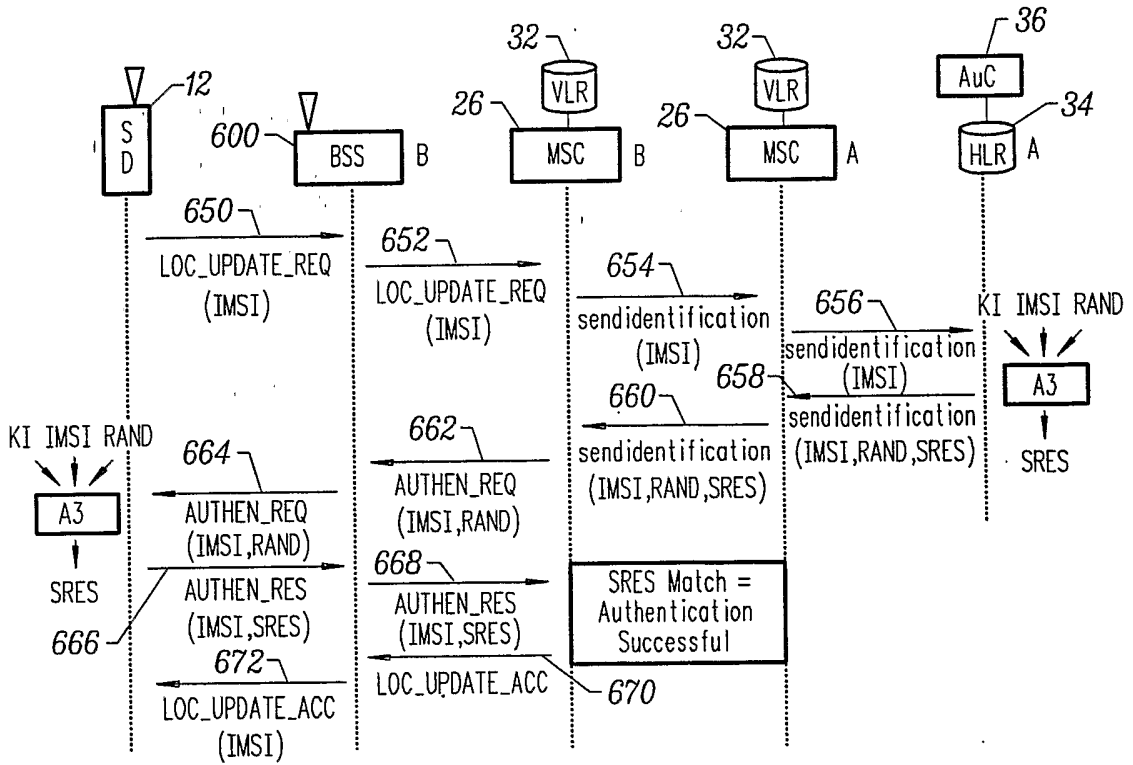

FIG. 10
(Prior Art)

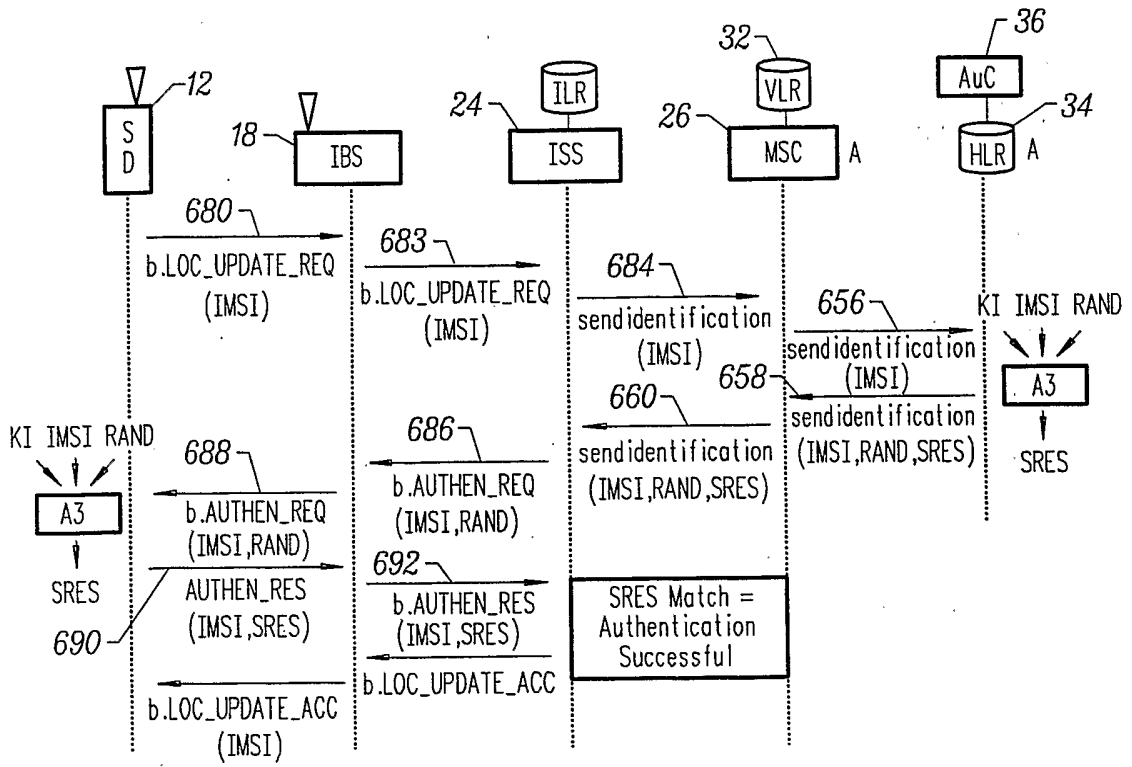

FIG. 11

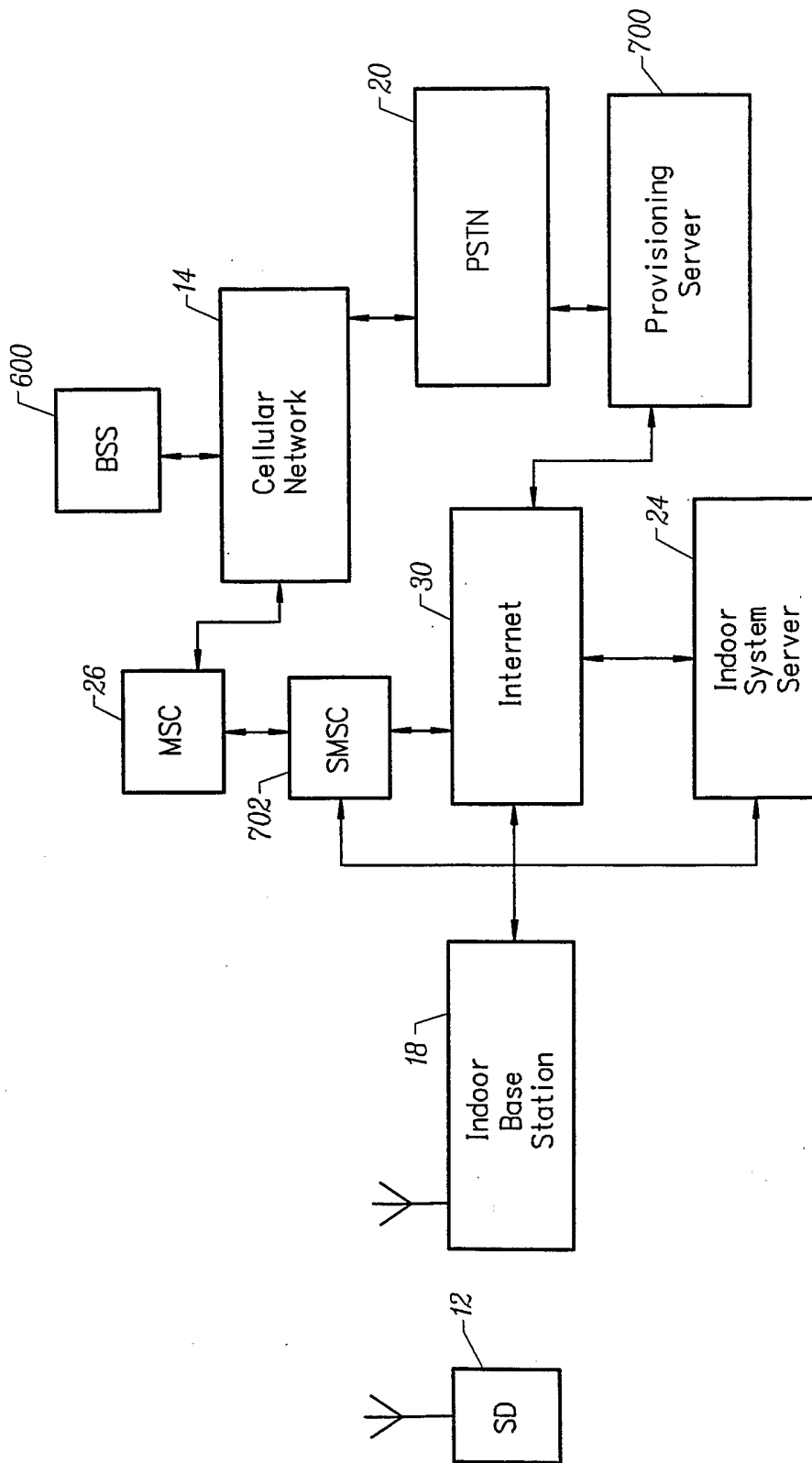

FIG. 12

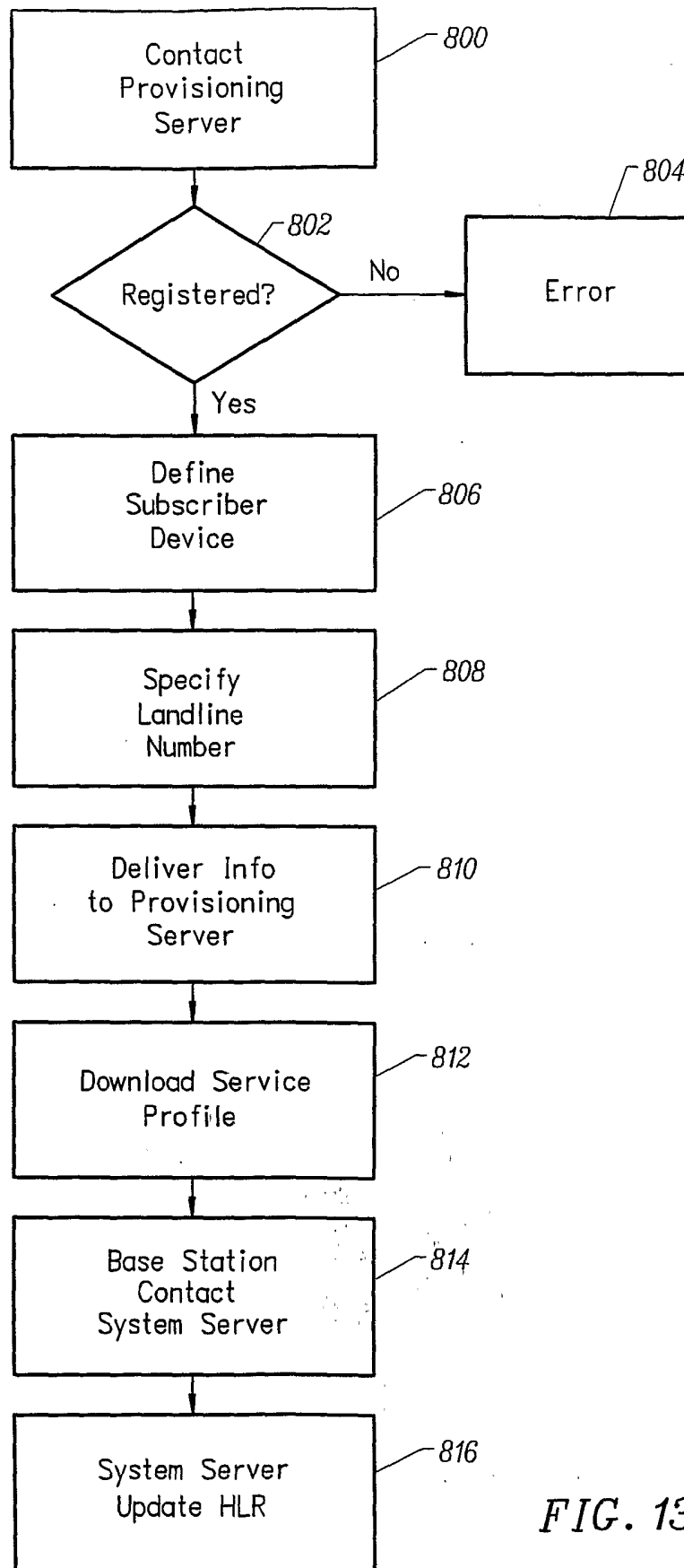

FIG. 13

INTERNATIONAL SEARCH REPORT

International application No.

PCT/US03/04485

A. CLASSIFICATION OF SUBJECT MATTER IPC(7) : H04Q 7/20; H04M 1/66,68 3/16; H04B 1/38 US CL : 455/426,462,465,436,442,410,411,552,553 According to International Patent Classification (IPC) or to both national classification and IPC		
B. FIELDS SEARCHED Minimum documentation searched (classification system followed by classification symbols) U.S. : 455/426,462,465,436,442,410,411,552,553 Documentation searched other than minimum documentation to the extent that such documents are included in the fields searched Electronic data base consulted during the international search (name of data base and, where practicable, search terms used) EAST		
C. DOCUMENTS CONSIDERED TO BE RELEVANT		
Category *	Citation of document, with indication, where appropriate, of the relevant passages	Relevant to claim No.
X	US 5,406,615 A (MILLER,II et al) 11 April 1995 (11.04.1995), figure 1, 3 and 4-9 , column 1 and lines46-65, column 2 and lines19-30, column 3 and line 40-column 4 and line 14, column 7 and line14-column 8 and line 20)	1-4, 6-11
X	US 2001/0029186 A1 (CANYON et al) 11 October 2001 (11.10.2001), figure 3, column 1 and paragraph 8 and 9)	5
<input type="checkbox"/> Further documents are listed in the continuation of Box C. <input type="checkbox"/> See patent family annex.		
* Special categories of cited documents:		
"A"	document defining the general state of the art which is not considered to be of particular relevance	"T" later document published after the international filing date or priority date and not in conflict with the application but cited to understand the principle or theory underlying the invention
"E"	earlier application or patent published on or after the international filing date	"X" document of particular relevance; the claimed invention cannot be considered novel or cannot be considered to involve an inventive step when the document is taken alone
"L"	document which may throw doubts on priority claim(s) or which is cited to establish the publication date of another citation or other special reason (as specified)	"Y" document of particular relevance; the claimed invention cannot be considered to involve an inventive step when the document is combined with one or more other such documents, such combination being obvious to a person skilled in the art
"O"	document referring to an oral disclosure, use, exhibition or other means	"&" document member of the same patent family
"P"	document published prior to the international filing date but later than the priority date claimed	
Date of the actual completion of the international search		Date of mailing of the international search report
14 April 2003 (14.04.2003)		20 MAY 2003
Name and mailing address of the ISA/US Commissioner of Patents and Trademarks Box PCT Washington, D.C. 20231 Facsimile No. (703)305-3230		Authorized officer Yuwen Pan Telephone No. 703-306-0377