

Feb. 22, 1949.

H. KUPPIN
HOBBY HORSE

2,462,648

Filed Feb. 6, 1946

2 Sheets-Sheet 1

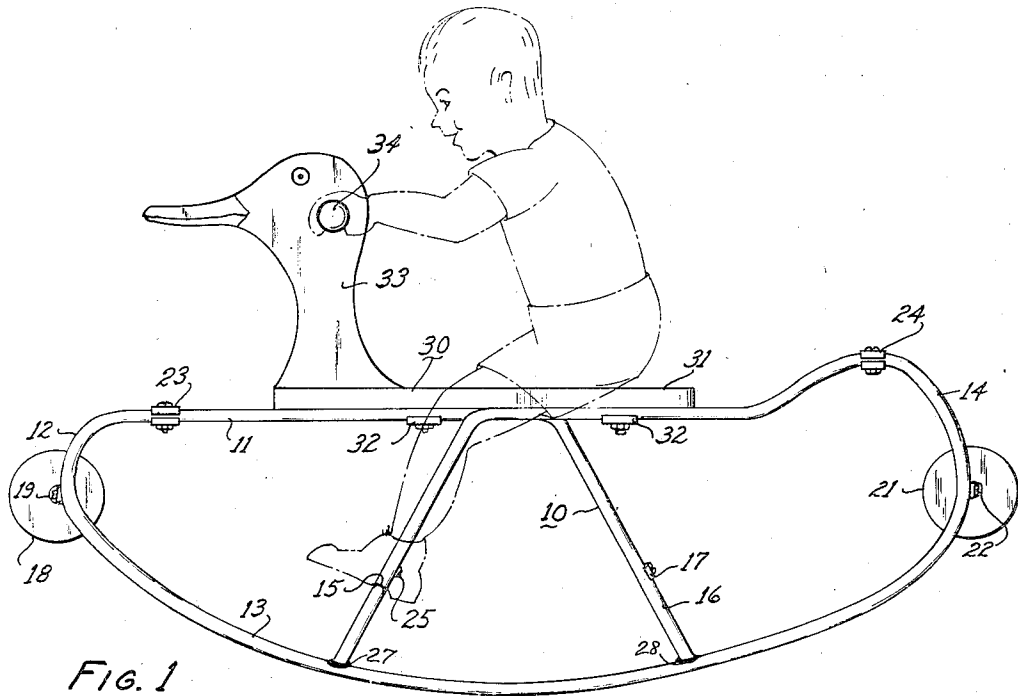

FIG. 1

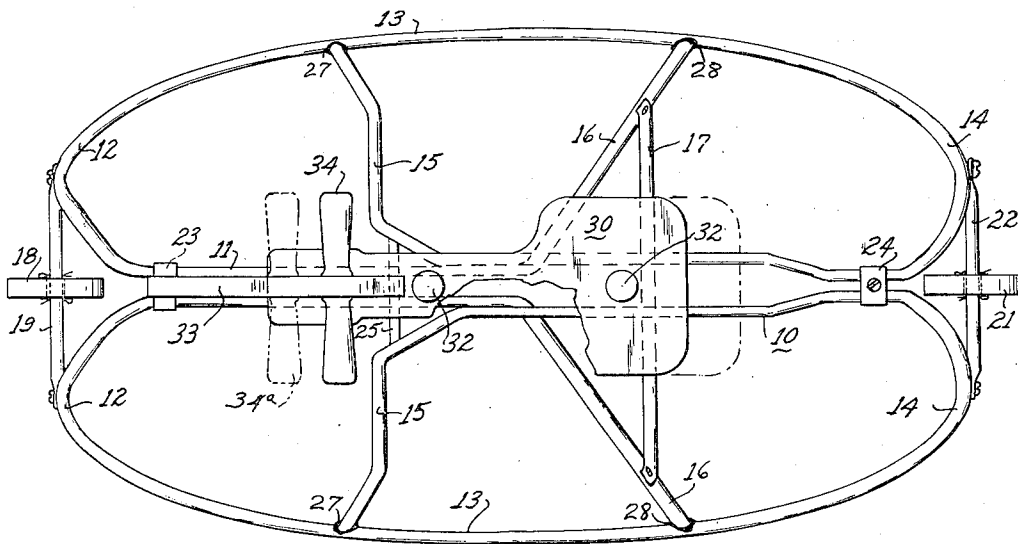

FIG. 2

INVENTOR.

HERBERT KUPPIN

BY

Victor S. Brockman

ATTORNEY.

Feb. 22, 1949.

H. KUPPIN

2,462,648

HOBBY HORSE

Filed Feb. 6, 1946

2 Sheets-Sheet 2

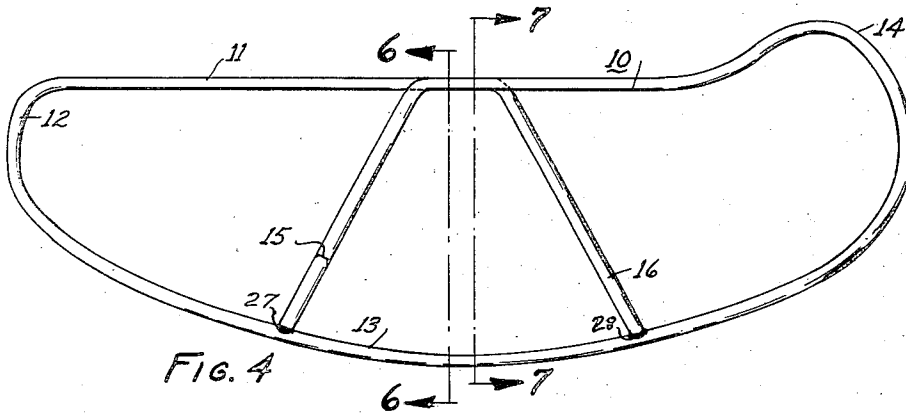

FIG. 4

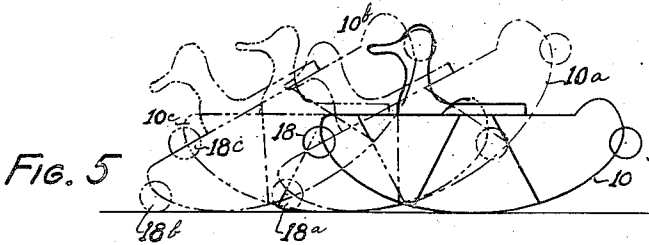

FIG. 5

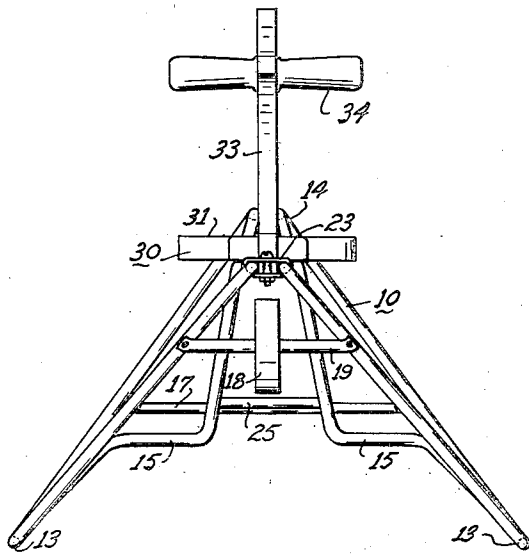

FIG. 3

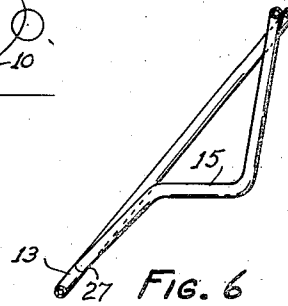

FIG. 6

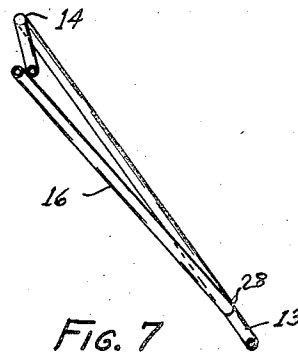

FIG. 7

INVENTOR:
HERBERT KUPPIN
BY *Morton S. Brockman*
ATTORNEY.

UNITED STATES PATENT OFFICE

2,462,648

HOBBYHORSE

Herbert Kuppin, Piqua, Ohio

Application February 6, 1946, Serial No. 645,892

4 Claims. (Cl. 272-53)

1

This invention relates to toys, and particularly to a rocking toy duck.

The primary object of this invention is to provide a rocking toy that a child can sit upon, and to which he can impart a real and effortless rocking motion by alternately shifting the center of gravity of the toy along a median line drawn from front to rear.

Another object is to provide a rocking toy with rollers so placed on the front and rear thereof that, if the motion is great enough in the process of rocking, the rollers will touch the floor and produce a rapid scooter-like forward or backward movement of the top, depending upon which roller is touching the floor.

A further object is to provide a rocking toy that can be used in the manner of a sled, since its structure is such that its rockers may serve as runners or gliders on snow or ice.

Still another object is to provide a rocking toy of simple but rugged construction that can be inexpensively manufactured out of bent metal bar stock or tubing.

These and other objects and advantages of the invention will become apparent from a reading of the following description and claims, together with the accompanying drawing, in which like parts are referred to and indicated by like reference characters and wherein:

Figure 1 is a side elevation of the rocking toy;

Figure 2 is a top plan view thereof;

Figure 3 is a front elevation thereof;

Figure 4 is a side elevation of one of the body members;

Figure 5 is a schematic representation of the operation of the device in achieving forward movement;

Figure 6 is a section through one of the body members, taken along the line and in the direction of the arrows 6-6 of the Figure 4; and

Figure 7 is a section through one of the body members, taken along the line and in the direction of the arrows 7-7 of the Figure 4.

The rocking toy constituting this invention is made essentially of two parts; a body portion, and a saddle portion, each of which will be described in detail hereinafter and in the order just stated.

The body portion is composed of two angularly opposed body members, broadly indicated by the reference numeral 10 in the Figure 1, which are preferably made of tubular steel, although any material possessing the required ductility and rigidity may be used.

The body member 10 is made of a single piece of tubular steel whose central section is bent to

2

form the curved bottom 13. One of the end sections is then bent to form the front end 12, the forward half of the top portion 11, which is parallel to the base of the body member, and the inclined brace or strut 16, which is formed by bending the tube downward at an angle of approximately thirty degrees to meet the curved bottom 13. This is most clearly shown in the Figure 7.

The other end section is bent to form the rear end 14, the rear half of the top portion 11, which is parallel to the base of the body member, and the stirrup portion 15, which is made by bending the tube downward, outward and again downward at an angle of approximately thirty degrees to meet the curved bottom 13. This is most clearly shown in the Figure 6. The two ends of the tube touching the curved bottom 13 are welded thereto, as indicated at points 27 and 28 of the drawings.

The two body members are secured together at two points along their top portions by means of the front clamp 23 and the rear clamp 24. These clamps are made of two opposing pieces of channeled metal shaped to receive the body member tubes and capable of being firmly drawn together by means of a nut and bolt. The body members are further immovably connected together by means of the front lateral brace 25 between the two stirrups 15, and the rear lateral brace 17 between the two inclined struts 16. The degree of angularity between the body members is determined by the length of these two braces.

The front wheel axle 19 and the rear wheel axle 22 act as additional braces between the two body members, and also serve to support the two front and rear wheels 18 and 21 respectively, which are freely rotatable thereon. The wheels are made of solid blocks of wood suitably shaped and fitted with holes to receive the axles.

The two wheels are mounted on the rocker as shown in the drawings; one at the front end of the rocker and one at the rear end. They are normally above the floor and not in contact with it. When the rocker is stationary each of the wheels may be a substantial distance above the floor to provide ample space for comfortable rocking. However, when the rocker is inclined to an angle slightly short of its over-bearing or capsizing position, in either front or rearward direction, one of the wheels will contact the floor as shown in the Figure 5.

The width of the tread or base presented to the floor by the assembled toy in relation to its height is such that it is physically impossible for any

3

child to lean far enough over the side of the toy to cause it to tip sideways.

Furthermore, longitudinal tipping is prevented by the wheels 18 and 21 which come into contact with the floor when the rocking velocity reaches a predetermined limit of safety, thus checking the rocking action and preventing the toy from being rocked over on its back. When this occurs the rocking motion is momentarily converted into a scooter-like horizontal motion which causes the toy to roll along the floor, on the particular wheel 18 or 21 that happens to be touching the floor, until the forces involved are dissipated to the extent that a normal rocking motion can again be resumed by the toy.

The saddle member, broadly indicated by the reference numeral 30 in the Figure 1, consists of a seat portion 31 made of wood or other suitable material which rests upon and can be moved horizontally along the track formed by the two top portions 11 of the opposed body members 10. The seat can be immovably positioned by means of the two seat clamps 32. The seat clamps 32 are carriage bolts which pass through holes in the seat and then through channeled pieces of metal which are shaped to receive the tubular top members. When the bolts are tightened, the seat is drawn tightly down upon and firmly fixed to the top portions 11. This adjustable feature enables children with various leg lengths to use the toy with safety and comfort, and also extends the useful life of the toy since it can be fitted to the child as he grows.

The head 33 is of plywood or other suitable material about three-fourth inch thick and securely attached to the front of the seat portion 31. The head is cut in the shape of and painted to simulate a duck's head, although it should be understood that any other appropriate design may be used. A handle bar 34 passes through a hole in the head 33 and is immovably affixed therein.

Having thus disclosed the invention in its preferred form, it should be understood that the invention as disclosed and illustrated is not to be construed in a limited sense as there may be other forms or modifications of the invention which also come within the scope of the appended claims.

I claim:

1. A rocking toy, comprising in combination,

4

two opposed rockable body members attached together, the said body members having front and rear wheels and a stirrup portion therebetween, each of the body members formed of a single length of metal bent to form a horizontal top portion, inclined front and rear end portions, a curved bottom portion and a lateral stirrup portion, and a saddle member mounted on the body member.

2. A rocking toy, comprising in combination, two opposed rockable body members attached together, the said body members having front and rear wheels and a stirrup portion therebetween, each of the body members formed of a single length of metal bent to form a horizontal top portion, inclined front and rear end portions, a curved bottom portion and a lateral stirrup portion, and a saddle member mounted on the body member, the said saddle member having a head portion including a handle bar and being adjustably movable on the body member.

3. In a rocking toy, a body member, comprising, a unitary bar-like element having end portions and a central portion therebetween, the central portion being bent to form a rocker, one of the end portions bent to form a stirrup and attached to the rocker, the other of the end portions bent to form a strut and attached to the rocker.

4. In a rocking toy, a body member, comprising in combination, a bar-like element bent to form a rocker having saddle and stirrup portions, the said rocker also having front and rear ends, and a wheel mounted on each of said ends, the said wheels being spaced from the floor when the rocker is in a normal or stationary position and separately in contact therewith and rollable thereon when the rocker is inclined at an angle slightly short of its capsizing position.

HERBERT KUPPIN.

REFERENCES CITED

The following references are of record in the file of this patent:

FOREIGN PATENTS

Number	Country	Date
432,307	Great Britain	July 24, 1935