



- (51) International Patent Classification:
B64C 27/08 (2006.01)
- (21) International Application Number:
PCT/IB2014/000415
- (22) International Filing Date:
25 March 2014 (25.03.2014)
- (25) Filing Language: English
- (26) Publication Language: English
- (71) Applicant: ALSHDAIFAT, Wasfi [AE/AE]; P.O. Box 46618, Abu Dhabi (AE).
- (72) Inventors; and
- (71) Applicants : ALMUHAIRBI, Eida [AE/AE]; P. O. Box 46618, Abu Dhabi (AE). KASSAB, Farah, Afif [LB/AE]; P.O. Box 46618, Abu Dhabi (AE).
- (74) Common Representative: ALSHDAIFAT, Wasfi; P.O. Box 46618, Abu Dhabi (AE).
- (81) Designated States (unless otherwise indicated, for every kind of national protection available): AE, AG, AL, AM,

AO, AT, AU, AZ, BA, BB, BG, BH, BN, BR, BW, BY, BZ, CA, CH, CL, CN, CO, CR, CU, CZ, DE, DK, DM, DO, DZ, EC, EE, EG, ES, FI, GB, GD, GE, GH, GM, GT, HN, HR, HU, ID, IL, IN, IR, IS, JP, KE, KG, KN, KP, KR, KZ, LA, LC, LK, LR, LS, LT, LU, LY, MA, MD, ME, MG, MK, MN, MW, MX, MY, MZ, NA, NG, NI, NO, NZ, OM, PA, PE, PG, PH, PL, PT, QA, RO, RS, RU, RW, SA, SC, SD, SE, SG, SK, SL, SM, ST, SV, SY, TH, TJ, TM, TN, TR, TT, TZ, UA, UG, US, UZ, VC, VN, ZA, ZM, ZW.

- (84) Designated States (unless otherwise indicated, for every kind of regional protection available): ARIPO (BW, GH, GM, KE, LR, LS, MW, MZ, NA, RW, SD, SL, SZ, TZ, UG, ZM, ZW), Eurasian (AM, AZ, BY, KG, KZ, RU, TJ, TM), European (AL, AT, BE, BG, CH, CY, CZ, DE, DK, EE, ES, FI, FR, GB, GR, HR, HU, IE, IS, IT, LT, LU, LV, MC, MK, MT, NL, NO, PL, PT, RO, RS, SE, SI, SK, SM, TR), OAPI (BF, BJ, CF, CG, CL, CM, GA, GN, GQ, GW, KM, ML, MR, NE, SN, TD, TG).

[Continued on next page]

(54) Title: DRONE SERVICE AERO-CARRIER

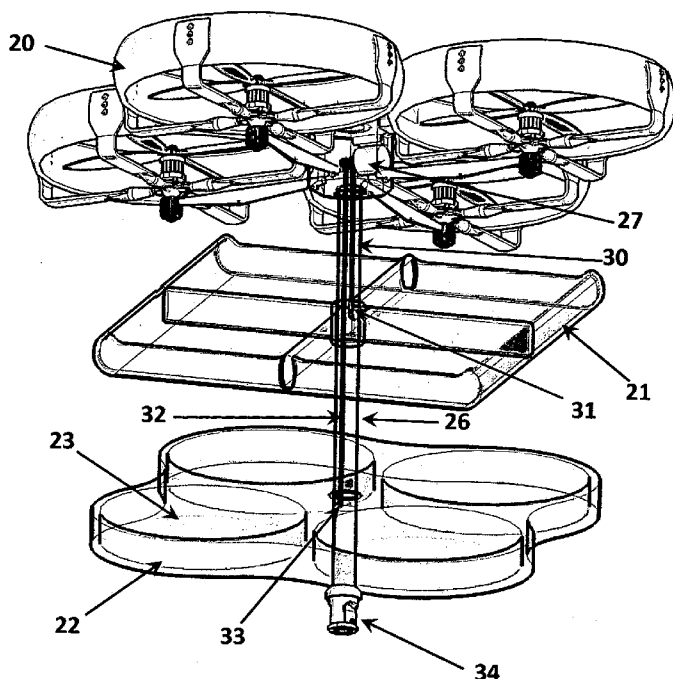

FIG. 3

(57) Abstract: To provide drones service aero-carrier (20), a big drone (20) is carrying and supporting two levels of trays (21), (22), each tray is divided into many compartments, where a loaded mini drone (24) or parcels (25) are to be located. The aero-carrier is connected to the trays (21), (22) from its bottom center via a telescopic shaft (26), which is welded to the top tray (21), and penetrating it toward the lower tray (22), where it is welded to it too. Trays space (gap) adjustment mechanism is provided too, depending on a motor, pulleys, and strings, to pull up the trays (21), (22) with the telescopic shaft (26) to hold the mini drones, or parcels while in flight, or to let the trays (21), (22) move down to expand the gap to the mini drones to be released out while unloading the aero-carrier (20).



Declarations under Rule 4.17:

— *as to applicant's entitlement to apply for and be granted a patent (Rule 4.17(ii))*

Published:

— *upon request of the applicant, before the expiration of the time limit referred to in Article 21(2)(a)*
— *without international search report and to be republished upon receipt of that report (Rule 48.2(g))*

DRONE SERVICE AERO-CARRIER

Description of the Invention

Technical Field of Invention

This invention relates to an unmanned aerial vehicle, specified for carrying
5 drones to a work area.

Background Art

Unmanned aerial vehicles, which are also called pilotless aircraft or remote
piloted vehicle, are finding their way to market recently, and in the near future,
in numerous commercial and civil uses. From thermal or video camera imaging,
10 to parcels delivery, farming, surveying of crops, acrobatic aerial footage in
filmmaking, search and rescue operations, construction industry, inspecting
powerlines, dams, pipelines, counting wildlife, delivering medical supplies to
remote or otherwise inaccessible regions, determining of illegal hunting by
animal-rights advocates, livestock monitoring, wildfire mapping, pipeline
15 security, home security, road patrol, and anti-piracy, search and rescue,
dropping life preservers to plural swimmers, damage assessment, all-weather
imaging through the clouds, rain, or fog, and in a daytime or night times
conditions, all in real-time.

Drones are also used for remote sensing tasks, their remote sensing functions
20 include multiple electromagnetic spectrum sensors, gamma ray sensors,
biological sensors, chemical sensors, optical sensors, infrared camera,
synthetic aperture radar.

To be capable to carry out such rasks, the drones themselves should perform
some inner operations and functions, like Sensing, data manipulation, and
25 communication. To avoid accidents, or missing the target, they should have the
followings capabilities:

Path planning: determining an optimal path for vehicle to follow while meeting
certain objectives and mission constraints, such as obstacles or fuel
requirements.

30 **Trajectory generation (sometimes called motion planning):** determining an
optimal control maneuver to take in order to follow a given path or to go from
one location to another.

Trajectory regulation: The specific control strategies required to constrain a vehicle within some tolerance to a trajectory.

Task allocation and scheduling: Determining the optimal distribution of tasks amongs a group of agents within time and equipment constraints.

5 **Cooperative tactics:** Formulating an optimal sequence and spacial distribution of activities between agents to maximize the chance of success in any given mission scenario.

All of these factors related to the vast and variable tasks of the drones, with the capabilities they should earn to control their paths, trajectories, targets.. means
10 thousands of drones will be operating at the same time in a medium-sized country, which means these capabilities will face too much complications related to the high traffic of the drones, as it is unlike automobiles which are following specific roads, and unlike aircrafts which have the atomosphere wide enough to provide easy control of their traffic, drones should move and work
15 inbetween the buildings, trees, over the roads, as a result many of them at the same time will be crossing near each other and near other physical things.

It is of no doubt such busy traffic will create an increasingly dangerous accidents. Immense efforts to develop their autonomous operations will be highly expensive, complicated and may be of little benefit.

20 These drawbacks, in addition to the annoyance, and distort of the city appearance, can be solved only if it is thought of the matter like in normal vehicles traffic solutions, wherein a bus carries 50 passengers, and a truck carries 10-15 vehicles from the ports to storages, similarly, a drones service
25 aero-carrier can offer a straight solution to carry 5 – 15 mini drones from one location to another location, or to carry parcels to be delivered to a mini drone (taxi) waiting or receiving the parcels in a limited area, instead of travelling long distances, so it is like a bus transporting passengers from long distances to a drones (taxi) station, or a truck delivering shipments and parcels to pick ups station.

30 The prior art is not showing any invention of such a relevance, this invention discloses how to build such a drone aero-carrier machine, which can decrease the mini drones crowded traffic by nearly 80-90 % in the future.

Disclosure of Invention

Brief Description

To provide drones service aero-carrier, a big drone is carrying and supporting two levels of trays, each tray is divided into many compartments, with a circular or square shape, where loaded mini drone or parcels are to be located.

The aero-carrier drone is to have an area that is bigger than any of the trays while loaded, its size is bigger, and its power is enough to support carrying two loaded levels of trays. The aero-carrier drone is connected to the trays from its bottom center via a telescopic shaft, which is welded to the top tray, and penetrating it toward the bottom tray, where it is welded too.

Trays space (gap) adjustment mechanism is provided too, at the top of the telescopic shaft a motor is located with two pulleys installed at the end of its drive shaft, on the first pulley a string is rotated around it, and extending to a center point inside the shaft, located at the same level of the top tray, where it is connected to a metallic extension from the top luggage tray. Also from the second pulley, in the same way a second string is extending to be fixed to a second metallic extension from the bottom tray.

When the mini drones are to be released from the trays, the motor is rotated to unwind the strings, such that the load of each tray pushes on the telescopic shaft to move down, then the shaft starts to expand, increasing the space in-between the top tray and the aero-carrier, and increasing too the space in-between the bottom and top trays.

When the aero-carrier is loaded with the mini drones, for preventing the mini drones from falling, and for providing a compact shape, the motor is rotated to wind the strings, such that each tray is pushed up via the metallic extension, as the trays are welded to the telescopic shaft, they will push on it to move up, then it starts to shorten, decreasing the space in-between the top tray and the aero-carrier, and decreasing too the space in-between the bottom and top trays.

Brief Description of the Drawings:

- FIG. 1: Illustrates a 3-D view for the drone service aero-carrier while unloaded.
- FIG. 2: illustrates a 3-D view for the trays gaps adjustment mechanism.
- 5 ● FIG. 3: illustrates a transparent 3-D view for the strings penetrating the telescopic shaft at the top and bottom trays center side.
- FIG. 4: illustrates a 3-D view for the drone service aero-carrier while the trays are pulled up.
- FIG. 5: Illustrates a 3-D view for the drone service aero-carrier loaded with mini drones.
- 10 ● FIG. 6: illustrates 2-D view for the drone aero-carrier while loaded with trays expanded to release mini drones.
- FIG. 7: Illustrates a 3-D view for the drone service aero-carrier while some loaded mini drones are departing.
- 15 ● FIG. 8 (A, B): Illustrates a 3-D view for a mini drone while unloaded, and loaded.
- FIG. 9: Illustrates a 3-D view for a mini drone while arriving - unloading - departing an aero-carrier loaded with parcels.

20 Detailed description for carrying out the Invention:

Best Mode for Carrying out the Invention:

In order to make it easy to carry out the invention, a detailed description of the parts of the invention, supported with figures, is provided here, wherein the main parts are arranged sequentially, according to the importance of the part, we made it easy to read, by referring to each feature, with a number included in
25 the parts description text, and in the parts numbering list, the numbering of parts features is indicated here, by starting it sequentially from number 20,

whenever a part feature appears in a text, it will be directly assigned its required serial number. As example in FIG. 1, the parts' features are arranged sequentially from number 20, 21, 22...

5 The aero-space used by drones is to be called aero-traffic space, its height is to be nearly 3,000 meters, this space is to be divided into two, top part: for big aero-carrier drones, and lower part: for taxi drones (mini drones) direct delivery.

The aero-carrier drones are to carry either mini drones, with their parcels already loaded, the loading of the aero-carrier drone can be carried either at a
10 ground hub, or while it is in flight, or hovering in the air, over a local multiple nearby points of delivery. The aero-carrier drone can deliver either a loaded mini drones from the aero-space, or to land to deliver the parcels directly to another ground hub.

The drone service aero-carrier 20 is built up like in the following:

- 15 1- A drone aero-carrier 20 construction (FIG. 1): a big drone 20 is carrying and supporting two levels of trays 21, 22, each tray is divided into many compartments 23, with a circular or square shape, where a loaded mini drone 24 or parcels 25 are to be located. The aero-carrier drone 20 is to have an area that is bigger than any of the trays 21, 22 while loaded, its size is
20 bigger, and its power is enough to support carrying two levels of trays 21, 22. The aero-carrier drone is connected to the trays 21, 22 from its bottom center via a telescopic shaft 26, which is welded to the top tray 21, and penetrating it toward the bottom tray 22, where it is welded to it too.
- 25 2- A Mechanism for controlling trays separation gaps (FIG. 2, 3, 4): while loading the trays 21, 22, there should be enough space or gap in-between the bottom 22 and top tray 21, and in-between the top tray 21 and the aero-carrier drone 20, but while the aero-carrier drone 20 is in flight, the gaps should be decreased to min. so that the parcels 25 or the loaded mini drones 24 do not fell down, as a requirement, a mechanism is provided for
30 loading and unloading gap adjustment, for protecting the loaded items from falling down while in flight.

The trays 21, 22 space (gap) adjustment mechanism is provided such that, at the top of the telescopic shaft 26 a motor 27 is located with two pulleys 28, 29 installed at the end of its drive shaft. On the first pulley 28, a first string 30 is rotated around it, and extending to a center point inside the shaft 26, located at the same level of the top tray 21, where it is connected to a metallic extension 31 from the top tray 21. Also from the second pulley 29, in the same way a second string 32, is extending to be fixed to a second metallic extension 33 from the bottom tray 22.

When the mini drones 24 are to be released from the trays 21, 22, the motor 27 is rotated to unwind the strings 30, 32, such that the load of each tray 21, 22 pushes on the telescopic shaft 26 to move down, then the shaft 26 starts to expand, increasing the space in-between the top tray 21 and the drone aero-carrier 20, and increasing too the space in-between the bottom and top trays.

When the aero-carrier 20 is loaded with the mini drones 24, for preventing the mini drones 24 from falling, and for providing a compact shape, the motor 27 is rotated to wind the strings 30, 32, such that the each tray 21, 22 is pushed up via the metallic extension 31, 33, as the trays 21, 22 are welded to the telescopic shaft 26, they will push on it to move up, then it starts to shorten, decreasing the space in-between the top tray 21 and the aero-carrier drone 20, and decreasing too the space in-between the bottom and top trays.

Fig. 4 is showing the drone aero-carrier 20 with the trays 21, 22 compacted (trays pushed up to decrease the space in-between them)

3- Drone service aero-carrier 20 with mini drones 24 loaded (FIG. 5, 6, 7, 8): in one embodiment of multiple options of the aero-carrier 20, is to carry many mini drones 24 loaded with parcels 25, or what else, such that while it is in flight or hovering, it distributes these mini drones 24, to multiple points in a nearby locations, Fig. s (5, 6) are illustrating views for the mini drones 24 positioning, while loaded on the trays 21, 22 of the aero-carrier 20, while trays 21, 22 are at expanded position. Fig. 7 is illustrating mini drones 24 loaded with parcels 25, and departing the bottom tray 22, of the big aero-

carrier drone 20. Fig. 8- A, B is illustrating a mini drone 24 while unloaded, and while loaded with a parcel 25.

4- Drone service aero-carrier 20 loaded with parcels 25, with external mini drone 24 unloading it (FIG. 9): in another embodiment the aero-carrier 20 is carrying only parcels, to be delivered for one location with multiple nearby points of delivery, where the aero-carrier 20 either can land to unload the parcels 25 to a local delivery hub, or while it is hovering or in flight at a low height, mini drone 24 or more, approaches it for direct unloading, to carry the parcels 25 and distribute them to specific points of delivery. This embodiment save the load of mini drones 24 that are carried with their parcels 25 in the aero-carrier 20.

Note 1: the trays 21, 22 can be perforated from down side for preventing the accumulation of rain water, dust...etc.

Note 2: It is obvious for the inventors that many mechanisms can be applied for expanding the gap in-between the trays 21, 22.

Note 3: For more safety, the trays 21, 22 can be supported with different conventional ways, either from the bottom or the sides.

Note 4: The aero- carrier is having conventionally at the bottom of it a camera 34.

Industrial applicability:

- 1- Drone service aero-carrier with its trays and adjustment mechanism installations, made from available tools, parts, mechanisms, with applicable modifications.
- 5 2- Multiple uses in civil service unmanned transportation of necessary and urgent small parcels, it can be used by commercial sector, governmental departments, hospitals, traffic control..etc.
- 3- Carrying either a set of loaded drones, or carrying loads to be delivered to a waiting taxi mini drone, in a specific local place.
- 10 4- Drone service aero-carrier reshaping and reconstructing the lower aerospace traffic, to be less crowded, more organized, efficient, and beneficial.

15

20

25

Parts Drawing Index:

	20	Drone service aero-carrier.
	21	Top tray.
5	22	Bottom tray.
	23	Compartment.
	24	Mini drone.
	25	Parcel.
	26	Telescopic shaft.
10	27	Motor.
	28	First pulley.
	29	Second pulley.
	30	First string.
	31	First metallic extension.
15	32	Second string.
	33	Second metallic extension.
	34	Camera.

Claims

- 1- A drone service aero-carrier (20), for carrying loaded mini drones (24), or parcels (25), comprising:
 - a big drone (20);
 - a top tray (21);
 - a bottom tray (22);
 - a telescopic shaft (26);
 - a motor (27);
 - a first pulley (28);
 - a second pulley (29);
 - a first string (30);
 - a first metallic extension (31);
 - a second string (32);
 - a second metallic extension (33).
- 2- The drone service aero-carrier (20) according to claim 1, wherein a big drone (20) is carrying and supporting two levels of trays (21), (22) with each tray divided into many compartments (23), supporting loaded mini drones (24) or parcels (25).
- 3- The drone service aero-carrier (20) according to claim 1, wherein the big drone (20) is connected to the trays (21), (22) from its bottom center via a telescopic shaft (26), which is welded externally to the top tray (21), and penetrating it toward the bottom tray (22), where it is welded to it too.
- 4- The drone service aero-carrier (20) according to claim 1, wherein the motor (27) is rotating a two pulleys (28), (29), to rotate two strings (30) (32) which are connected to the top and bottom trays (21), (22) via first and second metallic extensions (31), (33) successively. When the mini drones (24) are to be released from the trays (21), (22) the motor (27) is rotated to unwind the strings (30), (32) such that the load of each tray (21), (22) pushes on the telescopic shaft (26) to move down, increasing the space in-between the top tray (21) and the drone aero-carrier (20), and increasing too the space in-between the bottom and top trays. While if the motor (27) is rotated to wind the strings (30), (32) the trays (21), (22) are

- pushed up via the metallic extension (31), (33) to shorten the telescopic shaft (26) and as a result, shorten the gap in-between them.
- 5- The drone service aero-carrier (20) according to claim 1, wherein the trays (21), (22) can carry many mini drones (24) loaded with parcels (25), or the trays are loaded with parcels, which are unloaded by local mini drones (taxi drones) (24) approaching the aero-carrier (20) to unload it.

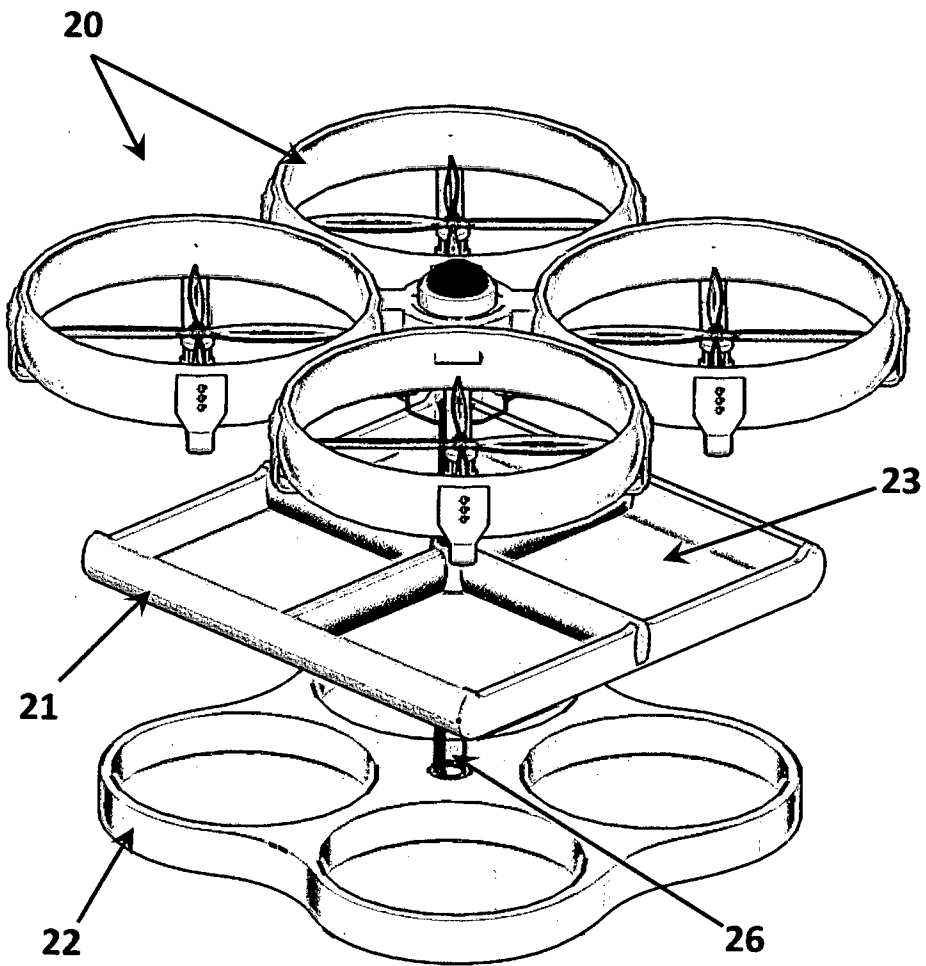

FIG. 1

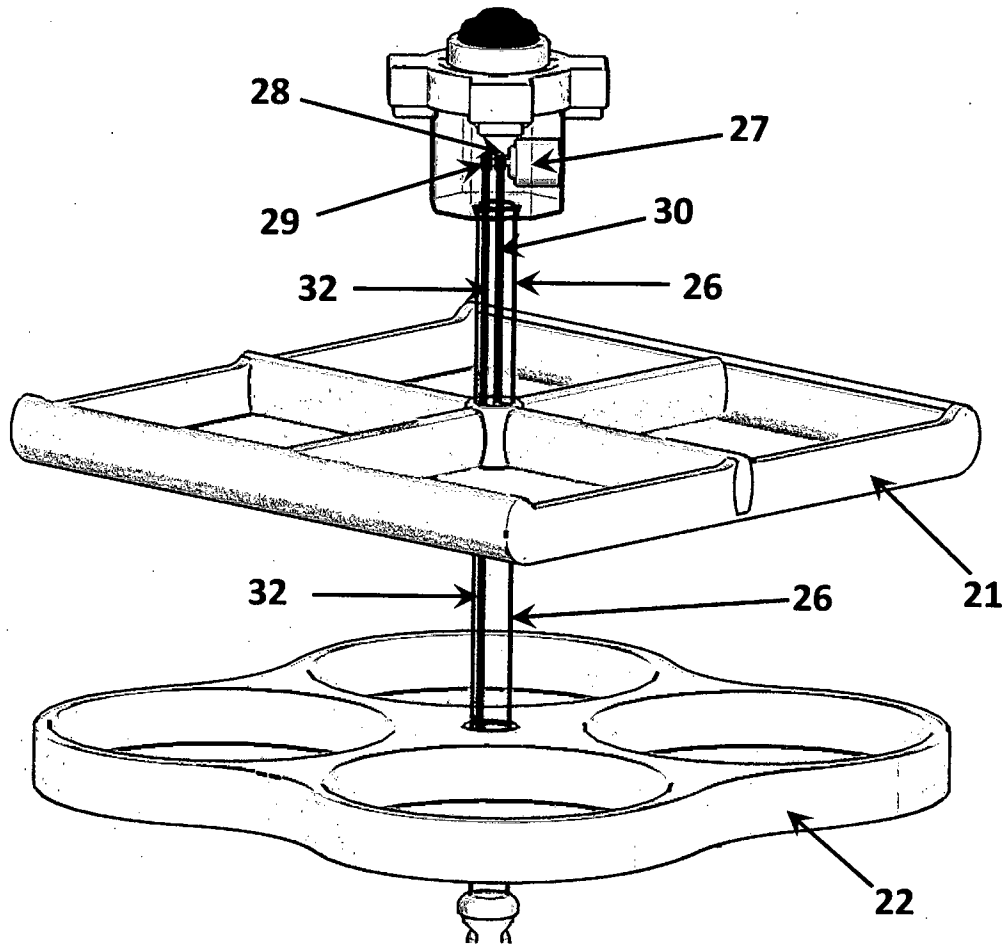

FIG. 2

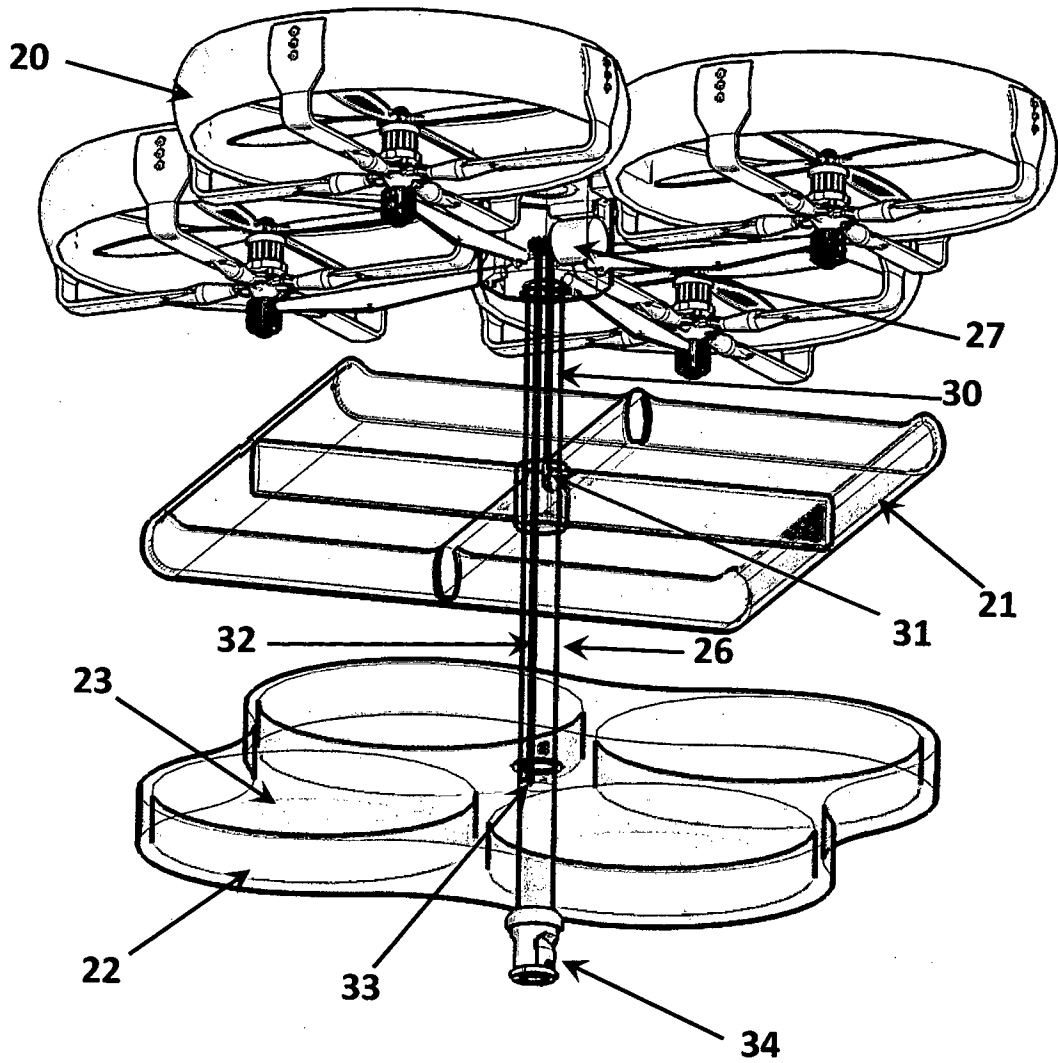

FIG. 3

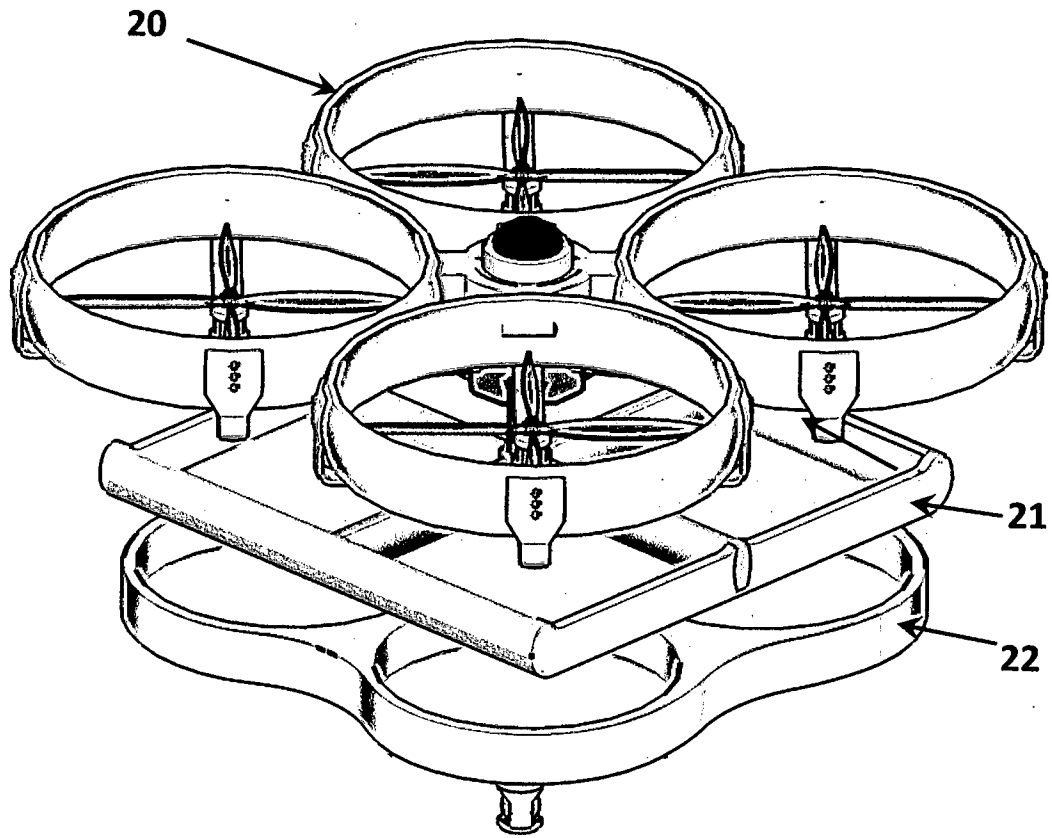

FIG. 4

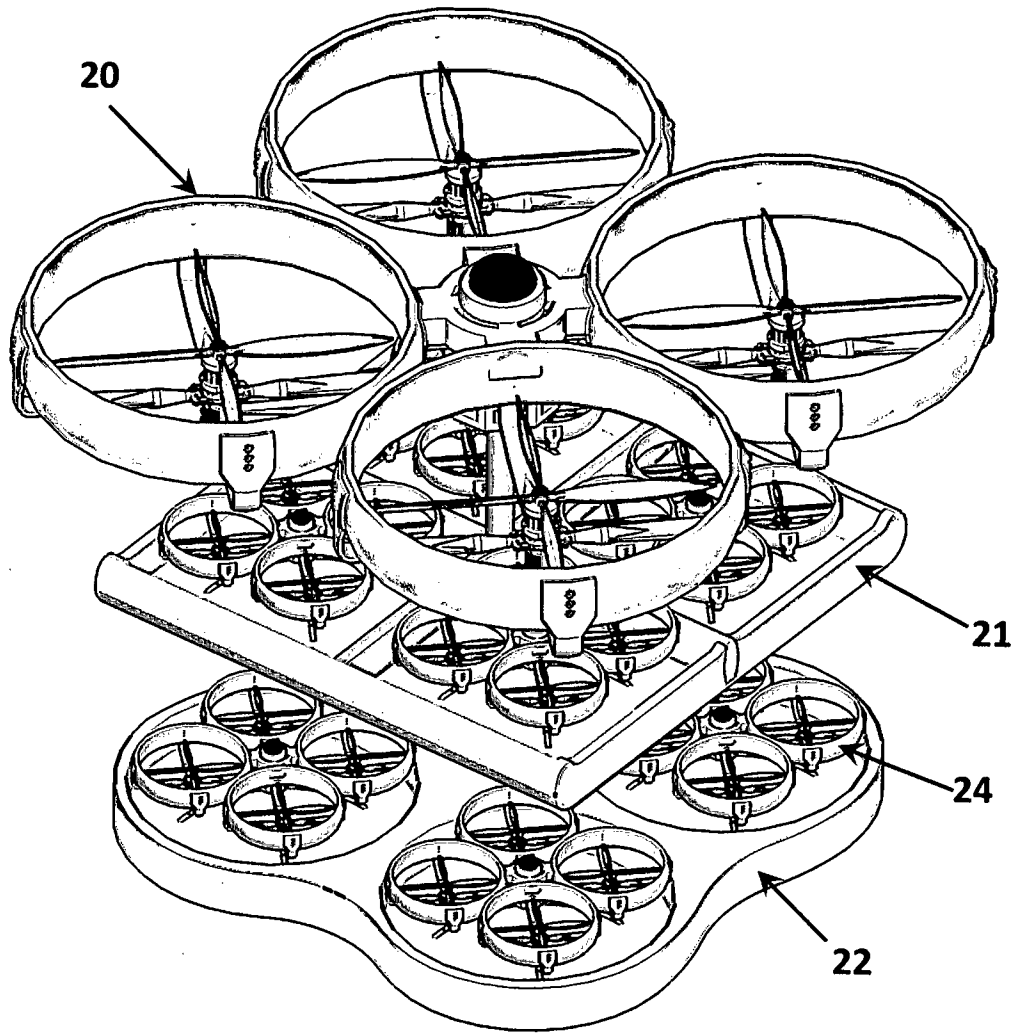

FIG. 5

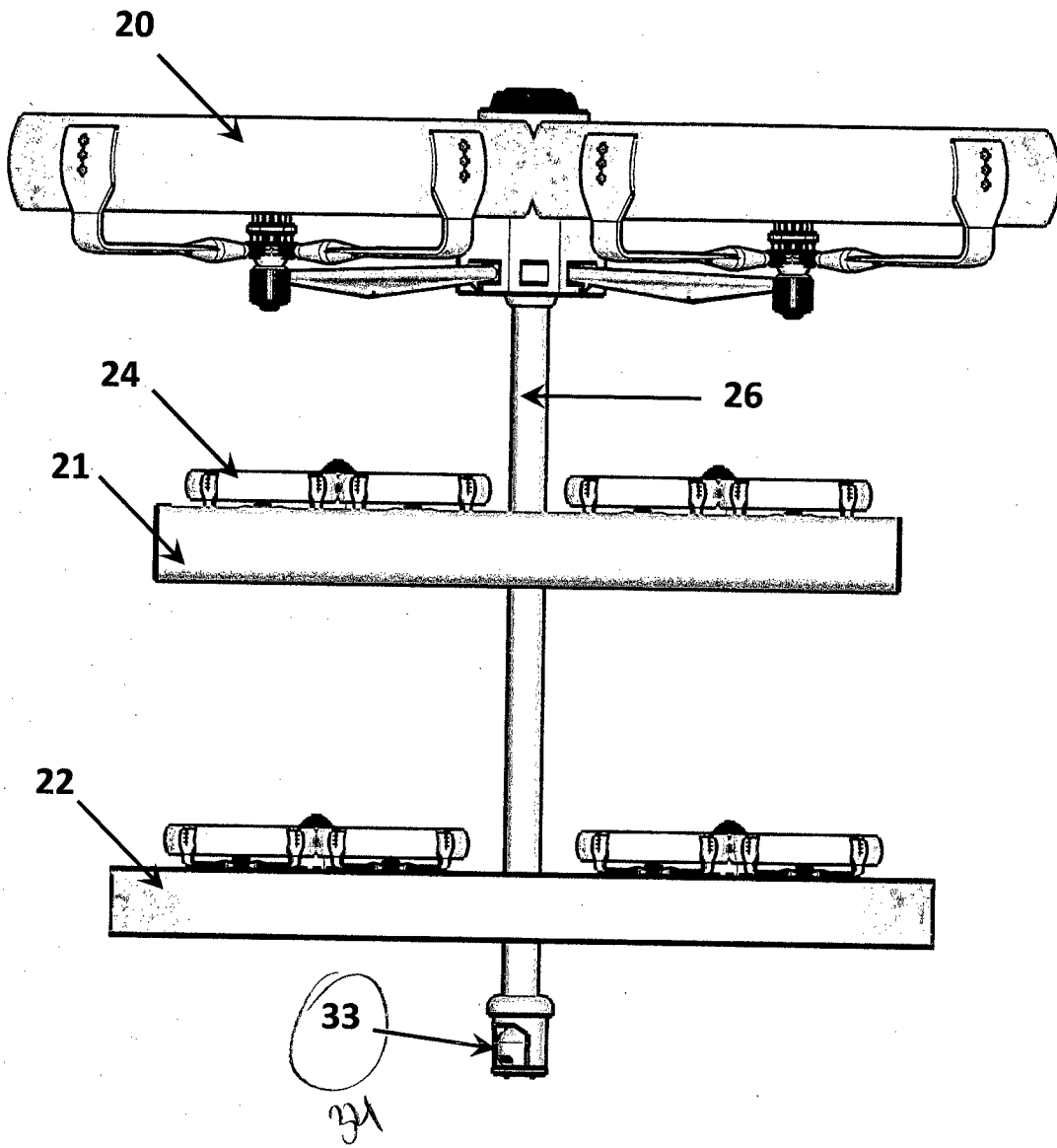

FIG. 6

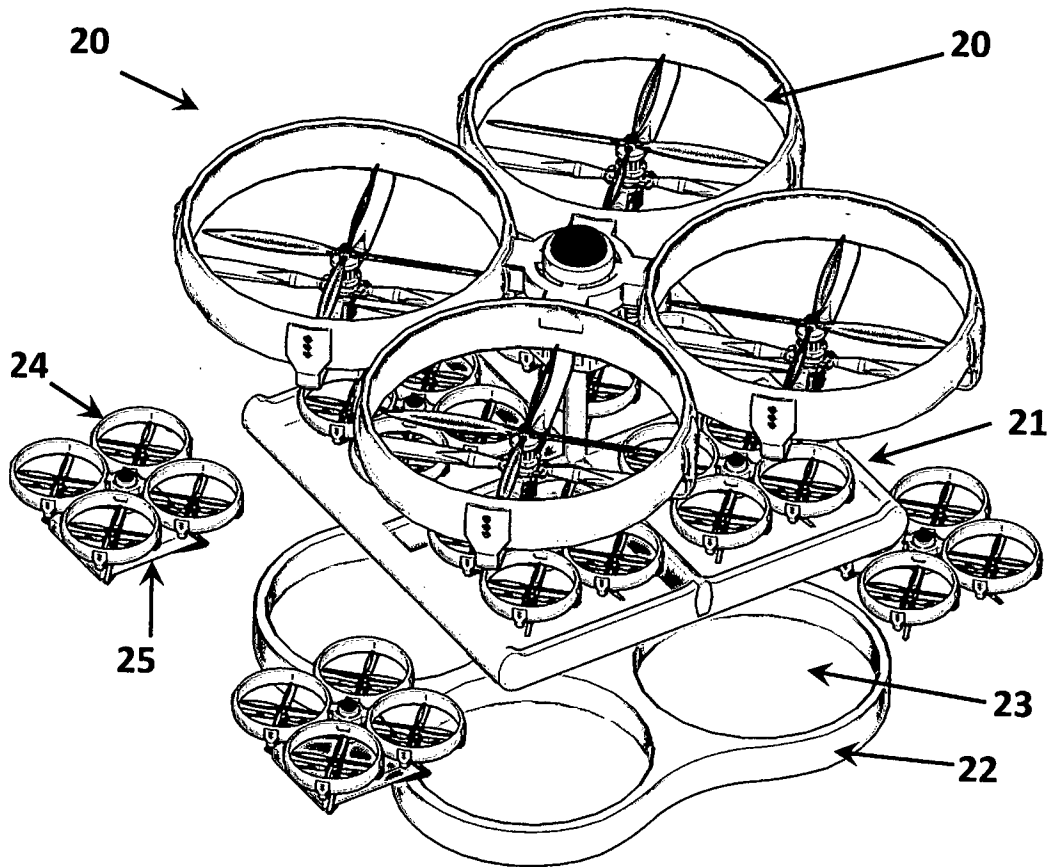

FIG. 7

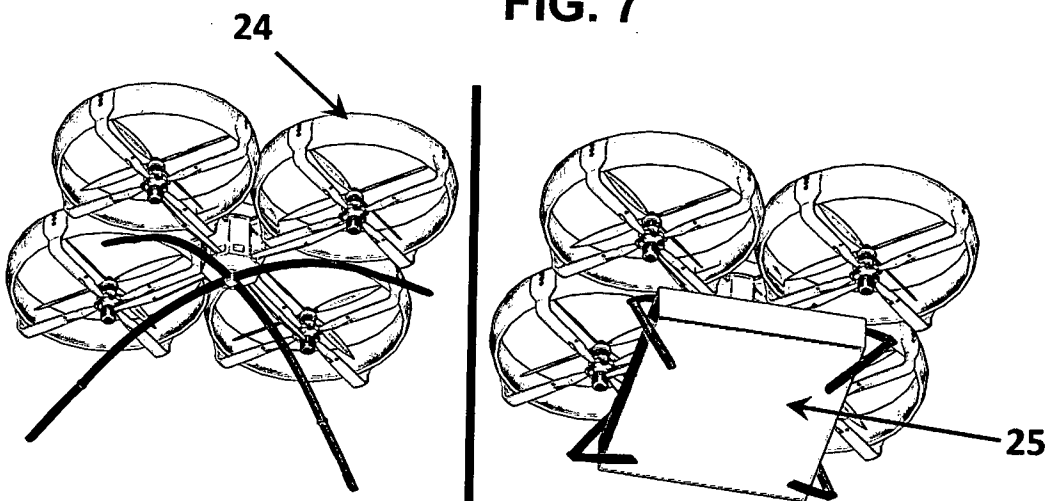

FIG. 8 (A, B)

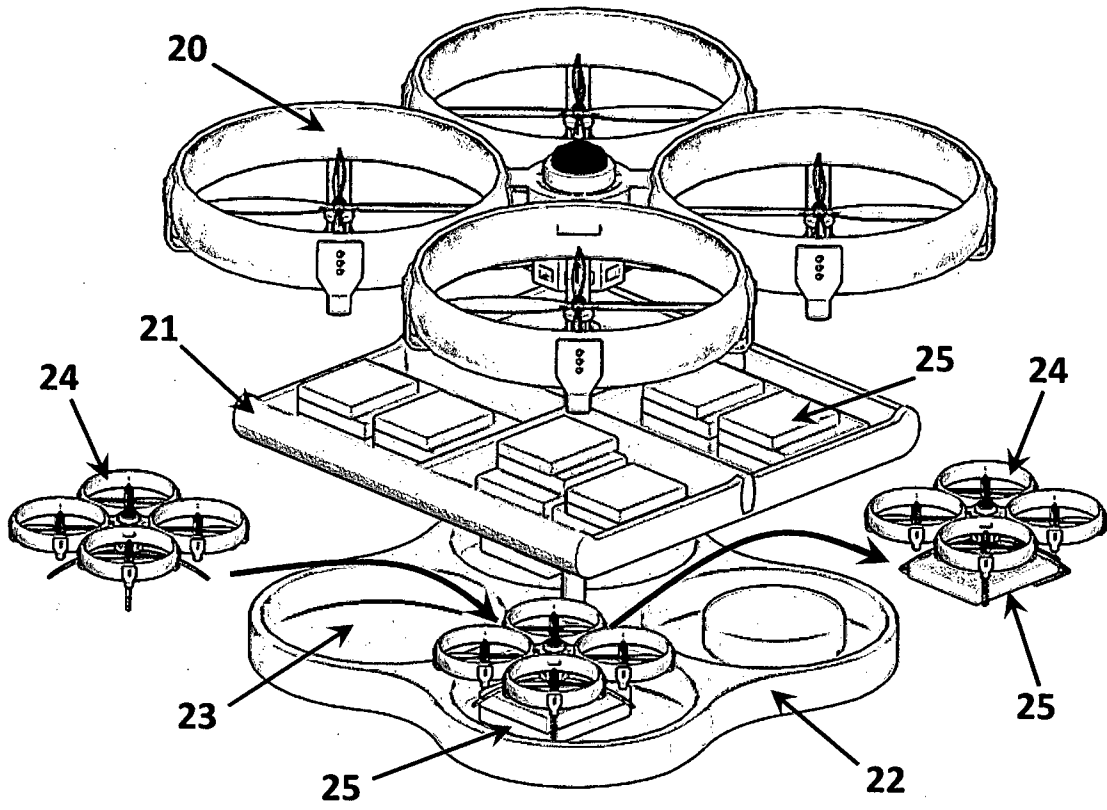

FIG. 9