

Feb. 7, 1928.

1,658,580

T. W. THAXTON

GAS SAVER

Filed Jan. 10, 1927

Fig. 1.

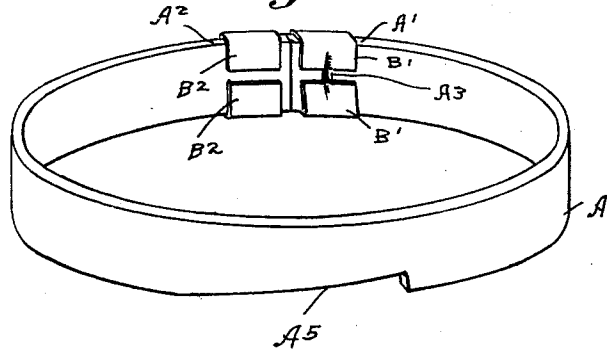

Fig. 3.

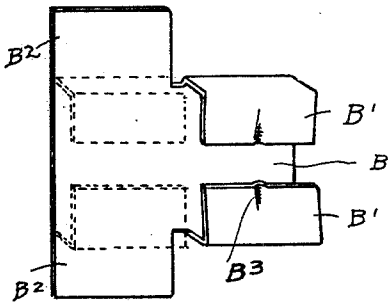

Fig. 2.

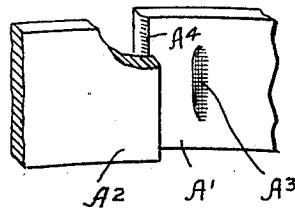
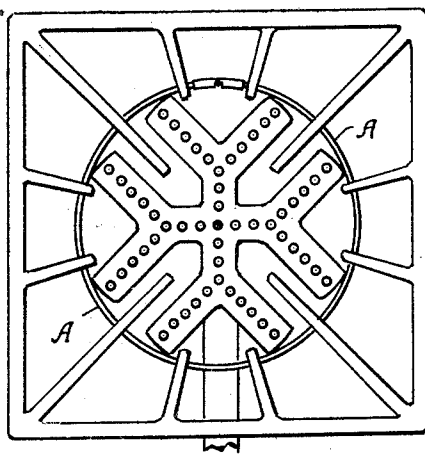
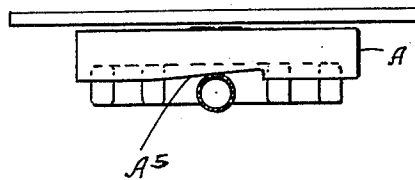

Fig. 4.



↑ 5

Fig. 5.



INVENTOR
Thomas W. Thaxton
By *Thomas L. Ryan*
ATTORNEY.

UNITED STATES PATENT OFFICE.

THOMAS W. THAXTON, OF MUNCIE, INDIANA, ASSIGNOR OF ONE-HALF TO SENATE G. HUNT, OF MUNCIE, INDIANA.

GAS SAVER.

Application filed January 10, 1927. Serial No. 160,108.

This invention relates to improvements in gas-burner attachments of that type used in connection with burners of cooking stoves of the platform or "hot-plate" class wherein the burner is positioned on a plane below the grating upon which the cooking utensil is disposed, and the vents in the burner are located so that the flames are directed upwardly.

Although devices have heretofore been developed to conserve the heat produced by such a burner by shielding the flames from air currents and preventing them from being deflected from their directly upward flow, I am not aware that any prior inventions have been wholly effective or practicable.

The object of my invention is to provide an attachment for gas burners of the kind referred to, which is capable of adaptation to burners of different makes and diameters, and which is easy to install, dependable, efficient and durable, and which is economical of manufacture.

The advantages sought by my invention are accomplished by, and the invention is embodied in the new construction, combination and arrangement of parts illustrated in the accompanying drawings, and described in the following specification. The invention is defined in the appended claim.

The several parts of my invention are identified by suitable reference characters, applied to them in the drawings, in which—

Figure 1 is a perspective view of my improved gas burner attachment.

Figure 2 is a perspective view showing the relative positions of the ends of the band before the jointure clip has been placed in position.

Figure 3 is a detail perspective view of the jointure clip showing the position of its grip fingers before placed at its position in connection with the ends of the band.

Figure 4 is a plan view of my improved attachment in position for use on a burner of common form.

Figure 5 is a side view taken in direction of the arrow 5 in Figure 4.

My invention contemplates the providing of a metal bar of suitable length curled into the formation of an annular band, and a metal jointure clip adapted to hold the meeting ends of the bar in alignment, one end of the bar being secured to, and the other end of the bar being movable in, the said

jointure clip; the device thus constructed being capable of expansion to encircle the burner and by its constrictory action, to then automatically retain tight connection with said burner, regardless of contraction and expansion of the burner, and also of the band itself, due to temperature changes.

To provide for alignment of the band on a burner in which the top surface of the inlet pipe is on a plane abnormally above the plane of the bottom of the burner, an inclined recess is provided in the lower portion of the band.

My invention in the present specification is embodied in an attachment of dimension and form suitable for burners of average size, the band consisting of a steel or iron bar A about one and one quarter inches wide, three sixteenths of an inch thick and of length to constitute a band about four and one half inches in diameter. This bar is of predetermined length, sheared from stock material and at the time of shearing is indented near one of its ends, namely its end A¹, with a shallow transverse groove A², and the edge A⁴ is slightly tapered. A relatively long recess in the lower edge of the body portion of the bar has an inclined face A⁵ and is preferably formed by shearing. This operation may be performed by dies arranged in the power press to act concurrently with the die that shears the end of the bar and that also forms the indentation A². The bar is then curled or rolled into annular form, its curvature being such that one of its ends passes or overlaps the other a slight distance, as shown in Figure 2.

The jointure clip is made of sheet steel and is of the formation as shown in Figure 3. Complementary grip fingers B¹ and B² spaced apart, a distance equal to the width of the end portion A¹ of the bar are each bent at a right angle to the body portion B of the clip, thence at an angle inclined toward the said body. Each of these grip fingers is provided with an indentation at its edge which provides the ridge B³. When this jointure clip is started on to the tapered edge A⁴ of the end A¹ of the band, and is then slipped longitudinally, the inner faces of the fingers B¹ bind tightly against the surface of the band and the ridges B³ snap into the grooves A² of said band. Thus the jointure clip is tightly secured to the end A¹ of the band. The band is then slightly ex-

panded, the end A² snapping into registration with the end A¹. The complementary retainers B² and B¹ are then bent at a right angle to the body portion of the clip, thence parallel thereto, (see dotted lines in Figure 3) and in position engaging the edges and inner face of the end A² of the band (as shown in Figure 1).

It is obvious that a band device constructed in accordance with my invention is not only of rugged strength and bulk to withstand the wear and tear incidental to its continual use, but it is capable of being easily expanded or distended by the user, so that it may be placed at position encircling the burner. When so placed in position its tendency to return or constrict to its normal diameter causes it to grip the edges of the burner effectively, thereby maintaining its position. One end of the bar being free in its connection with the jointure clip, there is a sufficient yield to compensate for such change in diameter of the burner as may occur due to rising and lowering temperatures.

To accommodate a burner of the make in which the inlet pipe is at a height abnormally above the plane of the bottom of the burner, there is provided the inclined recess. Thus, the user may set, or position the band

to rest directly on said inlet pipe at such height as may be desired.

I am aware that minor changes may be made in the detail and general construction of my invention within the scope of same as defined by the appended claim, without departing from the spirit of my invention or sacrificing any of its advantages.

What I claim as my invention, and desire to secure by Letters Patent, is—

A gas burner attachment consisting of a resilient divided band, one of the ends of the band having its inner edge of beveled formation, and its inner face being provided with a groove, a sheet metal jointure plate having two pairs of opposed complementary fingers, the fingers of one pair being bent toward each other and to proximate positions near the body portion of the plate and having ridges therein so that when the beveled end of the band is passed underneath these fingers, their ridges become imbedded in said groove, and the other pair of fingers being bent toward each other and to engagement with the inner face of the other end of the band after the latter has been disposed in engagement with the body portion of the jointure plate.

THOMAS W. THAXTON.