

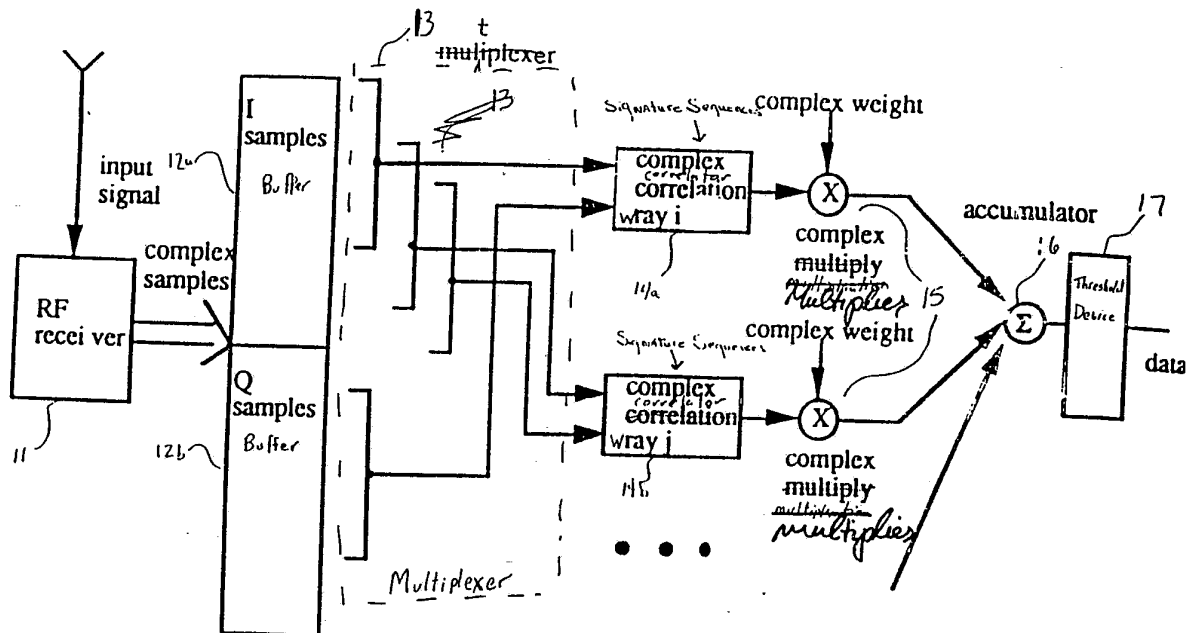

INTERNATIONAL APPLICATION PUBLISHED UNDER THE PATENT COOPERATION TREATY (PCT)

<p>(51) International Patent Classification 5 : H04L 27/30</p>	<p>A1</p>	<p>(11) International Publication Number: WO 93/19552 (43) International Publication Date: 30 September 1993 (30.09.93)</p>
<p>(21) International Application Number: PCT/US93/02840 (22) International Filing Date: 25 March 1993 (25.03.93) (30) Priority data: 857,433 25 March 1992 (25.03.92) US (71) Applicant: ERICSSON GE MOBILE COMMUNICATIONS INC. [US/US]; One Triangle Drive, Research Triangle Park, NC 27709 (US). (72) Inventor: BOTTOMLEY, Gregory, E. ; 100 Merlot Court, Cary, NC 27511 (US). (74) Agents: GRUDZIECKI, Ronald, L. et al.; Burns, Doane, Swecker & Mathis, George Mason Building, Washington and Prince Streets, P.O. Box 1404, Alexandria, VA 22313-1404 (US).</p>		<p>(81) Designated States: AU, BR, CA, FI, JP, KR, NZ. Published <i>With international search report.</i> <i>With amended claims.</i></p>

(54) Title: RAKE RECEIVER WITH SELECTIVE RAY COMBINING



(57) Abstract

Chips samples arrive via an RF receiver (11) and I and Q buffers (12a, 12b), where they are passed to a multiplexer (13). The multiplexer (13) selects two independent ranges of chip samples from the same or different channels. The outputs of the multiplexer (13) are correlated to a known sequence in complex correlators (14a, 14b), whose outputs are, in turn, multiplied by complex weights in complex multipliers (15). The products are then passed to an accumulator (16), whose output is sent to a threshold decision device (17) to yield the binary data extracted from the received signal.

FOR THE PURPOSES OF INFORMATION ONLY

Codes used to identify States party to the PCT on the front pages of pamphlets publishing international applications under the PCT.

AT	Austria	FR	France	MR	Mauritania
AU	Australia	GA	Gabon	MW	Malawi
BB	Barbados	GB	United Kingdom	NL	Netherlands
BE	Belgium	GN	Guinea	NO	Norway
BF	Burkina Faso	GR	Greece	NZ	New Zealand
BG	Bulgaria	HU	Hungary	PL	Poland
BJ	Benin	IE	Ireland	PT	Portugal
BR	Brazil	IT	Italy	RO	Romania
CA	Canada	JP	Japan	RU	Russian Federation
CF	Central African Republic	KP	Democratic People's Republic of Korea	SD	Sudan
CG	Congo	KR	Republic of Korea	SE	Sweden
CH	Switzerland	KZ	Kazakhstan	SK	Slovak Republic
CI	Côte d'Ivoire	LJ	Liechtenstein	SN	Senegal
CM	Cameroon	LK	Sri Lanka	SU	Soviet Union
CS	Czechoslovakia	LU	Luxembourg	TD	Chad
CZ	Czech Republic	MC	Monaco	TG	Togo
DE	Germany	MG	Madagascar	UA	Ukraine
DK	Denmark	ML	Mali	US	United States of America
ES	Spain	MN	Mongolia	VN	Viet Nam
FI	Finland				

RAKE RECEIVER WITH SELECTIVE RAY COMBININGFIELD OF INVENTION

The present invention relates to the use of Code
Division Multiple Access (CDMA) communications
5 techniques in cellular radio telephone communication
systems, and more particularly, to a RAKE receiver
scheme for correlating a despreading code sequence
with the received signal samples to determine the
received data sequences.

10 BACKGROUND OF THE INVENTION

CDMA or spread spectrum communications have been
in existence since the days of World War II. Early
applications were predominantly military oriented.
However, today there has been an increasing interest
15 in using spread spectrum systems in commercial
applications. Some examples include digital cellular
radio, land mobile radio, and indoor and outdoor
personal communication networks.

The cellular telephone industry has made
20 phenomenal strides in commercial operations in the
United States as well as the rest of the world.
Growth in major metropolitan areas has far exceeded
expectations and is outstripping system capacity. If
this trend continues, the effects of rapid growth
25 will soon reach even the smallest markets.
Innovative solutions are required to meet these
increasing capacity needs as well as maintain high
quality service and avoid rising prices.

Throughout the world, one important step in
30 cellular systems is to change from analog to digital
transmission. Equally important is the choice of an
effective digital transmission scheme for
implementing the next generation of cellular

- 2 -

technology. Furthermore, it is widely believed that the first generation of Personal Communication Networks (PCNs), employing low cost, pocket-size, cordless telephones that can be carried comfortably and used to make or receive calls in the home, office, street, car, etc., will be provided by cellular carriers using the next generation digital cellular system infrastructure and the cellular frequencies. The key feature demanded in these new systems is increased traffic capacity.

Currently, channel access is achieved using Frequency Division Multiple Access (FDMA) and Time Division Multiple Access (TDMA) methods. In FDMA, a communication channel is a single radio frequency band into which a signal's transmission power is concentrated. Interference with adjacent channels is limited by the use of band pass filters which only pass signal energy within the specified frequency band. Thus, with each channel being assigned a different frequency, system capacity is limited by the available frequencies as well as by limitations imposed by channel reuse. In TDMA systems, a channel consists of a time slot in a periodic train of time intervals over the same frequency. Each period of time slots is called a frame. A given signal's energy is confined to one of these time slots. Adjacent channel interference is limited by the use of a time gate or other synchronization element that only passes signal energy received at the proper time. Thus, the problem of interference from different relative signal strength levels is reduced.

Capacity in a TDMA system is increased by compressing the transmission signal into a shorter time slot. As a result, the information must be

- 3 -

transmitted at a correspondingly faster burst rate which increases the amount of occupied spectrum proportionally.

With FDMA or TDMA systems or hybrid FDMA/TDMA
5 systems, the goal is to insure that two potentially interfering signals do not occupy the same frequency at the same time. In contrast, Code Division Multiple Access (CDMA) allows signals to overlap in both time and frequency. Thus, all CDMA signals
10 share the same frequency spectrum. In the frequency or the time domain, the multiple access signals appear to be on top of each other.

There are a number of advantages associated with CDMA communication techniques. The capacity limits
15 of CDMA-based cellular systems are projected to be up to twenty times that of existing analog technology as a result of the properties of a wide band CDMA system, such as improved coding gain/modulation density, voice activity gating, sectorization and
20 reuse of the same spectrum in every cell. CDMA transmission of voice by a high bit rate decoder insures superior, realistic voice quality. CDMA also provides for variable data rates allowing many different grades of voice quality to be offered. The
25 scrambled signal format of CDMA completely eliminates cross talk and makes it very difficult and costly to eavesdrop or track calls, insuring greater privacy for callers and greater immunity from air time fraud.

In principle, in a CDMA system the informational
30 data stream to be transmitted is impressed upon a much higher rate data stream known as a signature sequence. Typically, the signature sequence data are binary, providing a bit stream. One way to generate this signature sequence is with a pseudo-noise (PN)
35 process that appears random, but can be replicated by

- 4 -

an authorized receiver. The informational data stream and the high bit rate signature sequence stream are combined by multiplying the two bit streams together, assuming the binary values of the two bit streams are represented by +1 or -1. This combination of the higher bit rate signal with the lower bit rate data stream is called coding or spreading the informational data stream signal. Each informational data stream or channel is allocated a unique spreading code.

A plurality of coded information signals modulate a radio frequency carrier, for example by quadrature phase shift keying (QPSK), and are jointly received as a composite signal at a receiver. Each of the coded signals overlaps all of the other coded signals, as well as noise-related signals, in both frequency and time. If the receiver is authorized then the composite signal is correlated with one of the unique codes, and the corresponding information signal can be isolated and decoded.

One CDMA technique, called "traditional CDMA with direct spreading", uses a signature sequence to represent one bit of information. Receiving the transmitted sequence or its complement (the transmitted binary sequence values) indicates whether the information bit is a "0" or "1". The signature sequence usually comprises N bits, and each bit is called a "chip". The entire N-chip sequence, or its complement, is referred to as a transmitted symbol. The receiver correlates the received signal with the known signature sequence of its own signature sequence generator to produce a normalized value ranging from -1 to +1. When a large positive correlation results, a "0" is detected; when a large negative correlation results, a "1" is detected.

- 5 -

Another CDMA technique, called "enhanced CDMA with direct spreading" allows each transmitted sequence to represent more than one bit of information. A set of code words, typically
5 orthogonal code words or bi-orthogonal code words, is used to code a group of information bits into a much longer code sequence or code symbol. A signature sequence or scramble mask is modulo-2 added to the binary code sequence before transmission. At the
10 receiver, the known scramble mask is used to descramble the received signal, which is then correlated to all possible code words. The code word with the largest correlation value indicates which code word was most likely sent, indicating which
15 information bits were most likely sent. One common orthogonal code is the Walsh-Hadamard (WH) code.

In both traditional and enhanced CDMA, the "information bits" referred to above can also be coded bits, where the code used is a block or
20 convolutional code. One or more information bits can form a data symbol. Also, the signature sequence or scramble mask can be much longer than a single code sequence, in which case a subsequence of the signature sequence or scramble mask is added to the
25 code sequence.

In many radio communication systems, the received signal includes two components, an I (in-phase) component and a Q (quadrature) component. This results because the transmitted signal has two
30 components, and/or the intervening channel or lack of coherent carrier reference causes the transmitted signal to be divided into I and Q components. In a typical receiver using digital signal processing, the received I and Q component signals are sampled every

- 6 -

T_c seconds, where T_c is the duration of a chip, and stored.

In mobile communication systems, signals transmitted between base and mobile stations typically suffer from echo distortion or time dispersion, caused by, for example, signal reflections from large buildings or nearby mountain ranges. Multipath dispersion occurs when a signal proceeds to the receiver along not one but many paths so that the receiver hears many echoes having different and randomly varying delays and amplitudes. Thus, when multipath time dispersion is present in a CDMA system, the receiver receives a composite signal of multiple versions of the transmitted symbol that have propagated along different paths (referred to as "rays") having relative time delays of less than one symbol period. Each distinguishable "ray" has a certain relative time of arrival $k T_c$ seconds and spans N of the I and Q chip samples, since each signal image is an N -chip sequence. As a result of multipath time dispersion, the correlator outputs several smaller spikes rather than one large spike. Each ray that is received after the symbol period (i.e., if the time delay caused by a reflection exceeds one symbol period) appears as an uncorrelated interfering signal that reduces the total capacity of the communication system. To optimally detect the transmitted symbols (bits), the spikes received must be combined. Typically, this is done by a RAKE receiver, which is so named because it "rakes" all the multipath contributions together.

A RAKE receiver uses a form of diversity combining to collect the signal energy from the various received signal paths, i.e., the various signal rays. Diversity provides redundant

- 7 -

communication channels so that when some channels fade, communication is still possible over non-fading channels. A CDMA RAKE receiver combats fading by detecting the echo signals individually using a correlation method and adding them algebraically (with the same sign). Further, to avoid intersymbol interference, appropriate time delays are inserted between the respective detected echoes so that they fall into step again.

10 In one form of RAKE receiver, correlation values of the signature sequence with the received signals at different time delays are passed through a delay line that is tapped at expected time delays (dt), the expected time between receiving echoes. The outputs
15 at the RAKE taps are then combined with appropriate weights. Such a receiver searches for the earliest ray by placing a tap at T_0 , and for a ray delayed by dt by placing a tap at T_0+dt , and so forth. The RAKE tap outputs having significant energy are
20 appropriately weighted and combined to maximize the received signal to noise and interference ratio. Thus, the total time delay of the delay line determines the amount of arrival time delay that can be searched.

25 A diagram of a conventional RAKE receiver using post-correlator, coherent combining of different rays is shown in Fig. 1. A received radio signal is demodulated by, for example, mixing it with cosine and sine waveforms and filtering the signal in an RF
30 receiver 1, yielding I and Q chip samples. These chip samples are buffered by a buffer which is composed of two buffers, one for the I (in-phase) samples 2a and one for the Q (quadrature) samples 2b. The bottom of each buffer 2a and 2b contains the most
35 recently received chip samples in time.

- 8 -

A multiplexer 3 receives the buffered chip samples and sends complex correlators 4a and 4b a range of I chip samples and the same range of Q chip samples. The range selected includes N samples
5 corresponding to the N-chip sequence arriving at a certain time. For example, if the I and Q buffers 2a and 2b, respectively, contain 159 chip samples (0-158), and N is 128, then the multiplexer 3 would send chip samples i through (i+127) from the I buffer 2a,
10 and chip samples i through (i+127) from the Q buffer 2b to correlator 4a, where i is the discrete time index of the signal rays from when the buffers were first filled.

A complex correlation value is formed by each
15 complex correlator 4a and 4b which correlate two sets of signal samples, I and Q, to the known signature sequence (code). Different complex correlators correspond to different received sample ranges, and hence different signal rays. The multiplexer 3 can
20 provide the received samples either serially or in parallel.

In general, a complex correlator correlates a complex input stream ($I+jQ$ samples) to a complex known sequence, producing a complex correlation
25 value. If the signature sequence is not complex, each complex correlator can be implemented as two scalar correlators in parallel, which is defined as a "half-complex" correlator. If the signature sequence is complex, the complex correlators correlate a
30 complex input to a complex sequence, giving rise to "full-complex" correlators. It is to be understood that the term "complex correlator" will be used herein to refer to each of the aforementioned scenarios.

- 9 -

Following correlation, the complex correlation values are transmitted to multiplier 5 where they are multiplied by a complex weight referred to as a complex RAKE tap. Each RAKE tap is a complex number consisting of a real part and an imaginary part. The complex correlator 4a correlates a set of data to a known signature sequence. Typically, only the real part of the product of the complex correlation values and the RAKE tap values are sent to accumulator 6. The accumulator 6 sums the weighted correlation results for all the signal rays processed and sends the accumulated result to a threshold device 7. The threshold device 7 detects a binary "0" if the input is greater than a threshold, or a binary "1" if the input is less than the threshold.

In mathematical terms, suppose $X(n) = I(n) + jQ(n)$ are the chip samples received by the receiver, where $I(n)$ are the I component samples, $Q(n)$ are the Q component samples, and n is the chip sample index corresponding to a respective discrete time. In Fig. 1, $I(n)$ are stored in 2a and $Q(n)$ are stored in 2b. The multiplexer 3, selects a range of I samples and a range of Q samples corresponding to the same ray. If $M(k,n) = M_I(k,n) + jM_Q(k,n)$ is the multiplexer output for ray k , giving N samples ($n=0, N-1$), then $M(k,n) = X(n+k)$ and $M_I(k,n) = I(n+k)$ and $M_Q(k,n) = Q(n+k)$.

The complex correlator, 4a, correlates the range of data samples from the multiplexer 3 to a known code sequence. Consider data samples $X(k), X(k+1), \dots, X(k+N-1)$, which are discrete time samples of the received data. If the receiver is trying to detect a code sequence $C(0), C(1), \dots, C(N-1)$, which consists of N values (usually ± 1 values), the correlator correlates some set of N data values with the N code sequence values as follows:

- 10 -

$$R(k) = X(k) C(0) + X(k+1) C(1) + \dots + X(k+N-1) C(N-1)$$

$$= \sum_{n=0}^{N-1} X(n+k) C(n)$$

where the index k indicates where to start in the data sequence. This corresponds to a relative time of arrival of the signal. Different arrival times correspond to different signal rays. Thus, ray k corresponds to a range of data values needed:
 5 $\{X(k), X(k+1), \dots, X(k+N-1)\}$. If N is large, then rays k and $k+1$ correspond to ranges which substantially overlap.

The computation of $R(k)$ can be performed by accessing
 10 the input data range in parallel or serially. Fig. 2 is representative of a parallel approach. A data buffer 53 stores consecutive time samples of the received signal, $X(n)$. Multiplexer 54 selects a range of N data values, $\{X(k), X(k+1), \dots, X(k+N-1)\}$,
 15 which are sent to the correlator 55. A multiplier 56 which corresponds to each input to the correlator, multiplies each input value with a corresponding coding sequence value. The products are summed together in adder 57 to form the correlation value
 20 $R(k)$.

Fig. 3 is representative of accessing the input range serially to compute $R(k)$. Input buffer 58 stores the received data samples. The buffer may be only one sample long, since only one sample at a time
 25 is correlated. If the buffer is more than one sample long, then a multiplexer 59 is needed to select a particular sample $X(k+i)$, where i is determined by control processor 60. The value selected is sent to correlator 61. The correlator 61 first computes the
 30 product of the input $X(k+i)$ with one element of the code sequence, $C(i)$, using multiplier 62. This

- 11 -

product is then added to an accumulator 64 which stores past products. Accumulator 64 is originally set to zero, then i is stepped from 0 to $N-1$, allowing the accumulation of N products. After N products have been accumulated, they are output from the correlator giving correlation value $R(k)$. Whether performing the correlation in parallel or serially, each data value $X(n)$ consists of b bits. The bits can be accessed and used all at once (parallel computation) or one at a time (bit serial approach).

Regardless of the correlation approach used, the correlator 4a for ray k correlates the multiplexer output $M(k,n)$ to the real code sequence $C(n)$, producing a complex correlation value $R(k) = R_I(k) + jR_Q(k)$ where:

$$R(k) = \sum_{n=0}^{N-1} M(k,n) C(n)$$

and

$$R_I(k) = \sum_{n=0}^{N-1} I(n+k) C(n)$$

$$R_Q(k) = \sum_{n=0}^{N-1} Q(n+k) C(n)$$

The RAKE combiner uses RAKE taps $W(k) = W_I(k) + jW_Q(k)$ to multiply the correlation values and accumulate the result into the decision statistic, Z where:

$$Z = \sum_{k} \operatorname{Re}\{W(k) R^*(k)\} = \sum_{k} W_I(k) R_I(k) + W_Q(k) R_Q(k)$$

- 12 -

The quantity Z is then thresholded in the threshold device 7 to determine whether a "0" or "1" was sent.

The conventional RAKE receiver is designed based on the assumption that for a given signal ray, there is signal energy in both the I and Q channels. In practice, this is not always the case. If all or most of the energy for a given signal ray is on the I channel then correlating both the I and Q channel is inefficient. This results in inefficient use of processing time, which might be better used elsewhere in the receiver. For a required level of performance, the conventional RAKE receiver requires more processing time than necessary. If processing time is limited, then a loss in utilized received signal power results, giving a loss in performance, i.e., increased detection errors.

The following example shows how the conventional RAKE receiver functions under two different scenarios. Suppose there are four signal rays, one line-of-sight ray and three echoes, which are combined with the complex weights (referred to as RAKE taps) given in TABLE 1.

TABLE 1
Rake Receiver Example

signal ray	amplitude	angle (deg)	I RAKE tap	Q RAKE tap
0	0.625	70	0.214	0.587
1	0.5	30	0.433	0.250
2	0.4677	40	0.358	0.301
3	0.375	10	0.369	0.065

The amplitude and angle represent the polar form of the RAKE taps, and the I and Q taps provide the Cartesian form used to multiply I and Q respectively. The energy in each signal ray is given by the

- 13 -

amplitude squared or by the sum of the I RAKE tap squared and Q RAKE tap squared. The amplitudes have been normalized so that the total signal power (sum of the amplitudes squared) is unity.

5 In the first scenario, suppose the RAKE receiver is limited to two RAKE taps, which would be used to combine the two strongest rays, rays 0 and 1. The energy in rays 2 and 3 would not be used in the detection process. The total signal power RAKE'd in
10 would be $0.625^2 + 0.5^2 = 0.214^2 + 0.587^2 + 0.433^2 + 0.250^2 = 0.64$ or 64% of the total signal power. An objective of the present invention is to increase the signal power used in the detection process, resulting in an increase in system performance.

15 In a second scenario, assume that the RAKE receiver is required to provide a certain performance level, which corresponds to RAKing in a certain percentage level of the signal energy, for example 75%, during detection. With a conventional RAKE
20 receiver, it is necessary to process three of the four rays. This requires a certain amount of computation, which corresponds to either a certain amount of hardware (three complex correlators) or a certain amount of processing time (one complex
25 correlator used three times). Another objective of the present invention is to achieve the same system performance level with less computation, which corresponds to either less hardware or less processing time which is later discussed herein.

30

SUMMARY OF THE INVENTION

The present invention solves the above-mentioned problems using a modified form of the RAKE receiver, referred to herein as a WRAKE receiver wherein the I and Q components are treated independently and the I

- 14 -

and Q taps from different rays are processed simultaneously. The WRAKE receiver includes means for receiving a composite signal of overlapping transmitted modulated carrier signals including at least two rays and for demodulating the composite signal to recover the transmitted symbols in each ray, means for sampling in-phase (I) and quadrature (Q) signals for each ray to produce I and Q samples for each transmitted symbol, means for selecting different groups of samples, each group including I or Q samples from one of said rays, means for correlating the grouped samples with known code sequences to generate correlation values, means for combining the correlation values and means to compare the combined correlation values with a threshold to determine each data symbol corresponding to each transmitted symbol. In one preferred embodiment only two groups of samples are selected where one group includes I samples and the other group includes Q samples.

In preferred embodiments the following can be used as correlation means: a single complex correlator, a set of complex correlators, a single scalar correlator and a set of scalar correlators. In another embodiment a means for computing a fast Walsh transform is used to correlate a set of known code sequences with the samples. A single code sequence can be non-orthogonal, orthogonal or bi-orthogonal with other code sequences associated with the same receivers or other receivers.

A further embodiment employs the RAKE receiver in a subtractive CDMA system. A descrambler is used to descramble each sample and then the correlation means correlates the descrambled samples with the code sequences. A detection means detects the

- 15 -

received code sequence. The detected signal is then subtracted from the composite signal leaving a residual composite signal which, if subtracted in the correlation domain, is inverse correlated and
5 rescrambled to produce the original composite signal less the detected signal. The residual composite signal is then recursively decoded until all the information signals have been extracted from the composite signal.

10 BRIEF DESCRIPTION OF THE DRAWINGS

The features and advantages of the invention will become apparent from reading the following detailed description in conjunction with the drawings, in which:

15 Fig. 1 is a functional schematic of a conventional RAKE receiver;

Fig. 2 is functional schematic of an exemplary parallel correlator;

20 Fig. 3 is functional schematic of an exemplary serial correlator;

Fig. 4 is a functional schematic of an embodiment of a WRAKE receiver according to the present invention;

25 Fig. 5 is a functional schematic of an embodiment of the multiplexer operation according to the present invention;

Fig. 6 is a functional schematic of another embodiment of the multiplexer operation according to the present invention;

30 Fig. 7 is a functional schematic of a further embodiment of a WRAKE receiver according to the present invention;

- 16 -

Fig. 8 is a functional schematic of another embodiment of the multiplexer operation of the present invention;

Fig. 9 is a functional schematic of a conventional RAKE receiver with prefiltering;

Fig. 10 is a functional schematic of an embodiment of a WRAKE receiver with prefiltering according to the present invention;

Fig. 11 is a functional schematic of a further embodiment of a WRAKE receiver according to the present invention; and

Fig. 12 is a functional schematic including further elements of the Fig. 11 embodiment.

DETAILED DESCRIPTION OF THE PREFERRED EMBODIMENTS

While the following description is in the context of cellular communications systems involving portable or mobile radio telephones and/or personal communication networks, it will be understood by those skilled in the art that the present invention may be applied to other communications applications.

The present invention, referred to as a WRAKE receiver, combines signal energy in a manner different from conventional RAKE receivers. Rather than treating the signal energy components as signal rays with I and Q components, the WRAKE receiver treats the components at a lower level, referred to as "waves", where each wave has a signal ray number and a channel specification (I or Q).

For example, the strongest wave in the aforesaid TABLE 1 example is on signal ray 0, the Q channel (having weight 0.587). Shown in TABLE 2 are the waves in decreasing energy order for the example in TABLE 1.

- 17 -

TABLE 2
WRAKE View of Signal Components

wave	signal ray	channel	weight
0	0	Q	0.587
1	1	I	0.433
2	3	I	0.369
3	2	I	0.358
4	2	Q	0.301
5	1	Q	0.250
6	0	I	0.214
7	3	Q	0.065

When combining signal energy components at the wave level, one strategy is to combine waves containing the most signal energy. Since there are twice as many waves as there are rays, this approach might appear inefficient. However, because a complex correlator can perform two correlations in parallel, two waves can be processed together in the same complex correlator. Unlike the conventional RAKE receiver of Fig. 1, these waves need not come from the same signal ray (i.e., the waves processed together can arrive at different times) and these waves do not have to come from two different channels (i.e., they could both be from either the I or Q channel). A pair of waves processed by the same complex correlator is defined as a "wray".

The present invention processes the waves which contain the most signal energy. For example, the strongest wave can be processed with the next strongest wave in the same complex correlator, etc. This particular method of WRAKE pairing need not be used, so long as the strongest waves are processed. TABLE 3 shows the aforementioned method of pairing

where the strongest wave is processed with the next strongest wave. Each pair is referred to as a "wray".

TABLE 3
WRAKE Pairing

5

signal "wray"	first component	second component
0	wave 0	wave 1
1	wave 2	wave 3
2	wave 4	wave 5
3	wave 6	wave 7

10

In the example used, the conventional RAKE limited to two complex correlations processed 64% of the signal energy. The WRAKE receiver, also limited to two complex correlations, would process "wrays" 0 and 1. Thus, the total signal energy included would be (see TABLES 2 and 3) $0.587^2 + 0.433^2 + 0.369^2 + 0.358^2 = 0.796$ or 79.6% of the total signal power. Thus, for this example, the increase over the conventional system in signal energy collected is 15.6% of the total energy available. There are other examples which can be constructed where the increase in signal energy collected is even greater. Thus, when the number of complex correlations performed is limited, the WRAKE receiver collects more of the signal energy, providing better receiver performance.

25

With the same example, suppose a performance requirement determines the number of complex correlations performed. If the performance requirements of the system results in the requirement that 75% of the signal energy be collected, the performance criterion is met with only two complex correlations. Actually in this example, the WRAKE receiver collects 79% of the energy with only two complex correlations. As a result, there is either a

30

- 19 -

reduction in hardware or processing time over the conventional RAKE receiver which requires three complex correlations to meet the performance criterion.

- 5 The mathematical value of the decision statistic Z from the discussion of the conventional RAKE can be manipulated to distinguish the conventional RAKE and the WRAKE of the present invention. From the conventional RAKE:

$$Z = \sum_k \operatorname{Re}\{W(k)R^*(k)\} = \sum_k W_I(k)R_I(k) + W_Q(k)R_Q(k)$$

- 10 The expression is equivalent to:

$$Z = \sum_k W_I(k)R_I(k) + \sum_k W_Q(k)R_Q(k)$$

- Some of the component taps in each summation may be zero or quantized to zero since $W(k) \neq 0 + j0$ means that at least one component of $W(k)$ is nonzero, but not necessarily both. Computing the corresponding correlation value would be a waste of computation resources, since it would then be multiplied by zero. Accordingly for the WRAKE receiver, only component correlations which are weighted by nonzero component tap values are computed. When the RAKE receiver is limited to a certain number of RAKE taps, L, there is a limitation on the number of rays that can be combined in the conventional RAKE. To optimize performance, the L rays with the highest RAKE tap magnitudes or magnitudes squared are used. If k^i ,
- 15
- 20

- 20 -

where $i=0, \dots, L-1$ correspond to these rays then Z for a conventional RAKE is:

$$Z = \sum_{i=0}^{L-1} W_I(k^i) R_I(k^i) + \sum_{i=0}^{L-1} W_Q(k^i) R_Q(k^i)$$

$$= \sum_{i=0}^{L-1} W_I(k^i) R_I(k^i) + W_Q(k^i) R_Q(k^i)$$

The WRAKE receiver combines more signal energy in two ways. First, the same ray for each component combined in parallel does not have to be used, and, second, different components (I and Q) in parallel need not be combined. For example, when $i=1$ in the previous summation, the WRAKE receiver could combine ray 1, I component with ray 2, I component.

Mathematically, the WRAKE receiver forms:

$$Z = \sum_{i=0}^{L-1} W_{c_1^i}(k_1^i) R_{c_1^i}(k_1^i) + W_{c_2^i}(k_2^i) R_{c_2^i}(k_2^i)$$

where c_1^i and c_2^i represent which component, I or Q, k_1^i and k_2^i represent which ray, and i indicates which "wray". Unlike the conventional RAKE, c_1^i and c_2^i do not have to be different and k_1^i and k_2^i do not have to be the same. In the conventional RAKE, Z consisted of a sum of ray contributions, corresponding to a particular ray index k and a pair of different components I and Q. The WRAKE however, combines "wrays", each consisting of two components c_1 and c_2 not necessarily different and associated rays k_1 and k_2 not necessarily the same.

The present invention will now be described with reference to a block diagram shown in Fig. 4. Like the conventional RAKE receiver, a radio signal is

- 21 -

received by a receiver 11 and sampled, producing chip samples $I(n)$ and $Q(n)$. These chip samples are buffered in a buffer, which can be viewed as two buffers, one for $I(n)$ samples 12a, and one for $Q(n)$ samples 12b.

The buffered chip samples are passed to a multiplexer 13. The multiplexer 13 selects two independent ranges of chip samples. The chip samples selected can come from the same or different channels. Let $M(k_1, c_1, k_2, c_2, n)$ denote the output of multiplexer 13 for a "wray", consisting of two sample ranges, one from component c_1 one from component c_2 , where c_1 is either I or Q and c_2 is either I or Q . All four combinations, (I, I) , (I, Q) , (Q, I) , and (Q, Q) , of c_1 and c_2 are possible. However, some combination are nonsensical. For example, if $c_1=c_2$, it does not make sense for $k_1=k_2$ because this result would correspond to RAKing in the same signal energy twice. The range of samples from component c_1 corresponds to ray k_1 and the range from component c_2 corresponds to ray k_2 . The values of k_1 and k_2 are not necessarily the same. The output of the multiplexer is given by:

$$M(k_1^i, c_1^i, k_2^i, c_2^i, n) = c_1^i(n + k_1^i) + jc_2^i(n + k_2^i)$$

The multiplexer outputs are correlated to a known sequence in complex correlators 14a and 14b. For a "wray" i , the output of correlator 14a is:

$$R_{c_1^i}(k_1^i) + jR_{c_2^i}(k_2^i) = \sum_{n=0}^{N-1} M(c_1^i, k_1^i, c_2^i, k_2^i, n) C(n)$$

The output of the correlators 14a and 14b are multiplied by complex weights in multipliers 15. Typically, only the real part of the product is needed, which can be obtained by two scalar

- 22 -

multipliers and an adder. This is referred to as a "half-complex" multiplier. However, there are cases where a true complex multiplier, referred to as a "full-complex" multiplier, is needed. For example, if two signals are sent on carriers with a phase difference of ninety degrees, they can be demodulated together if a full-complex multiplier is used. It is to be understood that the term complex multipliers when used herein is referring to either half-complex or full-complex multipliers. Another possibility is that the code sequence is complex, which corresponds to the case where the I channel signature sequence and the Q channel signature sequence are different. In this case $C^*(n)$ should be used in the equation for the correlator output above.

Next the products are sent to an accumulator where they are accumulated. The accumulated result is:

$$Z = \sum_i^{N_{c_1^i(k_1^i)} + jN_{c_2^i(k_2^i)} + 0 + j0} \text{Re}\{(W_{c_1^i}(k_1^i) + jW_{c_2^i}(k_2^i)) (R_{c_1^i}(k_1^i) - jR_{c_2^i}(k_2^i))\}$$

or

$$Z = \sum_i^{N_{c_1^i(k_1^i)} + jN_{c_2^i(k_2^i)} + 0 + j0} W_{c_1^i}(k_1^i) R_{c_1^i}(k_1^i) + W_{c_2^i}(k_2^i) R_{c_2^i}(k_2^i)$$

The decision statistic Z is passed to a threshold decision device which determines the received binary information bit by comparing the accumulated result with a predetermined threshold.

In general, all the correlations can be performed in parallel (as shown in FIG. 4) or in series, using the same correlators more than once. The number and type (complex versus scalar) of correlators available determines the number of

- 23 -

received sample ranges the multiplexer must provide (one set per "wave" correlated). Thus, the multiplexer of the WRAKE receiver must provide one range of data values (a single scalar correlator),
5 two ranges of data values (a single complex correlator or two scalar correlators), or more (more than two scalar correlators or more than one complex correlator) ranges of data values from the data buffer to the correlator(s). An increase in the
10 ranges in parallel is accompanied by an increase in circuitry needed for the multiplexer.

If only one range is required, for example when a single scalar correlator is used, then the multiplexer is straightforward. A simple example of
15 this embodiment is shown in Fig. 5 where each channel buffer is three samples long, and the range of samples required (i.e., the length of the information sequence to which the data are being correlated) is two. If the three complex samples are represented by
20 $I(n) + jQ(n)$, where n is the discrete time index, there are four possible ranges of data values: $I(1)$ through $I(2)$, $I(2)$ through $I(3)$, $Q(1)$ through $Q(2)$, and $Q(2)$ through $Q(3)$. These values are stored by channel in buffers 43a and 43b. One of the four
25 possible ranges is selected by the multiplexer 44 where control bits c_1 and c_2 select the starting time and the channel respectively. The selected range is then sent to scalar correlator 45.

There are several ways to provide more than one
30 range, not necessarily from different channels. For example, if all multiplexer outputs are provided in parallel, then one "brute force" method for providing more than one range is to duplicate the multiplexer of Fig. 5, as shown in Fig. 6. The data buffers 46a
35 and 46b are connected to the multiplexer 47 which

- 24 -

includes multiplexers 48a and 48b, each providing a different range of possibly overlapping data values. The two ranges of data values are sent to two different scalar correlators 50a and 50b.

5 The total number of correlations performed depends on the number of wrays which is related to the number of echoes. As the receiver moves with respect to the transmitter, the number of waves will vary and hence the number of correlations actually
10 performed will vary with time. For example, during one time period a single wave might be processed while during a different time period multiple waves may be processed.

 The WRAKE receiver can be adapted to other forms
15 of channel diversity. For example, if antenna diversity is present, then there would be multiple I and Q channels. The WRAKE would still process the strongest waves, independently of the signal ray, I/Q channel, and antenna from which the waves originated.
20 Also, by using full-complex multipliers instead of half-complex multipliers, the WRAKE receiver can demodulate in parallel two signals whose carriers are separated by ninety degrees. Other forms of channel
25 diversity include, but are not limited to, frequency diversity (sending the same message on different frequency channels), time diversity (sending the same message at different times), explicit path or space
30 diversity (sending the message purposely on different paths, usually using different transmitting and/or receiving antennas), and polarization diversity.

 An alternate preferred embodiment replaces the multiple correlators shown in Fig. 4 with one complex correlator. In this configuration, the single complex correlator is used multiple times, and the
35 results are accumulated. As compared to a

- 25 -

conventional receiver, if the single complex correlator is used the same number of times, the complex correlator of the WRAKE would process more signal energy than the conventional RAKE. Thus, for
5 a given performance level the WRAKE uses the single complex correlator fewer times, saving processing time.

In the discussion above, the WRAKE receiver is configured to process pairs of ranges either in
10 parallel or in series. If scalar correlators are used (scalar sample by sample multipliers in the pre-filtering WRAKE case), then ranges are actually processed one at a time, allowing for the total number of processed ranges to be even or odd. Thus,
15 if the number of waves is odd, the number of ranges processed exactly equals the number of waves. If the WRAKE receiver is configured to process pairs of ranges, and the number of waves is odd, then the last wave could be paired with an arbitrary range to
20 complete a "wray", and the weight associated with the arbitrary range would be set to zero. In general, the WRAKE receiver can be configured to process J ranges of data in parallel, possibly allowing results from multiple sets of J ranges to be accumulated. If
25 the number of waves is not a multiple of J, then either extraneous processing elements are fed with zeroes, or they are fed with arbitrary ranges, whose results are weighted by zero.

Limited WRAKE

30 Another preferred embodiment of the present invention called a limited WRAKE receiver is shown in Fig. 7. Like elements in Fig. 7 function the same as the elements in Fig. 4 except as mentioned below. The limited WRAKE receiver differs from a regular

WRAKE receiver because the complex correlator of a limited WRAKE receiver must receive a range of I values and a range of Q values. The ranges are still independent, but in contrast to the WRAKE receiver, the two ranges in a limited WRAKE receiver must come from different channels. The multiplexer 13 still selects independent ranges from the I and Q channels as shown in Fig. 7.

The limited WRAKE receiver processes the strongest I waves and the strongest Q waves, but the I waves must be paired with Q waves. Following the example discussed above, TABLE 4 shows the results of pairing the strongest I wave with the strongest Q wave, and so on.

TABLE 4
Limited WRAKE pairing

signal "wray"	I component	Q component
0	wave 1	wave 0
1	wave 2	wave 4
2	wave 3	wave 5
3	wave 6	wave 7

Processing the two strongest "wrays" yields $0.433^2 + 0.587^2 + 0.369^2 + 0.301^2 = 0.759$ or 75.9% of the total signal energy. In this example, the limited WRAKE receiver provides 11.9% more signal energy than the conventional RAKE receiver. Also, to meet a performance criterion of 75%, the signal energy processed by the limited WRAKE receiver requires only two complex correlations. Thus, the limited WRAKE is still an improvement over the conventional RAKE receiver

One of the motivations for the limited WRAKE approach is that the multiplexers become simpler,

- 27 -

particularly if only one complex correlator, i.e., two scalar correlators, is used. In this case, two standard multiplexers are required, one for the I channel and one for the Q channel. The control of each is independent, allowing independent ranges of values to be selected.

Another method to multiplexing, particularly useful in the limited WRAKE approach, uses the input buffer to provide range selection as shown in Fig. 8. The I and Q data buffers are independent shift registers, shifting the data into position for access by a set of connections to a fixed range of data buffer locations. The I and Q buffers 51a and 51b are such shift registers. When a single shift upwards is commanded, the contents in position D move to position C, the contents in position C move to position B, and so forth. With the contents shown in Fig. 8, the range I(1) through I(2) is selected for correlation as is the range Q(1) through Q(2). To select different ranges, say, I(2) through I(3) and Q(1) through Q(2), the I buffer would be shifted upwards once and the Q buffer would remain unchanged.

Pre-filtering WRAKE

The order of processing the received signal in the RAKE receiver can be altered. Fig. 9 shows a conventional RAKE receiver in which the chip samples are filtered using the RAKE taps, then correlated to a known sequence. In such an implementation only one scalar correlator is needed.

Another preferred embodiment of the present invention is a WRAKE with pre-filtering as shown in Fig. 10. A radio signal is received by the receiver 21 which produces quantized chip samples for the I and Q channels. These samples are buffered in a

- 28 -

buffer, which can include two buffers, one for I samples 22a, and one for Q samples 22b.

The buffered chip samples are passed to a multiplexer 23. In the conventional RAKE receiver with pre-filtering of Fig. 9, the multiplexer 23 provides the sample by sample multiplier 24 with a range of I values and the same range of Q values. The multiplier 24 can include a series of sample by sample multipliers as shown in Fig. 9 or simply a single sample by sample multiplier used multiple times. The multiplier 24 takes each sample $I + jQ$ and multiplies it by a complex weight, computing only the real part of the product. Thus, if the input to the multiplier is N I samples and N Q samples, the output is N scalar samples.

In the WRAKE receiver shown in Fig. 10, the multiplexer 23 provides one range of I or Q values and another range of I or Q values to the sample-by-sample multiplier 24. The multiplier multiplies each chip sample by a complex weight, computing either the full-complex product or only the real part of the product. If only the real part of the product is required, then the complex sample-by-sample multiplier can be implemented as two scalar sample-by-sample multipliers followed by an accumulator. If only one scalar sample-by-sample multiplier is available, then it can be used twice to realize the product. The accumulator function can be provided by the adder 25.

The sample-by-sample adder 25 adds the results from multiple sample-by-sample multipliers of multiplier 24 and passes the result to scalar correlator 26. If a single sample-by-sample multiplier is used multiple times, then the sample-by-sample adder accumulates the results before

- 29 -

passing them on to the scalar correlator 26. The scalar correlator 26 correlates the result with a known signature sequence. The correlation result is sent to a threshold decision device 27. The

5 threshold decision device 27 compares the correlated result with a threshold to determine the data sent. If the sample-by-sample complex multipliers 24a and 24b produce complex outputs, then 26 would be a complex correlator, correlating the real samples to

10 one sequence and the imaginary samples to another sequence (e.g., for detection of two signals simultaneously, where the two signals were transmitted with carriers ninety degrees apart).

Several advantages are realized by the

15 prefiltered WRAKE receiver of the present invention. For example, with a fixed number of sample-by-sample complex multipliers, the WRAKE collects more signal energy than the conventional RAKE. Also, with a fixed performance level, the WRAKE requires fewer

20 sample-by-sample complex multipliers. Thus, when a single sample-by-sample multiplier is used multiple times, the WRAKE receiver uses the complex multiplier fewer times, reducing processing time.

WRAKE Receiver in a Subtractive CDMA System

25 In another preferred embodiment of the present invention a WRAKE receiver is used in a subtractive CDMA system of the type described in U.S. Patent No. 5,151,919, entitled "CDMA Subtractive Demodulation" by Paul W. Dent and the corresponding Continuation-

30 In-Part, U.S. Patent Application Serial No. 739,446. A block diagram of the present WRAKE receiver used in a subtractive CDMA system is shown in Fig. 11.

Similar to the WRAKE receiver of Fig. 4, a composite signal is received by a receiver 31 and

- 30 -

sampled, producing I and Q chip samples. The samples are buffered in a buffer, which includes two buffers 32a, 32b for I samples and Q samples, respectively. Using the regular WRAKE approach, the multiplexer 33
5 selects two ranges of samples, not necessarily corresponding to different components (I and Q). Using the limited WRAKE approach, the multiplexer 33 selects a range of I samples and a range of Q samples. In both cases, the sample ranges selected
10 are independent of each other.

A descrambler 34 removes one scrambling code from the samples either by inverting each chip sample or not, depending on the bit polarity of the scrambling code. Next the samples are transferred in
15 parallel to a single correlator 35 which simultaneously correlates the samples with several known code sequences using a fast Walsh transform algorithm. Each sequence correlation result is then multiplied by a complex weight in multiplier 36 and
20 the results are individually accumulated in accumulator 37.

To accumulate multiple wrays, the multiplexer windows are moved and the correlation, weighting, and accumulation processes are repeated. Finally, a
25 decision device 38 determines the largest accumulated result. The index of the largest accumulated result indicates which sequence was detected and thus the signal decoded.

Next, subtraction of the coded signal having
30 just been detected occurs; the process is depicted in Figs. 11 and 12. Similar to the detection process, the multiplexer selects a range of I samples and a range of Q samples where signal energy is present. These ranges are both descrambled in 34 and sent
35 through the correlator 35. Instead of sending the

- 31 -

correlator outputs to the complex multipliers, as in Fig. 11, the correlator outputs are sent to a gating device 39 as shown in Fig. 12. From the previously performed detection process, the output of the decision device 38 determines which complex correlation value is set to zero by opening the corresponding switch in gating device 39. The gating device 39 allows all values to pass through except for the line corresponding to the index detected previously. This is done by closing all but one switch. The line not closed effectively passes a zero value. Thus, the line corresponding to the largest correlation value, as determined by decision device 38, is set to zero by opening the corresponding switch in 39. In this manner one image of the decoded signal is subtracted from the composite signal. As depicted in Fig. 12, the remaining spectrum of the composite signal with one component removed is processed in an inverse fast Walsh transform circuit 40 and rescrambled by a rescrambler 41 with the same scrambling code to reconstruct the original signal samples minus the just-subtracted signal image. The output of the rescrambler 41 is used to overwrite the original data in the I and Q buffers 32. The process is repeated for other ranges of I and Q samples until all or most of the signal energy is removed. Thus, each information signal is removed from the composite signal after it has been decoded.

The correlation values not passed by the gating device 39 are sent instead to sorting processor 42, which combines these values from different echoes to form an estimate of the signal strength. The sorting processor 42 then orders the signal strengths and associated scrambling codes from greatest to weakest.

- 32 -

The code corresponding to the greatest magnitude is transmitted to the descrambler 34 for signal demodulation first. This method of ordering is preferred over other methods because interference is minimized by decoding the strongest signal and then subtracting that signal from the composite signal. Once the strongest signal is removed from the composite signal, the next strongest signal may be readily detected without having to account for the interference of the strongest signal.

The residual, composite signal having a first decoded signal removed according to the subtractive demodulation technique is descrambled again by descrambler 34 using the descrambling code of the second signal to be decoded and passed to correlator 35 to be correlated by a second fast Walsh transform for decoding and so on. The order in which signals are decoded and subtracted is governed by the order in which the descrambling codes are used, which in a preferred embodiment are in descending order of the signal strengths.

The contribution of unwanted signals (e.g., interfering) can be further minimized if the digital spreading codes are orthogonal. Two codes are orthogonal if exactly one half of their bits are different. Additionally, bi-orthogonal codes where the code words and their complements are used may be used as digital spreading codes so that an additional bit of information may be conveyed per codeword. It will be understood that only a certain number of orthogonal code words exist for a finite word length and that orthogonality can be maintained only if the relative time alignment between two signals is strictly maintained. The fast Walsh transform, where all the spreading codes may be simultaneously

- 33 -

correlated, efficiently uses orthogonal block code words.

Implementation of the WRAKE filtering operations shown in Figs. 4, 7, 10 and 11 can be done in several
5 ways. The operations can be implemented directly in hardware, using VLSI technology. An alternative is to implement some or all of the operations in a multi-purpose programmable processor, such as a micro-processor or a Digital Signal Processor (DSP).
10 In this embodiment, multiplexing becomes memory accessing with certain addresses. Correlating and multiplication can be performed in the arithmetic logic unit (ALU) of the processor, using registers or other memory to accumulate results.

15 While particular embodiments of the present invention have been described and illustrated, it should be understood that the invention is not limited thereto since modifications may be made by persons skilled in the art. The present application
20 contemplates any and all modifications that fall within the spirit and scope of the underlying invention disclosed and claimed herein.

- 34 -

CLAIMS:

1. In a spread spectrum communications system wherein a transmitter transmits a data signal to a receiver, said receiver comprising:

5 means for receiving at least two rays of the data signal, wherein the receiving means produces in-phase (I) and quadrature (Q) components for each ray;

means for sampling said I and Q components to produce at least one I sample and at least one Q
10 sample for each ray;

means for selecting at least two wrays of said samples, each wray including I samples or Q samples from any one of said rays; and

means for combining said samples in each of said
15 selected wrays to recover the transmitted data signal.

2. In a code division multiple access system for communicating a sequence of data symbols to a receiver, wherein a transmitter combines each data
20 symbol with a known code sequence to form a respective transmitted symbol, said receiver comprising:

means for receiving a composite signal of overlapping modulated carrier signals including at
25 least two rays and for demodulating the composite signal to recover the transmitted symbols in each ray, the receiving and demodulating means producing in-phase (I) and quadrature (Q) components for each ray;

30 means for sampling said I and Q components to produce at least one I sample and at least one Q sample for each transmitted symbol;

- 35 -

means for selecting at two ways of said samples, each way including I samples or Q samples from any one of said rays;

means for correlating said samples in each of
5 said selected ways to a known code sequence and generating correlation values;

means for combining said correlation values to generate a combined value; and

means for comparing said combined value with a
10 threshold to determine each data symbol corresponding to each transmitted symbol.

3. The system according to claim 2 wherein said selecting means selects said samples from two different ways, a first way including I samples
15 from one of said rays and a second way including Q samples from one of said rays.

4. The system according to claim 2 wherein the combining means includes:

means for multiplying each correlation value by
20 a corresponding weight to produce a plurality of weighted values; and

means for summing the weighted values to generate said combined value.

5. The system according to claim 2 wherein the
25 correlation means includes a single complex correlator for correlating each selected way with said known code sequence.

6. The system according to claim 2 wherein the
30 correlation means includes a single scalar correlator for correlating each selected way with said known code sequence.

- 36 -

7. The system according to claim 2 wherein the correlation means includes a plurality of complex correlators for correlating each selected wray with said known code sequence.

5 8. The system according to claim 2 wherein the correlation means includes a plurality of scalar correlators for correlating each selected wray with said known code sequence.

9. In a code division multiple access system
10 for communicating a sequence of data symbols to a receiver, wherein a transmitter combines each data symbol with a known code sequence to form a respective transmitted symbol, said receiver comprising:

15 means for receiving a composite signal of overlapping modulated carrier signals including at least two rays and for demodulating the composite signal to recover the transmitted symbols in each ray, the receiving and demodulating means producing
20 in-phase (I) and quadrature (Q) components for each ray;

 means for sampling said I and Q components to produce at least one I sample and at least one Q sample for each transmitted symbol;

25 means for selecting at least two wrays of said samples, each wray including I samples or Q samples from any one of said rays;

 means for combining said samples in each of said selected wrays to generate groups of combined
30 samples;

 means for correlating said groups of combined samples with a known code sequence and generating a correlation value; and

- 37 -

means for comparing said correlation value with a threshold to determine each data symbol corresponding to each transmitted symbol.

10. The system according to claim 9 wherein
5 said selecting means selects said samples from two different wrays, a first wray including I samples from one of said rays and a second wray including Q samples from one of said rays.

11. The system according to claim 9 wherein the
10 combining means includes:

means for multiplying each sample by a corresponding weight to produce a plurality of weighted values; and

15 means for summing the weighted values to generate said groups of combined samples.

12. The system according to claim 11 wherein the multiplying means includes a single complex sample-by-sample multiplier for multiplying each sample by said corresponding weight.

20 13. The system according to claim 11 wherein the multiplying means includes a single scalar sample-by-sample multiplier for multiplying each sample by said corresponding weight.

25 14. The system according to claim 11 wherein the multiplying means includes a plurality of complex sample-by-sample multipliers for multiplying each sample by said corresponding weight.

15. The system according to claim 11 wherein the multiplying means includes a plurality of scalar

- 38 -

sample-by-sample multipliers for multiplying each sample by said corresponding weight.

16. In a code division multiple access system for communicating data symbols to a receiver, wherein
- 5 a transmitter maps a stream of data symbols into a stream of code symbols and further combines each code symbol with one scrambling bit sequence to form a stream of respective transmitted scrambled code symbols, the receiver comprising:
- 10 means for receiving a composite signal of overlapping modulated carrier signals including at least two rays and for demodulating the composite signal to recover the transmitted scrambled code symbols in each ray, the receiving and demodulating
- 15 means producing in-phase (I) and quadrature (Q) components for each ray;
- means for sampling the I and Q components to produce at least one I sample and at least one Q sample for each transmitted scrambled code symbol;
- 20 means for successively selecting at least two wrays of said samples, each wray including I samples or Q samples from any one of said rays;
- means for successively descrambling each wray of samples with the scrambling bit sequence;
- 25 means for successively correlating the descrambled samples in the selected wrays with a set of known code sequences and generating correlation values;
- means for successively combining said
- 30 correlation values to generate combined values; and
- means for successively comparing the combined values with each other to detect each transmitted scrambled code symbol, said detected scrambled code symbols corresponding to said stream of data symbols.

- 39 -

17. The system according to claim 16 wherein
said selecting means successively selects said
samples from two different wrays, a first wray
including I samples from one of said rays and a
5 second wray including Q samples from one of said
rays.

18. The system according to claim 16 further
including:

means for successively removing a selected one
10 of said code symbols corresponding to the detected
one of said code symbols from the composite signal to
generate a residual composite signal; and

means for successively reconstructing the
original composite signal samples less the selected
15 code symbol from the residual composite signal and
transmitting the samples to the selecting means.

19. The system according to claim 18 wherein
said reconstructing means further includes:

means for inverse correlating the residual
20 composite signal; and

means for rescrambling the residual composite
signal to reconstruct the original composite signal
without the code symbol corresponding to the detected
code symbol using said scrambling bit sequence.

25 20. The system according to claim 19 wherein
said correlating means includes means for computing a
fast Walsh transform to correlate the samples to
known Walsh-Hadamard sequences and said inverse
correlating means includes means for computing an
30 inverse fast Walsh transform to reconstruct samples
of the residual composite signal.

- 40 -

21. The system according to claim 18 wherein said comparing means determines which combined value is the largest, and said removing means removes the code symbol, corresponding to the largest correlation value, from the composite signal to form the residual composite signal.

22. The system according to claim 16 wherein the correlation means includes means for computing a fast Walsh transform to correlate the samples to known Walsh-Hadamard sequences.

23. A system according to claim 16 wherein said set of known code sequences are code words from an orthogonal block code.

24. A system according to claim 16 wherein said set of known code sequences are code words from a bi-orthogonal block code.

25. In a code division multiple access system for communicating data symbols to a receiver, wherein a transmitter maps a stream of data symbols into a stream of code symbols and further combines each code symbol with one scrambling bit sequence to form a stream of respective transmitted scrambled code symbols, the receiver comprising:

means for receiving a composite signal of overlapping modulated carrier signals including at least two rays and for demodulating the composite signal to recover the transmitted scrambled code symbols in each ray, the receiving and demodulating means producing in-phase (I) and quadrature (Q) components for each ray;

- 41 -

means for sampling the I and Q components to produce at least one I sample and at least one Q sample for each transmitted scrambled code symbol;

means for successively selecting at least two
5 wrays of said samples, each wray including I samples or Q samples from any one of said rays;

means for successively descrambling each wray of samples with the scrambling bit sequence;

means for successively combining said
10 descrambled wrays of samples to generate groups of combined samples; and

means for successively correlating said groups of combined samples with a set of known code sequences and generating a plurality of correlation
15 values, one for each sequence; and

means for successively comparing the correlation values with each other to detect each transmitted scrambled code symbol, said detected scrambled code symbols corresponding to said stream of data symbols.

20 26. The system according to claim 25 wherein said selecting means selects said samples from two different wrays, a first wray including I samples from one of said rays and a second wray including Q samples from one of said rays.

25 27. The system according to claim 25 wherein the correlation means includes means for computing a fast Walsh transform to correlate the samples to known Walsh-Hadamard sequences.

30 28. A system according to claim 25 wherein said set of known code sequences are code words in an orthogonal block code.

- 42 -

29. A system according to claim 25 wherein said set of known code sequences are code words in a bi-orthogonal block code.

30. In a code division multiple access system,
5 a method for communicating a sequence of data symbols to a receiver, wherein a transmitter combines each data symbol with a known code sequence to form a respective transmitted symbol, said method comprising the steps of:

10 receiving a composite signal of overlapping modulated carrier signals including at least two rays;

demodulating the composite signal to recover the transmitted symbols in each ray, producing in-phase
15 (I) and quadrature (Q) components for each ray;

sampling said I and Q components to produce at least one I sample and at least one Q sample for each transmitted symbol;

20 selecting at least two ways of said samples, each way including I samples or Q samples from any one of said rays;

correlating said samples in each of said selected ways to a known code sequence and generating correlation values;

25 combining said correlation values to generate a combined value; and

comparing said combined value with a threshold to determine each data symbol corresponding to each transmitted symbol.

30 31. The method according to claim 30 wherein said step of selecting includes the step of selecting said samples from two different ways, a first way including I samples from one of said rays and a

- 43 -

second wray including Q samples from one of said rays.

32. The method according to claim 30 wherein said step of combining further includes the steps of:

5 multiplying each correlation value by a corresponding weight to produce a plurality of weighted values; and

summing the weighted values to generate said combined value.

10 33. The method according to claim 30 wherein the step of correlating includes correlating each selected wray with said known code sequence using a single complex correlator.

15 34. The method according to claim 30 wherein the step of correlating includes correlating each selected wray with said known code sequence using a single scalar correlator.

20 35. The method according to claim 30 wherein the step of correlating includes correlating each selected wray with said known code sequence using a plurality of complex correlators.

25 36. The method according to claim 30 wherein the step of correlating includes correlating each selected wray with said known code sequence using a plurality of scalar correlators.

37. In a code division multiple access system, a method for communicating a sequence of data symbols to a receiver, wherein a transmitter combines each data symbol with a known code sequence to form a

- 44 -

respective transmitted symbol, said method comprising the steps of:

- receiving a composite signal of overlapping modulated carrier signals including at least two rays;
- 5 demodulating the composite signal to recover the transmitted symbols in each ray, producing in-phase (I) and quadrature (Q) components for each ray;
- sampling said I and Q components to produce at least one I sample and at least one Q sample for each transmitted symbol;
- 10 selecting at least two wrays of said samples, each wray including I samples or Q samples from any one of said rays;
- 15 combining said wrays of samples to generate groups of combined samples;
- correlating said groups of combined samples with a known code sequence and generating a correlation value; and
- 20 comparing said correlation value with a threshold to determine each data symbol corresponding to each transmitted symbol.

38. The method according to claim 37 wherein said step of selecting includes the step of selecting said samples from two different wrays, a first wray including I samples from one of said rays and a second wray including Q samples from one of said rays.

39. The method according to claim 37 wherein said step of combining further includes the steps of:

30 multiplying each sample by a corresponding weight to produce a plurality of weighted values; and

- 45 -

summing the weighted values to generate said groups of combined samples.

40. The method according to claim 39 wherein the step of multiplying includes multiplying each sample by said corresponding weight using a single complex sample-by-sample multiplier.

41. The method according to claim 39 wherein the step of multiplying includes multiplying each sample by said corresponding weight using a single scalar sample-by-sample multiplier.

42. The method according to claim 39 wherein the step of multiplying includes multiplying each sample by said corresponding weight using a plurality of complex sample-by-sample multipliers.

43. The method according to claim 39 wherein the step of multiplying includes multiplying each sample by said corresponding weight using a plurality of scalar sample-by-sample multipliers.

44. In a code division multiple access system, a method for communicating data symbols to a receiver, wherein a transmitter maps a stream of data symbols into a stream of code symbols and further combines each code symbol with one scrambling bit sequence to form a stream of respective transmitted scrambled code symbols, the method comprising the steps of:

receiving a composite signal of overlapping modulated carrier signals including at least two rays and demodulating the composite signal to recover the transmitted scrambled code symbols in each ray,

- 46 -

producing in-phase (I) and quadrature (Q) components for each ray;

5 sampling the I and Q components to produce at least one I sample and at least one Q sample for each transmitted scrambled code symbol;

successively selecting at least two wrays of said samples, each wray including I samples or Q samples from any one of said rays;

10 successively descrambling each wray of samples with the scrambling bit sequence;

successively correlating the descrambled samples in the selected wrays with a set of known code sequences and generating correlation values;

15 successively combining said correlation values to generate combined values; and

successively comparing the combined values with each other to detect each transmitted scrambled code symbol, said detected scrambled code symbols corresponding to said stream of data symbols.

20 45. The method according to claim 44 wherein said step of successively selecting includes the step of successively selecting said samples from two different wrays, a first wray including I samples from one of said rays and a second wray including Q samples from one of said rays.

30 46. The method according to claim 44 further including the steps of: successively removing a selected one of said code symbols corresponding to the detected one of said code symbols from the composite signal to generate a residual composite signal; and

successively reconstructing the original composite signal samples less the selected code

- 47 -

symbol from the residual composite signal and transmitting the samples to the selecting means.

47. The method according to claim 46 wherein said step of reconstructing further includes:

5 inverse correlating the residual composite signal; and

rescrambling the residual composite signal to reconstruct the original composite signal without the code symbol corresponding to the detected code symbol
10 using the scrambling bit sequence.

48. The method according to claim 47 wherein said step of correlating includes computing a fast Walsh transform to correlate the samples to known Walsh-Hadamard sequences and said step of inverse
15 correlating includes computing an inverse fast Walsh transform to reconstruct samples of the residual composite signal.

49. The method according to claim 46 wherein said step of comparing determines which combined
20 value is the largest, and said step of removing removes the code symbol corresponding to the largest correlation value from the composite signal to form the residual composite signal.

50. A method according to claim 44 wherein said
25 set of known code sequences are code words from an orthogonal block code.

51. A method according to claim 44 wherein said set of known code sequences are code words from a bi-orthogonal block code.

- 48 -

52. The method according to claim 44 wherein the step of correlating includes computing a fast Walsh transform to correlate the samples to known Walsh-Hadamard sequences.

5 53. In a code division multiple access system, a method for communicating data symbols to a receiver, wherein a transmitter maps a stream of data symbols into a stream of code symbols and further combines each code symbol with one scrambling bit sequence to form a stream of respective transmitted
10 scrambled code symbols, the method comprising the steps of:

receiving a composite signal of overlapping modulated carrier signals including at least two rays
15 and demodulating the composite signal to recover the transmitted scrambled code symbols in each ray, producing in-phase (I) and quadrature (Q) components for each ray;

sampling the I and Q components to produce at
20 least one I sample and at least one Q sample for each transmitted scrambled code symbol;

successively selecting at least two ways of said samples, each way including I samples or Q samples from any one of said rays;

25 successively descrambling each way of samples with the scrambling bit sequence;

successively combining said descrambled ways of samples to generate groups of combined samples;

30 successively correlating said groups of combined samples with a set of known code sequences and generating a plurality of correlation values, one for each sequence; and

successively comparing the correlation values with each other to detect each transmitted scrambled

- 49 -

code symbol, said detected scrambled code symbols corresponding to said stream of data symbols.

54. The method according to claim 53 wherein said step of selecting includes the step of selecting
5 said samples from two different ways, a first way including I samples from one of said rays and a second way including Q samples from one of said rays.

55. The method according to claim 53 wherein
10 the step of correlating includes computing a fast Walsh transform to correlate the samples to known Walsh-Hadamard sequences.

56. The method according to claim 53 wherein said set of known code sequences are code words in an
15 orthogonal block code.

57. The method according to claim 53 wherein said set of known code sequences are code words in a bi-orthogonal block code.

58. In a spread spectrum communications system,
20 a method for receiving spread spectrum information signals and determining received data sequences, said method comprising:

receiving a composite signal of overlapping,
transmitted signals;

25 sampling said composite signal;

selecting at least two ways of composite signal samples; and

combining said composite signal samples in each
of said selected ways to recover the transmitted
30 data signal.

AMENDED CLAIMS

[received by the International Bureau on 31 August 1993 (31.08.93); original claims 1-3,5-11,16,17,25,26,30,31,33-39, 44,45,53,54 and 58 amended; other claims unchanged (16 pages)]

CLAIMS:

1. In a spread spectrum communications system wherein a transmitter transmits a data signal to a receiver, said receiver comprising:

means for receiving at least two rays of the data signal, wherein the receiving means produces in-phase (I) and quadrature (Q) components for each ray;

means for sampling said I and Q components to produce at least one I sample and at least one Q sample for each ray;

means for selecting at least two wrays of said samples, each wray including I samples or Q samples from any one of said rays; and

means for combining said samples in each of said selected wrays to recover the transmitted data signal.

2. In a code division multiple access system for communicating a sequence of data symbols to a receiver, wherein a transmitter combines each data symbol with a known code sequence to form a respective transmitted symbol, said receiver comprising:

means for receiving a composite signal of overlapping modulated carrier signals including at least two rays and for demodulating the composite signal to recover the transmitted symbols in each ray, the receiving and demodulating means producing in-phase (I) and quadrature (Q) components for each ray;

means for sampling said I and Q components to produce at least one I sample and at least one Q sample for each transmitted symbol;

means for selecting at least two ways of said samples, each way including I samples or Q samples from any one of said rays;

means for correlating said samples in each of said selected ways to a known code sequence and generating correlation values;

means for combining said correlation values to generate a combined value; and

means for comparing said combined value with a threshold to determine each data symbol corresponding to each transmitted symbol.

3. The system according to claim 2 wherein said selecting means selects said samples from two different ways, a first way including I samples from one of said rays and a second way including Q samples from one of said rays.

4. The system according to claim 2 wherein the combining means includes:

means for multiplying each correlation value by a corresponding weight to produce a plurality of weighted values; and

means for summing the weighted values to generate said combined value.

5. The system according to claim 2 wherein the correlation means includes a single complex correlator for correlating each selected way with said known code sequence.

6. The system according to claim 2 wherein the correlation means includes a single scalar correlator for correlating each selected way with said known code sequence.

7. The system according to claim 2 wherein the correlation means includes a plurality of complex correlators for correlating each selected wray with said known code sequence.

8. The system according to claim 2 wherein the correlation means includes a plurality of scalar correlators for correlating each selected wray with said known code sequence.

9. In a code division multiple access system for communicating a sequence of data symbols to a receiver, wherein a transmitter combines each data symbol with a known code sequence to form a respective transmitted symbol, said receiver comprising:

means for receiving a composite signal of overlapping modulated carrier signals including at least two rays and for demodulating the composite signal to recover the transmitted symbols in each ray, the receiving and demodulating means producing in-phase (I) and quadrature (Q) components for each ray;

means for sampling said I and Q components to produce at least one I sample and at least one Q sample for each transmitted symbol;

means for selecting at least two wrays of said samples, each wray including I samples or Q samples from any one of said rays;

means for combining said samples in each of said selected wrays to generate groups of combined samples;

means for correlating said groups of combined samples with a known code sequence and generating a correlation value; and

means for comparing said correlation value with a threshold to determine each data symbol corresponding to each transmitted symbol.

10. The system according to claim 9 wherein said selecting means selects said samples from two different wrays, a first wray including I samples from one of said rays and a second wray including Q samples from one of said rays.

11. The system according to claim 9 wherein the combining means includes:

means for multiplying each sample by a corresponding weight to produce a plurality of weighted values; and

means for summing the weighted values [from different groups] to generate said groups of combined samples.

12. The system according to claim 11 wherein the multiplying means includes a single complex sample-by-sample multiplier for multiplying each sample by said corresponding weight.

13. The system according to claim 11 wherein the multiplying means includes a single scalar sample-by-sample multiplier for multiplying each sample by said corresponding weight.

14. The system according to claim 11 wherein the multiplying means includes a plurality of complex sample-by-sample multipliers for multiplying each sample by said corresponding weight.

15. The system according to claim 11 wherein the multiplying means includes a plurality of scalar

-54-

sample-by-sample multipliers for multiplying each sample by said corresponding weight.

16. In a code division multiple access system for communicating data symbols to a receiver, wherein a transmitter maps a stream of data symbols into a stream of code symbols and further combines each code symbol with one scrambling bit sequence to form a stream of respective transmitted scrambled code symbols, the receiver comprising:

means for receiving a composite signal of overlapping modulated carrier signals including at least two rays and for demodulating the composite signal to recover the transmitted scrambled code symbols in each ray, the receiving and demodulating means producing in-phase (I) and quadrature (Q) components for each ray;

means for sampling the I and Q components to produce at least one I sample and at least one Q sample for each transmitted scrambled code symbol;

means for successively selecting at least two ways of said samples, each way including I samples or Q samples from any one of said rays;

means for successively descrambling each way of samples with the scrambling bit sequence;

means for successively correlating the descrambled samples in the selected ways with a set of known code sequences and generating correlation values;

means for successively combining said correlation values to generate combined values; and

means for successively comparing the combined values with each other to detect each transmitted scrambled code symbol, said detected scrambled code symbols corresponding to said stream of data symbols.

17. The system according to claim 16 wherein said selecting means successively selects said samples from two different wrays, a first wray including I samples from one of said rays and a second wray including Q samples from one of said rays.

18. The system according to claim 16 further including:

means for successively removing a selected one of said code symbols corresponding to the detected one of said code symbols from the composite signal to generate a residual composite signal; and

means for successively reconstructing the original composite signal samples less the selected code symbol from the residual composite signal and transmitting the samples to the selecting means.

19. The system according to claim 18 wherein said reconstructing means further includes:

means for inverse correlating the residual composite signal; and

means for rescrumbling the residual composite signal to reconstruct the original composite signal without the code symbol corresponding to the detected code symbol using said scrambling bit sequence.

20. The system according to claim 19 wherein said correlating means includes means for computing a fast Walsh transform to correlate the samples to known Walsh-Hadamard sequences and said inverse correlating means includes means for computing an inverse fast Walsh transform to reconstruct samples of the residual composite signal.

21. The system according to claim 18 wherein said comparing means determines which combined value is the largest, and said removing means removes the code symbol, corresponding to the largest correlation value, from the composite signal to form the residual composite signal.

22. The system according to claim 16 wherein the correlation means includes means for computing a fast Walsh transform to correlate the samples to known Walsh-Hadamard sequences.

23. A system according to claim 16 wherein said set of known code sequences are code words from an orthogonal block code.

24. A system according to claim 16 wherein said set of known code sequences are code words from a bi-orthogonal block code.

25. In a code division multiple access system for communicating data symbols to a receiver, wherein a transmitter maps a stream of data symbols into a stream of code symbols and further combines each code symbol with one scrambling bit sequence to form a stream of respective transmitted scrambled code symbols, the receiver comprising:

means for receiving a composite signal of overlapping modulated carrier signals including at least two rays and for demodulating the composite signal to recover the transmitted scrambled code symbols in each ray, the receiving and demodulating means producing in-phase (I) and quadrature (Q) components for each ray;

means for sampling the I and Q components to produce at least one I sample and at least one Q sample for each transmitted scrambled code symbol;

means for successively selecting at least two wrays of said samples, each wray including I samples or Q samples from any one of said rays;

means for successively descrambling each wray of samples with the scrambling bit sequence;

means for successively combining said descrambled wrays of samples to generate groups of combined samples; and

means for successively correlating said groups of combined samples with a set of known code sequences and generating a plurality of correlation values, one for each sequence; and

means for successively comparing the correlation values with each other to detect each transmitted scrambled code symbol, said detected scrambled code symbols corresponding to said stream of data symbols.

26. The system according to claim 25 wherein said selecting means selects said samples from two different wrays, a first wray including I samples from one of said rays and a second wray including Q samples from one of said rays.

27. The system according to claim 25 wherein the correlation means includes means for computing a fast Walsh transform to correlate the samples to known Walsh-Hadamard sequences.

28. A system according to claim 25 wherein said set of known code sequences are code words in an orthogonal block code.

29. A system according to claim 25 wherein said set of known code sequences are code words in a bi-orthogonal block code.

30. In a code division multiple access system, a method for communicating a sequence of data symbols to a receiver, wherein a transmitter combines each data symbol with a known code sequence to form a respective transmitted symbol, said method comprising the steps of:

receiving a composite signal of overlapping modulated carrier signals including at least two rays;

demodulating the composite signal to recover the transmitted symbols in each ray, producing in-phase (I) and quadrature (Q) components for each ray;

sampling said I and Q components to produce at least one I sample and at least one Q sample for each transmitted symbol;

selecting at least two wrays of said samples, each wray including I samples or Q samples from any one of said rays;

correlating said samples in each of said selected wrays to a known code sequence and generating correlation values;

combining said correlation values to generate a combined value; and

comparing said combined value with a threshold to determine each data symbol corresponding to each transmitted symbol.

31. The method according to claim 30 wherein said step of selecting includes the step of selecting said samples from two different wrays, a first wray including I samples from one of said rays and a

second wray including Q samples from one of said rays.

32. The method according to claim 30 wherein said step of combining further includes the steps of:
multiplying each correlation value by a corresponding weight to produce a plurality of weighted values; and
summing the weighted values to generate said combined value.

33. The method according to claim 30 wherein the step of correlating includes correlating each selected wray with said known code sequence using a single complex correlator.

34. The method according to claim 30 wherein the step of correlating includes correlating each selected wray with said known code sequence using a single scalar correlator.

35. The method according to claim 30 wherein the step of correlating includes correlating each selected wray with said known code sequence using a plurality of complex correlators.

36. The method according to claim 30 wherein the step of correlating includes correlating each selected wray with said known code sequence using a plurality of scalar correlators.

37. In a code division multiple access system, a method for communicating a sequence of data symbols to a receiver, wherein a transmitter combines each data symbol with a known code sequence to form a

-60-

respective transmitted symbol, said method comprising the steps of:

receiving a composite signal of overlapping modulated carrier signals including at least two rays;

demodulating the composite signal to recover the transmitted symbols in each ray, producing in-phase (I) and quadrature (Q) components for each ray;

sampling said I and Q components to produce at least one I sample and at least one Q sample for each transmitted symbol;

selecting at least two wrays of said samples, each wray including I samples or Q samples from any one of said rays;

combining said wrays of samples to generate groups of combined samples;

correlating said groups of combined samples with a known code sequence and generating a correlation value; and

comparing said correlation value with a threshold to determine each data symbol corresponding to each transmitted symbol.

38. The method according to claim 37 wherein said step of selecting includes the step of selecting said samples from two different wrays, a first wray including I samples from one of said rays and a second wray including Q samples from one of said rays.

39. The method according to claim 37 wherein said step of combining further includes the steps of:

multiplying each sample by a corresponding weight to produce a plurality of weighted values; and

summing the weighted values to generate said groups of combined samples.

40. The method according to claim 39 wherein the step of multiplying includes multiplying each sample by said corresponding weight using a single complex sample-by-sample multiplier.

41. The method according to claim 39 wherein the step of multiplying includes multiplying each sample by said corresponding weight using a single scalar sample-by-sample multiplier.

42. The method according to claim 39 wherein the step of multiplying includes multiplying each sample by said corresponding weight using a plurality of complex sample-by-sample multipliers.

43. The method according to claim 39 wherein the step of multiplying includes multiplying each sample by said corresponding weight using a plurality of scalar sample-by-sample multipliers.

44. In a code division multiple access system, a method for communicating data symbols to a receiver, wherein a transmitter maps a stream of data symbols into a stream of code symbols and further combines each code symbol with one scrambling bit sequence to form a stream of respective transmitted scrambled code symbols, the method comprising the steps of:

receiving a composite signal of overlapping modulated carrier signals including at least two rays and demodulating the composite signal to recover the transmitted scrambled code symbols in each ray,

-62-

producing in-phase (I) and quadrature (Q) components for each ray;

sampling the I and Q components to produce at least one I sample and at least one Q sample for each transmitted scrambled code symbol;

successively selecting at least two wrays of said samples, each wray including I samples or Q samples from any one of said rays;

successively descrambling each wray of samples with the scrambling bit sequence;

successively correlating the descrambled samples in the selected wrays with a set of known code sequences and generating correlation values;

successively combining said correlation values to generate combined values; and

successively comparing the combined values with each other to detect each transmitted scrambled code symbol, said detected scrambled code symbols corresponding to said stream of data symbols.

45. The method according to claim 44 wherein said step of successively selecting includes the step of successively selecting said samples from two different wrays, a first wray including I samples from one of said rays and a second wray including Q samples from one of said rays.

46. The method according to claim 44 further including the steps of:

successively removing a selected one of said code symbols corresponding to the detected one of said code symbols from the composite signal to generate a residual composite signal; and

successively reconstructing the original composite signal samples less the selected code

symbol from the residual composite signal and transmitting the samples to the selecting means.

47. The method according to claim 46 wherein said step of reconstructing further includes:

inverse correlating the residual composite signal; and

rescrambling the residual composite signal to reconstruct the original composite signal without the code symbol corresponding to the detected code symbol using the scrambling bit sequence.

48. The method according to claim 47 wherein said step of correlating includes computing a fast Walsh transform to correlate the samples to known Walsh-Hadamard sequences and said step of inverse correlating includes computing an inverse fast Walsh transform to reconstruct samples of the residual composite signal.

49. The method according to claim 46 wherein said step of comparing determines which combined value is the largest, and said step of removing removes the code symbol corresponding to the largest correlation value from the composite signal to form the residual composite signal.

50. A method according to claim 44 wherein said set of known code sequences are code words from an orthogonal block code.

51. A method according to claim 44 wherein said set of known code sequences are code words from a bi-orthogonal block code.

-64-

52. The method according to claim 44 wherein the step of correlating includes computing a fast Walsh transform to correlate the samples to known Walsh-Hadamard sequences.

53. In a code division multiple access system, a method for communicating data symbols to a receiver, wherein a transmitter maps a stream of data symbols into a stream of code symbols and further combines each code symbol with one scrambling bit sequence to form a stream of respective transmitted scrambled code symbols, the method comprising the steps of:

receiving a composite signal of overlapping modulated carrier signals including at least two rays and demodulating the composite signal to recover the transmitted scrambled code symbols in each ray, producing in-phase (I) and quadrature (Q) components for each ray;

sampling the I and Q components to produce at least one I sample and at least one Q sample for each transmitted scrambled code symbol;

successively selecting at least two wrays of said samples, each wray including I samples or Q samples from any one of said rays;

successively descrambling each wray of samples with the scrambling bit sequence;

successively combining said descrambled wrays of samples to generate groups of combined samples;

successively correlating said groups of combined samples with a set of known code sequences and generating a plurality of correlation values, one for each sequence; and

successively comparing the correlation values with each other to detect each transmitted scrambled

code symbol, said detected scrambled code symbols corresponding to said stream of data symbols.

54. The method according to claim 53 wherein said step of selecting includes the step of selecting said samples from two different wrays, a first wray including I samples from one of said rays and a second wray including Q samples from one of said rays.

55. The method according to claim 53 wherein the step of correlating includes computing a fast Walsh transform to correlate the samples to known Walsh-Hadamard sequences.

56. The method according to claim 53 wherein said set of known code sequences are code words in an orthogonal block code.

57. The method according to claim 53 wherein said set of known code sequences are code words in a bi-orthogonal block code.

58. In a spread spectrum communications system, a method for receiving spread spectrum information signals and determining received data sequences, said method comprising:

- receiving a composite signal of overlapping, transmitted signals;
- sampling said composite signal;
- selecting at least two wrays of composite signal samples; and
- combining said composite signal samples in each of said selected wrays to recover the transmitted data signal.

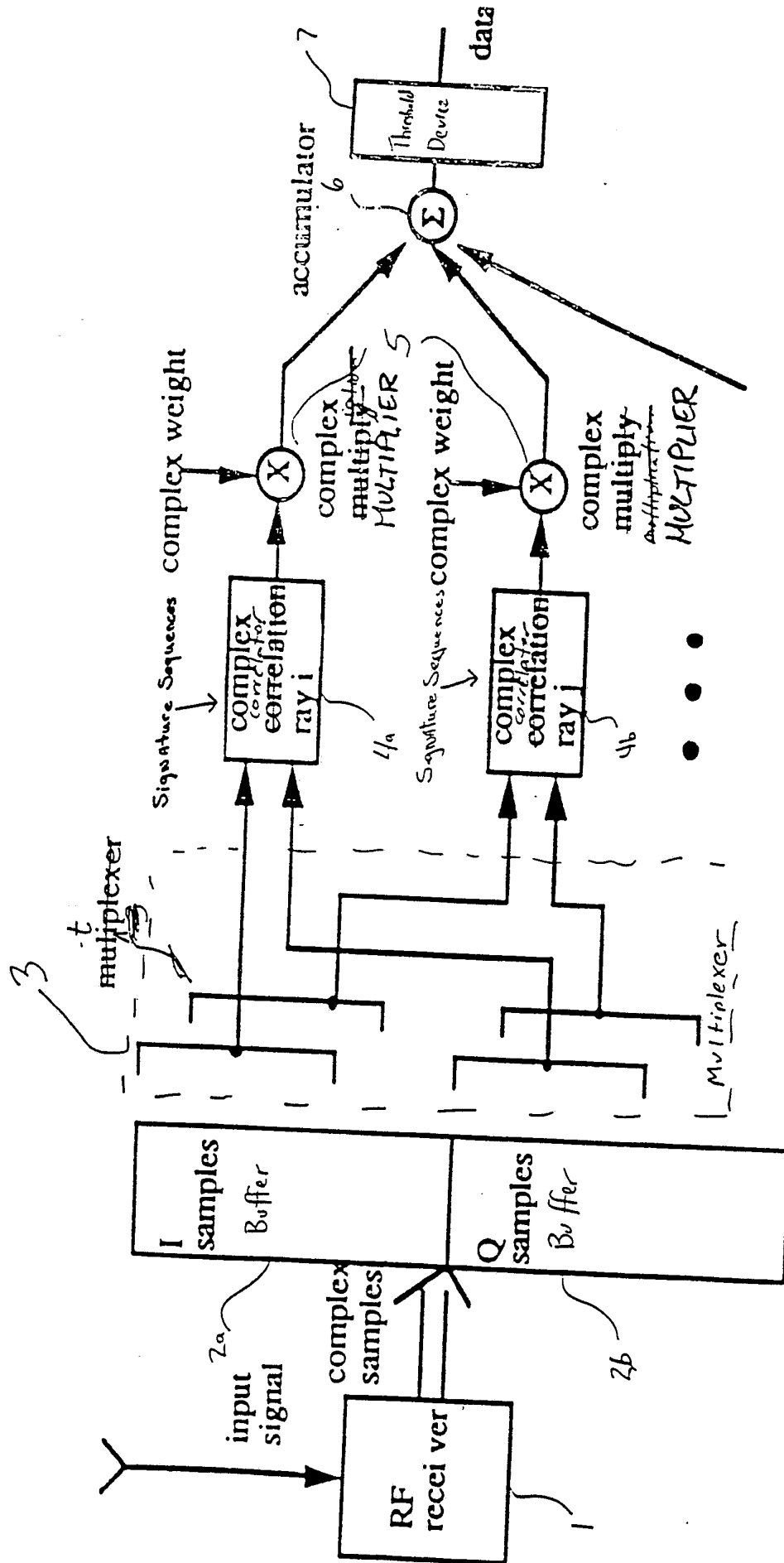

Fig. 1 PRIOR ART

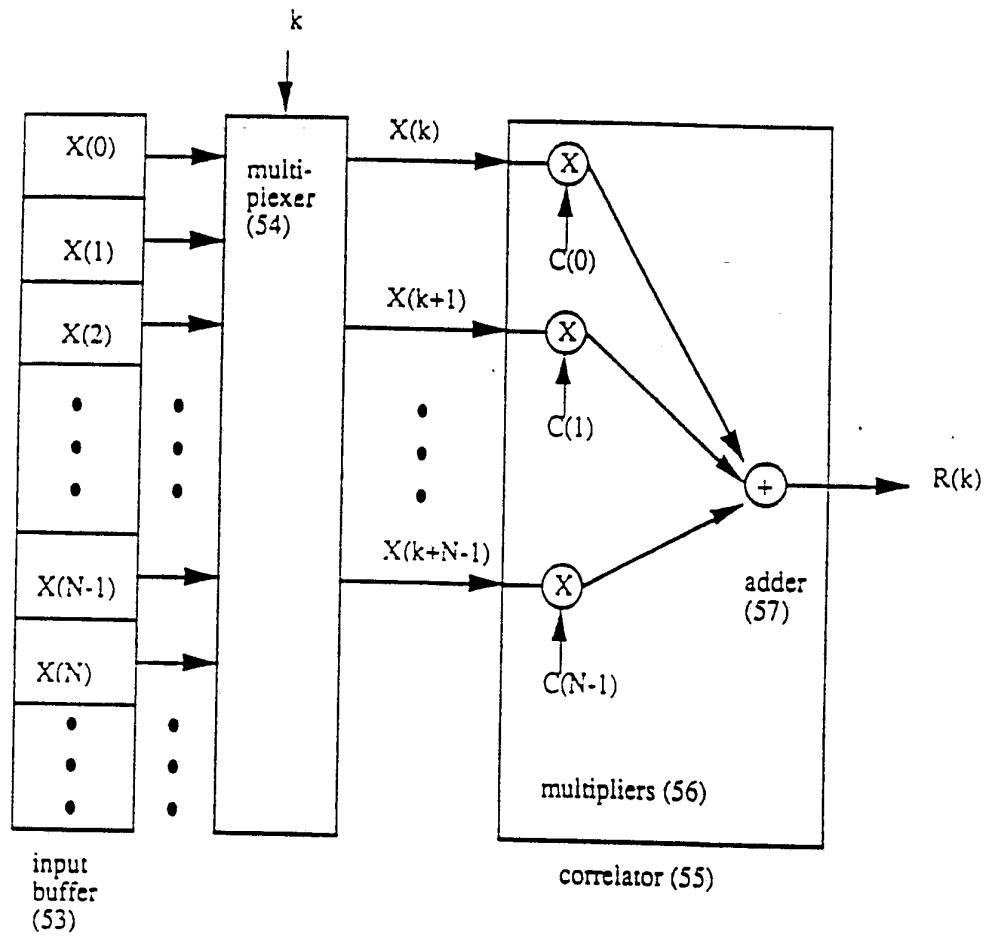

Fig. 2

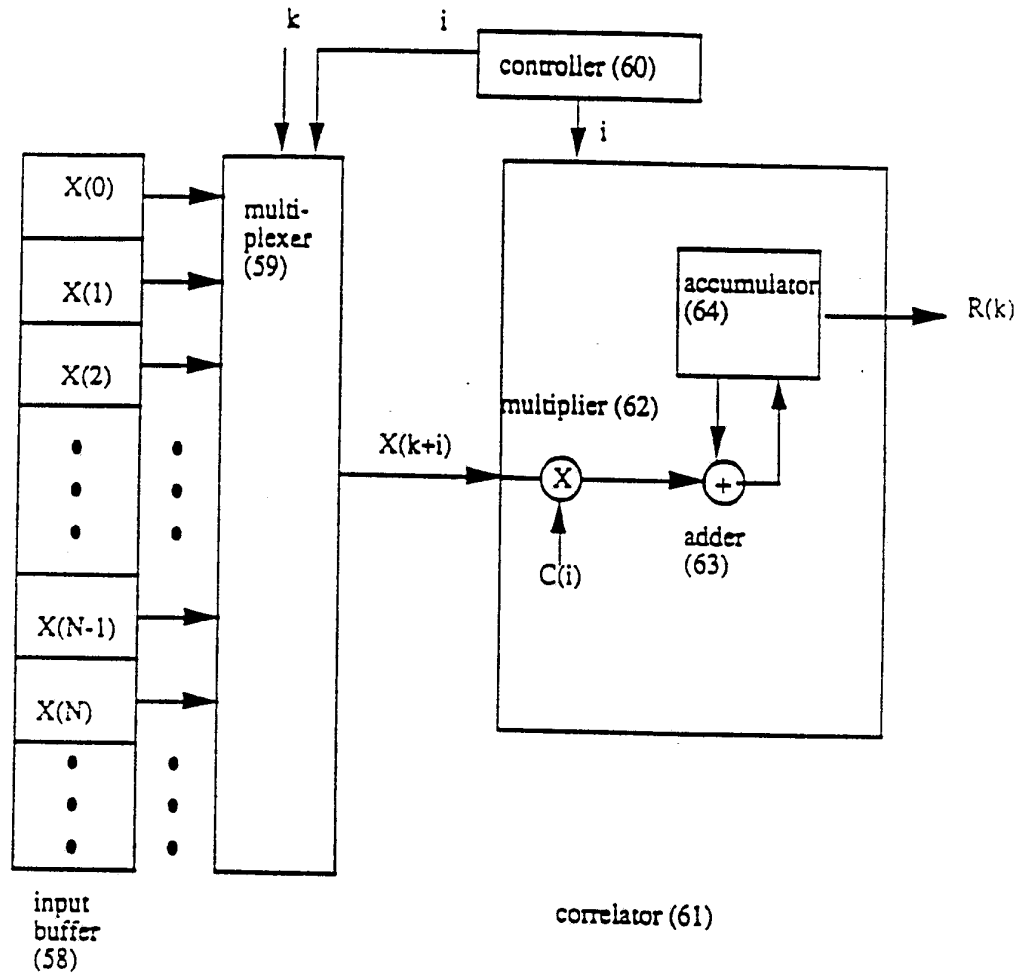

Fig. 3

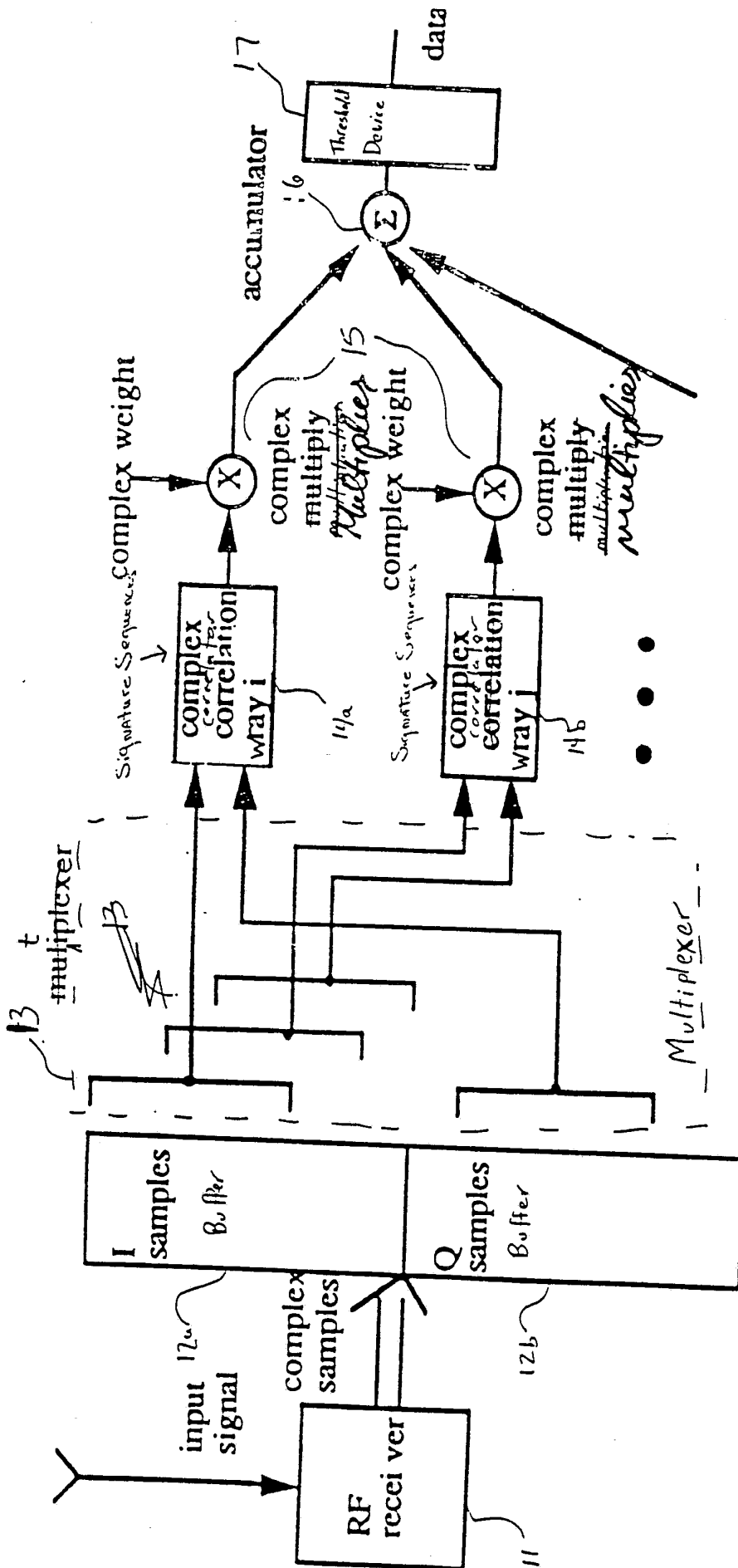

Fig. 4

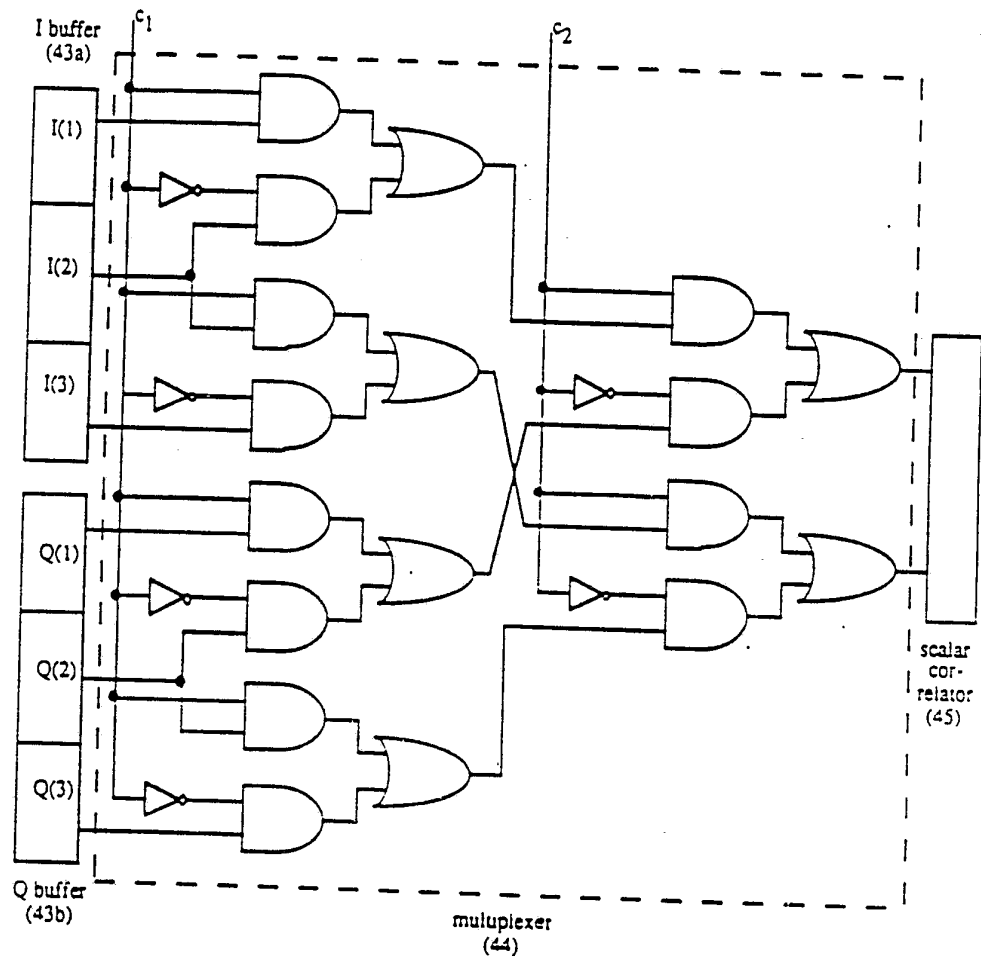

Fig. 5

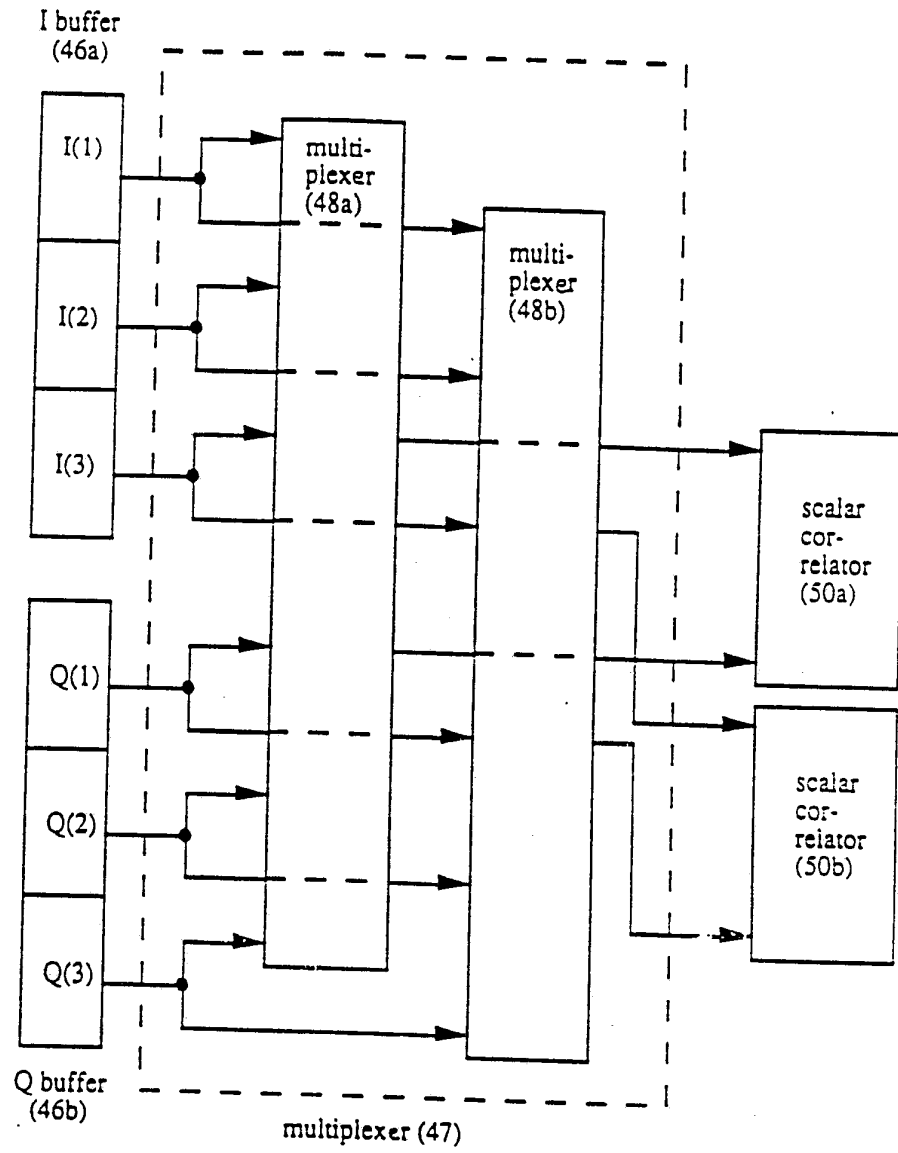

Fig. 6

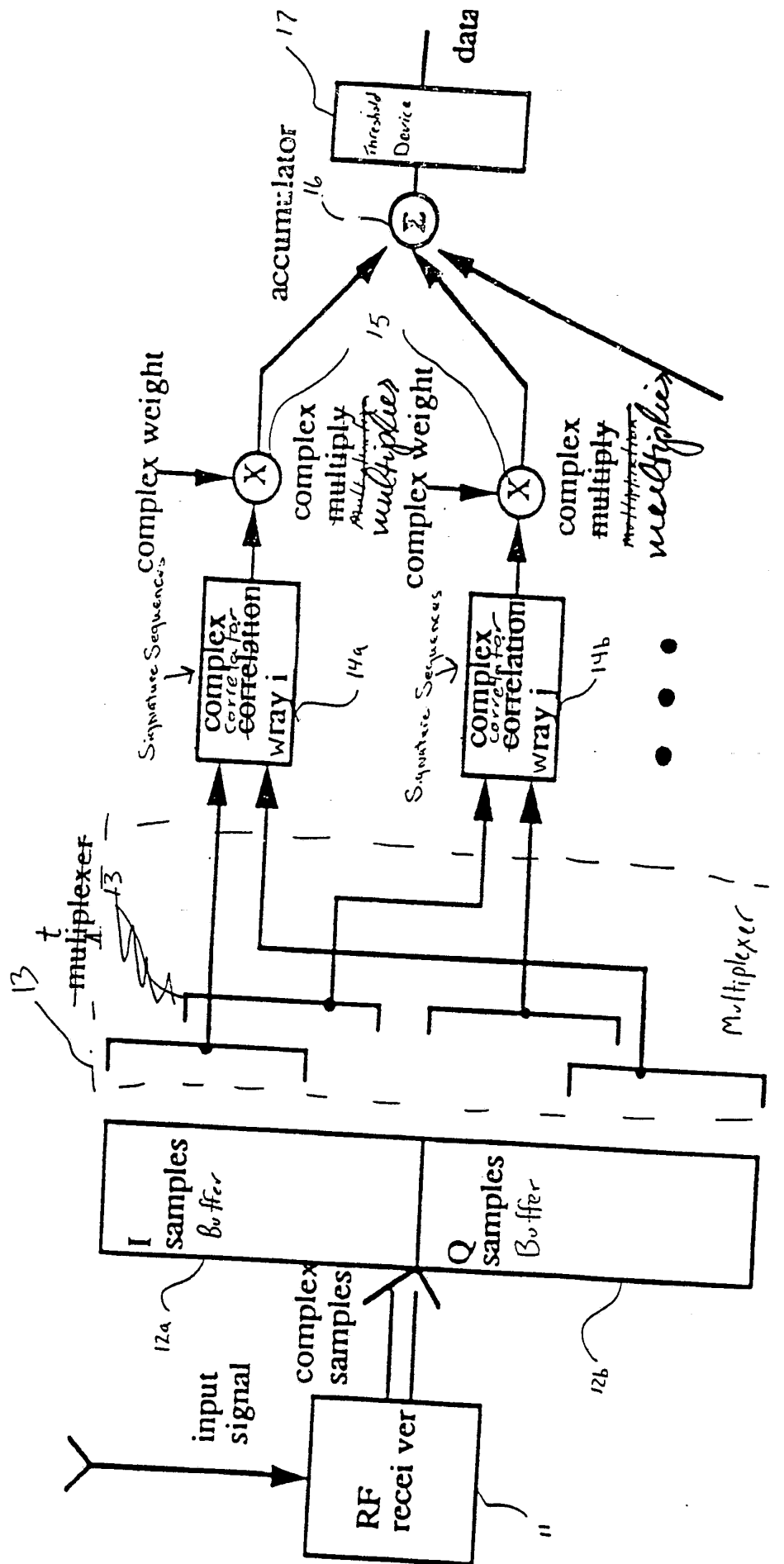

Fig. 7

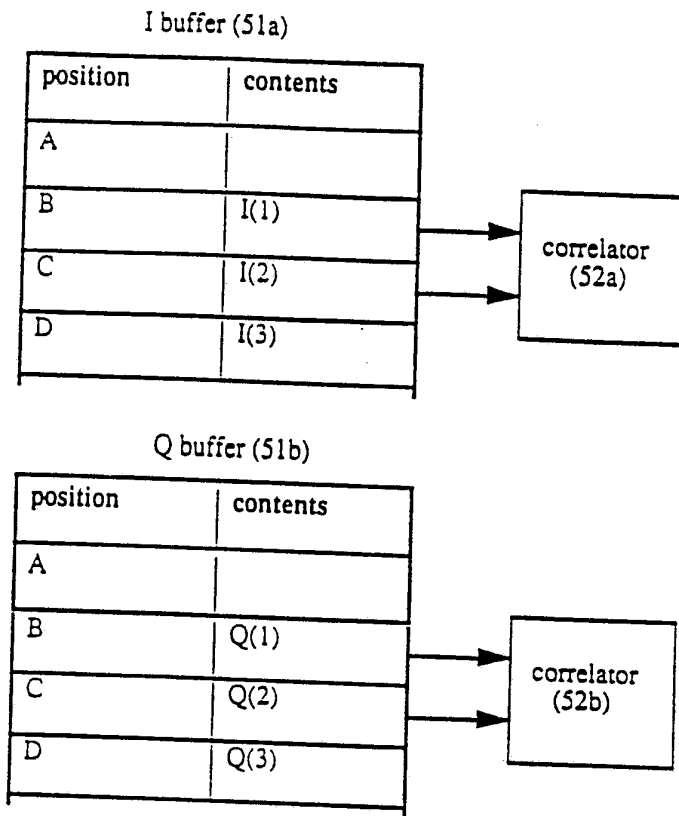

Fig. 8

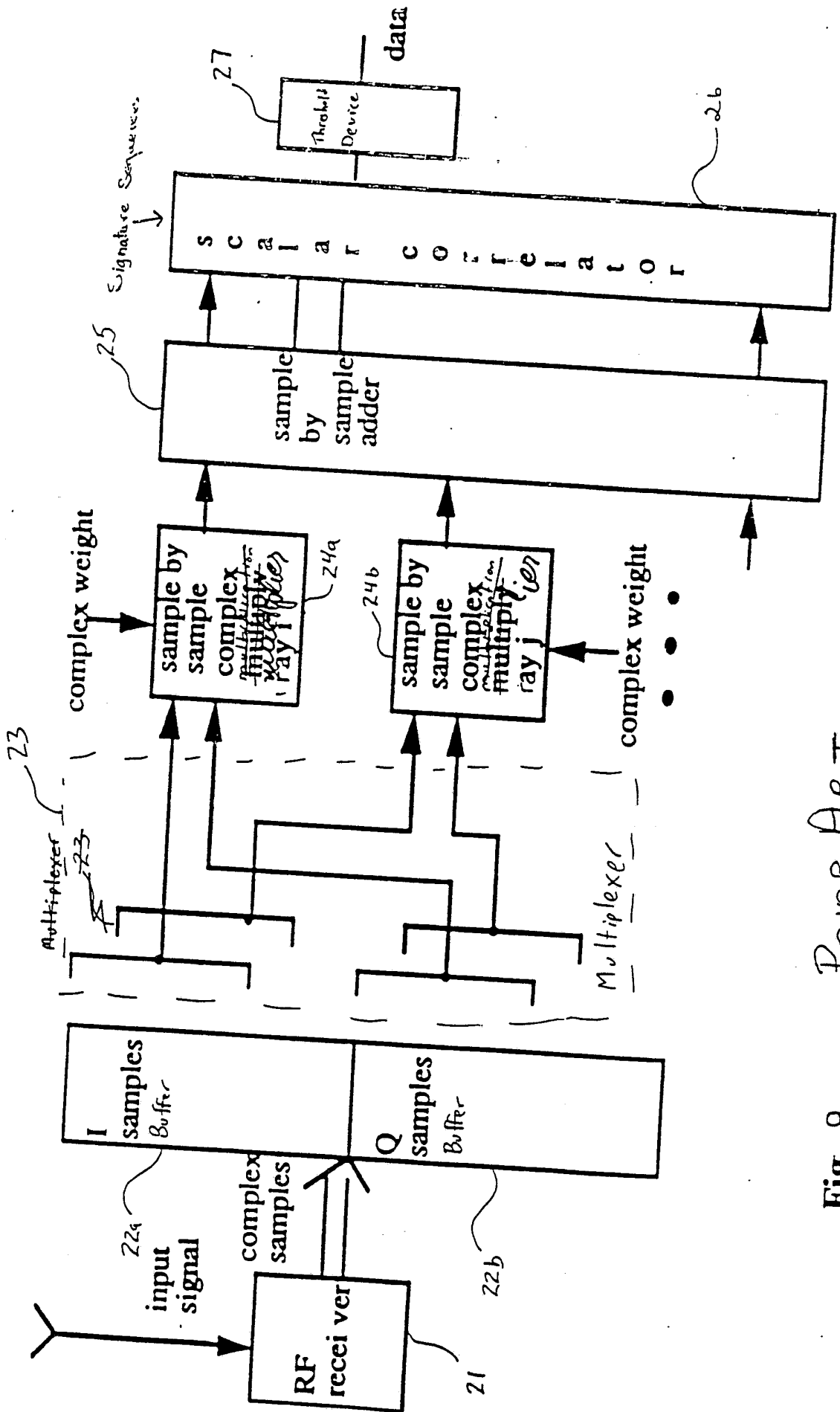

Fig. 9 PRIOR ART

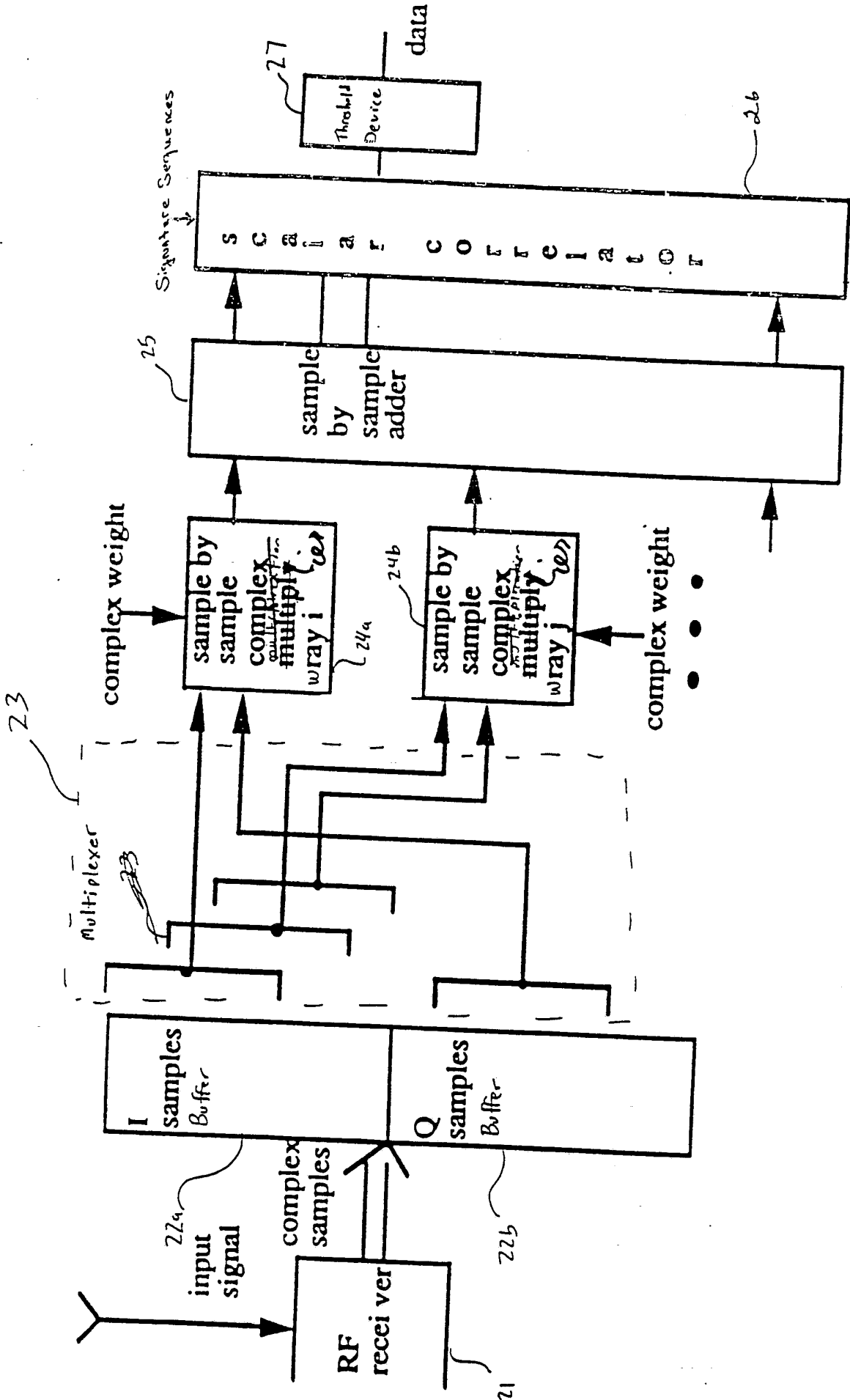

Fig. 10

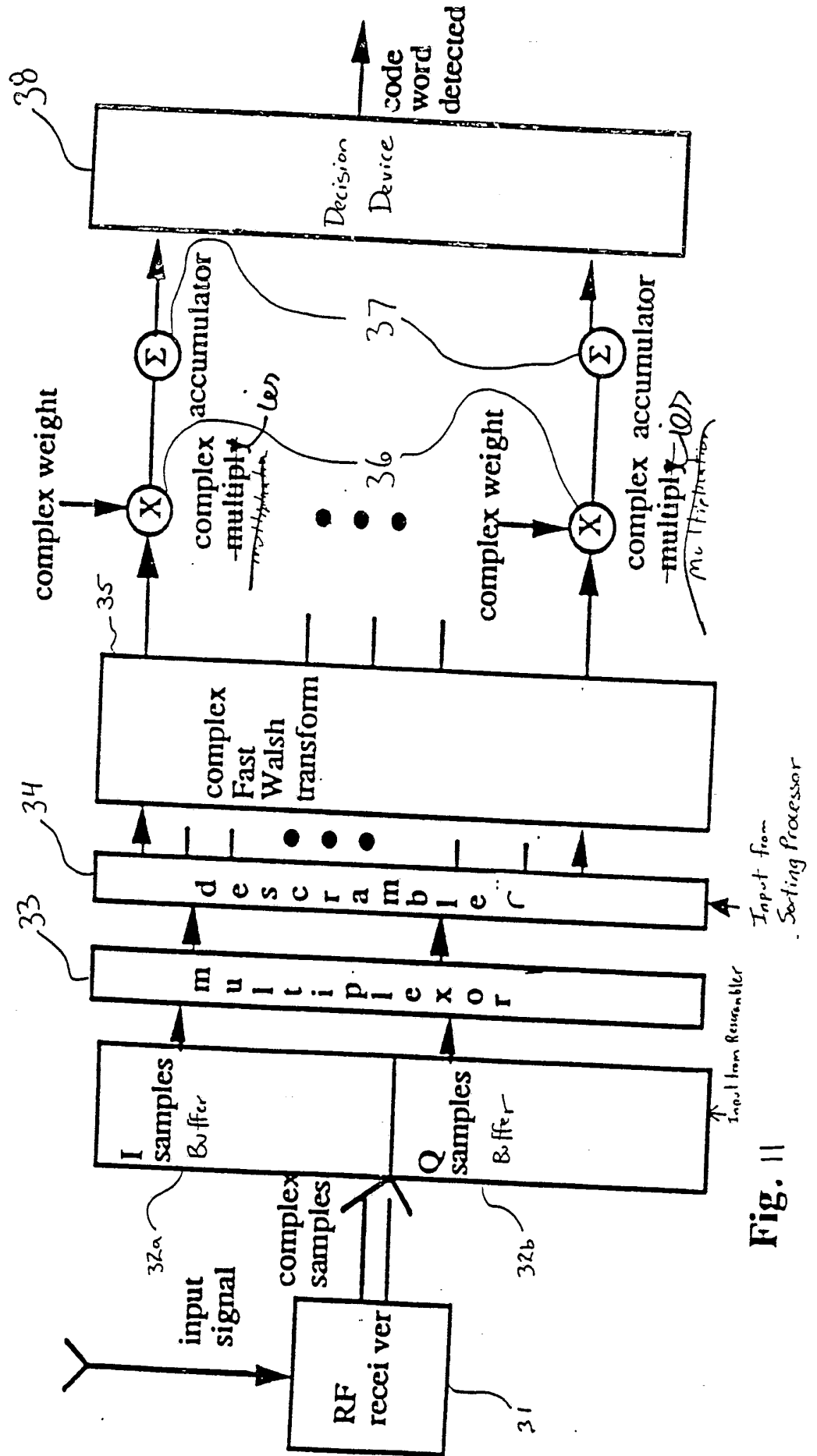

Fig. 11

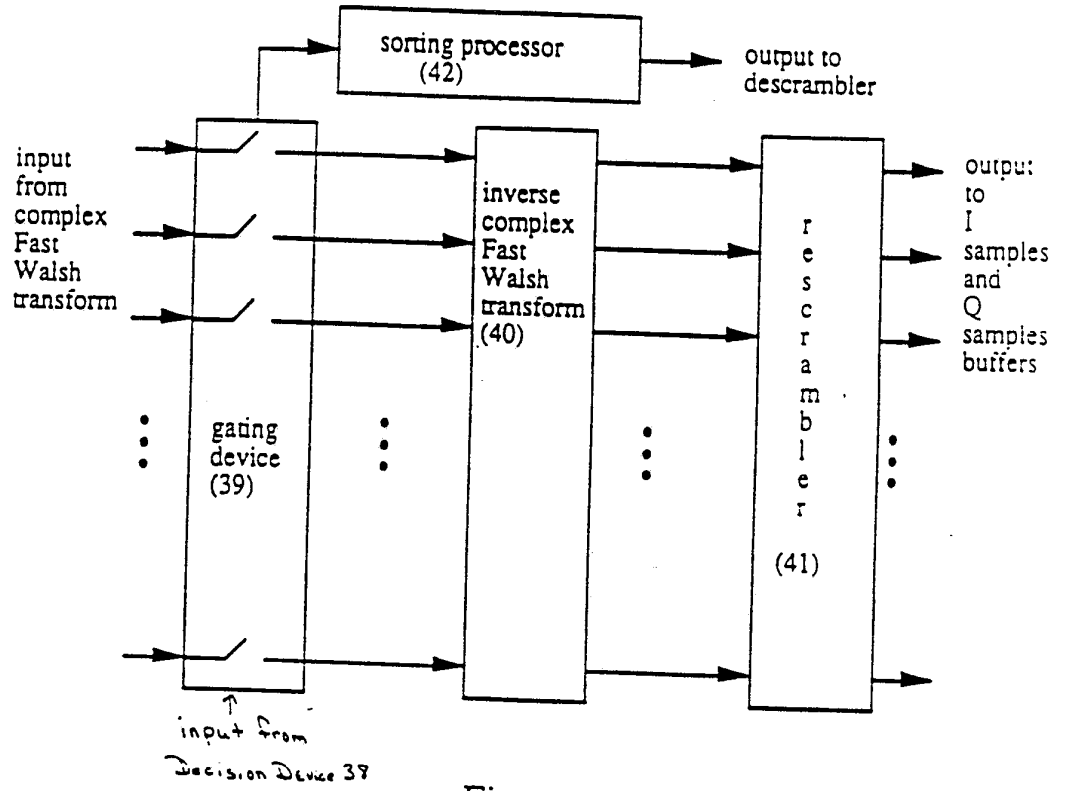

Fig. 12

INTERNATIONAL SEARCH REPORT

PCT/US93/02840

A. CLASSIFICATION OF SUBJECT MATTER		
IPC(5) :H04L 27/30 US CL :375/1 According to International Patent Classification (IPC) or to both national classification and IPC		
B. FIELDS SEARCHED		
Minimum documentation searched (classification system followed by classification symbols) U.S. : 375/1 375/1; 380/34		
Documentation searched other than minimum documentation to the extent that such documents are included in the fields searched		
Electronic data base consulted during the international search (name of data base and, where practicable, search terms used)		
C. DOCUMENTS CONSIDERED TO BE RELEVANT		
Category*	Citation of document, with indication, where appropriate, of the relevant passages	Relevant to claim No.
Y	US,A, 2,982,853 (Price et al.) 02 May 1961 See Fig. 2.	58
A	US,A, 4,653,069 (Roeder) 24 March 1987	1-58
<input type="checkbox"/> Further documents are listed in the continuation of Box C. <input type="checkbox"/> See patent family annex.		
* "A"	Special categories of cited documents: document defining the general state of the art which is not considered to be part of particular relevance	"T" later document published after the international filing date or priority date and not in conflict with the application but cited to understand the principle or theory underlying the invention
"E"	earlier document published on or after the international filing date	"X" document of particular relevance; the claimed invention cannot be considered novel or cannot be considered to involve an inventive step when the document is taken alone
"L"	document which may throw doubts on priority claim(s) or which is cited to establish the publication date of another citation or other special reason (as specified)	"Y" document of particular relevance; the claimed invention cannot be considered to involve an inventive step when the document is combined with one or more other such documents, such combination being obvious to a person skilled in the art
"O"	document referring to an oral disclosure, use, exhibition or other means	"&" document member of the same patent family
"P"	document published prior to the international filing date but later than the priority date claimed	
Date of the actual completion of the international search 05 MAY 1993		Date of mailing of the international search report 07 JUL 1993
Name and mailing address of the ISA/US Commissioner of Patents and Trademarks Box PCT Washington, D.C. 20231		Authorized officer <i>Nguyen Ngoc Ho</i> BERNARR EARL GREGORY NGUYEN NGOC HO
Facsimile No. NOT APPLICABLE		Telephone No. (703) 308-0479 INTERNATIONAL DIVISION