



(12) **EUROPEAN PATENT APPLICATION**

(43) Date of publication:
14.06.2006 Bulletin 2006/24

(51) Int Cl.:
E06B 9/58 (2006.01) **E06B 9/42 (2006.01)**
E06B 9/54 (2006.01)

(21) Application number: **05111434.6**

(22) Date of filing: **29.11.2005**

(84) Designated Contracting States:
**AT BE BG CH CY CZ DE DK EE ES FI FR GB GR
HU IE IS IT LI LT LU LV MC NL PL PT RO SE SI
SK TR**
Designated Extension States:
AL BA HR MK YU

(71) Applicant: **Corradi S.r.l.**
40128 Bologna (IT)

(72) Inventor: **Grazioso, Luca**
64020 Teramo, Frazione Sant'Atto (IT)

(30) Priority: **10.12.2004 IT BO20040762**

(74) Representative: **Modiano, Micaela Nadia et al**
Dr. Modiano & Associati S.p.A.
Via Meravigli 16
20123 Milano (IT)

(54) **Guiding assembly for roll-up awnings**

(57) A guiding assembly for roll-up awnings constituted by a covering sheet (2) which can be rolled up onto a roller which is accommodated rotatably within a respective upper containment box, the sheet (2) being associated with the roller by means of one of its upper ends, each one of the two lateral edges of the sheet being provided with a sort of flexible set of teeth (3), which is guided so that it can slide within a longitudinal recess (4) of a corresponding rail (5), further comprising two lateral supporting profiled elements (7), each of which forms a first half-shoulder (12) for the rail (5) and a first half-guide (10) for a transverse bar (11) associated with the lower end of the sheet (2), and comprises two panels (8), each of which forms a second half-shoulder (18), which is complementary to the first one, for the rail (5), and a second half-guide (19), which is complementary to the first one, for the bar (11), each one of the panels (8) being detachably engageable on a respective profiled element (7) by way of provided interlocking means.

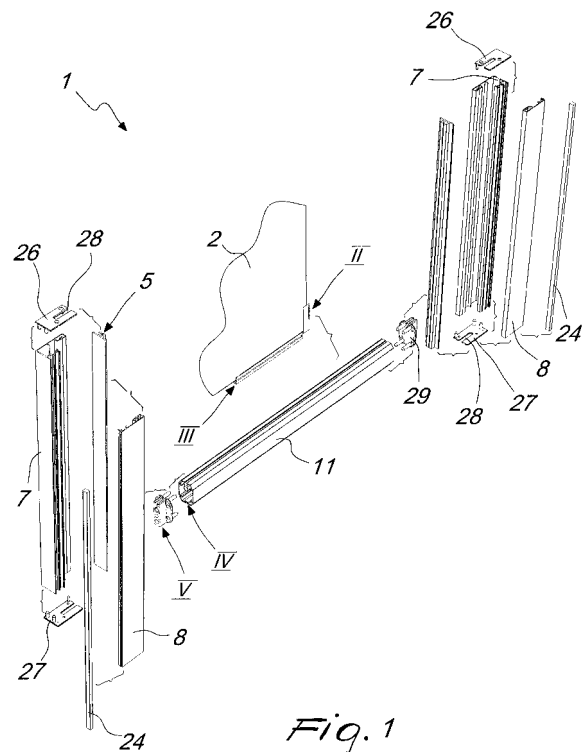

Fig. 1

Description

[0001] The present invention relates to a guiding assembly for roll-up awnings.

[0002] In order to cover the openings of buildings, such as doors, windows, skylights and the like, it is known to use awnings constituted by a covering sheet which can be rolled up onto a roller which is accommodated rotatably in a respective box arranged above the opening. The sheet is associated by means of its upper end with the roller and is connected by means of its lower end to a transverse bar for grip on the part of the user; each one of the two lateral edges of the sheet is provided with a sort of flexible set of teeth, which is guided slidingly within a longitudinal recess of a corresponding rail of a provided guiding assembly associated with the opening to be covered. Such guiding assembly comprises notoriously two vertical uprights, which have a substantially U-shaped transverse cross-section and are fixed so as to face each other on the open side of said U-shape. In a practical example of installation, the uprights are fixed to the inner sides of an opening by way of suitable screw means inserted in corresponding holes.

[0003] The rail is accommodated internally with respect to the arms of the U-shape, each of which comprises interlocking elements for detachable coupling to a respective strip (one for each arm); the strips have a conveniently contoured transverse cross-section, which forms an abutment for the rail and a sliding guide for the transverse bar; further, such strips can be removed in order to allow normal maintenance operations.

[0004] However, the installation of such assemblies is laborious also due to the difficulty of correctly positioning the screw means in the uprights, for locking them to a wall; moreover, after the strips have been separated and fitted on the uprights a few times, for example for ordinary maintenance operations, the corresponding interlocking elements wear rapidly and therefore the strips tend to detach spontaneously, causing the awning to malfunction.

[0005] The aim of the present invention is to solve the above-mentioned drawbacks, by providing a guiding assembly for roll-up awnings which allows quick and stable installation.

[0006] Within this aim, an object of the invention is to provide an assembly which, thanks to its particular constructive characteristics, is capable of giving the greatest assurances of reliability and safety in use.

[0007] Another object of the present invention is to provide an assembly which is simple, relatively easy to provide in practice, effective in operation, and also competitive from an economic standpoint.

[0008] This aim and these and other objects that will become better apparent hereinafter are achieved by a guiding assembly for roll-up awnings constituted by a covering sheet which can be rolled up onto a roller which is accommodated rotatably within a respective upper containment box, said sheet being associated with the

roller by means of one of its upper ends, each one of the two lateral edges of said sheet being provided with a sort of flexible set of teeth, which is guided so that it can slide within a longitudinal recess of a corresponding rail, characterized in that it comprises two lateral supporting profiled elements, each of which forms a first half-shoulder for said rail and a first half-guide for a transverse bar associated with the lower end of said sheet, and comprises two panels, each of which forms a second half-shoulder, which is complementary to the first one, for said rail, and a second half-guide, which is complementary to the first one, for said bar, each one of said panels being detachably engageable on a respective profiled element by way of provided interlocking means.

[0009] Further characteristics and advantages of the invention will become better apparent from the following detailed description of a preferred but not exclusive embodiment of a guiding assembly according to the invention, illustrated by way of non-limiting example in the accompanying drawings, wherein:

Figure 1 is an exploded perspective view of a guiding assembly according to the invention;

Figure 2 is an enlarged-scale perspective view of the detail II of Figure 1;

Figure 3 is an enlarged-scale perspective view of the detail III of Figure 1;

Figure 4 is an enlarged-scale perspective view of the detail IV of Figure 1;

Figure 5 is an enlarged-scale perspective view of the detail V of Figure 1;

Figure 6 is an exploded perspective view of a guiding assembly;

Figure 7 is a transverse sectional view of a guiding assembly in the assembled condition.

[0010] With reference to the figures, the reference numeral 1 generally designates a guiding assembly for roll-up awnings according to the invention.

[0011] The awnings are constituted by a covering sheet 2, which can be rolled up onto a roller which is accommodated so that it can rotate in a respective upper containment box (the roller and the box are not shown in the figures, since they are fully known); the sheet is associated, by means of one of its upper ends, with the roller, and each one of its two lateral edges is provided with a sort of flexible set of teeth 3, which is guided slidingly within a longitudinal recess 4 of a corresponding rail 5 of the guiding assembly 1. The rail 5 is provided with a flat base 6 and is crossed along its entire length by the longitudinal recess 4.

[0012] The guiding assembly 1 comprises two lateral supporting profiled elements 7, each of which has a substantially L-shaped transverse cross-section, and two panels 8, each of which has a substantially I-shaped transverse cross-section and can engage detachably a respective profiled element 7 by way of provided interlocking means.

[0013] Advantageously, such interlocking means comprise at least one wing 9 on each profiled element and at least one wing on each panel.

[0014] In particular, the long portion of the L-shape of each profiled element is provided with a substantially rectangular end region which cantilevers inward; such end region forms a first half-guide 10 for a transverse bar 11, which is associated with the lower end of the sheet 2, and further forms, toward the short side of the L-shape, a first half-shoulder 12 for the rail 5.

[0015] The short side of the L-shape comprises, starting from an end portion 13, a cantilevered portion 14 which is substantially perpendicular to said short side.

[0016] The cantilevered portion 14 is provided with a step 15 and with two wings 9, which are directed outward, for the interlocking of the corresponding panel 8.

[0017] Each one of the profiled elements 7 comprises, on the long side of the L-shape, a longitudinal ridge 16, which forms a first abutment for the base of the rail, and further comprises a second abutment, which is complementary to the first one and is formed by a flat end surface 17 of the cantilevered portion 14 of the short side of the L-shape.

[0018] Each panel 8 is provided with a respective end part which is substantially rectangular and cantilevered and is arranged, when the assembly is assembled, mirror-symmetrically with respect to the end region of the profiled element 7; such end part forms a second half-shoulder 18, which is complementary to the first half-shoulder on the profiled element 7, for the rail 5, and a second half-guide 19, which is complementary to the first one on the profiled element 7, for the bar 11.

[0019] On the other side, each panel 8 is provided with two wings 9, which are inclined complementarily for interlocking on the corresponding profiled element 7, and an end wall 20, which faces, in the coupled configuration, the step 15 of the profiled element 7.

[0020] Positively, such pairs of wings 9 on each profiled element 7 and on each panel 8 are inclined complementarily at a preset angle and have an enlarged end portion 21, which can engage a corresponding seat 22 formed between the base of each one of the wings 9 and the linear portion from which they extend.

[0021] Conveniently, the profiled element 7 and the panel 8, in the coupled configuration, form, between the end portion 13 and the cantilevered portion 14 of the short side of the L-shape and the end wall 20 of the panel, a receptacle 23 for the interlocking insertion of a closure element 24 of the guiding assembly 1.

[0022] Conveniently, the end portion 13 and the end wall 20 each have a longitudinal protrusion 25 for detachably retaining the closure element 24.

[0023] Conveniently, the closure element 24 is constituted by a rod made of a material such as rubber or also by a contoured rod made of metallic material, for example an aluminum extrusion.

[0024] The guiding assembly 1 further comprises an upper closure plug 26 and a lower closure plug 27, which

can be fixed onto each profiled element 7. Conveniently, each one of the plugs 26, 27 is affected by a slot 28, which is open on the inner side for the passage of the sheet 2 and constitutes an abutment for the bar 11, which is guided between the profiled elements 7 and the panels 8.

[0025] Advantageously, the bar 11 comprises laterally terminal guiding means 29 and is affected by a longitudinal slot 30, which is open upward and has a transverse profile which is shaped complementarily with respect to a rounded border 31, which is associated with the lower end of the sheet 2 which can be inserted in the slot 30.

[0026] Each one of the terminal guiding means 29 is affected by a slot 30a, which is open upward and corresponds to the slot 30 on the bar 11 and has an identical transverse profile; the slot 30a accommodates the border 31 of the sheet 2 up to the vicinity of the rail 5, conveniently stabilizing the lateral edge of the sheet, provided with the set of teeth 3, during its sliding in the recess 4 of the rail 5.

[0027] Each profiled element 7 can be fixed conveniently to a wall or to the internal sides of an opening by way of screw means 32, which can be inserted in holes provided, according to the requirements, on the short side or on the long side of the L-shape. In order to fix detachably the panel 8 onto the profiled element 7, the wings 9 of the panel 8 are arranged at the wings of the profiled element 7 and the closure element 24 is inserted in the respective receptacle 23, locking them stably and detachably.

[0028] In practice it has been found that the invention fully achieves the intended aim and objects, since the guiding assembly 1, by having two profiled elements 7 and a single pair of panels 8, can be assembled rapidly. The interlocking means with which the profiled elements 7 and the panels 8 are provided allow, together with the closure elements 24, to remove the panels 8 while ensuring stable assembly.

[0029] The invention thus conceived is susceptible of numerous modifications and variations, all of which are within the scope of the appended claims; all the details may further be replaced with other technically equivalent ones.

[0030] In the exemplary embodiments that have been described, individual characteristics, given in relation to specific exemplary embodiments, may actually be interchanged with other different characteristics that exist in other exemplary embodiments.

[0031] Moreover, it is noted that anything found to be already known during the patenting process is understood not to be claimed and to be the subject of a disclaimer.

[0032] In practice, the materials used, as well as the shapes and the dimensions, may be any according to requirements and the state of the art without thereby abandoning the scope of the protection of the appended claims.

[0033] The disclosures in Italian Patent Application No. BO2004A000762 from which this application claims pri-

ority are incorporated herein by reference.

[0034] Where technical features mentioned in any claim are followed by reference signs, those reference signs have been included for the sole purpose of increasing the intelligibility of the claims and accordingly such reference signs do not have any limiting effect on the interpretation of each element identified by way of example by such reference signs.

Claims

1. A guiding assembly for roll-up awnings constituted by a covering sheet (2) which can be rolled up onto a roller which is accommodated rotatably within a respective upper containment box, said sheet (2) being associated with the roller by means of one of its upper ends, each one of the two lateral edges of said sheet being provided with a sort of flexible set of teeth (3), which is guided so that it can slide within a longitudinal recess (4) of a corresponding rail (5), **characterized in that** it comprises two lateral supporting profiled elements (7), each of which forms a first half-shoulder (12) for said rail (5) and a first half-guide (10) for a transverse bar (11) associated with the lower end of said sheet (2), and comprises two panels (8), each of which forms a second half-shoulder (18), which is complementary to the first one, for said rail (5), and a second half-guide (19), which is complementary to the first one, for said bar (11), each one of said panels (8) being detachably engageable on a respective profiled element (7) by way of provided interlocking means.
2. The guiding assembly according to claim 1, **characterized in that** said interlocking means comprise at least one wing (9) on each profiled element (7) and at least one wing (9) on each panel (8), said wings (9) being inclined complementarily at a predefined angle.
3. The assembly according to claim 2, **characterized in that** said wings (9) have an enlarged end portion (21), which can engage with a corresponding seat (22) formed at the base of each one of said wings (9).
4. The guiding assembly according to one or more of the preceding claims, **characterized in that** said interlocking means comprise two wings (9) on each profiled element (7) and two wings (9) on each panel (8).
5. The guiding assembly according to claim 1, **characterized in that** each one of said profiled elements (7) forms a first abutment and a second abutment, which is complementary to the first one, for the base (6) of said rail (5).
6. The guiding assembly according to one or more of the preceding claims, **characterized in that** each one of said profiled elements (7) and each one of said panels (8), in the coupled configuration, form a receptacle (23) for the interlocking insertion of a closure element (24) of said guiding assembly (1).
7. The guiding assembly according to claim 6, **characterized in that** said closure element (24) is a rod made of a material such as rubber.
8. The guiding assembly according to claim 6, **characterized in that** said closure element (24) is a contoured rod made of metallic material.
9. The guiding assembly according to one or more of the preceding claims, **characterized in that** it comprises an upper closure plug (26) and a lower closure plug (27), which can be fixed onto each profiled element (7), each one of said plugs (26, 27) being affected by a slot (29), which is open on the inner side for the passage of said sheet (2) and constituting an abutment for the bar (11) guided between the profiled elements (7) and the panels (8).
10. The guiding assembly according to one or more of the preceding claims, **characterized in that** said bar (11) is affected by a longitudinal slot (30), which is open upward and has a transverse profile which is shaped complementarily with respect to a substantially rounded border (31), which is associated with the lower end of said sheet (2) which can be inserted in said slot (30).
11. The guiding assembly according to one or more of the preceding claims, **characterized in that** said bar (11) comprises laterally terminal guiding elements (29), each of which is affected by a slot (30a) which is open upward, corresponds to the slot (30), and has the same transverse profile, said guiding elements being adapted to accommodate the border (31) of the sheet (2) up to the vicinity of the rail (5).
12. The guiding assembly according to one or more of the preceding claims, **characterized in that** said profiled element (7) has a transverse cross-section which is substantially L-shaped, and **in that** the long portion of the L-shape has a substantially rectangular end region which cantilevers inward, said end region forming said first half-guide (10) for said bar (11) and, toward the short side of the L-shape, said first half-shoulder (12) for the rail (5), and **in that** the short side of the L-shape comprises, starting from an end portion (13), a cantilevered portion (14) which is substantially perpendicular to said short side, said cantilevered portion (14) being provided with a step (15) and subsequently with two of said wings (9) directed outward, for the detachable interlocking of said cor-

responding panel (8).

13. The guiding assembly according to one or more of the preceding claims, **characterized in that** each one of said profiled elements (7) comprises, on the long side of the L-shape, a longitudinal ridge (16), which forms said first abutment for the base (6) of the rail (5), and further comprises said second abutment, which is complementary to the first abutment and is formed by a flat terminal surface (17) of said cantilevered portion (14) of the short side of the L-shape. 5 10
14. The guiding assembly according to one or more of the preceding claims, **characterized in that** each one of said panels (8) has a transverse cross-section which is substantially I-shaped and comprises a respective substantially rectangular cantilevered end portion which, when the assembly (1) is assembled, is arranged mirror-symmetrically with respect to said end region of said profiled element (7), said end part forming said second half-shoulder (18) for said rail (5) and said second half-guide (19) for said bar (11), and comprises, on the other side, two of said wings (9), which are inclined complementarily for detachable interlocking on said profiled element (7), and an end wall (20), which faces, in the coupling configuration, the step (15) of the profiled element (7). 15 20 25
15. The guiding assembly according to one or more of the preceding claims, **characterized in that** said profiled element (7) and said panel (8), in the coupling configuration, form said receptacle (23) for said closure element (24) between said end portion (13) and said cantilevered portion (14) of the short side of the L-shape, and said end wall (20) of said panel (8). 30 35

40

45

50

55

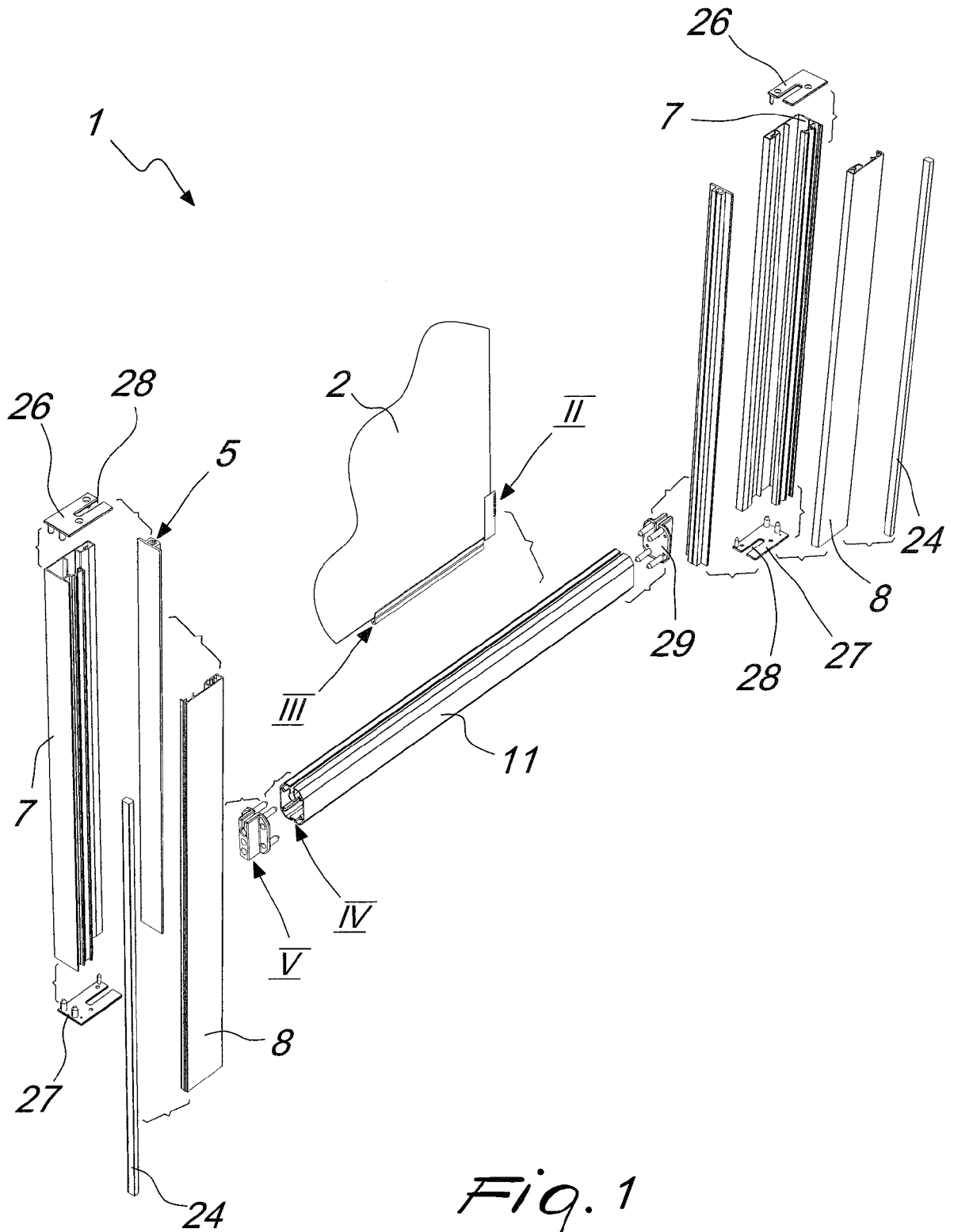

Fig. 1

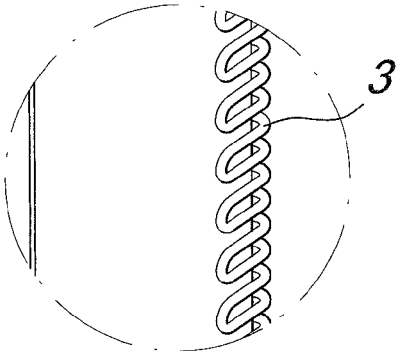

Fig. 2

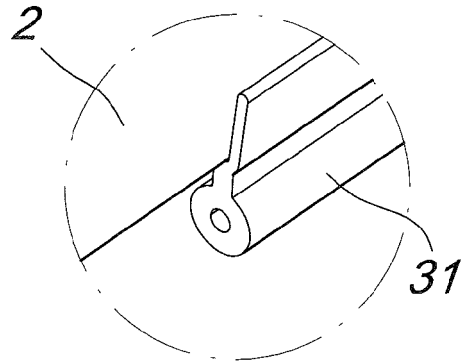

Fig. 3

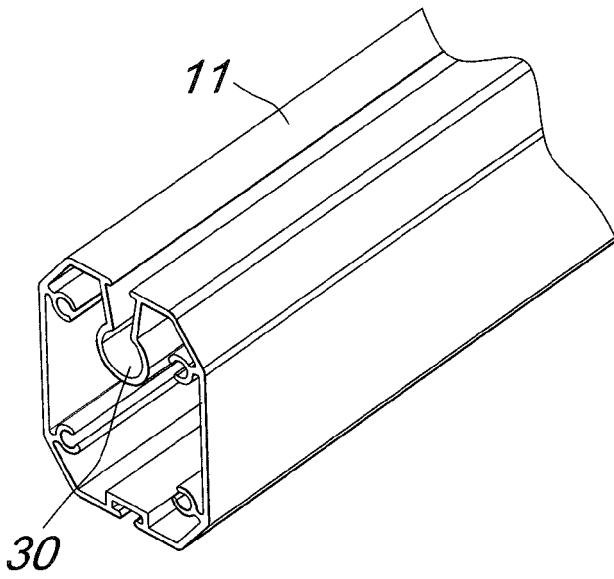

Fig. 4

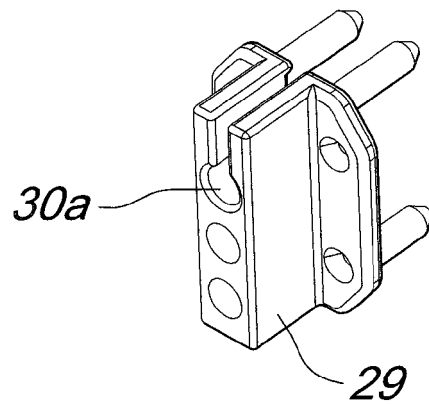

Fig. 5

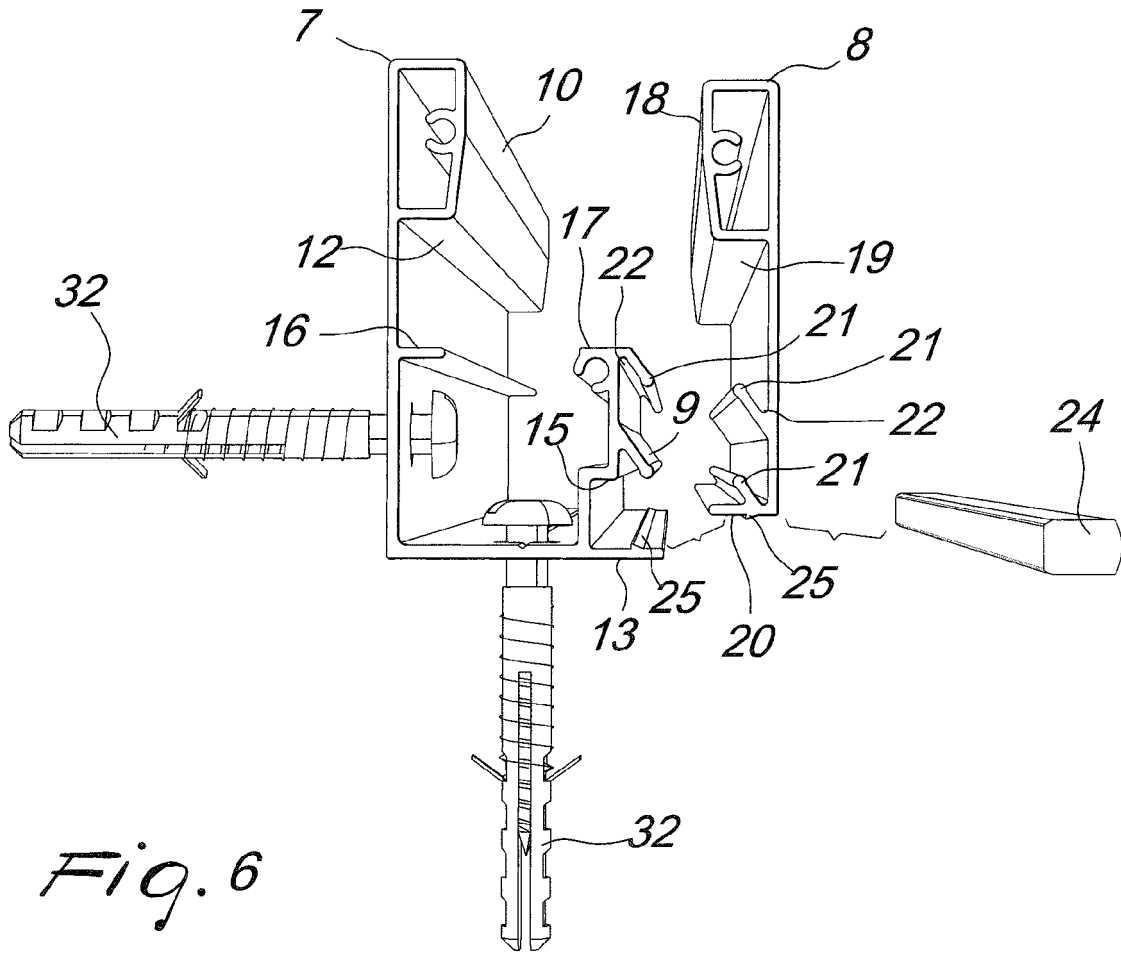

Fig. 6

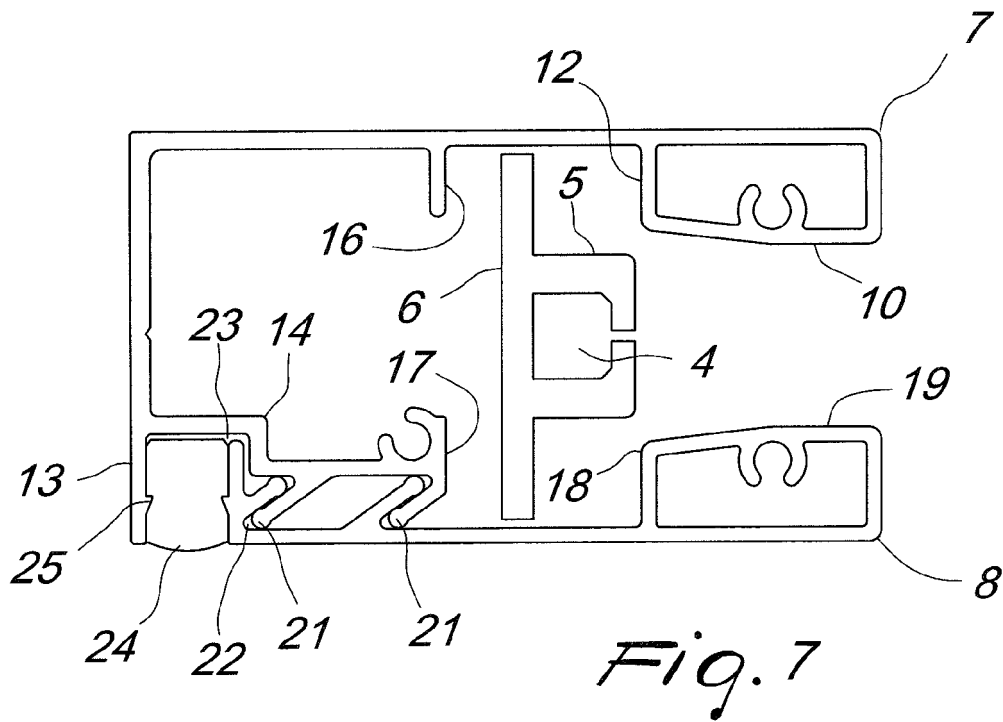

Fig. 7