

(19) World Intellectual Property
Organization
International Bureau



(43) International Publication Date
5 August 2004 (05.08.2004)

PCT

(10) International Publication Number
WO 2004/064548 A1

(51) International Patent Classification⁷: A24F 01/14

(21) International Application Number:
PCT/IL2003/001121

(22) International Filing Date:
31 December 2003 (31.12.2003)

(25) Filing Language: English

(26) Publication Language: English

(30) Priority Data:
154075 21 January 2003 (21.01.2003) IL

(71) Applicant and

(72) Inventor: NETZER, Omry [IL/IL]; 21 Akiva st., 43261
Ra'anana (IL).

(74) Agent: GOLD - PATENTS & FINANCIAL SERVICES
(1992) LTD; 43 Rubinstein st., 34987 Haifa (IL).

(81) Designated States (*national*): AE, AG, AL, AM, AT, AU, AZ, BA, BB, BG, BR, BW, BY, BZ, CA, CH, CN, CO, CR, CU, CZ, DE, DK, DM, DZ, EC, EE, EG, ES, FI, GB, GD, GE, GH, GM, HR, HU, ID, IL, IN, IS, JP, KE, KG, KP, KR, KZ, LC, LK, LR, LS, LT, LU, LV, MA, MD, MG, MK, MN, MW, MX, MZ, NI, NO, NZ, OM, PG, PH, PL, PT, RO, RU, SC, SD, SE, SG, SK, SL, SY, TJ, TM, TN, TR, TT, TZ, UA, UG, US, UZ, VC, VN, YU, ZA, ZM, ZW.

(84) Designated States (*regional*): ARIPO patent (BW, GH, GM, KE, LS, MW, MZ, SD, SL, SZ, TZ, UG, ZM, ZW), Eurasian patent (AM, AZ, BY, KG, KZ, MD, RU, TJ, TM), European patent (AT, BE, BG, CH, CY, CZ, DE, DK, EE, ES, FI, FR, GB, GR, HU, IE, IT, LU, MC, NL, PT, RO, SE, SI, SK, TR), OAPI patent (BF, BJ, CF, CG, CI, CM, GA, GN, GQ, GW, ML, MR, NE, SN, TD, TG).

Published:
— with international search report

For two-letter codes and other abbreviations, refer to the "Guidance Notes on Codes and Abbreviations" appearing at the beginning of each regular issue of the PCT Gazette.

(54) Title: SMOKING DEVICE

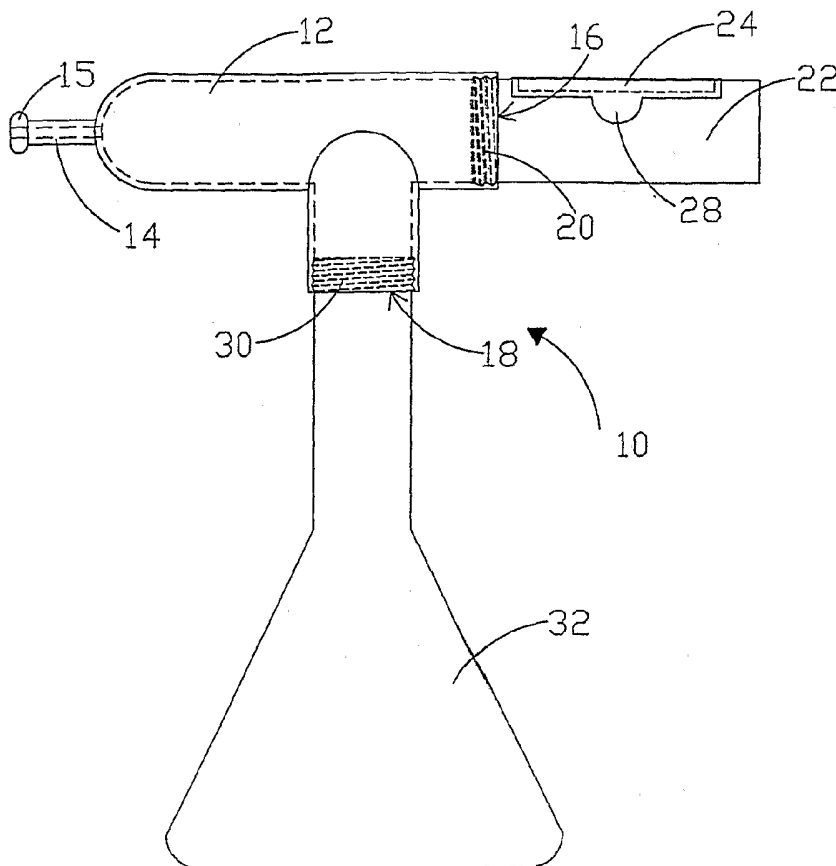

(57) Abstract: There is provided a personal and portable smoking device (10) which comprises a tube (12) provided with a first opening (20), a second opening (14) having a mouthpiece (15) through which smoke is inhaled and a plurality of disposable cartridges (22) with a port (28) through which burning products (24) engaged within the cartridge (22) are exposed to air. The cartridges (22) are connectable to the first opening of the tube (20) through one end. The smoking device (10) further comprises a container (32) with fluid aerodynamically connected to the tube, and a pipe (44) partially passing through the tube (12) and the second opening (18) and outwardly extended to be placed in the fluid. The user connects a cartridge (22) to the first opening (20) and burns the burning products (24). When the user inhales through the mouthpiece (15), the generated smoke from the combustion of the burning products (24) bubbles through the fluid in the connected container (32) and is inhaled through the mouthpiece (15).

WO 2004/064548 A1

SMOKING DEVICE

FIELD OF THE INVENTION

5

The present invention relates to smoking devices. More particularly, the present invention relates to personal and portable hookah-based smoking device having a changeable and disposable tobacco cartridge and a method of using the same.

10

BACKGROUND OF THE INVENTION

The traditional hookah or the water-pipe is a well known smoking device that was originally invented in Turkey and was used especially in oriental and middle-east countries. Since then, the hookah has become very popular in other cultures and penetrated into western countries for the last few decades. The hookah is related also to the traditional oriental custom of smoking in groups of several people in cafés or restaurants while using a single hookah having an inhaling pipe that is transferred from one individual to the others. Smoking hookah is a social custom that involves also the preparation of the tobacco mixture and the burning material as well as introducing the mixture and the burning material in a special part of the hookah.

The traditional hookahs as well as modern water-pipes generally comprise a bottle-like part that is adapted to receive water and a connectable tube having a portion that is adapted to receive the tobacco. The connectable tube is provided with a pipe having two openings wherein one of the openings is adapted to receive the smoke from the tobacco and the other end reaches the water in the bottle-like part so that smoke coming from the tobacco bubbles out through the water to the bottle and the connectable tube. The connectable tube is further provided with another flexible pipe through which

30

smoke is inhaled. The smoke passes through the water before it is inhaled by the smokers through a mouthpiece.

The passage of the tobacco smoke through water before inhaling the smoke into the mouth and lungs of the user has two objectives: First, some of
5 the materials in the smoke are absorbed in the water without losing the taste and aroma of the smoke. Therefore, the amount of harmful materials that reach the mouth and lungs of the user is reduced markedly. In fact, the water acts as a filter. Secondly, the water gives the smoke coolness that no cigarette, cigar or another pipe can provide.

10 One of the disadvantages of smoking a hookah in groups of people is that everyone has to smoke the same tobacco that has a certain taste and aroma. There are many types of tobacco as well as many types of fruit molasses and other flavor materials that smokers wish to mix in their tobacco. Each one of the mixtures has a certain taste and aroma. People develop
15 preferences towards a certain tobacco mix and do not want to smoke a tobacco that is chosen by other smokers. This brought about the minimization of the hookah and presentation of a small hookah for which the user prepares his own favorite tobacco.

Another disadvantage of using a hookah in groups of people is that
20 transferring the hookah from mouth to mouth is non-hygienic. There are many people that do not want to smoke from a water pipe that was used by other people. Again, the minimized hookah can partially solve the problem.

For smoking the traditional hookah as well as the minimized one, the smoker has to prepare his own mixture of tobacco and other tastes and
25 flavors as well as the burning material while making some preparation in order to enable smoking. Not all people have the time or the delight to prepare the smoking mixtures and would have wanted to smoke tobacco and enjoy the advantages of smoking a hookah without having to make any preparations. Moreover, there is a need to provide a portable smoking device that is
30 hookah-based and can be smoked at work and relatively rapidly without having to go through the tedious preparation of the mixtures and the burning materials.

SUMMARY OF THE INVENTION

It is an object of the present invention to provide a new and unique hookah-based smoking device that is personal and portable.

5 It is another object of the present invention to provide a new and unique hookah-based smoking device having a tobacco cartridge that can be disposed of after use and changed to another tobacco cartridge.

It is yet another object of the present invention to provide a new hookah-based smoking device that is hygienic.

10 An additional object of the present invention is to provide a method of using the smoking device of the present invention.

It is therefore provided in accordance with a preferred embodiment of the present invention a smoking device which smoke pass through fluid, said smoking device comprising:

15 a tube provided with a first opening, a second opening and a mouthpiece through which the smoke is inhaled;

at least one of a plurality of cartridges connectable to said first opening through one end and wherein each one of said plurality of cartridges is provided with a port through which the
20 burning products are exposed to air;

burning products engaged within said at least one of a plurality of cartridges;

25 a container adapted to receive the fluid wherein said container is connectable through an open upper end to said second opening and wherein said container is aerodynamically connected to said tube;

30 a pipe partially passing through said tube and said second opening and outwardly extended to be placed in the fluid received in said container, wherein said pipe is aerodynamically communicating with one of said plurality of cartridges that is

connected to first opening through a hole provided at said one end;

5 whereby after the user connects one of said plurality of cartridges to said first opening and burns the burning products, smoke generated from the combustion of the burning products passes through said hole into said pipe, and bubbles through the fluid in the connected container and then transferred into the tube and inhaled through said mouthpiece by the user, and wherein after the burning products are burnt out, the user disposes of the cartridge and replaces it with another one of said
10 plurality of cartridges.

Furthermore, in accordance with yet another preferred embodiment of the present invention, the burning products comprise tobacco and coal.

15 Furthermore, in accordance with yet another preferred embodiment of the present invention, each one of said plurality of cartridges is divided into an upper part and a bottom part by a perforated sheet and wherein said tobacco resides in said bottom part and said coal resides in said upper part.

Furthermore, in accordance with yet another preferred embodiment of the present invention, said tobacco is partially confined within a mesh screen so as to prevent its spreading.

20 Furthermore, in accordance with yet another preferred embodiment of the present invention, said coal is in the shape of a stick that is positioned on top of said perforated sheet and is provided with a stopper that prevents its fully ejection from the cartridge.

25 Furthermore, in accordance with yet another preferred embodiment of the present invention, said tobacco is mixed with fruit molasses or flavor materials.

30 Furthermore, in accordance with yet another preferred embodiment of the present invention, each one of said plurality of cartridges is provided with a removable seal that seals said hole when the cartridge is not connected to said tube.

Furthermore, in accordance with yet another preferred embodiment of the present invention, said port is sealed with a removable seal.

Furthermore, in accordance with yet another preferred embodiment of the present invention, said removable seal is adhered to edges of said port.

5 Furthermore, in accordance with yet another preferred embodiment of the present invention, each one of said plurality of cartridges is further provided with an additional opening substantially opposite said one end, wherein said additional opening is positioned so as to facilitate initiation of combustion of said burning products.

10 Furthermore, in accordance with yet another preferred embodiment of the present invention, each one of said plurality of cartridges is divided into an upper part and a bottom part by a perforated sheet and wherein the burning products comprise tobacco that resides in said bottom part and coal that resides in said upper part and wherein said additional opening is positioned
15 so as to allow said coal to be partially withdrawn through said additional opening.

Furthermore, in accordance with yet another preferred embodiment of the present invention, each one of said plurality of cartridges is screwed to a corresponding screw provided in said first opening.

20 Furthermore, in accordance with yet another preferred embodiment of the present invention, said open upper end is screwed to a corresponding screw provided in said second opening.

Furthermore, in accordance with yet another preferred embodiment of the present invention, said container is provided with a broad base.

25 Furthermore, in accordance with yet another preferred embodiment of the present invention, said container is an elongated tube provided with a flat base.

Furthermore, in accordance with yet another preferred embodiment of the present invention, said fluid is water.

Furthermore, in accordance with yet another preferred embodiment of the present invention, said at least one of a plurality of cartridges is made of a ceramic material.

5 Furthermore, in accordance with yet another preferred embodiment of the present invention, said mouthpiece comprises a stem and a bit.

Furthermore, in accordance with yet another preferred embodiment of the present invention, said container is provided with a cover adapted to cover said open upper end when said smoking device is not in use.

10 Furthermore, in accordance with yet another preferred embodiment of the present invention, said first opening is provided with a plug through which said pipe passes.

Furthermore, in accordance with yet another preferred embodiment of the present invention, said second opening is provided with a plug and wherein said plug is provided with a hole through which said pipe passes and
15 at least one bore allowing said container to aerodynamically communicate with said tube.

Furthermore, in accordance with yet another preferred embodiment of the present invention, said at least one bore is provided with a valve adapted to prevent fluid from the container to enter said tube.

20 Furthermore, in accordance with yet another preferred embodiment of the present invention, said valve is a conical element provided with a confined float.

Furthermore, in accordance with yet another preferred embodiment of the present invention, said float is a ball.

25 Furthermore, it is provided in accordance with yet another preferred embodiment of the present invention a disposable cartridge to be used in a personal smoking device in which smoke passes through fluid, said disposable cartridge comprises:

one end adapted to be connected to the smoking device;

burning products engaged within said disposable cartridge;
port through which said burning products are exposed to air;

Furthermore, in accordance with another preferred embodiment of the present invention, said disposable cartridge is further provided with an
5 additional opening substantially opposite said one end, wherein said additional opening is positioned so as to facilitate initiation of combustion of said burning products.

Furthermore, in accordance with another preferred embodiment of the present invention, said disposable cartridge is divided into an upper part and a
10 bottom part by a perforated sheet and wherein the burning products comprise tobacco that resides in said bottom part and coal that resides in said upper part and wherein said additional opening is positioned so as to allow said coal to be partially withdrawn through said additional opening.

It is furthermore provided in accordance with yet another preferred
15 embodiment of the present invention, a method for smoking a smoking device in which smoke passes through fluid, said method comprising:

providing a smoking device comprising:

a tube provided with a first opening, a second opening,
and a mouthpiece through which the smoke is inhaled;

20 at least one of a plurality of cartridges provided with burning products, said plurality of cartridges adapted to allow combustion of the burning products engaged within, wherein each one of said plurality of cartridges is connectable to said first opening through one end and wherein each one of said
25 plurality of cartridges is provided with a port sealed with a first removable seal;

a container adapted to receive the fluid wherein said
30 container is connectable through an open upper end to said second opening and wherein said container is aerodynamically connected to said tube;

5 a pipe partially passing through said tube and said second opening and outwardly extended to be placed in the fluid received in said container, wherein said pipe is aerodynamically communicating with each one of said plurality of cartridges that is connected to first opening through a hole provided at said one end;

a second removable seal provided on said hole;

removing said second removable seal from one of said plurality of cartridges;

10 connecting one of said plurality of cartridges through one end to said first opening;

removing said second seal;

providing fluid in said container;

connecting said container to said second opening;

15 removing said first seal;

lighting said burning products;

inhaling the smoke through said mouthpiece;

disconnecting said one of a plurality of cartridges after said burning products are burnt;

20 disposing said one of a plurality of cartridges;

providing another one of said plurality of cartridges;

whereby each one of said plurality of cartridges is connected to said tube and disposed after used in the same manner.

25 Furthermore, in accordance with yet another preferred embodiment of the present invention, said method further comprises providing to each one of said plurality of cartridges an additional opening opposite said one end, said additional opening is adapted to facilitate initiation of combustion of the burning products.

Furthermore, in accordance with yet another preferred embodiment of the present invention, each one of said plurality of cartridges is divided into an upper part and a bottom part by a perforated sheet and wherein the burning products comprise tobacco that resides in said bottom part and coal that resides in said upper part and wherein said additional opening is positioned so as to allow said coal to be partially withdrawn through said additional opening.

Furthermore, in accordance with yet another preferred embodiment of the present invention, each one of said plurality of cartridges is divided into an upper part and a bottom part by a perforated sheet and wherein the burning products comprise tobacco that resides in said bottom part and coal that resides in said upper part.

Additionally, in accordance with yet another preferred embodiment of the present invention, said tobacco is confined in a mesh screen so as to prevent its spreading.

BRIEF DESCRIPTION OF THE FIGURES

20

In order to better understand the present invention and appreciate its practical applications, the following Figures are attached and references herein. Like components are denoted by like reference numerals.

It should be noted that the figures are given as examples and preferred embodiments only and in no way limit the scope of the present invention as defined in the appending Description and Claims.

Figures 1a - c illustrate a frontal view, a side view and an upper view, respectively, of a hookah-based smoking device in accordance with a preferred embodiment of the present invention.

30

5 Figures 2a - c illustrate cross sectional frontal view and upper view of the tube of the hookah-based smoking device shown in Figure 1. An enlarged view of a valve provided in the plug of the smoking device is shown in Figure 2c.

10 Figure 3 illustrates a frontal view of a hookah-based smoking device in accordance with another preferred embodiment of the present invention.

15 Figure 4 illustrates a cross sectional view of the two optional containers in accordance with preferred embodiments of the present invention, disassembled from the hookah-based smoking device.

20 Figures 5a - e illustrate different views as well as cross sectional views of the tobacco cartridge of the hookah-based smoking device shown in Figure 1.

25 Figures 6 a - f illustrate different views and cross sectional views of a tobacco cartridge in accordance with another preferred embodiment of the present invention.

 Figure 7 illustrates the smoking device shown in Figure 1, disassembled.

DETAILED DESCRIPTION OF THE INVENTION AND THE FIGURES

The present invention provides a new and unique smoking device that is based on the traditional hookah; however, the smoking device of the present invention is portable. The Hookah-based smoking device is also personal in the sense that it is not designed to be transferred between a few smokers and an individual smoker can smoke it alone.

An additional unique feature of the hookah-based smoking device is in the possibility to provide the tobacco in a specially designed cartridge that is connected to the smoking device. The cartridge can contain tobacco having different tastes and aromas. This feature eliminates the need of the smoker to mix and prepare the tobacco mixture and the burning material on his own. The tobacco mixture and the burning material are provided in a disposable cartridge that is changeable. Cartridges of various tobacco types are available so that the smoker can change the cartridge according to his needs and taste.

In a preferred embodiment of the present invention, the hookah-based smoking device comprises a tube through which the user inhales the smoke. The smoke is originated from a connectable tobacco cartridge in which the burning products and preferably tobacco burns using a burning material such as coal. The coal has to be of such a kind that burns quickly. The tobacco cartridge is open to the air so as to facilitate an effective burning of the tobacco and the burning material. The tobacco cartridge can preferably be screwed onto the tube. The cartridge is disposable. The hookah-based smoking device further comprises a container that is connected to the tube. The container is adapted to receive a fluid such as water. The smoke generated in the tobacco cartridge enters the tube through a pipe having an opening that is positioned in the water in the container. The smoke that passes through the pipe bubbles out from the opening that is positioned in the water. The user, which inhales the smoke, receives smoke that is cooled by the water and is partially lack in some of the ingredients that are not desirable and are being absorbed by the water while passing through them. It should be

emphasized that the cartridge can be filled with materials other than tobacco. It can be filled with herbs of any kind such as healing or medicine herbs.

Reference is now made to Figures 1a, b, and c illustrating a frontal view, a side view and an upper view of a hookah-based smoking device in accordance with a preferred embodiment of the present invention. Smoking device 10 comprises a tube 12 having a mouthpiece preferably provided with a stem 14 and a bit 15 through which smoke that is received in tube 12 can be inhaled by a user. Tube 12 is provided with two openings; a first opening 16, which is concentric to the tube, and a second opening 18, which is preferably provided on the side of the tube. First opening 16 is provided with a screw 20 to which a complementary screw of a tobacco cartridge 22 can be connected. Tobacco cartridge 22 is concentric with respect to tube 12 and is provided with a side port 24. Side port 24 is provided with a seal 26 having a clasp 28 with which seal 26 can be removed of tobacco cartridge 22 (the seal is clearly shown in Figure 1c). Seal 26 is preferably a flexible sheet that is adhered on the edges of side port 24. A comprehensive explanation regarding tobacco cartridge 22 and other optional embodiments of tobacco cartridges are disclosed herein after.

Second opening 18 of tube 12 is provided with a screw 30 to which a complementary screw of a container 32 can be connected. Smoke generated in tobacco cartridge 22 is transferred into tube 12 through container 32. Container 32 is preferably filled with water (not shown in Figure 1) so that the smoke bubbles through the water before entering tube 12. While the smoke bubbles pass through the water, some of the materials that are generated by the burning process of the tobacco are absorbed by the water that acts as a filter. Moreover, the smoke in the bubbles is cooled by the water and the user inhales cooled smoke.

It is noted that the container may be filled with any fluid that may act as an absorbent or a solution that comprises an absorbent material as well as a mixture within an absorbent material is mixed. However, water is generally a common and efficient absorbent that can be found anywhere.

In order to better understand the passage of the smoke generated in the tobacco cartridge into the tube through the container, reference is now made to Figure 2 illustrating a cross sectional frontal view of the tube of the hookah-based smoking device shown in Figure 1. First opening 16 is provided with a plug 40 having a bore 42. A substantially L-shaped pipe 44, having a first opening 47 and a second opening 48, pass through tube 12. First opening 47 is placed in bore 42 of plug 40 so that smoke generated in tobacco cartridge (not shown in Figure 2) is communicating with pipe 44 and there is no direct aerodynamic connection between the tobacco cartridge and tube 12. A portion of pipe 44 that comes out of second opening 18 is positioned outside tube 12. The portion of pipe 44 that is outside tube 12 is adapted to be positioned in container 32 that is screwed onto screw 30 (the container is not shown in Figure 2). Second opening 48 is positioned in container 32 inside the water that is received in the container.

When the user inhales through the mouthpiece of smoking device 10, the pressure in the cavity of tube 12 is reduced as well as the pressure in container 32. Therefore, smoke is driven to pass through pipe 44 from tobacco cartridge 22 and into container 32. The smoke bubbles through the water in the container in order to equilibrate the pressure in the container and in the tube. Container 32 is fluidically connected to tube 12 so that the smoke that bubbles out from pipe 44 is free to fill the cavity in tube 12 and to be inhaled by the user through bit 15.

Since the container is filled with water and there is a possibility that the water will enter tube 12 if smoking device 10 is held in a declined manner, opening 18 is provided with a plug 50. Plug 50 is provided with a first hole 52 through which pipe 44 passes and preferably two additional bores provided with valves 54. In a preferred embodiment that is shown in Figure 2, valves 54 are operated such as a snorkel. The valves are clearly shown in Figure 2c, which is an enlargement of the valves in the bores. The walls of the bores as well as the valves are conical so that the upper openings of the valves that face tube 12 are smaller than the bottom openings that face container 32. Each one of valves 54 is provided with a light ball 56 that is caged in the valve

using preferably four hooks 60. When the water is in the container and the user inhales through the mouthpiece, the smoke is free to pass through valves 54. If the smoking device is inclined and the water reaches opening 18, light balls 56, which are light enough to float on the water surface, are upwardly
5 advancing towards the upper openings of valves 54. Since the diameter of the balls 56 is slightly longer than the diameter of the upper openings of the valve, balls 56 seal the openings so that water cannot enter tube 12.

In order for the hookah-based smoking device 10 to be stable in a position where the device is not decline, container 32 is shaped so that it is
10 provided with a broad base. The device can be mounted on a surface while it is supported by the broad base and water cannot enter the tube.

Reference is now made to Figure 3 illustrating a frontal view of a hookah-based smoking device in accordance with another preferred embodiment of the present invention. Hookah-based smoking device 100 generally comprises
15 similar parts as smoking device 10, however, smoking device 100 is provided with a tube-like container 102 that is screwed onto screw 30. Tube-like container is provided with a flat base 104 that supports smoking device 100 when it is mounted on a surface. In this way, the possibility of water entering the tube is lessened.

Reference is now made to Figure 4 illustrating a cross sectional view of
20 the two optional containers in accordance with preferred embodiments of the present invention, disassembled from the hookah-based smoking device. Generally, the container that is adapted to receive water can be of any shape. As mentioned herein, container 32 as well as container 102 are provided with
25 a broad base adapted to support the smoking device when placed on a surface. When the containers are disassembled from the smoking device, they can be supported also by the broad base. A cover 106 is provided as an accessory to the hookah-based smoking device assembly so that when the smoking device is not in use, the container is kept closed. Cover 106 is
30 provided with a screw 108 that corresponds the screw that is provided on the container.

As mentioned herein before, one of the objects of the water is to filter the smoke. Some of the materials in the smoke bubbles that pass through the water are absorbed in the water. The amount of absorbed materials depends on the time the bubbles travels in the water, a factor that depends on the height of the water above opening 48 of pipe 44 (the pipe is not shown in Figure 4). For example, the time in which the bubbles travel in water 110 in container 102 is longer than the time the bubbles travel in the water 112 in container 32. The user can choose the containers shape and size according to his needs and desires as well as the height of the water. The same is applied on the coolness of the smoke that will be inhaled by the user. The more time the bubbles are in the water, the cooler the smoke will be.

The tobacco cartridge can be an empty cartridge that is filled by the user with tobacco and burning material or a cartridge that can be supplied as a disposable cartridge that can be changed in every use.

Reference is now made to Figures 5a - e illustrating different views as well as cross sectional views of the tobacco cartridge of the hookah-based smoking device shown in Figure 1. Figures 5 a, b illustrate an upper and frontal views of tobacco cartridge 22 provided with seal 26. Seal 26 is removed from port 24 when the user wishes to use the smoking device while port 24 has two purposes. The first is to light the burning material and the tobacco that is placed within tobacco cartridge 22 and the second purpose is to allow air with oxygen to be in contact with the burning material so as to enable the heating of the tobacco. Tobacco cartridge 22 has a connection 150 that is provided with a screw 157 that is screwed onto a tube such as tube 12 (not shown in Figure 5). Tobacco cartridge 22 is provided with a seal 154 that seals the cartridge when the smoking device is not in use in order to preserve the tobacco's freshness inside the cartridge. Seal 154 can be replaced by a cover that is screwed onto screw 157. When the cartridge is provided with a single port for lighting, the preferred method of lighting the coal is to hold the cartridge upside down while it is lighted and turning it back afterwards.

Figures 5c and d are frontal and side cross sectional views of tobacco cartridge 22, respectively. Tobacco cartridge 22 is provided with tobacco 156 that resides at the bottom part of the cartridge. Tobacco 156 can be of any kind or can be a mixture of tobacco and other materials that enriches the taste and the aroma of the tobacco. Tobacco 156 is confined in the cartridge so it will not spread out upon removal of seal 154 by a mesh screen 170 that is provided adjacent a hole 168 on the bottom part of the cartridge. Hole 168 allows communication of smoke between the cartridge where the tobacco resided and pipe 44 that is adjacent to connection 150 that connects the cartridge and the tube. A mesh screen 172 adjacent to the bottom of cartridge 22 is adapted to prevent the tobacco from spreading out. Burning material 158 that is preferably coal is placed on top of tobacco 156 so that when burning material 158 is lightened and burns, tobacco 156 is heated. As can be seen from Figure 5d, burning material is preferably designed as a stick so as to facilitate clean and uniform combustion.

A perforated sheet 160 is placed between tobacco 156 and burning material 158. Figure 5e is an upper cross sectional view of tobacco cartridge 22. Perforated sheet 160 is clearly shown in the figure. Perforated sheet 160 is adapted to separate tobacco 156 and burning material 158 so that they will not mix and the taste of the tobacco will be purer. The perforations facilitate the smoke from the burning material to pass through the tobacco as well as oxygen from the air to be in good contact with the tobacco.

It is optional to provide a tobacco cartridge having separate openings; a first opening for lighting the burning material and a second opening allowing air to be in contact with the burning material.

Reference is now made to Figures 6 a-f illustrating different views and cross sectional views of a tobacco cartridge in accordance with another preferred embodiment of the present invention. In tobacco cartridge 200 side port 24 is adapted only for allowing air to be in contact with the coal and the tobacco so as to facilitate efficient combustion. In order to light the coal, an additional opening 202 is provided opposite connection 150. A coal stick 204

is accommodated within the upper part of tobacco cartridge 200. Coal stick 204 can be withdrawn from the cartridge through additional opening 202 so as to facilitate its lighting (clearly shown in Figure 6f which is a side view of the cartridge). Coal stick 204 is provided with a stopper 206 that prevents the complete ejection of the coal stick from tobacco cartridge 200. Additional opening 202 is provided with a screwed cover 208 that keeps the cartridge closed at all times except the time the coal is lighted.

It is emphasized again that the tobacco cartridge in the hookah-based smoking device can be designed as a disposable cartridge so that plurality of cartridges in which different types of burning products are provided, is supplied. Each cartridge can be provided with the tobacco or tobacco mixture of certain taste and aroma. The user can change the cartridge when the tobacco is fully burnt or when he desires for another taste. The tobacco cartridge is disposable so that when the tobacco is fully burnt, the user disposes of the cartridge and connects another one to the tube of the smoking device. The other option is to supply an empty tobacco cartridge in which the user fills in the tobacco as well as the burning material. The tobacco cartridges are preferably made of a material that is adapted to allow combustion of the burning products that are engaged within. It is preferably made from a ceramic material, however any other material is covered by the scope of the present invention.

Reference is now made to Figure 7, illustrating the smoking device shown in Figure 1, disassembled. In the method of the present invention, the seal that closes connection 150 (seal 154) is removed before the cartridge is screwed onto opening 16. After the cartridge is connected to the tube, container 32 is filled with water (the water is not shown in Figure 7) and is ready to be screwed onto opening 18 while pipe 44 is positioned in the water. Then port 24 of tobacco cartridge 22 is removed and the coal can be lighted so that air and eventually smoke can be inhaled by the user through bit 15. It is optional to provide the container with water or with any other fluid that act as a filter as mentioned herein before.

It is an optional to provide cartridges having a diameter that corresponds the diameter of the container's upper opening so that before disposal of the cartridge, it is inserted into the fluid container to be cooled.

5 It should be noted that the burning products may be tobacco or tobacco mixtures. Any mixture of tobacco and other materials such as fruit molasses and other flavor materials or other herbs that are desired to be smoked are covered by the scope of the present invention. The burning material that burns the tobacco or tobacco mixture can be coal, however any other appropriate material can be used in order to establish combustion.

10 It should be clear that the description of the embodiments and attached Figures set forth in this specification serves only for a better understanding of the invention, without limiting its scope as covered by the following Claims.

15 It should also be clear that a person skilled in the art, after reading the present specification can make adjustments or amendments to the attached Figures and above described embodiments that would still be covered by the following Claims.

C L A I M S

1. A smoking device which smoke pass through fluid, said smoking device comprising:

5 a tube provided with a first opening, a second opening and a mouthpiece through which the smoke is inhaled;

at least one of a plurality of cartridges connectable to said first opening through one end and wherein each one of said plurality of cartridges is provided with a port through which the
10 burning products are exposed to air;

burning products engaged within said at least one of a plurality of cartridges;

a container adapted to receive the fluid wherein said container is connectable through an open upper end to said second opening and wherein said container is aerodynamically
15 connected to said tube;

a pipe partially passing through said tube and said second opening and outwardly extended to be placed in the fluid received in said container, wherein said pipe is aerodynamically
20 communicating with one of said plurality of cartridges that is connected to first opening through a hole provided at said one end;

whereby after the user connects one of said plurality of cartridges to said first opening and burns the burning products, smoke generated
25 from the combustion of the burning products passes through said hole into said pipe, and bubbles through the fluid in the connected container and then transferred into the tube and inhaled through said mouthpiece by the user, and wherein after the burning products are burnt out, the user disposes of the cartridge and replaces it with another one of said
30 plurality of cartridges.

2. The smoking device as claimed in Claim 1, wherein the burning products comprise tobacco and coal.
- 5 3. The smoking device as claimed in Claim 2, wherein each one of said plurality of cartridges is divided into an upper part and a bottom part by a perforated sheet and wherein said tobacco resides in said bottom part and said coal resides in said upper part.
- 10 4. The smoking device as claimed in Claim 3, wherein said tobacco is partially confined within a mesh screen so as to prevent its spreading.
5. The smoking device as claimed in Claim 3, wherein said coal is in the shape of a stick that is positioned on top of said perforated sheet and is provided with a stopper that prevents its full ejection from the
15 cartridge.
6. The smoking device as claimed in Claim 2, wherein said tobacco is mixed with fruit molasses or flavor materials.
- 20 7. The smoking device as claimed in Claim 1, wherein each one of said plurality of cartridges is provided with a removable seal that seals said hole when the cartridge is not connected to said tube.
- 25 8. The smoking device as claimed in Claim 1, wherein said port is sealed with a removable seal.

9. The smoking device as claimed in Claim 8, wherein said removable seal is adhered to edges of said port.
10. The smoking device as claimed in Claim 1, wherein each one of said plurality of cartridges is further provided with an additional opening substantially opposite said one end, wherein said additional opening is positioned so as to facilitate initiation of combustion of said burning products.
- 10 11. The smoking device as claimed in Claim 10, wherein each one of said plurality of cartridges is divided into an upper part and a bottom part by a perforated sheet and wherein the burning products comprise tobacco that resides in said bottom part and coal that resides in said upper part and wherein said additional opening is positioned so as to allow said coal to be partially withdrawn through said additional opening.
- 15
12. The smoking device as claimed in Claim 1, wherein each one of said plurality of cartridges is screwed to a corresponding screw provided in said first opening.
- 20
13. The smoking device as claimed in Claim 1, wherein said open upper end is screwed to a corresponding screw provided in said second opening.
- 25 14. The smoking device as claimed in Claim 1, wherein said container is provided with a broad base.
15. The smoking device as claimed in Claim 1, wherein said container is an elongated tube provided with a flat base.

16. The smoking device as claimed in Claim 1, wherein said fluid is water.
17. The smoking device as claimed in Claim 1, wherein said at least one of
5 a plurality of cartridges is made of a ceramic material.
18. The smoking device as claimed in Claim 1, wherein said mouthpiece
comprises a stem and a bit.
- 10 19. The smoking device as claimed in Claim 1, wherein said container is
provided with a cover adapted to cover said open upper end when said
smoking device is not in use.
- 15 20. The smoking device as claimed in Claim 1, wherein said first opening is
provided with a plug through which said pipe passes.
- 20 21. The smoking device as claimed in Claim 1, wherein said second
opening is provided with a plug and wherein said plug is provided with
a hole through which said pipe passes and at least one bore allowing
said container to aerodynamically communicate with said tube.
- 25 22. The smoking device as claimed in Claim 1, wherein said at least one
bore is provided with a valve adapted to prevent fluid from the
container to enter said tube.
23. The smoking device as claimed in Claim 22, wherein said valve is a
conical element provided with a confined float.

24. The smoking device as claimed in Claim 23, wherein said float is a ball.
25. A disposable cartridge to be used in a personal smoking device in which smoke passes through fluid, said disposable cartridge
5 comprises:
one end adapted to be connected to the smoking device;
burning products engaged within said disposable cartridge;
port through which said burning products are exposed to air;
- 10 26. The disposable cartridge as claimed in Claim 25, wherein said disposable cartridge is further provided with an additional opening substantially opposite said one end, wherein said additional opening is positioned so as to facilitate initiation of combustion of said burning products.
- 15 27. The disposable cartridge as claimed in Claim 26, wherein said disposable cartridge is divided into an upper part and a bottom part by a perforated sheet and wherein the burning products comprise tobacco that resides in said bottom part and coal that resides in said upper part
20 and wherein said additional opening is positioned so as to allow said coal to be partially withdrawn through said additional opening.
28. A method for smoking a smoking device in which smoke passes through fluid, said method comprising:
25 providing a smoking device comprising:
a tube provided with a first opening, a second opening,
and a mouthpiece through which the smoke is inhaled;

5 at least one of a plurality of cartridges provided with burning products, said plurality of cartridges adapted to allow combustion of the burning products engaged within, wherein each one of said plurality of cartridges is connectable to said first opening through one end and wherein each one of said plurality of cartridges is provided with a port sealed with a first removable seal;

10 a container adapted to receive the fluid wherein said container is connectable through an open upper end to said second opening and wherein said container is aerodynamically connected to said tube;

15 a pipe partially passing through said tube and said second opening and outwardly extended to be placed in the fluid received in said container, wherein said pipe is aerodynamically communicating with each one of said plurality of cartridges that is connected to first opening through a hole provided at said one end;

a second removable seal provided on said hole;

20 removing said second removable seal from one of said plurality of cartridges;

connecting one of said plurality of cartridges through one end to said first opening;

removing said first seal;

providing fluid in said container;

25 connecting said container to said second opening;

removing said first seal;

lighting said burning products;

inhaling the smoke through said mouthpiece;

disconnecting said one of a plurality of cartridges after said burning products are burnt;

disposing said one of a plurality of cartridges;

providing another one of said plurality of cartridges;

5 whereby each one of said plurality of cartridges is connected to said tube and disposed after used in the same manner.

10 29. The method as claimed in Claim 28, wherein said method further comprises providing to each one of said plurality of cartridges an additional opening opposite said one end, said additional opening is adapted to facilitate initiation of combustion of the burning products.

15 30. The method as claimed in Claim 29, wherein each one of said plurality of cartridges is divided into an upper part and a bottom part by a perforated sheet and wherein the burning products comprise tobacco that resides in said bottom part and coal that resides in said upper part and wherein said additional opening is positioned so as to allow said coal to be partially withdrawn through said additional opening.

20 31. The method as claimed in Claim 28, wherein each one of said plurality of cartridges is divided into an upper part and a bottom part by a perforated sheet and wherein the burning products comprise tobacco that resides in said bottom part and coal that resides in said upper part.

25 32. The method as claimed in Claim 31, wherein said tobacco is confined in a mesh screen so as to prevent its spreading.

Figure 1a

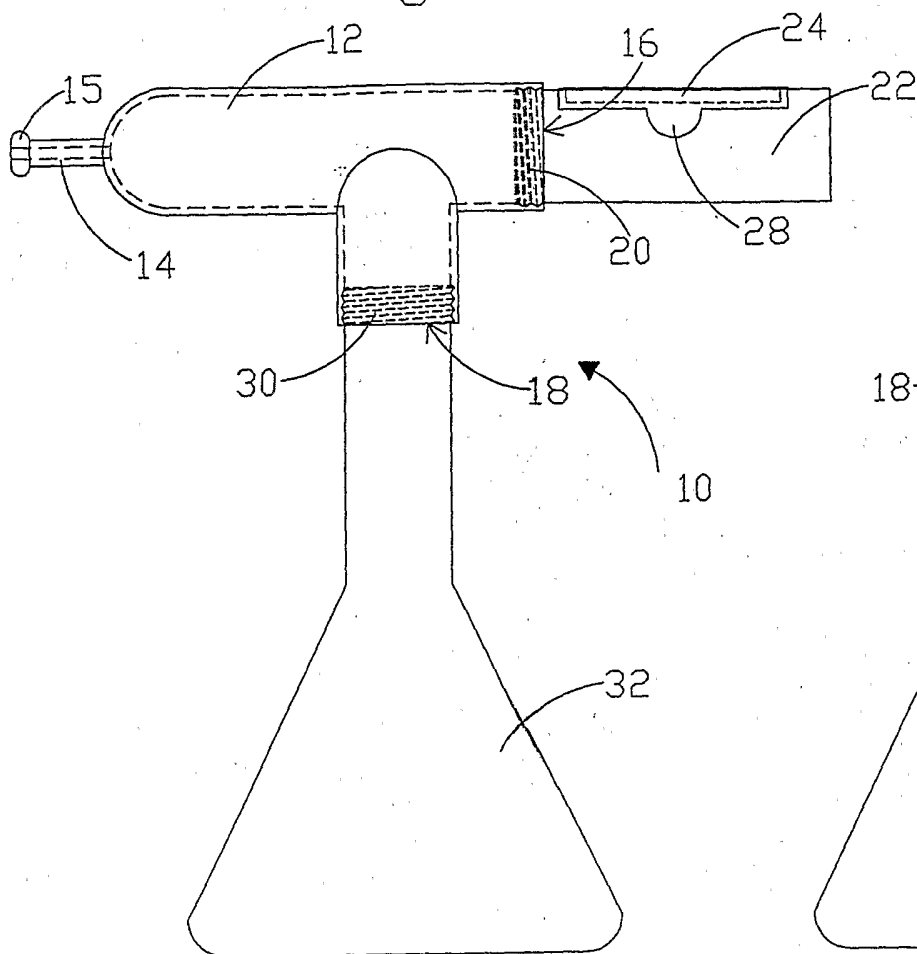

Figure 1b

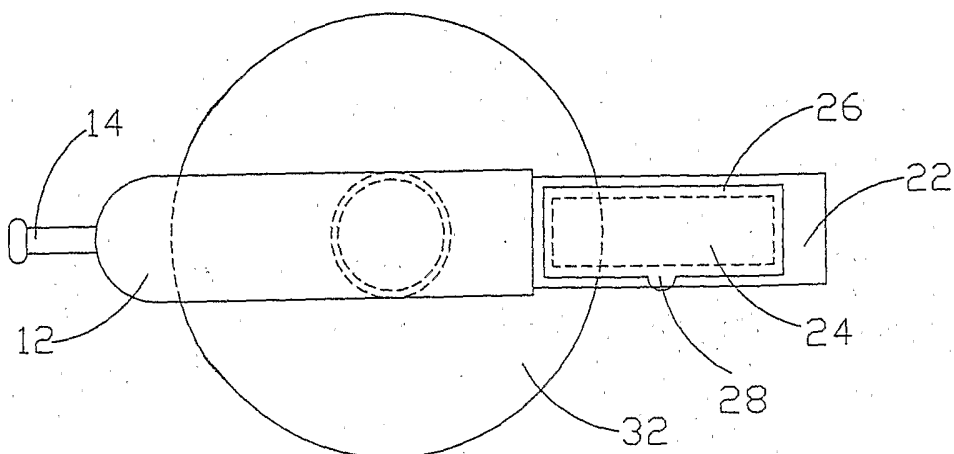
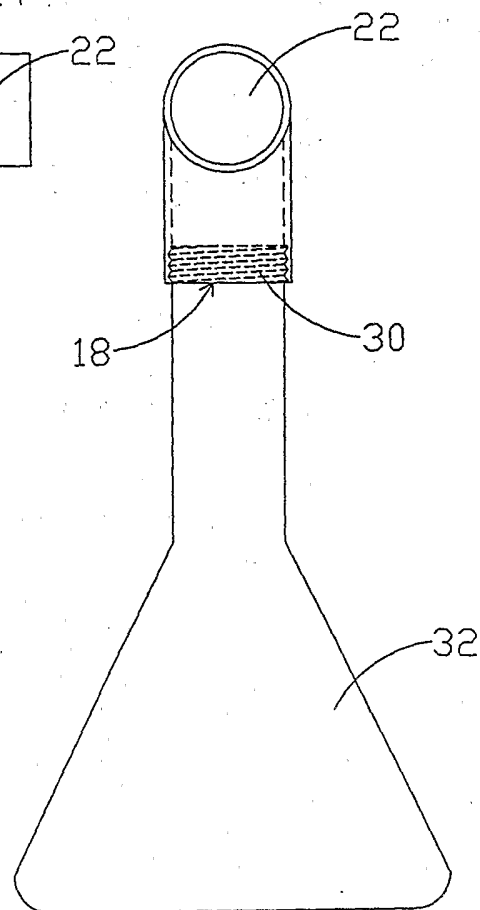

Figure 1c

Figure 2a

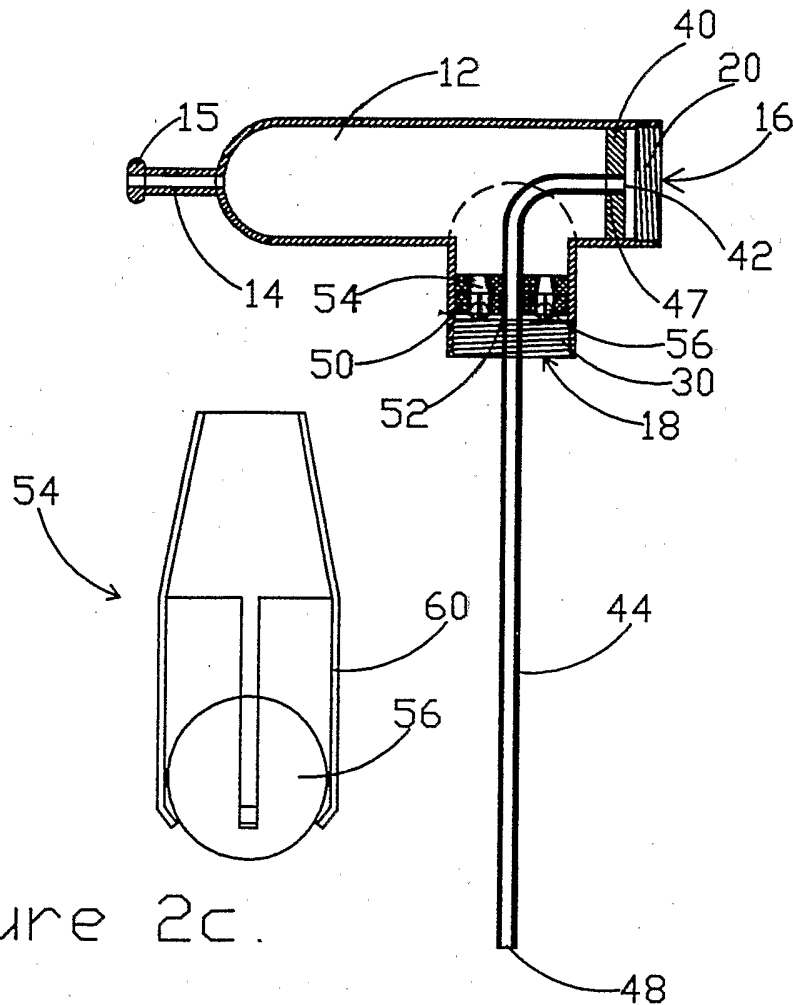

Figure 2c.

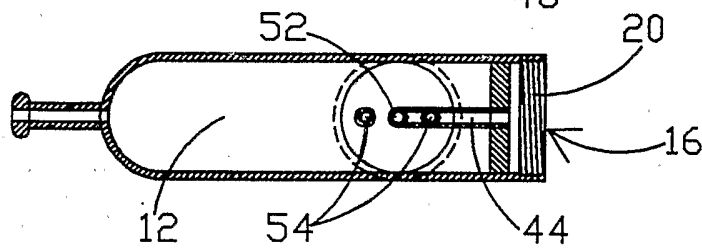

Figure 2b

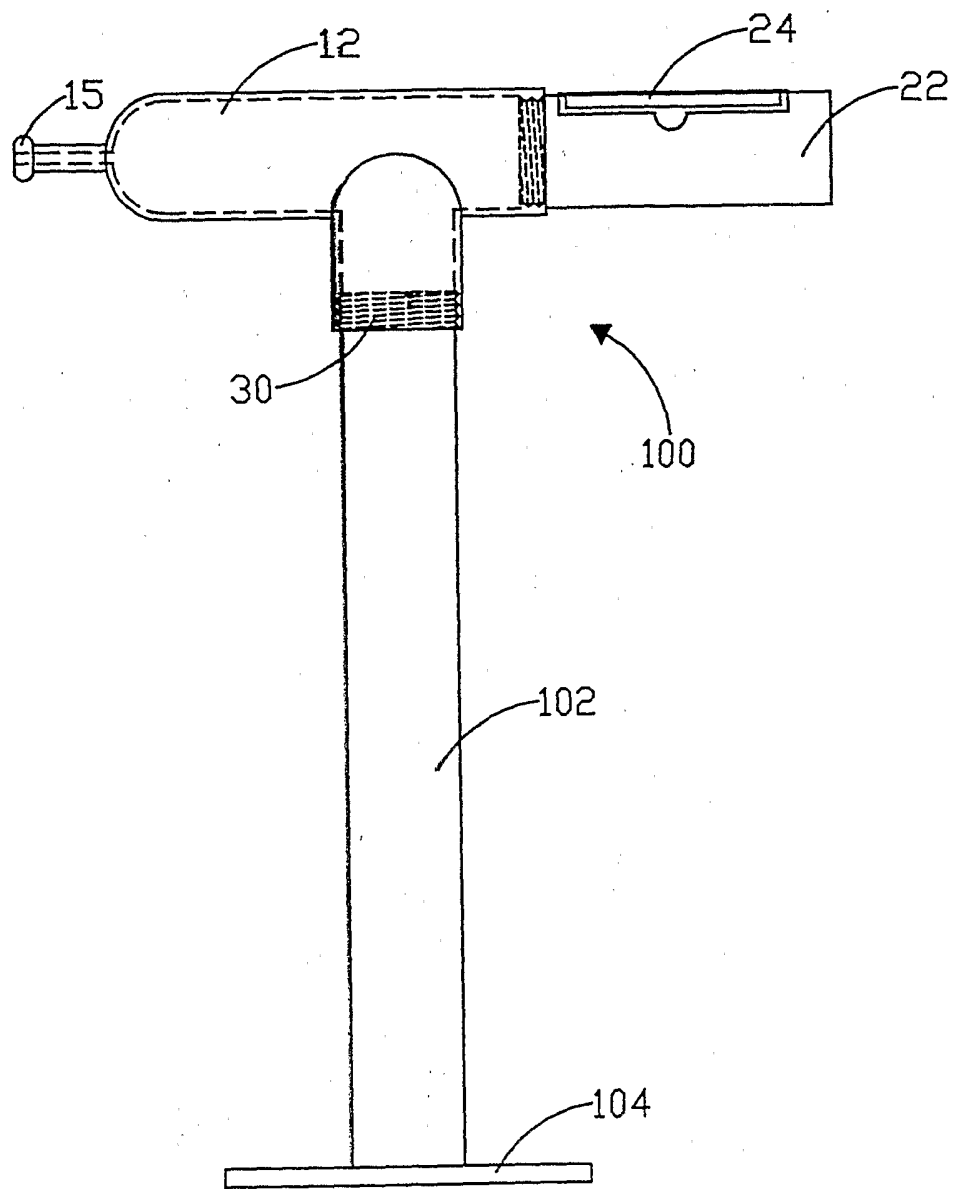

Figure 3

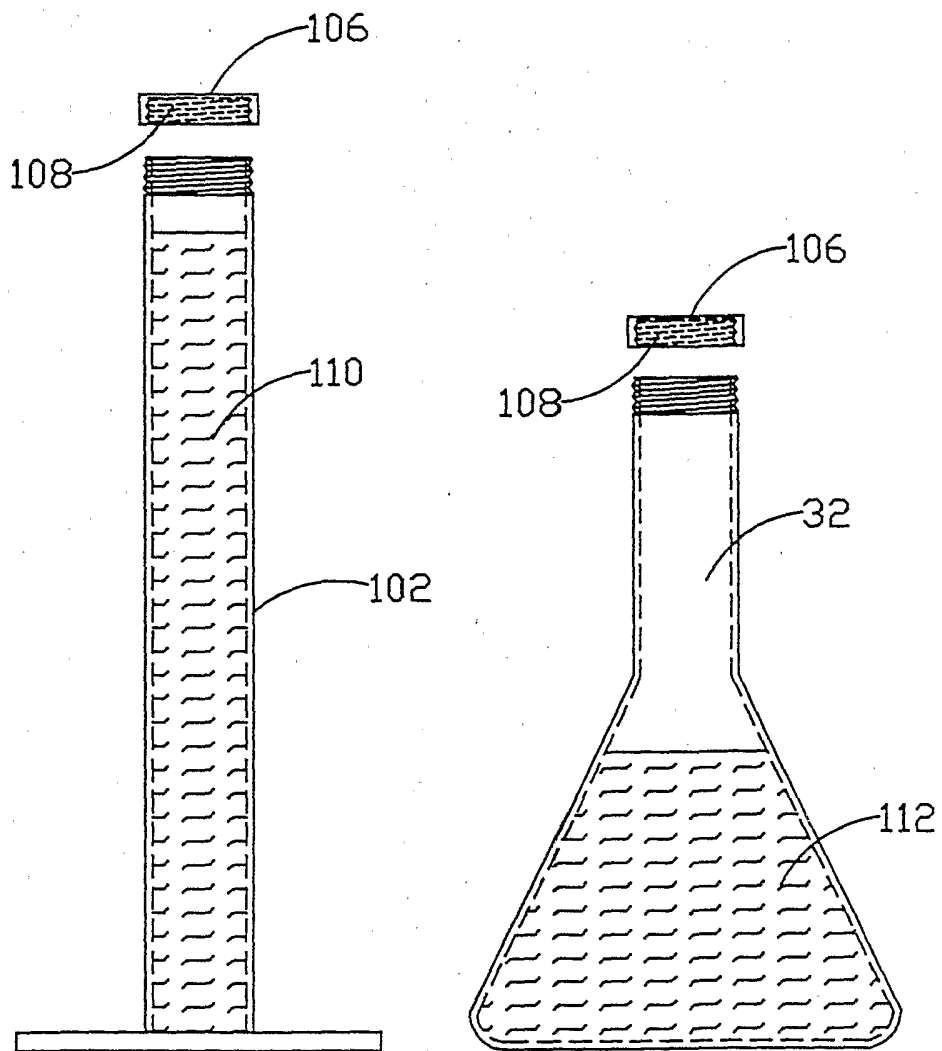

Figure 4

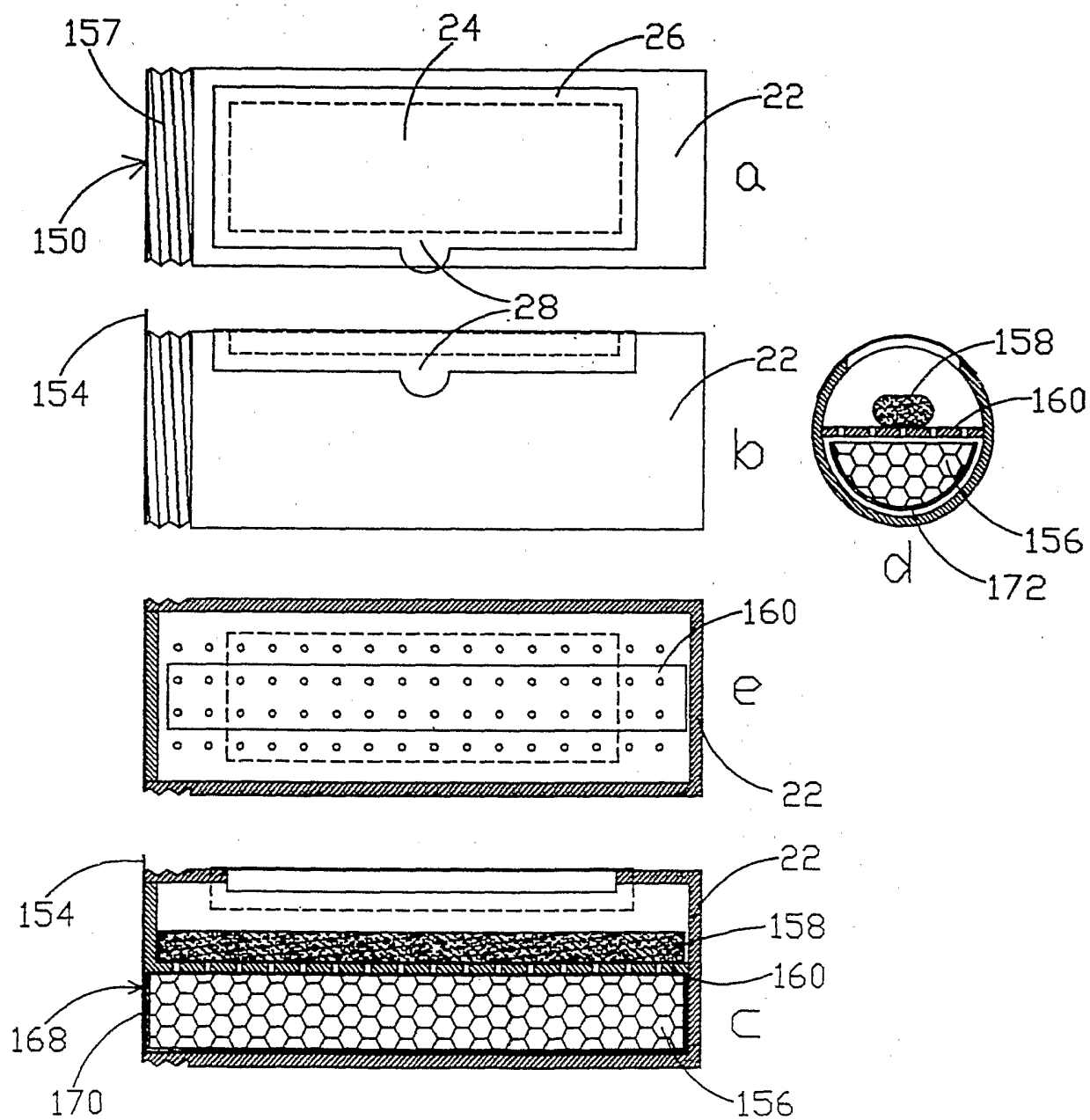

Figure 5

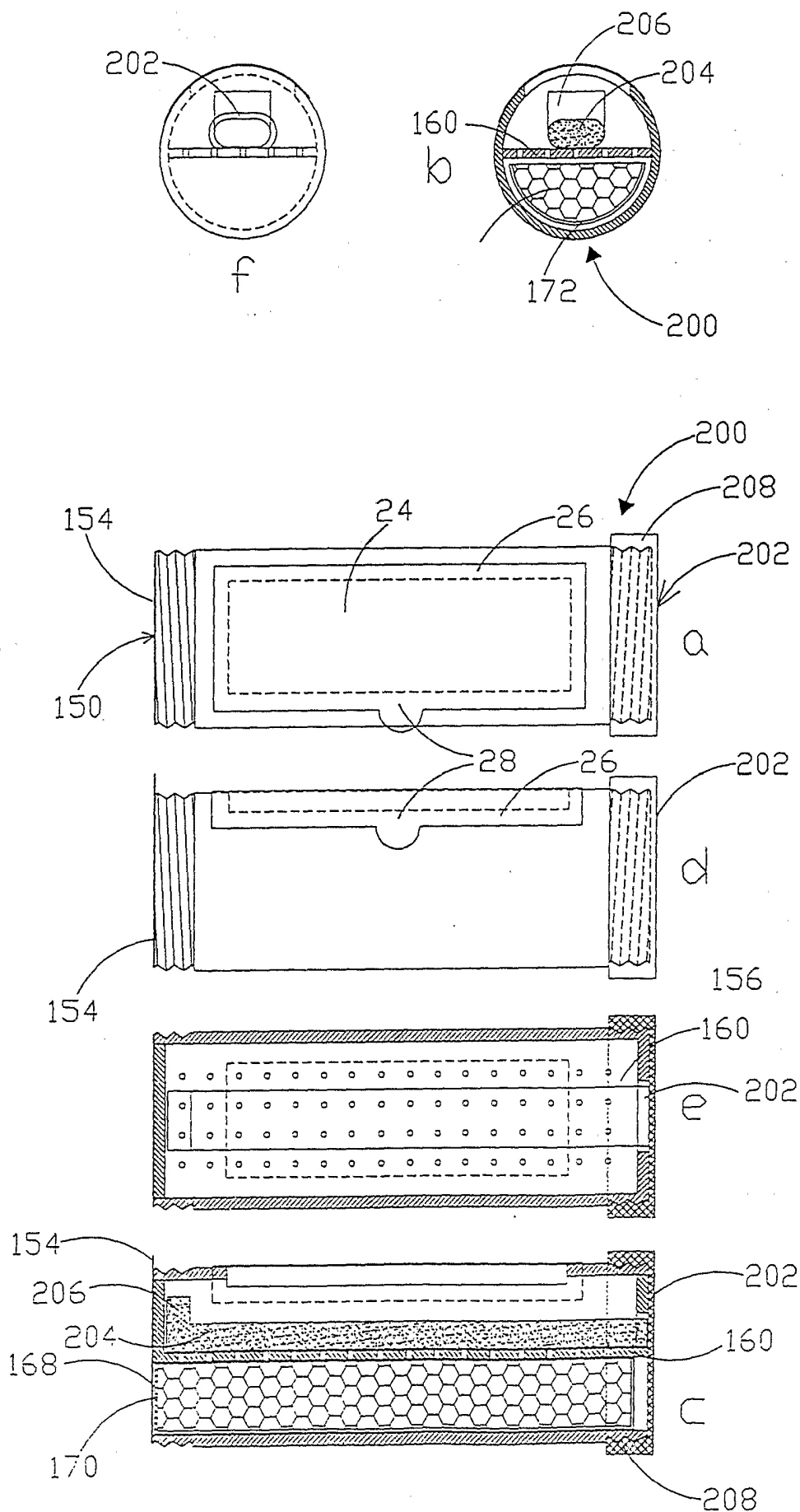

Figure 6

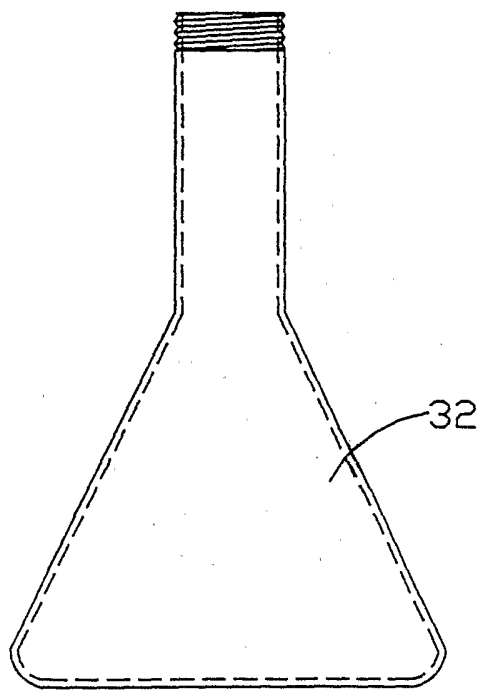
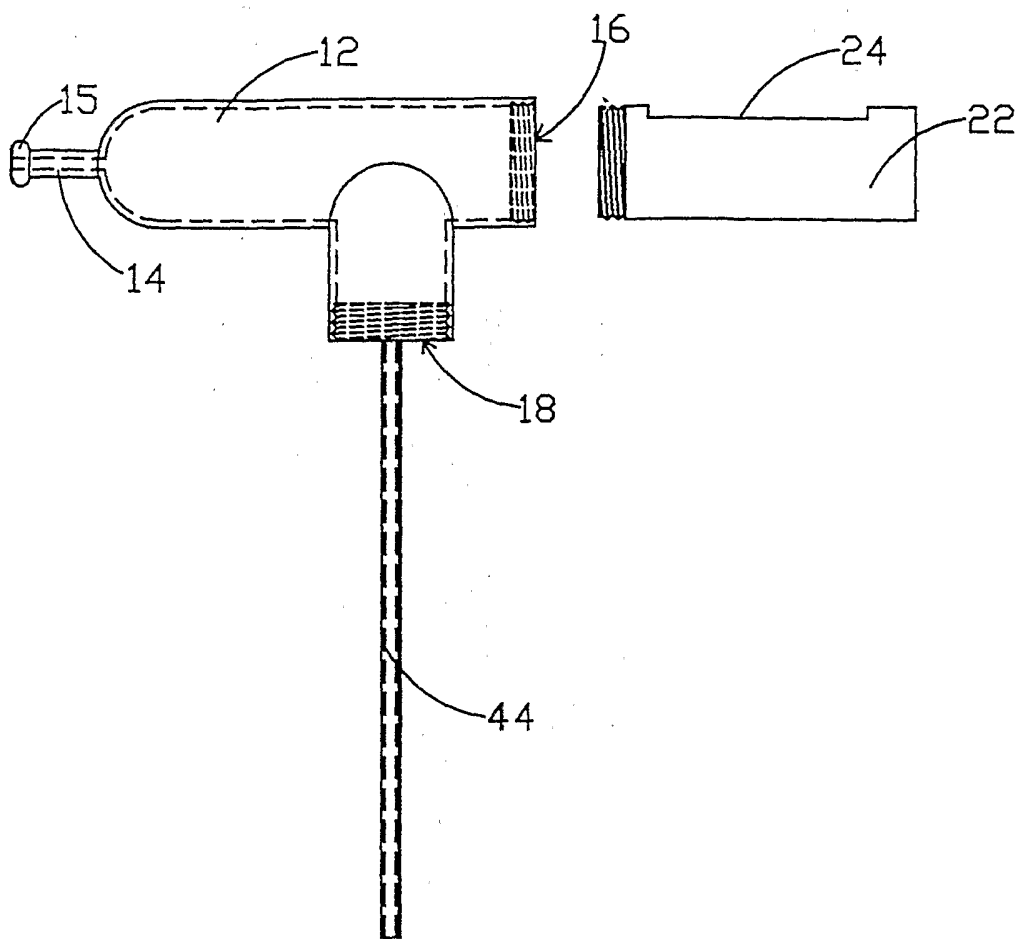

Figure 7

INTERNATIONAL SEARCH REPORT

International application No.

PCT/IL03/01121

A. CLASSIFICATION OF SUBJECT MATTER

IPC(7) : A24F 01/14
 US CL : 131/173,329

According to International Patent Classification (IPC) or to both national classification and IPC

B. FIELDS SEARCHED

Minimum documentation searched (classification system followed by classification symbols)
 U.S. : 131/173,329

Documentation searched other than minimum documentation to the extent that such documents are included in the fields searched

Electronic data base consulted during the international search (name of data base and, where practicable, search terms used)

C. DOCUMENTS CONSIDERED TO BE RELEVANT

Category *	Citation of document, with indication, where appropriate, of the relevant passages	Relevant to claim No.
Y --- A	US 4,638,815 A (YOSHIOKA) 27 January 1987 (27.01.1987), see columns 2 and 3; and see figs)	1,12-16,18-22 ----- 2-11,17,23-32
A	US 55,321 A (MASSON) 05 June 1866 (05.06.1866), see entire document.	1-32

Further documents are listed in the continuation of Box C.

See patent family annex.

* Special categories of cited documents:

"A" document defining the general state of the art which is not considered to be of particular relevance	"T" later document published after the international filing date or priority date and not in conflict with the application but cited to understand the principle or theory underlying the invention
"E" earlier application or patent published on or after the international filing date	"X" document of particular relevance; the claimed invention cannot be considered novel or cannot be considered to involve an inventive step when the document is taken alone
"L" document which may throw doubts on priority claim(s) or which is cited to establish the publication date of another citation or other special reason (as specified)	"Y" document of particular relevance; the claimed invention cannot be considered to involve an inventive step when the document is combined with one or more other such documents, such combination being obvious to a person skilled in the art
"O" document referring to an oral disclosure, use, exhibition or other means	"&" document member of the same patent family
"P" document published prior to the international filing date but later than the priority date claimed	

Date of the actual completion of the international search

01 May 2004 (01.05.2004)

Date of mailing of the international search report

17 MAY 2004

Name and mailing address of the ISA/US

Mail Stop PCT, Attn: ISA/US
 Commissioner for Patents
 P.O. Box 1450
 Alexandria, Virginia 22313-1450

Facsimile No. (703) 305-3230

Authorized officer

Dionne A. Walls

Telephone No. (571) 272-1700

