

(19) World Intellectual Property
Organization
International Bureau



(43) International Publication Date
24 June 2004 (24.06.2004)

PCT

(10) International Publication Number
WO 2004/053933 A2

- (51) International Patent Classification⁷: **H01L**
- (21) International Application Number: PCT/US2003/038214
- (22) International Filing Date: 3 December 2003 (03.12.2003)
- (25) Filing Language: English
- (26) Publication Language: English
- (30) Priority Data:
60/431,523 6 December 2002 (06.12.2002) US
- (71) Applicant: **CREE, INC.** [US/US]; 4600 Silicon Drive, Durham, NC 27703 (US).
- (72) Inventor: **LOH, Ban, P.**; 8 Trescott Drive, Durham, NC 27703 (US).
- (74) Agent: **CHUNG, D., James.**; Silicon Edge Law Group LLP, 6601 Koll Center Parkway, Suite 245, Pleasanton, CA 94566 (US).
- (81) Designated States (*national*): AE, AG, AL, AM, AT, AU, AZ, BA, BB, BG, BR, BY, BZ, CA, CH, CN, CO, CR, CU, CZ, DE, DK, DM, DZ, EC, EE, ES, FI, GB, GD, GE, GH, GM, HR, HU, ID, IL, IN, IS, JP, KE, KG, KP, KR, KZ, LC, LK, LR, LS, LT, LU, LV, MA, MD, MG, MK, MN, MW, MX, MZ, NI, NO, NZ, OM, PG, PH, PL, PT, RO, RU, SC, SD, SE, SG, SK, SL, SY, TJ, TM, TN, TR, TT, TZ, UA, UG, UZ, VC, VN, YU, ZA, ZM, ZW.
- (84) Designated States (*regional*): ARIPO patent (BW, GH, GM, KE, LS, MW, MZ, SD, SL, SZ, TZ, UG, ZM, ZW), Eurasian patent (AM, AZ, BY, KG, KZ, MD, RU, TJ, TM), European patent (AT, BE, BG, CH, CY, CZ, DE, DK, EE, ES, FI, FR, GB, GR, HU, IE, IT, LU, MC, NL, PT, RO, SE, SI, SK, TR), OAPI patent (BF, BJ, CF, CG, CI, CM, GA, GN, GQ, GW, ML, MR, NE, SN, TD, TG).
- Declarations under Rule 4.17:**
— *as to applicant's entitlement to apply for and be granted a patent (Rule 4.17(ii)) for all designations*

[Continued on next page]

(54) Title: COMPOSITE LEADFRAME LED PACKAGE AND METHOD OF MAKING THE SAME

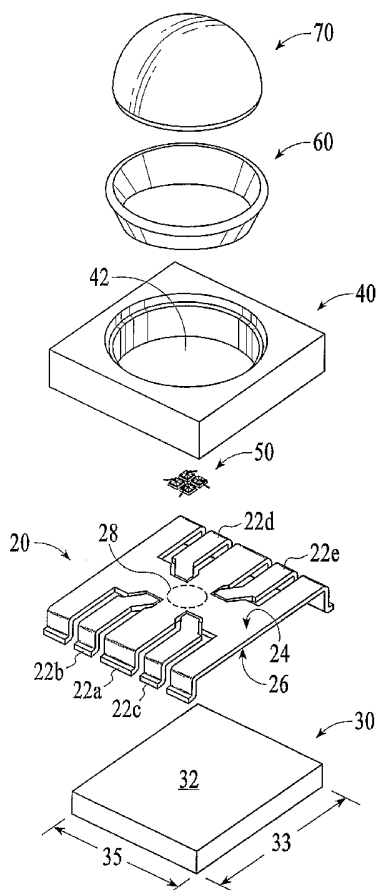

(57) Abstract: Light emitting die package (10) is disclosed. The die package (10) includes a leadframe (20), a bottom heatsink (30), a top heatsink (40), a reflector (60) and a lens (70). The top and bottom heatsinks (40 and 30) are thermally coupled but electrically insulated from the leadframe (20). The leadframe (20) includes a plurality of leads (22) and defines a mounting pad (28) for mounting LEDs (50). The top heatsink (40) defines an opening (42) over the mounting pad (42). The reflector (60) is coupled to the top heatsink (40) at the opening (42). The lens (70) is placed over the opening (42) defining an enclosed cavity (44) over the mounting pad (28). At least one light emitting device (LED) (50) is mounted on the mounting pad (28) within the cavity (44). Encapsulant optically couples the LED (50) to its surrounding surfaces to maximize its optical performance. When energized, the LED (50) generates light and heat. The light is reflected by the reflector (60) and operated on by the lens (70). The heat is dissipated by the top and the bottom heatsinks (40 and 30).

WO 2004/053933 A2



— *as to the applicant's entitlement to claim the priority of the earlier application (Rule 4.17(iii)) for all designations*

For two-letter codes and other abbreviations, refer to the "Guidance Notes on Codes and Abbreviations" appearing at the beginning of each regular issue of the PCT Gazette.

Published:

— *without international search report and to be republished upon receipt of that report*

COMPOSITE LEADFRAME LED PACKAGE AND METHOD OF MAKING THE SAME**INVENTOR**

Ban P. Loh

PRIORITY

[0001] This application claims the benefit of the filing date of U.S. Provisional Patent Application No. 60/431,523 filed December 6, 2002 with the United States of America Patent and Trademark Office entitled "Leadframe based LED or semiconductor package with improved heat spreading".

BACKGROUND

[0002] The present invention relates to the field of packaging semiconductor devices, and more particularly to packaging light emitting diodes.

[0003] Light emitting devices (LEDs) such as light emitting diodes are often packaged within leadframe packages. A leadframe package typically includes an LED connected to thin metal leads where the LED and most of the leads are completely encapsulated within a plastic body. A part of the plastic body defines a lens. A portion of the leads connected to the LED extends outside the plastic body. The metal leads of the leadframe package serve as the conduit to supply the LED with electrical power and, at the same time, may act to draw heat away from the LED. Heat is generated by the LED when power is applied to the LED to produce light. The portion of the leads that extend out from the package body connects to circuits external to the leadframe package.

[0004] Some of the heat generated by the LED is dissipated by the plastic package body; however, most of the heat is drawn away from the LED via the metal components of the

package. The metal leads are typically very thin and have a small cross section. For this reason, capacity of the metal leads to remove heat from the LED is limited. This limits the amount of power that can be sent to the LED. This, in turn, limits the amount of light that can be generated by the LED.

[0005] To increase the capacity of an LED package to dissipate heat, various designs are used in the industry; however, each of these designs results in LED packages with limited heat dissipation capacities while increasing the complexity and the costs of manufacturing the LED packages. For example, in one approach, LED packages are designed to include the LED within a cavity of a heatsink slug. Then, the heatsink slug is surrounded by a plastic body except for its bottom surface. For example, some LUXEON™ LED packages by Lumileds Lighting, LLC embodies such a design. Here, the heatsink slug increases the capacity of the LED package to dissipate heat; however, LED packages of this design are relatively difficult and costly to manufacture. Further, the heat dissipation is limited because of its limited exposed surface (the bottom surface only).

[0006] In another LED package design, the leads of the leadframe are extended (in various shapes and configurations) beyond the immediate edge of the LED package body. This increases the surface area of the portions of the leads exposed to the surrounding air. The increased exposed surface area of the extended leads increases the capacity of the LED package to dissipate heat; however, the extended leads increase the size of the LED package requiring relatively large area on a circuit board. Circuit board area is a scarce and costly factor in many applications.

[0007] Another undesirable aspect of the current leadframe package designs relates to problems associated with thermal expansion of the package. When heat is generated, the LED package experiences thermal expansion. Each of the parts of the LED package has a different coefficient of thermal expansion (CTE). For example, the CTE of the LED, the CTE of the package body, the CTE of the leads, and the CTE of lens are different from each other. For this reason, when heated, each of these parts experience different degrees of thermal expansion resulting in mechanical stresses between the parts of the package thereby adversely affecting its reliability.

[0008] Consequently, there remains a need for an improved LED package that overcomes or alleviates one or more of the shortcomings of the prior art packages.

SUMMARY

[0009] The need is met by the present invention. In a first embodiment of the present invention, a light emitting die package includes a leadframe, a bottom heatsink and a top heatsink. The leadframe has a top side and a bottom side and includes a plurality of leads. A portion of the leadframe defines a mounting pad. The bottom heatsink is coupled to the bottom side of the leadframe. The top heatsink is coupled to the top side of the leadframe. The top heatsink defines an opening which generally surrounds the mounting pad.

[0010] In a second embodiment of the present invention, a light emitting die package includes a leadframe, a bottom heatsink and a top heatsink. The leadframe has a top side and a bottom side and includes a plurality of leads. The bottom heatsink is thermally coupled to the bottom side of the leadframe under the mounting pad. The bottom

heatsink is electrically insulated from the leadframe. The top heatsink is thermally coupled to the top side of the leadframe and defines an opening which generally surrounds the mounting pad. The top heatsink is electrically insulated from the leadframe and is coupled to a reflector that also surround the mounting pad. At least one light emitting device (LED) is mounted on the mounting pad, the LED adapted to generate light when energized. A lens is coupled to the top heatsink over the opening. The lens is adapted to operate on the light generated by the LED. The lens covers the opening thereby defining an enclosed cavity.

[0011] In a third embodiment of the present invention, a method of manufacturing a light emitting die package is disclosed. First, a leadframe die is fabricated. The leadframe die includes a plurality of leads and die frame, each lead and the die frame having a top side and a bottom side. Then, a top heatsink is coupled over the leadframe die, the top heatsink defining an opening. Next, a bottom heatsink is coupled under the leadframe die. Finally, the leadframe die is stamped to cut-away the die frame.

[0012] Other aspects and advantages of the present invention will become apparent from the following detailed description, taken in conjunction with the accompanying drawings, illustrating by way of example the principles of the invention.

BRIEF DESCRIPTION OF THE DRAWINGS

[0013] Figures 1A and 1B are perspective views of a light emitting die package according to one embodiment of the present invention;

[0014] Figure 1C is a cutaway side view of the light emitting die package of Figure 1A cut along line A-A;

[0015] Figure 2 is an exploded perspective view of the semiconductor package of Figure 1A;

[0016] Figure 3 is a perspective view of a light emitting die package of Figure 1A during its manufacturing process.

DETAILED DESCRIPTION

[0017] The present invention will now be described with reference to the Figures 1 through 3, which illustrate various embodiments of the present invention. As illustrated in the Figures, the sizes of layers or regions are exaggerated for illustrative purposes and, thus, are provided to illustrate the general structures of the present invention. Furthermore, various aspects of the present invention are described with reference to a structure or a portion being formed on other structures, portions, or both. As will be appreciated by those of skill in the art, references to a structure being formed "on" or "above" another structure or portion contemplates that additional structure, portion, or both may intervene. References to a structure or a portion being formed "on" another structure or portion without an intervening structure or portion are described herein as being formed "directly on" the structure or portion. Furthermore, relative terms such as "on" or "above" are used herein to describe one structure's or portion's relationship to another structure or portion as illustrated in the Figures. It will be understood that relative terms such as "on" or "above" are intended to encompass different orientations of the device in addition to the orientation depicted in the Figures. For

example, if the device in the Figures is turned over, structure or portion described as "above" other structures or portions would now be oriented "below" the other structures or portions. Likewise, if the device in the Figures is rotated along an axis, structure or portion described as "above" other structures or portions would now be oriented "next to" or "left of" the other structures or portions. Like numbers refer to like elements throughout.

[0018] As shown in the figures for the purposes of illustration, embodiments of the present invention are exemplified by a light emitting die package including a leadframe with leads, a bottom heatsink, and a top heatsink with an opening. A light emitting device (LED) such as a light emitting diode is mounted on the leadframe within the opening. A lens covers the opening. In effect, the light emitting die package according to one embodiment of the present invention comprises a two part heat sink sandwiching a leadframe. Because both the bottom and the top heat sinks draw heat away from the LED, more power can be delivered to the LED, and the LED can produce more light. Furthermore, for the same reason, the light emitting die package of the present invention may not require a separate heat sink slugs or leads that extend away from the package. Accordingly, the LED die package of the present invention may be more compact, more reliable, and less costly to manufacture than the die packages of the prior art.

[0019] Figures 1A and 1B are perspective views of a light emitting die package 10 according to one embodiment of the present invention. Figure 1C is a cutaway side view of the light emitting die package 10 of Figure 1A cut along line A-A. Figure 2 is an exploded perspective view

of the semiconductor package 10 of Figures 1A and 1B. Referring to Figures 1A through 2, the semiconductor package 10 includes a leadframe 20, a bottom heatsink 30, and a top heatsink 40.

[0020] The leadframe 20 includes a plurality of leads. In the figures, for illustrative purposes only, leads 22a, 22b, 22c, 22d, and 22e are shown. For convenience, the leads 22a, 22b, 22c, 22d, and 22e are collectively referred to as leads 22 in this document. The leads 22a, 22b, 22c, 22d, and 22e are electrically isolated from each other. To avoid clutter, not all instances of the leads 22 are illustrated with a reference numeral in the Figures. The leadframe 20 includes a top side 24 and a bottom side 26. Further, a portion 28 of the leadframe 20 defines a mounting pad 28. The mounting pad 28 is a portion of the leadframe 20 (including a portion of the first lead 22a) where an LED assembly 50 is mounted. Typically the mounting pad 28 is generally located proximal to center of the top side 24 of the leadframe 20. In alternative embodiments of the present invention, the LED assembly 50 can be replaced by other semiconductor circuits or chips. The leadframe 20 is made of electrically conductive material and is generally thin. In one embodiment the leadframe 20 has thickness in order of thousandths or hundredths of inches, and for example, ranges from 0.005 inches to 0.010 inches.

[0021] The bottom heatsink 30 is coupled to the bottom side 26 of the leadframe 20 at least under the mounting pad 28. The bottom heatsink 30 is made of thermally conductive material and is thermally coupled to the bottom side 26 of the leadframe 20 but is electrically separated from the leadframe 20. The bottom heatsink 30 has a top surface 32 thermally coupled to but is

electrically separated from the leadframe 20, the electrical separation can be accomplished by using a dielectric layer between the leadframe 20 and the bottom heatsink 30, for example, adhesive filled with ceramic particles. The bottom heatsink 30 has a bottom surface 34 defining a bottom plane for the light emitting die package 10. The bottom surface 34 of the bottom heatsink 30 can include a metalized bottom as illustrated in Figure 1B. As illustrated, the leads 22 are bent toward the bottom plane, terminating proximal to the bottom plane.

[0022] The top heatsink 40 is coupled to the top side 24 of the leadframe 20. The top heatsink 40 defines an opening 42, the opening 42 generally surrounding the mounting pad 28. The top heatsink 40 is made of thermally conductive material and is thermally coupled to the top side 24 of the leadframe 20 but is electrically separated from the leadframe 20, the electrical separation can be accomplished by using a dielectric layer between the leadframe 20 and the bottom heatsink 40. The bottom heatsink 30 and the top heatsink 40 have generally similar lateral dimensions, or extents, and substantially overlap each other sandwiching the leadframe 20 between them. The top heatsink 40 and the bottom heatsink 30 are made with thermally conductive material such as, for example only, copper, aluminum, or ceramics material.

[0023] The light emitting die package 10 includes the LED assembly 50 including at least one light emitting device (LED) mounted on the mounting pad. In Figure 2, the LED assembly 50 is illustrated as having four light emitting diodes. The LEDs are adapted to generate light when energized.

[0024] The light emitting die package 10 includes a reflector 60 coupled to the top heatsink 40, the reflector 60 surrounding the mounting pad 28. In an alternative embodiment, the reflector 60 is not a separate component but is integrated with and is a portion of the top heatsink 40. The reflector 60 is adapted to reflect light from the LED assembly 50 toward a lens 70.

[0025] The light emitting die package 10 includes the lens 70 coupled to the top heatsink 40, the lens 70 coupled generally over the opening 42, the mounting pad 28, and over the reflector 60. When the lens 70 is placed over the opening 42, an enclosed cavity 44 is defined by the leadframe 20, the opening 42 of the top heatsink 40, and the lens 70. The lens 70 operates on the light generated by the LED assembly 50 by, for example, reflecting, directing, focusing, and alter wavelength. For example, a bottom surface 72 of the lens 70 can be coated with calcium carbonate to diffuse the light. Alternately, the bottom surface 72 of the lens 70 can be coated with phosphors to alter wavelengths of light from the LED assembly 50.

[0026] The enclosed cavity 44 is filled by clear encapsulant such as Silicone. The encapsulant affixes the LED assembly 50 to the mounting pad 28. The enclosed cavity 44 need not be completely filled with the encapsulant. In fact, partially filling the cavity 44 with encapsulant while leaving gaps within the cavity 44 allows the encapsulant to expand (when heat is generated by the LED assembly 50) without separating the lens 70 from the top heatsink 40.

[0027] The method of manufacturing the light emitting die package 10 of Figures 1A through 2 can be discussed using

Figure 3. Figure 3 illustrates the light emitting die package 10 of Figure 1A before it is manufactured. To manufacture the light emitting die package 10 of Figure, a leadframe die 80 is fabricated. For illustratively purposes, in Figure 2, the leadframe die 80 is fabricated for manufacturing of two light emitting die packages. In fact, a leadframe die can be fabricated to manufacture multiple light emitting die packages simultaneously. The leadframe die 80 includes a plurality of leads, for example, the leads 22a, 22b, 22c, 22d, and 22e (collectively, "leads 22") and a die frame 82 surrounding the leads 22. The leadframe die has a top side 24 (that is the same side as the top side 24 of leadframe 20 of Figure 2) and a bottom side 26 (that is the same side as the bottom side 26 of leadframe 20 of Figure 2). The leadframe die 80 is fabricated by stamping a sheet of die material such as metal. The thickness of the die material may vary greatly depending on the desired application, for example, the thickness may be in the order of fractions of millimeters (mm), for example, ranging from 0.13 mm to 0.25 mm. Alternately, the leadframe die 80 can be fabricated using etching processes.

[0028] Referring to Figures 2 and 3, the top heatsink 40 is coupled to the leadframe die 80. As already described, the top heatsink 40 defined the opening 42. The bottom heatsink 30 is coupled to the bottom side of the leadframe die 80. The bottom heatsink 30 has a top surface 32 thermally coupled to but is electrically separated from the leadframe die 80. As illustrated in Figure 1B, the bottom heatsink 30 has a metalized bottom surface 34 defining a bottom plane for the light emitting die package 30. Dielectric but thermally conductive

adhesive layer 38 of Figure 3 may be used to separate the bottom heatsink 30 from the leadframe 20.

[0029] The top heatsink 40 and the bottom heatsink 30 have similar lateral extents and substantially overlap each other. For example, the lateral extents 33 and 35 of the bottom heatsink 30 may vary widely depending on the implementation, for example only, the lateral extents 33 and 35 may be in the order of mm or centimeters (cm), and may range from, for example, seven mm to 20 mm. The bottom heatsink 30 and the top heatsink 40 may have thicknesses in the order of mm or cm, and may range from, for example, 1.5 mm to three mm. These measurements may vary greatly depending on various desired characteristics and applications.

[0030] Referring to Figures 2 and 3, the method of manufacturing the light emitting die package 10 is further discussed. The LED assembly 50 including at least one light emitting device (LED) such as a light emitting diode is mounted on at least one lead, such as the lead 22a, within the opening 42. Then, the reflector 60 and the lens 70 are attached on the top heatsink 40, the lens 70 covering the opening 42. The reflector 60 surrounds the opening 42. The reflector 60 may be integrated with the top heatsink 40 in which case there is no need for a separate step of coupling the reflector 60 with the top heatsink 40.

[0031] Finally, the leadframe die 80 is stamped to cut away the die frame 82. During the stamping, the leads 22 are bent towards the bottom plane as illustrated in Figures 1A through 2.

[0032] From the foregoing, it will be apparent that the present invention is novel and offers advantages over the current art. Although specific embodiments of the

invention are described and illustrated above, the invention is not to be limited to the specific forms or arrangements of parts so described and illustrated. For example, differing configurations, sizes, or materials may be used to practice the present invention. The invention is limited by the claims that follow.

WHAT IS CLAIMED IS:

1. A light emitting die package (10) comprising:
 - a leadframe (20) including a plurality of leads (22), said leadframe (20) having top side (24) and bottom side (26), and a portion of said leadframe defining a mounting pad (28);
 - a bottom heatsink (30) coupled to the bottom side (26) of said leadframe (20); and
 - a top heatsink (40) coupled to the top side (24) of said leadframe (20), said top heatsink (40) defining an opening (42), the opening (42) generally surrounding the mounting pad (28).
2. The light emitting die package (10) recited in claim 1 wherein said top heatsink (40) is electrically separated from said leadframe (20).
3. The light emitting die package (10) recited in claim 1 wherein said top heatsink (40) and said bottom heatsink (30) have similar lateral extents and substantially overlap each other.
4. The light emitting die package (10) recited in claim 1 wherein said bottom heatsink (30) has a top surface (32) thermally coupled to but is electrically separated from said leadframe (20), and said bottom heatsink (30) has a metalized bottom surface (34) defining a bottom plane for the light emitting die package (10).
5. The light emitting die package (10) recited in claim 4 wherein the leads (22) are bent toward the bottom plane, and the leads (22) terminate proximal to the bottom plane.

6. The light emitting die package (10) recited in claim 1 further comprising at least one light emitting device (LED) (50) mounted on the mounting pad (28).
7. The light emitting die package (10) recited in claim 1 further comprising a reflector (60) coupled to said top heatsink (40), said reflector (60) surrounding the mounting pad (28).
8. The light emitting die package (10) recited in claim 1 further comprising a lens (70) coupled to said top heatsink (40) over the mounting pad (28).
9. A light emitting die package (10) comprising:
 - a leadframe (20) including a plurality of leads (22), said leadframe (20) having top side (24) and a bottom side (26); and a portion of said leadframe defining a mounting pad (28);
 - a bottom heatsink (30) thermally coupled to the bottom side (26) of said leadframe (20) under the mounting pad (28), said bottom heatsink (30) electrically insulated from said leadframe (20);
 - a top heatsink (40) thermally coupled to the top side (24) of said leadframe (20), said top heatsink (40) defining an opening (42), the opening (42) generally surrounding the mounting pad (28), said top heatsink (40) electrically insulated from said leadframe (20), and said top heatsink (40) coupled to a reflector (60) also surround the mounting pad (28);
 - at least one light emitting device (LED) (50) mounted on the mounting pad (28), the LED (50) adapted to generate light when energized; and

a lens (70) coupled to said top heatsink (40) over the opening (42), said lens (70) adapted to operate on the light generated by the LED (50), the lens (70), covering the opening (42) thereby defining an enclosed cavity (44).

10. The light emitting die package (10) recited in claim 9 wherein said bottom heatsink (30) has a metalized bottom surface (34) defining a bottom plane for the light emitting die package (10).
11. The light emitting die package (10) recited in claim 9 wherein the enclosed cavity (44) is at least partially filled with encapsulant.
12. A method of manufacturing a light emitting die package (10), the method comprising:
 - fabricating a leadframe die (80), the leadframe die (80) including a plurality of leads (22) and die frame (82), each lead (22) and the die frame (82) having a top side (24) and a bottom side (26);
 - coupling a top heatsink (40) over the leadframe die (80), the top heatsink (40) defining an opening (42);
 - coupling a bottom heatsink (30) under the leadframe die (80); and
 - stamping the leadframe die (80) to cut-away the die frame (82).
13. The method recited in claim 12 wherein the leadframe die (80) is fabricated by stamping a sheet of die material.
14. The method recited in claim 12 wherein the leadframe die (80) is fabricated by etching process.

15. The method recited in claim 12 further comprising mounting at least one light emitting device (LED) (50) on at least one lead (22), the LED (50) mounted in the opening (42).
16. The method recited in claim 12 further comprising attaching a lens (70) on the top heatsink (40), the lens (70) covering the opening (42).
17. The method recited in claim 12 wherein the bottom heatsink (30) has a top surface (32) thermally coupled to but is electrically separated from the leadframe die (80), and the bottom heatsink (30) has a metalized bottom surface (34) defining a bottom plane for the light emitting die package (10).
18. The method recited in claim 17 further comprising bending the leads (22) toward the bottom plane.
19. The method recited in claim 14 further comprising coupling a reflector (60) on the top heatsink (40), said reflector (60) surrounding the opening (42).
20. The method recited in claim 14 wherein the top heatsink (40) includes an integrated reflector.

1/4

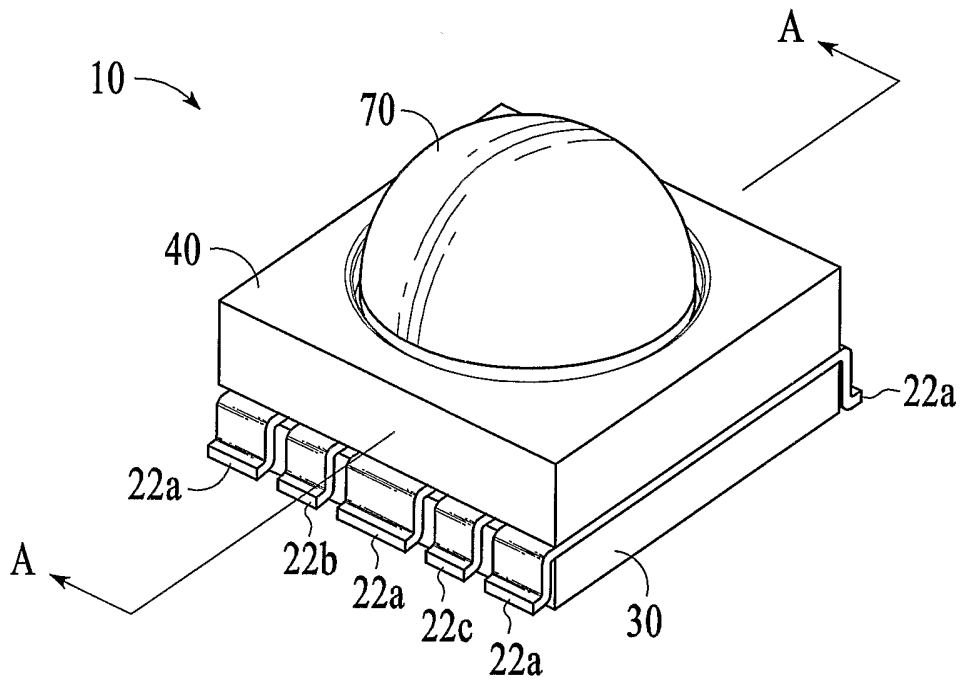

FIG. 1A

2/4

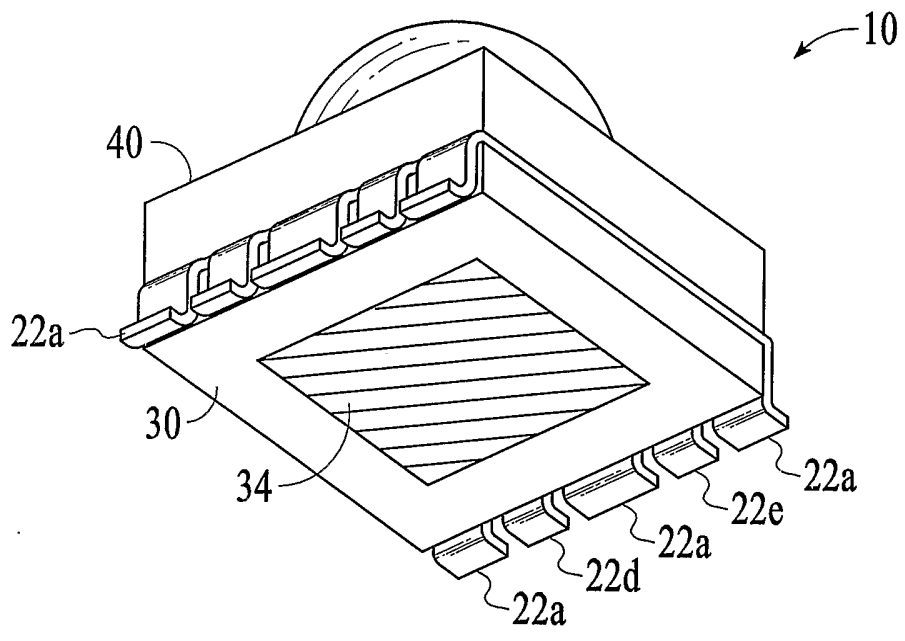

FIG. 1B

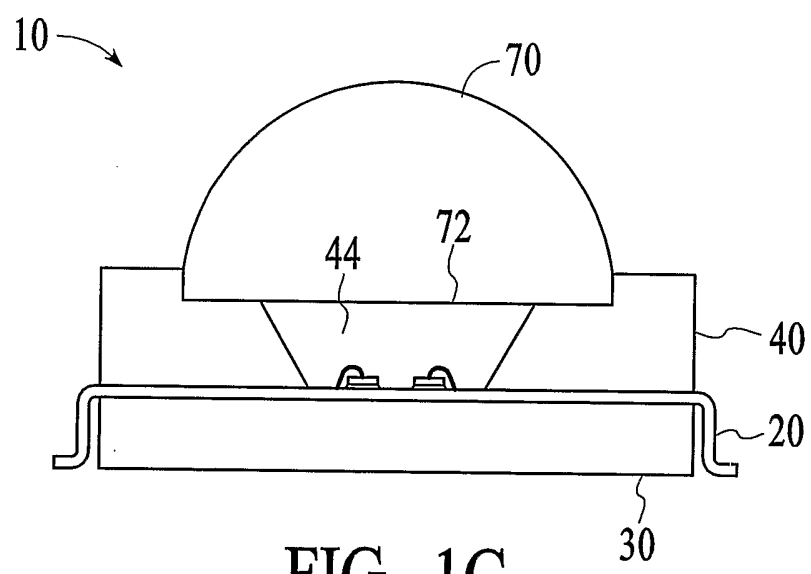
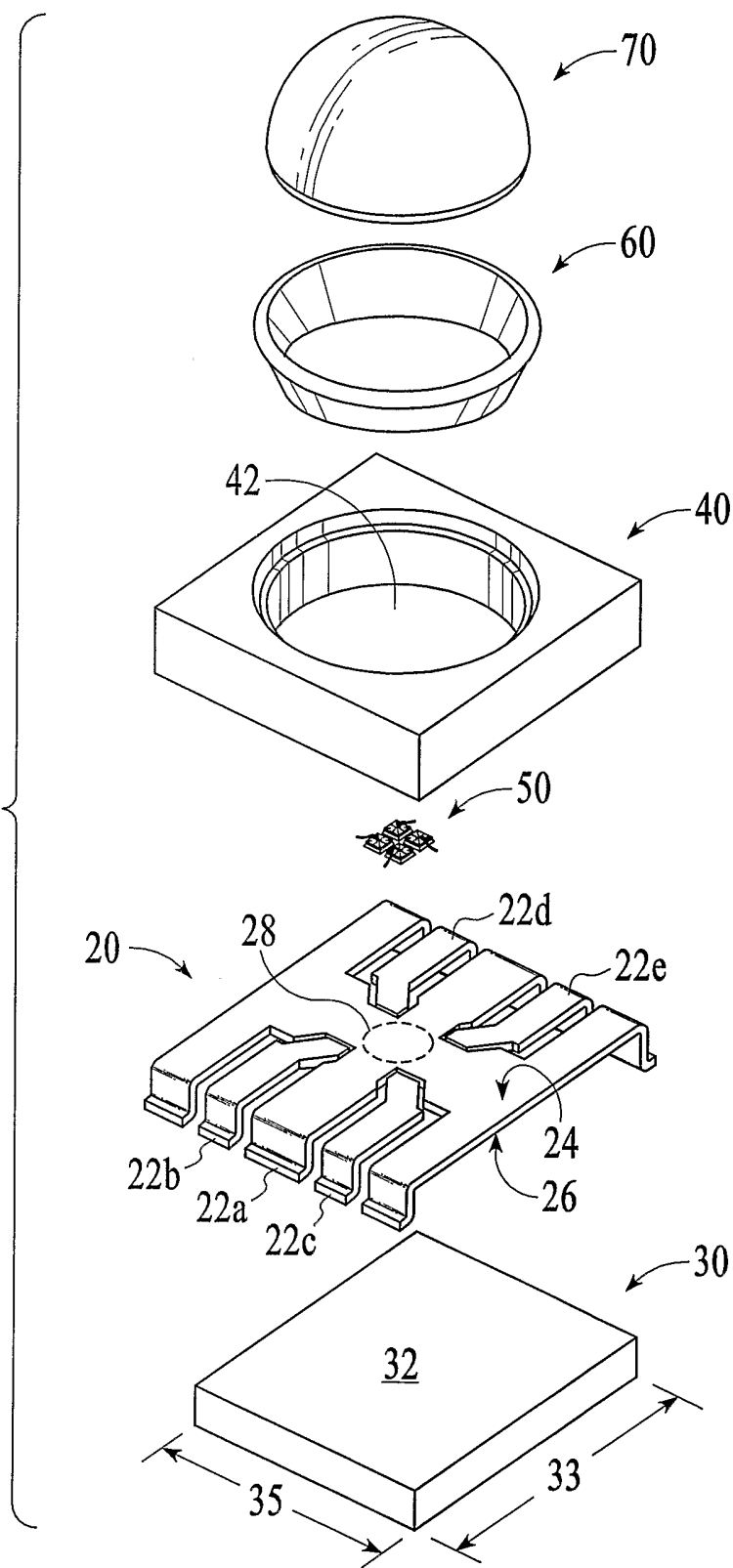

FIG. 1C

3/4

FIG. 2



4/4

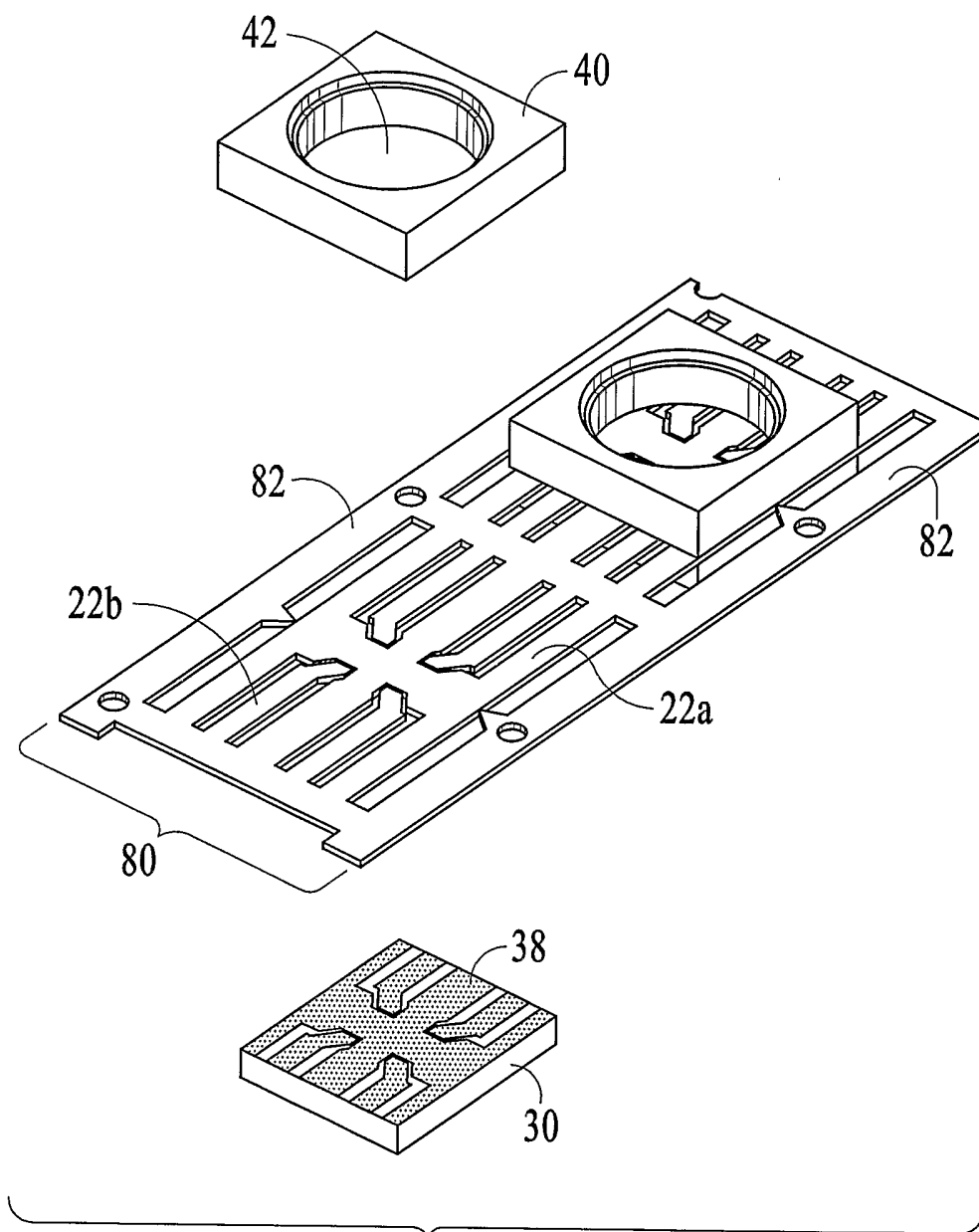

FIG. 3