

(19) World Intellectual Property Organization
International Bureau



(43) International Publication Date
17 December 2009 (17.12.2009)

(10) International Publication Number
WO 2009/152149 A4

- (51) International Patent Classification:
B08B 3/00 (2006.01) *A47L 11/34* (2006.01)
B08B 3/02 (2006.01) *A61L 2/07* (2006.01)
- (21) International Application Number: PCT/US2009/046743
- (22) International Filing Date: 9 June 2009 (09.06.2009)
- (25) Filing Language: English
- (26) Publication Language: English
- (30) Priority Data: 61/060,407 10 June 2008 (10.06.2008) US
- (71) Applicant (for all designated States except US): **TEN-NANT COMPANY** [US/US]; 701 North Lilac Drive, #29, P.o. Box 1452, Minneapolis, MN 55440 (US).
- (72) Inventor; and
(75) Inventor/Applicant (for US only): **FIELD, Bruce, F.** [US/US]; 4700 Circle Down, Golden Valley, MN 55416 (US).
- (74) Agents: **MORRISON, Brian R.** et al.; Westman, Champlin & Kelly, P.A., 900 Second Avenue South, Suite 1400, Minneapolis, MN 55402-3319 (US).
- (81) Designated States (unless otherwise indicated, for every kind of national protection available): AE, AG, AL, AM, AO, AT, AU, AZ, BA, BB, BG, BH, BR, BW, BY, BZ, CA, CH, CL, CN, CO, CR, CU, CZ, DE, DK, DM, DO,

[Continued on next page]

(54) Title: STEAM CLEANER USING ELECTROLYZED LIQUID AND METHOD THEREFOR

(57) Abstract: An apparatus (10) and method are provided for generating an electrochemically-activated vapor, wherein a liquid is electrochemically activated in an electrolysis cell.

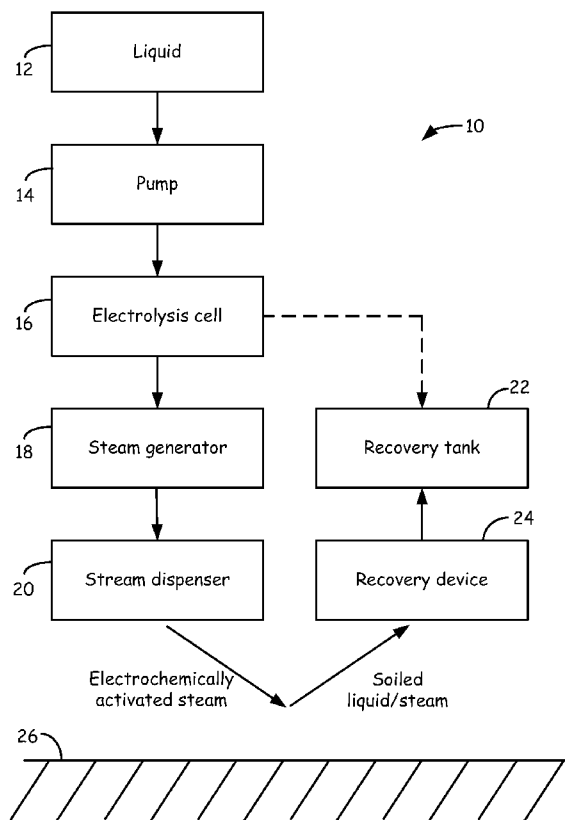

FIG. 1



WO 2009/152149 A4

DZ, EC, EE, EG, ES, FI, GB, GD, GE, GH, GM, GT, HN, HR, HU, ID, IL, IN, IS, JP, KE, KG, KM, KN, KP, KR, KZ, LA, LC, LK, LR, LS, LT, LU, LY, MA, MD, ME, MG, MK, MN, MW, MX, MY, MZ, NA, NG, NI, NO, NZ, OM, PE, PG, PH, PL, PT, RO, RS, RU, SC, SD, SE, SG, SK, SL, SM, ST, SV, SY, TJ, TM, TN, TR, TT, TZ, UA, UG, US, UZ, VC, VN, ZA, ZM, ZW.

MC, MK, MT, NL, NO, PL, PT, RO, SE, SI, SK, TR), OAPI (BF, BJ, CF, CG, CI, CM, GA, GN, GQ, GW, ML, MR, NE, SN, TD, TG).

Published:

- with international search report (Art. 21(3))
- with amended claims and statement (Art. 19(1))

(84) Designated States (unless otherwise indicated, for every kind of regional protection available): ARIPO (BW, GH, GM, KE, LS, MW, MZ, NA, SD, SL, SZ, TZ, UG, ZM, ZW), Eurasian (AM, AZ, BY, KG, KZ, MD, RU, TJ, TM), European (AT, BE, BG, CH, CY, CZ, DE, DK, EE, ES, FI, FR, GB, GR, HR, HU, IE, IS, IT, LT, LU, LV,

(88) Date of publication of the international search report:
4 February 2010

Date of publication of the amended claims and statement: 25 March 2010

AMENDED CLAIMS

received by the International Bureau on 01 February 2010 (01.02.10)

CLAIMS:

1. A steam cleaning apparatus comprising:
an electrolysis cell configured to electrochemically activate a liquid into an anolyte electrochemically-activated liquid and a catholyte electrochemically-activated liquid, the electrolysis cell comprising:
a chamber;
an anode electrode disposed within the chamber, and configured to be electrically connected to a power source; and
a cathode electrode disposed within the chamber, and configured to be electrically connected to the power source;
a steam generator disposed downstream from the electrolysis cell and configured to at least partially vaporize a blend of the anolyte electrochemically-activated liquid and the catholyte electrochemically-activated liquid to produce an electrochemically-activated vapor; and
a dispenser configured to dispense the electrochemically-activated vapor.
2. The steam cleaning apparatus of claim 1, wherein the steam cleaning apparatus is configured blend the anolyte electrochemically-activated liquid and the catholyte electrochemically-activated liquid at a location that is downstream from the electrolysis cell.
3. The steam cleaning apparatus of claim 1, wherein the electrolysis cell further comprises an ion exchange membrane disposed between the anode electrode and the cathode electrode.
4. The steam cleaning apparatus of claim 1, and further comprising a recovery device configured to recover soiled working liquid from a surface being cleaned.
5. The steam cleaning apparatus of claim 1, wherein the steam generator comprises:
a liquid reservoir configured to receive the anolyte electrochemically-activated liquid and the catholyte electrochemically-activated liquid from the electrolysis cell; and

a heater immersed in the liquid reservoir and configured to heat the received anolyte electrochemically-activated liquid and the received catholyte electrochemically-activated liquid, thereby at least partially vaporizing the blend of the anolyte electrochemically-activated liquid and the catholyte electrochemically-activated liquid.

6. The steam cleaning apparatus of claim 1, and further comprising a reservoir located upstream from the electrolysis cell, wherein the reservoir is configured to contain a supply of the liquid, and wherein the liquid consists essentially of water.

7. A method for cleaning, the method comprising:
electrochemically activating a liquid to generate an anolyte electrochemically-activated liquid and a catholyte electrochemically-activated liquid;
blending the anolyte electrochemically-activated liquid and the catholyte electrochemically-activated liquid to produce a blended electrochemically-activated liquid;
at least partially vaporizing the blended electrochemically-activated liquid to produce an electrochemically-activated vapor; and
dispensing the electrochemically-activated vapor.

8. The method of claim 7, wherein the liquid is electrochemically activated in at least one electrolysis cell.

9. The method of claim 7, wherein electrochemically activating the liquid comprises:

introducing a feed liquid into an electrolysis cell, the electrolysis cell having at least one cathode electrode and at least one anode electrode; and
applying a voltage potential across the at least one cathode electrode and the at least one anode electrode to generate the anolyte electrochemically-activated liquid and the catholyte electrochemically-activated liquid from the feed liquid.

10. The method of claim 9, and further comprising maintaining separation of at least two portions of the feed liquid with at least one ion exchange membrane disposed between the at least one cathode electrode and the at least one anode electrode.
11. The method of claim 7, wherein the liquid consists essentially of water.
12. The method of claim 7, wherein the liquid is electrochemically activated at a location that is upstream from a location at which the blended electrochemically-activated liquid is at least partially vaporized.
13. The method of claim 7, wherein the electrochemically-activated vapor is a dry steam vapor.
14. A method for cleaning, the method comprising:
 - introducing a first portion of a feed liquid into an anode chamber of an electrolysis cell;
 - introducing a second portion of the feed liquid into a cathode chamber of the electrolysis cell;
 - applying a voltage potential across the first and second portions of the feed water to electrochemically activate the first and second portions of the feed liquid;
 - blending the first and second electrochemically-activated portions of the feed liquid to produce a blended electrochemically-activated liquid;
 - introducing blended electrochemically-activated liquid to a steam generator;
 - at least partially vaporizing the blended electrochemically-activated liquid to produce an electrochemically-activated vapor; and
 - dispensing the electrochemically-activated vapor.

15. The method of claim 14, and further comprising maintaining separation of the anode chamber and the cathode chamber within the electrolysis cell with an ion exchange membrane.
16. The method of claim 14, wherein the feed liquid consists essentially of water.
17. The method of claim 15, wherein the first and second electrochemically-activated portions of the feed liquid are blended prior to being fed to the steam generator.
18. The method of claim 15, wherein the first and second electrochemically-activated portions of the feed liquid are at least partially blended at the steam generator.
19. The method of claim 15, wherein at least partially vaporizing the at least one electrochemically-activated portion comprises:
 - receiving the blended electrochemically-activated liquid in a liquid reservoir; and
 - heating the blended electrochemically-activated liquid in the liquid reservoir with a heater immersed in the liquid reservoir.

STATEMENT UNDER ARTICLE 19(1)

The amendments to claims 1, 7 and 14 distinguish over Reference D1 (Choi) in that a liquid is electrochemically activated to form an anolyte electrochemically-activated liquid and a catholyte electrochemically-activated liquid, and the anolyte electrochemically-activated liquid and the catholyte electrochemically-activated liquid are blended together. The resulting blend of the anolyte electrochemically-activated liquid and the catholyte electrochemically-activated liquid is then at least partially vaporized. Although, the anolyte electrochemically-activated liquid and the catholyte electrochemically-activated liquid are blended, they are initially not in equilibrium, and therefore, retain their enhanced cleaning and sanitizing properties. Thus, the apparatus of claim 1, and the methods of claims 7 and 14 each result in the production of electrochemically-activated vapor (e.g., electrochemically-activated steam) having increased cleaning and sanitizing efficiency.

Reference D1 is directed to a system that produces a silver colloidal suspension for cleaning. Reference D1 does not disclose forming an anolyte electrochemically-activated liquid and a catholyte electrochemically-activated liquid, or subsequently blending the anolyte electrochemically-activated liquid and the catholyte electrochemically-activated liquid prior to being at least partially vaporized. Thus, the combination of the blended streams and the vaporization process contains novelty and inventive step.