



H. A. W. WOOD.  
SHEET MANIPULATING MECHANISM.  
APPLICATION FILED NOV. 15, 1905.

1,133,352.

Patented Mar. 30, 1915.  
6 SHEETS-SHEET 2

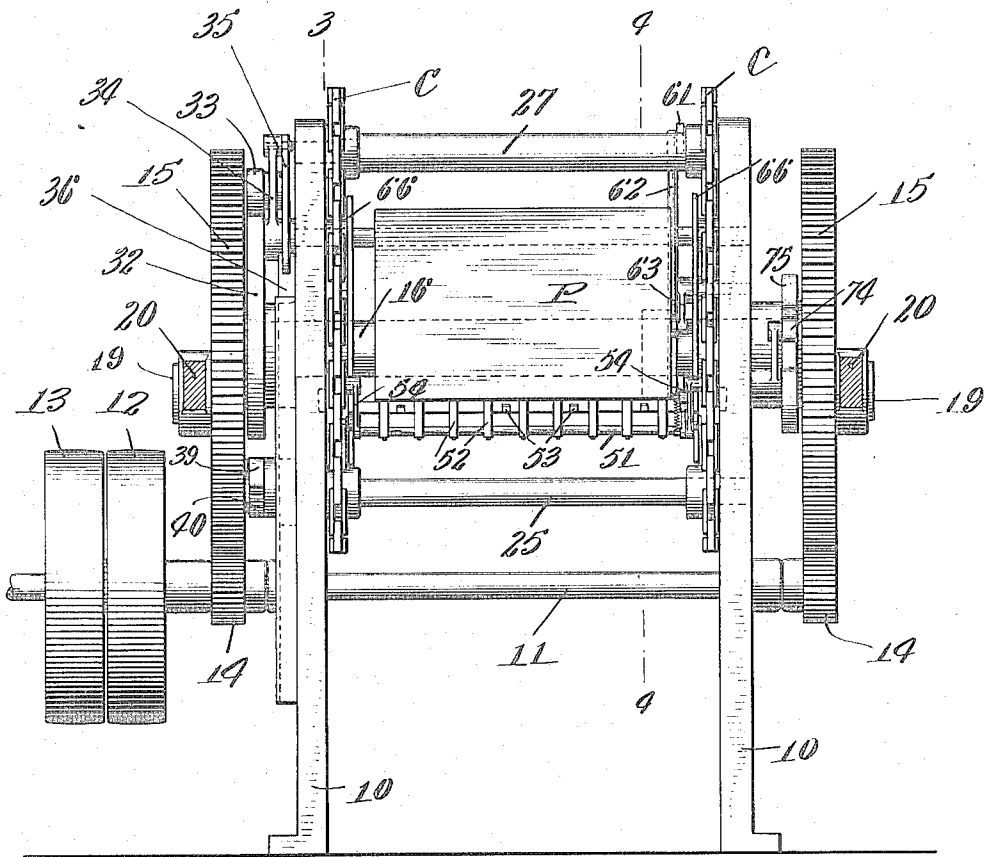

Fig. 2.

WITNESSES:  
C. F. Mason  
M. E. Regan.

INVENTOR  
H. A. W. Wood.  
BY HIS ATTORNEYS  
Sutcliffe & Sutcliffe

H. A. W. WOOD.  
SHEET MANIPULATING MECHANISM.  
APPLICATION FILED NOV. 15, 1905.

1,133,352.

Patented Mar. 30, 1915.

6 SHEETS—SHEET 3.

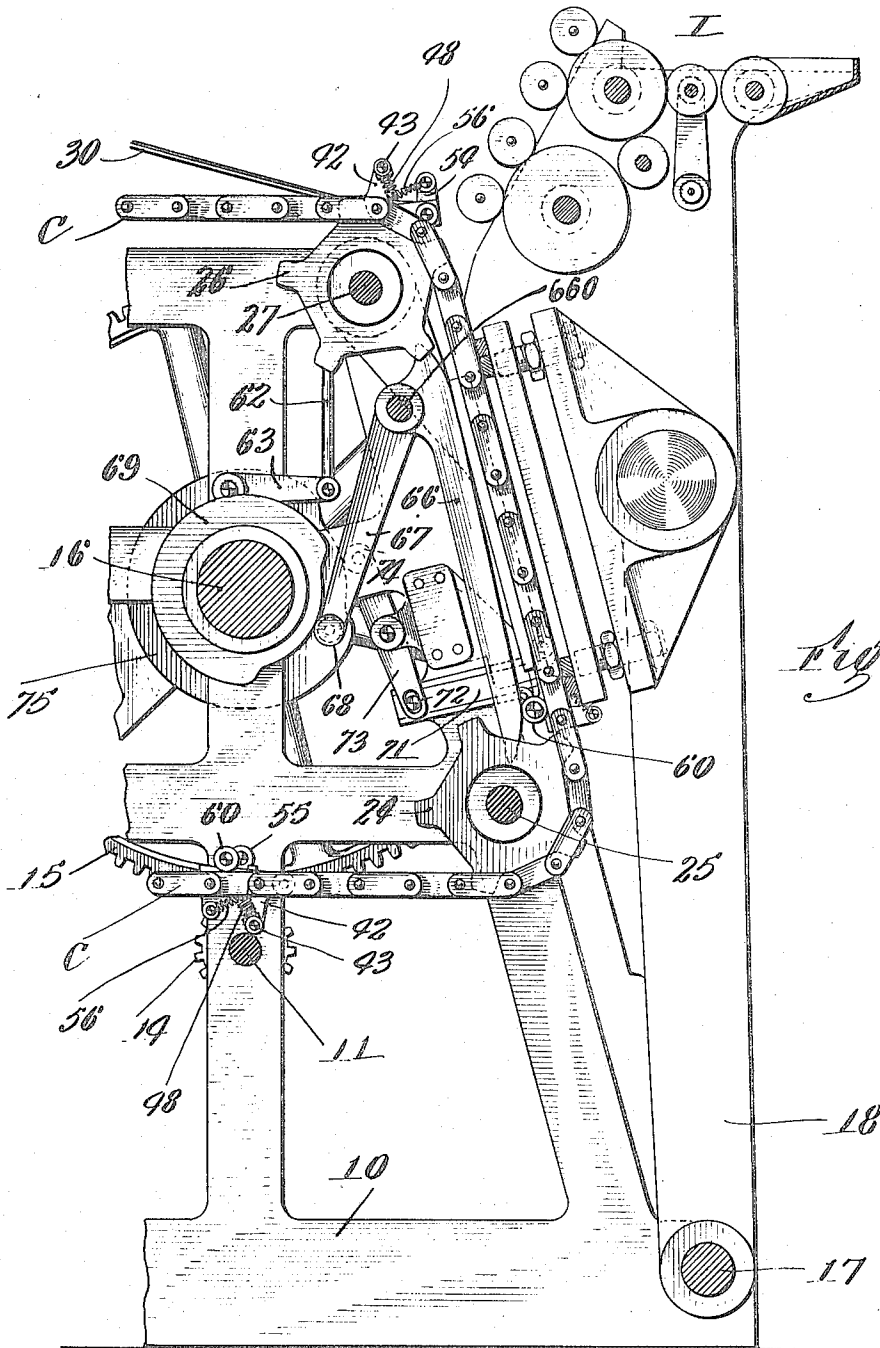

WITNESSES:

*C. F. Mason*  
*m. E. Regan*

INVENTOR

*H. A. Wood*

BY HIS ATTORNEYS  
*Sutcliffe & Sutcliffe*

H. A. W. WOOD.  
 SHEET MANIPULATING MECHANISM.  
 APPLICATION FILED NOV. 15, 1905.

1,133,352.

Patented Mar. 30, 1915.

6 SHEETS—SHEET 4.

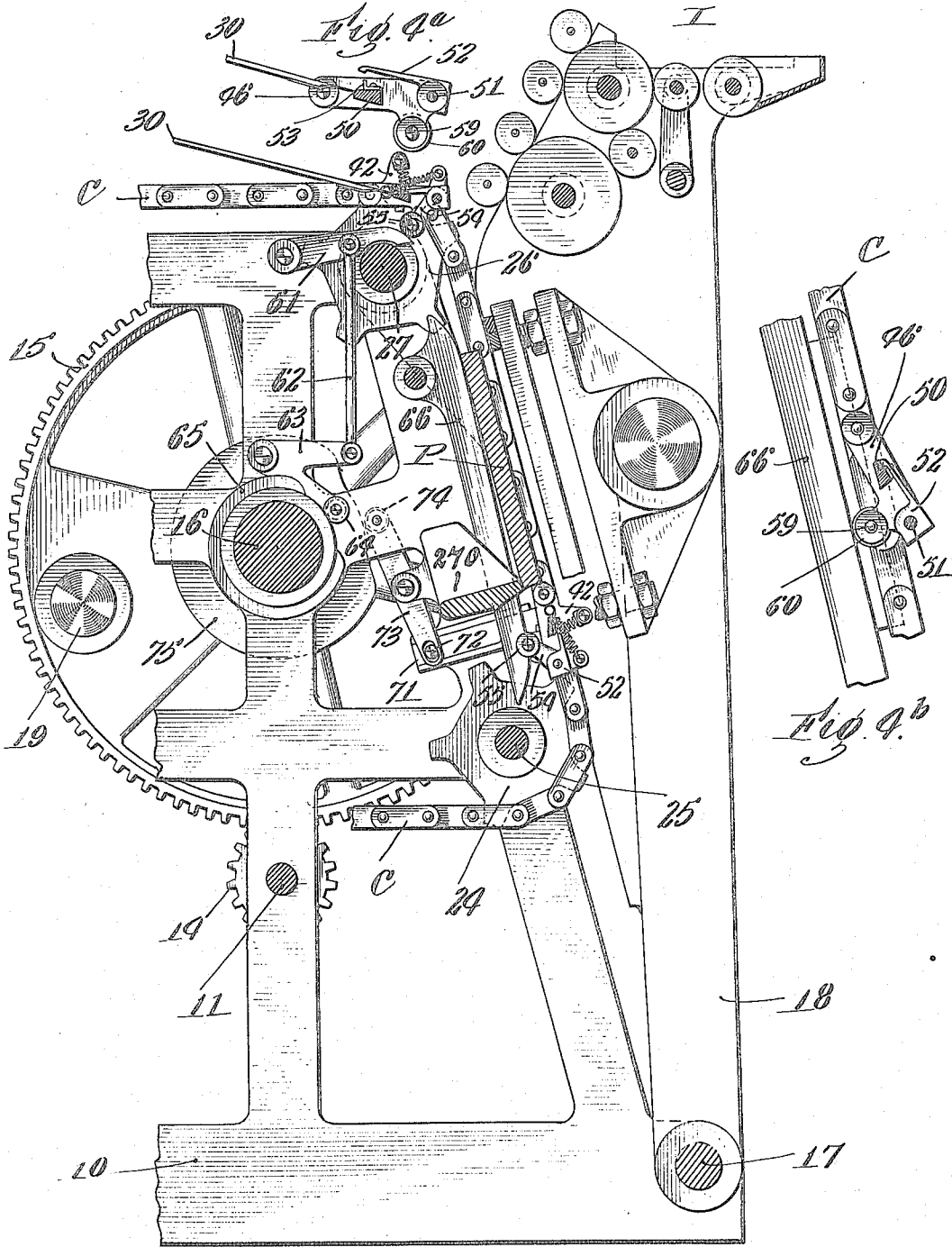

*Fig. 9.*

WITNESSES:  
 G. H. Mason  
 M. E. Regan.

INVENTOR  
 H. A. Wood.  
 BY HIS ATTORNEYS  
 S. H. Wood & Co.

H. A. W. WOOD.  
 SHEET MANIPULATING MECHANISM.  
 APPLICATION FILED NOV. 15, 1905.

1,133,352.

Patented Mar. 30, 1915.

6 SHEETS—SHEET 5.

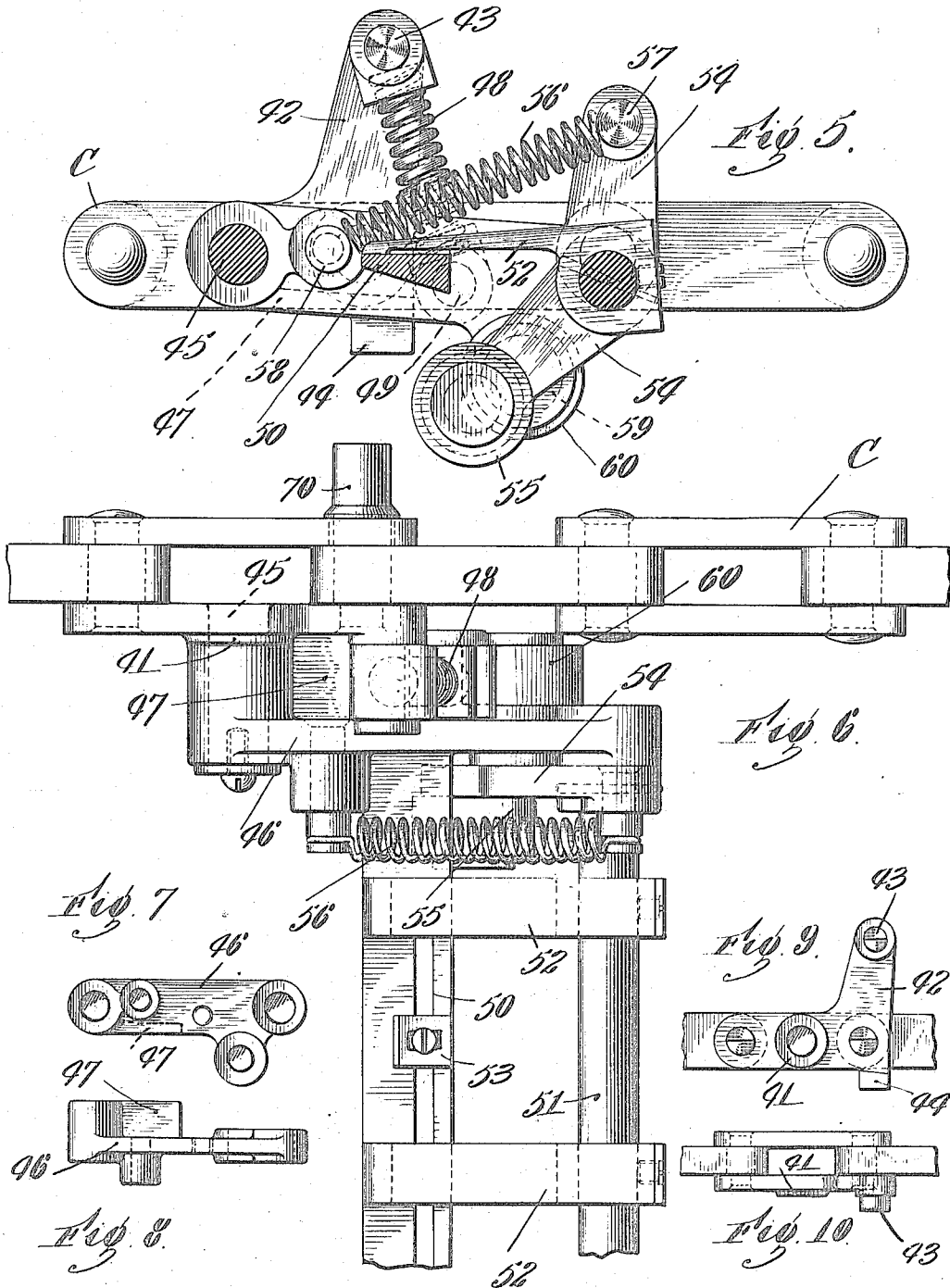

WITNESSES:

*W. F. Mason*  
*M. C. Regan*

INVENTOR

*H. A. Wise Wood*

BY HIS ATTORNEYS

*Switzger & Switzger*

H. A. W. WOOD.  
SHEET MANIPULATING MECHANISM.  
APPLICATION FILED NOV. 15, 1905.

1,133,352.

Patented Mar. 30, 1915.  
6 SHEETS—SHEET 6.

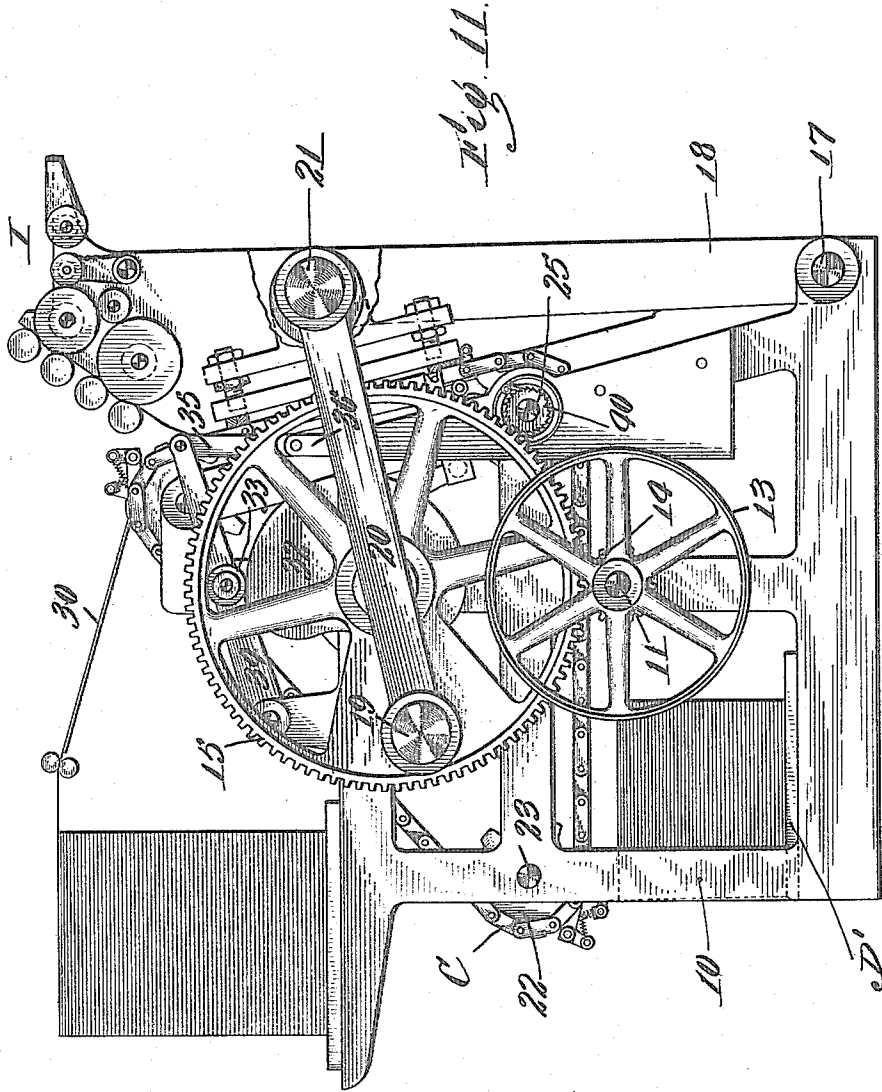

WITNESSES:

*C. H. Mason*  
*M. C. Regan*

INVENTOR

*H. A. Wise Wood*

BY HIS ATTORNEYS

*Smith & Smith*

# UNITED STATES PATENT OFFICE.

HENRY A. WISE WOOD, OF NEW YORK, N. Y., ASSIGNOR TO WOOD & NATHAN COMPANY,  
OF NEW YORK, N. Y., A CORPORATION OF NEW YORK.

## SHEET-MANIPULATING MECHANISM.

1,133,352.

Specification of Letters Patent.

Patented Mar. 30, 1915.

Application filed November 15, 1905. Serial No. 237,485.

*To all whom it may concern:*

Be it known that I, HENRY A. WISE WOOD, a citizen of the United States, and a resident of New York, in the county of New York and State of New York, have invented certain new and useful Sheet-Manipulating Mechanism, of which the following is a specification.

The object of this invention is to provide a new improved manipulating mechanism by which sheets may be fed to, carried through, and delivered from a printing press, particularly a printing press of the platen type.

To this end, the invention consists of a carrier preferably endless which is given an intermittent motion to perform these functions.

The carrier may be made in convenient form out of two endless chains, by arranging a series of gripper mechanisms between the chains, and by providing means whereby the grippers are opened and closed while the chains are stationary to secure better register. Means are also provided whereby the grippers are lifted and held away from the face of the platen as they are moved over the same and whereby the grippers are allowed to move back toward the platen when the impression is made.

The invention further consists of certain combinations hereinafter described and claimed, which will be understood from a detail description of the mechanism.

The invention is illustrated in the accompanying six sheets of drawings.

Referring to these drawings and in detail, Figure 1 is a side elevation of a mechanism arranged to embody my invention. Fig. 2 is an end view thereof. Fig. 3 is an enlarged partial sectional view taken on the line 3—3 of Fig. 2. Fig. 4 is a similar view taken on the line 4—4 of Fig. 2. Fig. 4<sup>a</sup> is a detail view illustrating the action of the grippers when they take the sheet. Fig. 4<sup>b</sup> is a detail view illustrating the lifting of a gripping mechanism as it passes over the platen. Fig. 5 is an enlarged sectional view of the construction of grippers. Fig. 6 is a plan view thereof. Fig. 7 and Fig. 8 are a side elevation and a plan of one of the parts of the gripper mechanism hereinafter described. Figs. 9 and 10 are similar views illustrating the construction of the links of

the chains which carry the grippers. Fig. 11 is a side elevation of a modification hereinafter described.

Referring to the first five sheets of drawings, the mechanism therein illustrated will be described. The mechanism is mounted in side frames 10—10 which may be tied together, if desired. Journaled in these side frames is a driving shaft 11 on which may be arranged the usual tight and loose pulleys 12 and 13 for imparting power to the machine. Pinions 14—14 are secured on the driving shaft 11 and mesh with large gears 15—15 arranged on the operating shaft 16 of the machine. A shaft 17 is fitted in the frames 10—10 and pivoted on the same are powerful levers or frames 18—18 which carry the usual chase and furniture so that a form or forms can be locked in proper position to cooperate with the platen P. The platen P is hung on shaft 27 and strikes against bracket 270 as shown in Fig. 4. This construction also affords a convenient means whereby the platen may be turned flat or into horizontal position for making ready. An inking mechanism I, of any of the usual types is arranged between the levers or frames 18—18. This inking mechanism is arranged as is common in platen printing presses so that the form inking rollers will travel down over and ink the form or forms when they are retracted or moved away from the platen P. The large gears 15—15 carry wrist-pins 19—19 which are connected by links or pitmen 20—20 to shaft 21 on the frames 18—18. The shaft 21 is made eccentric in the manner common in platen printing presses so as to constitute a throw-off mechanism; that is, so that when the shaft is in one position as the frame is moved up toward the platen, it will not contact therewith and so that when the shaft is in the other position when the frame is moved up, it will contact with the platen and print the sheet.

As shown in the drawings, the shaft 21 is in the printing position, it being understood of course, that when the form is to be tripped, the shaft is moved to its other position by means of mechanism commonly employed in platen printing presses.

The sheet manipulating mechanism consists of two chains C—C made up in principal part of the usual links. These chains are

trained over sprockets 22—22 mounted on a shaft 23 journaled in the frame, over sprockets 24—24 mounted on a shaft 25 journaled in the frames, over sprockets 26—26 secured on a shaft 27 journaled in the frames, and over sprockets 28—28 secured on a shaft 29 journaled in the frames. Shafts 23 and 29 can be studs with loose sprockets if desired. The chains carry a series of gripper mechanisms, there being as many gripper mechanisms as the chains are sheet lengths in extent. For example, in the drawings shown, the chains are made of a length corresponding to seven sheet lengths plus the necessary clearance between each set of gripper mechanism and seven sets of gripper mechanisms are arranged between the chains. The sheets are fed to the gripper mechanisms down a suitable feed-board or guides 30. An automatic feeder may be arranged in connection with the machine or the sheets may be fed by hand. The details of the feeding mechanism form no part of the present invention and therefore are not illustrated or described at length. The sheets may be fed from the position indicated at S for an underneath feed or from the position indicated at S' for a top feed.

Two delivery tables D and D' are arranged between the frames at the positions indicated on relatively opposite sides of the chains. If the sheets are delivered on the upper delivery table D they will be delivered printed side up. If they are delivered on the lower delivery table D', they will be delivered printed side down. The sheets can be delivered on either table, as desired, by the mechanism hereinafter described and this constitutes an important point in connection with the invention.

Each delivery table is provided with a set of the usual stop fingers 31 to position the sheets as they are delivered. The chains are given an intermittent movement in the same direction, equal to the distance between each set of gripper mechanism, by the following means: A cam 32 is arranged on the operating shaft 16 and engaging the same is a roller 33 secured on an arm 34 which latter is connected by a link 35 to a rack 36 which is fitted to slide vertically in suitable guides, a spring 37 being employed to keep the roller 33 in engagement with the cam 32. The rack 36 engages a pinion 38 loosely mounted on the shaft 25. This pinion carries a spring-pressed pawl 39 which cooperates with a ratchet-wheel 40 tightly secured on the shaft 25. By this arrangement, as the rack 36 moves down, the pawl 39 will run over the ratchet-wheel 40 but on the upward movement of the rack 36, the pawl will operate the ratchet-wheel and turn the shaft 25. By this arrangement, the chains will be intermittently advanced.

The mechanism is timed and arranged to

operate when the frame is retracted from the platen and so as to give a movement to the chains equal to the distance between the sets of gripper mechanisms.

The gripper mechanisms are the same in construction and one will now be described in detail and reference to follow such description should be had in Figs. 5 to 10, inclusive. A pair of the inner links of the chain directly opposite each other is constructed, so as to have a boss 41 and extending arm 42 in which is secured a pin 43 and a projection 44, it being understood of course, that these parts come on the inner side of each of the links. (See Figs. 9 and 10.) Driven into the bosses 41 are studs 45 and pivoted on these studs are gripper carrying bars 46, shown in Figs. 7 and 8, the gripper carrying bars being kept in place on the studs 45 by collars and screws. The gripper bars have projections or stops 47 which are arranged to strike against the projections 44 on the links to determine the normal position of the gripper mechanism. These projections are kept in contact with the gripper bars in their normal positions by means of springs 48 arranged between the pins 43 of the inner links of the chain and pins 49 driven into the sides of the gripper bars, the springs 48 being housed in suitable sockets pivoted on the pins 43 and 49. By this arrangement, the gripper mechanism hereinafter described, can be lifted or turned about the studs 45 as pivots but it is kept in normal position by said springs 48. Secured between the gripper bars 46 is a gripper jaw 50 made up of a piece of flat metal. A shaft 51 is journaled in bearings formed in the ends of the gripper bars 46—46 and a series of gripper fingers 52 are secured on the shaft 51. Stops 53 are secured to the gripper jaw 50 so that when the sheet is fed to the gripper mechanism it may be properly positioned. These are preferably adjustable. Secured on the shaft 51 just inside its bearing in the gripper bars, is a lever 54 which carries a roller 55. The gripper fingers are kept normally in contact with the gripper jaw by means of a spring 56. The lever 54 projects upwardly, as well as downwardly and the spring 56 is arranged between a pin 57 secured in the upward part of the lever 54 and a pin 58 secured in the gripper bar 46. A pin or stud 59 is driven into a post extending down from each gripper bar 46 and a roller 60 is journaled on each pin for a purpose hereinafter noted.

To lift the gripper fingers so that the sheet may be seized for manipulation, the following mechanism is provided: A cam lever 61 (Fig. 4) is pivoted on the inside of one of the frames. This cam lever is operated by a link 62 connected with a double-pronged lever 63, which lever carries a roller

64 bearing on a cam 65 secured on the operating shaft 16 of the machine. The cam 65 is proportioned and arranged so that when the chains come to rest the gripping fingers 52 will be raised as shown in Fig. 4<sup>a</sup>, so that the sheet can be fed in on to the gripper jaw 50 in registration with the stops 53 and so that when the sheet has been fed into this position, the gripper fingers will close down on to the gripper jaw and seize the sheet for manipulation, all while the chains are stationary, so that at the next movement of the chains, it will be carried forward down over the platen P. By opening the gripper fingers only just before the sheet is to be fed, the necessity for providing special means for keeping them open during the travel of the carrier is avoided. This secures an excellent register. It is desirable to move the gripper mechanisms over the face of the platen P without contact therewith but to allow the gripper mechanisms to come down into the same plane as the face of the platen when the impression is to be made. This is the purpose of pivoting the gripper mechanisms on the chains as before described and the following mechanism is arranged to turn the gripper mechanism in the chains as it passes over the face of the platen: Secured on a shaft 660 so as to stand at each side of the platen P are blade cams 66, one of which has an extending lever 67 provided with a roller 68 bearing on a cam 69 secured on the operating shaft 16 of the machine. The blade cams 66 are set in position to cooperate with the rollers 68 so that when the gripper mechanism moves over the upper edge of the blade cam it will be held out from the platen and the cam 69 is so arranged that the blade cams will be thrown out relatively to the platen as each gripper mechanism moves down across the platen, whereby the gripper mechanism will be moved clear of the face of the platen as it moves over the same, as shown in Fig. 4<sup>b</sup>, and whereby when the gripper mechanism is moved down over the platen, the same can drop to proper position to come substantially in line with or in the same plane as the face of the platen whereby the impression can be made on the sheet without any pinching or creasing of the paper.

It is also extremely desirable to register the chains as the printing is done. For this purpose pins 70, shown in Fig. 6, which connect the links of the chain at the points where the gripper mechanisms are carried, are extended to form registering pins. Fitted to slide in suitable sockets are bars 71 which have socketing or tapering mouths 710, as shown in Fig. 1. Each of these bars carries a pin 72 which fits in a pivoted lever 73. One of these pivoted levers carries a roller 74 which works on a cam 75 secured on the shaft 16 of the machine. This cam is

so arranged that when the chain comes to rest, the bars 71 will move up and the notched or tapering mouths 710 of the same will engage the registering pins 70 and thus register the gripping mechanism that is below the platen so that the impression will be made in the proper position on the sheet and so that any irregularities or slack in the chains will be compensated for.

After the sheets have been printed, they will be carried by the movement of the chains before described out over the delivery tables D' and D. If it is desired to deliver the sheets on the table D' with their printed sides down, cam 76 is secured to the side frame in position to cooperate with the roller 55 so that as the chains come to rest, the grippers which are at the left of the delivery table D' will be opened and the sheet allowed to settle down on the delivery table. This delivery can take place very easily and accurately as the grippers open substantially as the chains come to rest. On the other hand if it is desired to deliver the sheets on the delivery table D printed side up, cam 76 is removed from the position previously described and set at the right of the delivery table D. The delivery then takes place substantially as previously described except that the sheets are delivered the other side up. Either method of delivery can be adopted by setting the cam 76 to cooperate with the proper delivery table. Thus by this mechanism, sheets are taken, carried over the platen, brought in line or in the same plane as the platen, registered in proper position, printed, carried forward, and delivered either side up as desired. By using this sheet manipulating mechanism in connection with the automatic feeder, a very rapid and accurately working printing mechanism is provided.

In some cases it is not necessary to arrange the machine for delivering the sheets both ways and when it is not desired, the machine can be somewhat simplified, as illustrated in Fig. 11.

As shown in Fig. 11, the mechanism is arranged substantially as before described except that the delivery table D is omitted and the delivery table D' alone provided so that the sheets are delivered printed side down. For this arrangement, the sprockets 28—28 and the shaft 29 can be omitted and the machine may be more compact. This arrangement allows for the convenient use of a top side feeding mechanism.

In some instances it may be desirable to move the chains so as to carry the sheets up over the platen and this arrangement, while within the scope of the broad claims made in this application, is specifically shown, described and claimed in a companion application for patent filed January 22, 1906, Serial No. 297,327.

Many other modifications may be worked out and other mechanisms may be devised by a skilled mechanic without departing from the scope of the invention as expressed in the claims.

Having thus fully described my invention, what I claim and desire to secure by Letters-Patent is:—

1. A sheet manipulating mechanism for a printing press, comprising a carrier, a gripper mechanism thereon, independently movable means for holding said gripper mechanism away from the impression surface of the press as it passes through the press, and for permitting its retraction when it reaches the end thereof to allow the sheet to come on the impression surface during impression.

2. A sheet manipulating mechanism, comprising a carrier, a series of gripper mechanisms arranged thereon, means for moving said carrier, a printing mechanism through which the carrier is adapted to move the sheets, and movable means for moving each gripper mechanism away from the impression surface of the printing mechanism as it passes through the same and for allowing the gripper mechanism to come in line with the impression surface during the impression.

3. A sheet manipulating mechanism comprising a carrier, a series of gripper mechanisms arranged in the carrier, means for intermittently advancing the carrier, a platen printing mechanism through which the manipulating mechanism carries the sheets, and movable means for moving each gripper mechanism away from the face of the platen as it passes over the same and for allowing the same to come in line with the platen during impression.

4. A sheet manipulating mechanism comprising a carrier, a series of gripper mechanisms arranged in the carrier, means for intermittently advancing the carrier, a platen printing mechanism through which the manipulating mechanism carries the sheets, and means for registering the carrier with the platen for each impression, comprising a slide having a tapering mouth.

5. A sheet manipulating mechanism, comprising a carrier, means for moving the carrier, a printing mechanism through which the carrier moves, and means for registering the carrier with the printing mechanism for each impression, said means comprising a stud on the carrier, a slide having a tapering mouth adapted to engage and center said stud, and means for intermittently reciprocating said slide.

6. A sheet manipulating mechanism comprising two chains, a series of gripper mechanisms pivoted in the chains, means for intermittently advancing the chains.

platen printing mechanism through which the manipulating mechanism carries the sheets, movable means for turning each gripper mechanism on its pivot as the same passes over the face of the platen, and means for allowing the movable means to recede with the gripper mechanism when the latter reaches the end of the platen.

7. A sheet manipulating mechanism comprising two endless chains, a series of gripper mechanisms arranged in the chains, means for intermittently advancing the chains, a printed mechanism through which the manipulating mechanism carries the sheets, two delivery tables arranged on relatively opposite sides of the chains, and means whereby the grippers may be operated to deliver the sheets on either table as desired, whereby the sheets may be delivered either printed side up or printed side down.

8. A sheet manipulating mechanism comprising a carrier, a series of gripper mechanisms arranged in the carrier, means for intermittently advancing the carrier in one direction, a platen printing mechanism through which the manipulating mechanism carries the sheets, and means for holding the gripper mechanism away from the platen of the printing mechanism and then bringing it in toward the same so that the sheet may aline with the platen during impression.

9. A sheet manipulating mechanism comprising a chain, a series of gripper mechanisms arranged on the chain, a shaft for advancing the chain, means for intermittently rotating the shaft, and constantly rotating means independent of said shaft for opening the grippers when the shaft is stationary and before it commences to rotate.

10. A sheet manipulating mechanism comprising an endless chain, a series of gripper mechanisms carried thereby, an operating shaft, a shaft for advancing the chain, means for intermittently rotating the last named shaft from the operating shaft, and means for operating the grippers from said operating shaft when the other shaft is stationary and before it commences to advance.

11. In a sheet manipulating mechanism, the combination of an endless chain, a gripper mechanism carried thereby, comprising grippers, means for intermittently advancing the chain in one direction, means for opening the grippers when the chain is stationary and before it commences to advance, and means for thereafter closing the grippers while the chain is still stationary and before it commences to advance.

12. A sheet manipulating mechanism comprising two chains, a series of gripper mechanisms arranged in the chains, a platen, means for intermittently advancing the chains relatively to the platen, and means

for holding each gripper mechanism away from the face of the platen as it passes over the same comprising blade cams arranged at the sides of the platen.

5 13. A sheet manipulating mechanism comprising two chains, a series of gripper mechanisms pivoted in the chains, a platen, means for intermittently advancing the chains relatively to the platen, and means 10 for turning each gripper mechanism as it passes over the face of the platen comprising cam actuated blades pivoted at the sides of the platen.

14. A sheet manipulating mechanism comprising two chains, a series of gripper mechanisms pivoted in the chains, a platen, means for intermittently advancing the chains relatively to the platen, and means 15 for turning each gripper mechanism on its pivot as the same passes over the face of the platen comprising blades pivoted at the sides of the platen, cams actuated to operate said blades, and rolls on each gripper mechanism.

25 15. A sheet manipulating mechanism comprising two chains, a series of gripper mechanisms arranged in the chains, means for intermittently advancing the chains, a platen printing mechanism through which 30 the manipulating mechanism carries the sheets, and means for registering the chains

with the platen for each impression comprising pins carried by the chains and cam actuated notched registering bars arranged at the sides of the platen.

16. A sheet manipulating mechanism comprising two endless chains, a series of gripper mechanisms arranged in the chains, means for intermittently advancing the chains, a printing mechanism through 40 which the manipulating mechanism carries the sheets, two delivery tables arranged on relatively opposite sides of the chains, and a cam which may be placed in either one of two positions so that the sheets may be de- 45 livered on either table as desired.

17. The combination with a series of gripper mechanisms, of a platen, means for moving the gripper mechanisms over the platen, and means for turning each gripper mechanism as it passes over the face of the platen, said means comprising a blade pivoted at the side of the platen, and means for swinging the blade.

Signed at New York, in the county of 55 New York and State of New York this 14th day of November, A. D. 1905.

H. A. WISE WOOD.

Witnesses:

PAUL NATHAN,  
ISABELLA W. KNOX.