

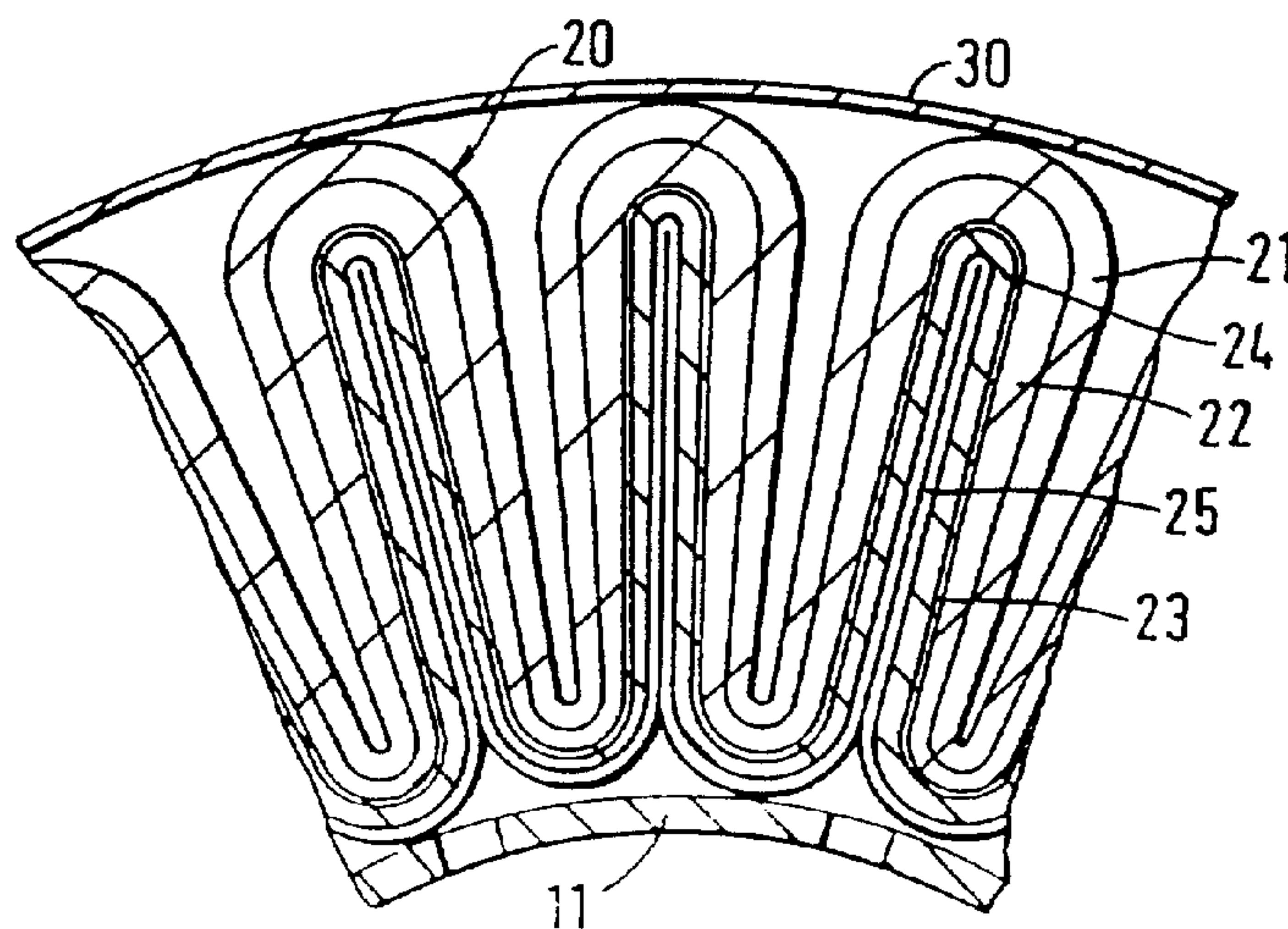

(11) (21) (C) **2,048,086**  
(22) 1991/07/29  
(43) 1992/01/31  
(45) 2000/06/13

(72) Miller, John D., US  
(72) Williamson, Kenneth M., US  
(72) Swiezbin, Joseph R., US  
(73) Pall Corporation, US  
(51) Int.Cl.<sup>5</sup> B01D 29/21  
(30) 1990/07/30 (07/559,335) US  
(30) 1991/07/22 (07/733,625) US  
(54) **FILTRE**  
(54) **A FILTER**



(57) A filter includes a pleated filter element having longitudinally extending pleats and a wrap member wrapped around the filter element. The wrap member is joined to the peaks of the pleats and has openings for increasing the dirt capacity of the filter. The filter element may be a composite of a filter layer, upstream and downstream support and drainage layers, a cushioning layer between the upstream support and drainage layer and the filter layer, and polymeric beads on the downstream side of the downstream support and drainage layer. An extruded polymeric mesh may comprise one or both of the upstream and downstream support and drainage layers.

## ABSTRACT OF THE DISCLOSURE

A filter includes a pleated filter element having longitudinally extending pleats and a wrap member wrapped around the filter element. The wrap member is joined to the peaks of the pleats and has openings for increasing the dirt capacity of the filter. The filter element may be a composite of a filter layer, upstream and downstream support and drainage layers, a cushioning layer between the upstream support and drainage layer and the filter layer, and polymeric beads on the downstream side of the downstream support and drainage layer. An extruded polymeric mesh may comprise one or both of the upstream and downstream support and drainage layers.

The present invention relates to a filter and more particularly to a corrugated filter for removing one or more substances from a fluid flowing through the filter. It also relates to a filter having a high dirt capacity and enhanced fatigue resistance.

In filtration systems which have repeated or cyclical fluctuations in the flow rate across a filter, fatigue failure of the filter can be a problem. This is especially true for systems with wide flow excursions, e.g., from zero to full flow and back to zero, such as are experienced in filtration systems for piston-type pumps as used in fluid power systems. The flow cycles cause coincident cycles in the differential pressure across the filter, typically resulting in a "breathing type" flexure within the pleated medium of the filter. If the pleated medium is a composite having a filter layer and a support and drainage layer, as the pleated medium flexes, the support and drainage layer can rub back and forth along the filter layer. Because the support and drainage layer is typically much more coarse than the filter layer, this rubbing may produce weak spots which can rupture in service. This type of failure is known as a fatigue failure.

Another problem of conventional filters is that

they may have a low dirt capacity when the liquid flows through the filter element unevenly. For example, more liquid may flow through the upper portion of a filter element than through the lower portion. Consequently, more dirt is deposited on the upper portion of the filter element than on the lower portion. This uneven loading of the filter element can lower the dirt capacity of the filter element. The lower the dirt capacity of a filter element, the more often it is necessary to replace the  
10 filter, resulting in increased material and labor costs.

Accordingly, the present invention provides a filter comprising a pleated filter element including longitudinally extending pleats having peaks, and a wrap comprising one or more strips of material each spirally wrapped around the filter element in one or more turns and joined to the peaks of the pleats, the total area of openings in the one or more strips and/or between adjacent turns of the one or more strips being less than about one-half of the total area of the surface of the whole tubular  
20 envelope defined by the peaks of the pleats.

According to one aspect of the present invention the filter element comprises a pleated composite having a filter layer, a support and drainage layer, and means disposed between the filter layer and the support and drainage layer for resisting abrasion of the filter layer by the support and drainage layer.

According to another aspect of the present invention, the filter element comprises a pleated composite having first and second extruded polymeric mesh layers and a filter layer positioned between them.

Filters and filter elements embodying the present invention are highly reliable and have an enhanced resistance to fatigue failure, an improved dirt capacity, and an extended service life. By wrapping the pleats with a wrap, movement of the pleats is restrained and abrasion of the filter medium is minimized. In addition, the wrap produces a more uniform flow distribution over the length of the filter. Consequently, dirt is more evenly deposited on the filter element, increasing the useful life of the filter. The wrap also helps the filter to resist radially outwardly directed forces and can prevent the filter element from swelling outward. By providing an abrasion resisting means between the filter layer and the support and drainage layer, the support and drainage layer is prevented from abrading the filter layer and producing a weak spot in the filter layer. Consequently, there are fewer fatigue failures. By including one or more extruded polymeric mesh layers in the pleated composite, the filter elements are easy to fabricate and corrugate and yet are highly

effective.

Figure 1 is a partially cut-away elevation of an embodiment of a filter equipped with a wrap member.

5 Figure 2 is a transverse cross-sectional view of a sector of the embodiment of Figure 2.

Figure 3 is a perspective view of a filter element prior to corrugation.

10 Figure 4 is an elevation of a portion of the filter element of Figure 3 after corrugation as viewed from the downstream side of the element.

Figure 5 is a cross-sectional view of the filter element of Figure 4 taken along Line V-V of Figure 4.

15 Figure 6 is an elevation of another embodiment of a filter with the wrap member partially removed.

Figure 7 is an elevation of another embodiment of a filter.

20 Figure 8 is a perspective view of another embodiment of a filter.

Figure 9 is an elevation of another embodiment of a filter.

A number of preferred embodiments of a filter will now be described while referring to the accompanying drawings. Figure 1 is a perspective view of a first embodiment equipped with a spiral wrap member, and Figure 2 is a transverse cross-sectional view of a sector of the embodiment of Figure 1. As shown in Figure 1, the filter 10 of

this embodiment has a hollow pleated filter element  
20 with longitudinal pleats. A hollow, rigid  
tubular core 11 may be disposed inside the hollow  
center of the filter element 20 to give the filter  
5 element 20 sufficient strength to resist the  
inwardly directed forces which act on the filter  
element 20. The core 11 can be made of any  
sufficiently strong material which is compatible  
with the fluid to be filtered. For example, the  
10 illustrated core 11 is made of a perforated metal,  
but, alternatively, it can be made of a polymeric  
material.

A blind end cap 12 and an open end cap 13 may  
be fitted over the two ends of the filter element 20  
15 to direct the fluid through the filter element 20.  
Alternatively, both end caps can be open or can  
include connectors to link a stack of filter  
elements. The end caps 12 and 13 may be fashioned  
from any suitably impervious material, such as a  
20 metallic or polymeric material, which is compatible  
with the fluid to be filtered. The end caps 12 and  
13 may be secured to the ends of the filter element  
20 by any suitable means, including a bonding agent  
such as an adhesive or a potting compound.  
25 Alternatively, the end caps 12 and 13 may be melt-  
bonded to the ends of the filter element 20 or  
joined by means of spin bonding or sonic welding.  
The ends of the hollow core 11 may be secured to the  
two end caps 12 and 13 by similar means.

The filter element 20 itself can be configured in a variety of ways. For example, the filter element can have an upstream support and drainage layer, a filter layer, and a downstream support and drainage layer. However, the present inventors found that the fatigue resistance of a filter element can be greatly increased by the provision of a cushioning layer between the filter layer and either or both of the support and drainage layers. Figure 2 illustrates an example of such a filter element 20. It has a multi-layer, composite construction including an upstream support and drainage layer 21, a cushioning layer 22, a filter layer 23, and a downstream support and drainage layer 24. The exemplary filter element illustrated in Figure 2 also includes polymeric beads 25 disposed on the downstream surface of the downstream support and drainage layer 24.

The support and drainage layers are preferably very open, allowing fluid to flow laterally and to uniformly distribute the fluid across the surface of the filter layer. Thus, the support and drainage layers typically have a very low edgewise flow resistance. The support and drainage layers also prevent the pleated surfaces of the filter layer 23 from coming into contact with one another and thereby reducing the effective surface area of the filter layer 23. The support and drainage layers do so by providing a positive spacing (fanning) between

adjacent pleats of the filter layer.

Any suitable woven or nonwoven material having good porosity can be used for the upstream support and drainage layer 21 as well as the downstream support and drainage layer 24. Furthermore, either layer may be fabricated from one or more of natural fibers, polymeric materials, and glass. In a preferred embodiment, the upstream support and drainage layer 21 comprises an extruded polymeric mesh. The mesh can be fabricated from any polymeric material, including polyester, polypropylene, or polyamide such as nylon, which is suitable for the fluid being filtered and for the applicable filtration parameters such as temperature. For example, polypropylene might be preferable to nylon for filtering hot water. The thickness of the mesh is preferably in the range from about 0.25mm (0.010 inch) to about 0.64mm (0.025 inch) but may be less than 0.25mm (0.010 inch) or more than 0.64mm (0.025 inch). The number of strands per centimeter (inch) is preferably in the range from about 4 (10) to about 12 (30) in each linear dimension but may be less than 4 (10) or more than 12 (30). For example, the mesh may have up to 32 (80) or more strands per centimeter (inch) in each linear dimension. The mesh is preferably as smooth as possible to reduce abrasion between it and the underlying layers. Extruded polymeric mesh is generally preferable to other support and drainage materials, including

woven and nonwoven fibrous webs and polymeric netting, because it is so smooth and because it typically does not shrink during fabrication and corrugation of the filter element. An extruded  
5 polymeric mesh available from Nalle Corporation is particularly smooth. For example, it has no significant irregularities such as knobs at the intersections of the strands of the mesh which might otherwise abrade the filter layer. A nylon mesh  
10 available from Nalle Corporation under the trade designation NIF020S 13x13, where 020 indicates the thickness in thousandths of an inch and 13x13, indicates the number of strands per linear inch in the x and y directions, is especially preferred.  
15 Another example of a suitable material for the upstream support and drainage layer is a nylon sheathed polyester nonwoven material sold by BASF of Williamsburg, Virginia under the trade designation Colback 50. However, a Nalle extruded mesh is  
20 preferable to Colback 50 because it is less abrasive and results in a significantly higher dirt capacity.

A principal purpose of the cushioning layer 22 is to prevent abrasion between the support and drainage layer and the filter layer. The support  
25 and drainage layer typically has good drainage properties because it is fashioned from relatively large fibers or filaments. Consequently, it generally has a rougher surface than the filter layer. When such a material is laminated directly

to the filter layer 23, significant abrasion of the filter layer 23 results when the filter element 20 undergoes flexing, for example, due to pressure cycles, and the support and drainage layer repeatedly rubs against the filter layer. However, when a cushioning layer 22 which is smoother than the upstream drainage layer is interposed between the support and drainage layer and the filter layer 23, the abrasion of the filter layer 23 can be greatly reduced, resulting in an increase in the useful life of the filter element 20.

The cushioning layer 22 is preferably formed of a thin, very porous material. For example, the cushioning layer preferably has a thickness of less than 100 micrometers. It is also preferably formed from a material which can be characterized as smooth or as smooth and tough. For example, it may be a non-abrasive, nonwoven material with a high tensile strength. A preferred material for the cushioning layer 22 is a wet-laid polyester nonwoven material sold by Hirose Corporation under the trade designation 05TH08. Other preferred materials include a nylon nonwoven material available from Fiberweb North America Inc. under the trade designation Cerex and a nonwoven polyester material available from Reemay Corporation under the trade designation Reemay, such as Reemay 2006 or Reemay 2250. Of these materials, the materials from Hirose and Reemay are most preferred. However, any

suitable woven or nonwoven material which is smoother (less abrasive) than the upstream drainage layer 21 may be used.

The filter layer 23 may be selected in accordance with several factors, including the nature of the fluid being filtered, the nature and size of the contaminants in the fluid, and the acceptable pressure drop across the filter element 20. The filter layer 23 may be any suitable filter medium. For example, the filter medium may be fashioned as a membrane or a woven or nonwoven fibrous sheet and may be fabricated from a natural or synthetic polymer or glass. Thus, the filter medium may comprise a nonwoven sheet principally including cellulose fibers or essentially consisting of glass fibers with a resin binder. Furthermore, the filter medium may have any desired pore structure, including a graded pore structure, and any desired rated pore size. However, the rated pore size of the filter layer 23 is preferably less than the rated pore size of the upstream or downstream support and drainage layers. In a preferred embodiment, the filter layer 23 comprises a suitable grade of a glass fiber acrylic bonded medium with an integral substrate providing additional strength. Preferred media, including a family of fibrous filter media having various binder resins, are available from Pall Corporation under the trade names Ultipor and Pallflex.

The downstream support and drainage layer 24 typically has greater mechanical strength than the filter layer 23 and therefore serves to protect the more delicate filter layer 23 from tearing or distortion during corrugation or use. One example of a suitable material for use as the downstream drainage layer 24 is a paper available from Dexter Company under the trade designation T-244.

As shown in Figure 2, the filter element 20 may include polymeric beads 25 formed on the downstream surface of the downstream support and drainage layer 24 on each of the pleats 26 of the filter element 20. Within each pleat 26, the beads 25 are joined to themselves and serve as spacers to define flow channels 27 within the pleat 26 and ensure proper fluid flow through the pleat 26. It is also possible to provide polymeric beads 25 on the upstream side of the filter layer 23 as well as on the downstream side.

The polymeric beads 25 may be formed from a variety of materials including many thermoplastic or thermosetting materials. Thus, the polymeric beads 25 may be formed from a material comprising a polyester, polyamide, or polyolefin resin.

Furthermore, the polymeric beads 25 may be applied in parallel strips along the downstream surface of the downstream support and drainage layer 24 in any suitable manner. For example, the polymeric beads 25 may be formed from a hot melt adhesive and

applied continuously from an evenly spaced multi-orifice dispensing head with the downstream support and drainage layer 24 moving under the dispensing head, preferably at a constant velocity, producing  
5 several continuous, parallel beads. The hot melt adhesive may be applied to the downstream support and drainage layer 24 either before or after filter element 20 has been formed into a composite.

In a modification of this method, the hot melt  
10 adhesive may be applied intermittently from the dispensing head or from an unevenly spaced multi-orifice dispensing head to produce several discontinuous, parallel beads or several unevenly spaced parallel beads. In other alternatives, a  
15 granular polymeric material may be applied by extrusion from a multi-orifice extrusion head; a plastisol polyurethane may be applied from a multi-orifice dispenser and then cured with an in-line heating device; or a solvent based adhesive or  
20 potting compound may be applied from a multi-orifice dispenser and the solvent may then be flashed by a heating/ventilation device.

As applied to a support and drainage layer 24, the bead material preferably has a surface tension  
25 high enough to prevent excessive wetting of the support and drainage layer 24 or wicking through the support and drainage layer 24 but not so high as to prevent adhesion between the beads 25 and the support and drainage layer 24. This minimizes flow

restriction through the exemplary filter element since the surface of the support and drainage layer 24 which is in contact with the beads 25 is effectively blocked. The contact angle between the 5 beads 25 and the downstream drainage layer 24, as measured by the Sessile method, may preferably be in the range from about 100° to about 120°.

Various cross-sectional shapes of the beads 25 are suitable. The most preferred shape has a 10 needle-like cross section. This shape minimizes the contact area between the bead 25 and the support and drainage layer 24. However, this shape is difficult to produce at reasonable production rates. For large scale production, a generally circular cross 15 section is preferred. Other suitable shapes include triangular, diamond, square, and rectangular cross sections.

The size of each bead 25 and the spacing between the beads 25 may vary. The size of the 20 beads 25 is determined by the size of the orifice in the dispensing head, the relative velocity between the dispensing head and the downstream drainage layer 24, and the viscosity of the bead material. For many applications, the diameter of the beads may 25 preferably be in the range from about 0.1 to about 0.5 millimeter (about 4 to about 20 mils).

The spacing between beads 25 is preferably selected so that the stress deformation, i.e., deflection, of the pleated composite satisfies both

of the following conditions: (1) the elastic limit of the filter medium comprising the filter layer 23, i.e., the maximum unit of stress beyond which the filter medium will not return to its original shape, is not exceeded and (2) the deflection of the composite during normal operation does not increase the flow resistance in the flow channels 27 more than 10 percent. For many applications, the spacing between evenly spaced beads 25 is preferably such that about 2 to about 8 beads per centimeter (about 5 to about 20 beads per inch) or, more preferably, about 3 to about 6 beads per centimeter (about 8 to about 15 beads per inch) are applied to the downstream drainage layer 24.

Once the beads 25 have been applied to the downstream support and drainage layer 24, then the upstream support and drainage layer 21, the cushioning layer 22, the filter layer 23, and the downstream support and drainage layer 24 with the beads 25 are fed into a corrugator, such as a Chandler "grab and fold" type corrugator or a Rabofsky "cam actuated blade" type corrugator. The various layers of the filter element may be formed into a composite before being fed into the corrugator, or layers including the downstream support and drainage layer 24 with the beads 25 may be fed individually into the corrugator, which then forms the composite at the same time it forms the pleats 26 in the filter arrangement 10. It is

typically preferable to preheat the extruded polymeric mesh before it enters the corrugator so it will set well after the composite has been corrugated.

5           Figure 3 is a perspective view of an example of a composite filter element 20 prior to corrugation, Figure 4 is an elevation of a portion of the filter element 20 after corrugation, and Figure 5 is a transverse cross-sectional view taken along Line V-  
 10           V of Figure 4 of a portion of the corrugated filter element 20. As shown in Figures 4 and 5, each pleat 26 extends generally perpendicularly to the beads 25 and includes an open end 26a, a bight end 26b, and first and second opposing sides 26c, 26d. The  
 15           portions of each bead 25 which extend along the opposing sides 26c, 26d of each pleat 26 are joined to one another, defining flow channels 27 within each pleat 26 between adjacent beads 25 and the opposing sides 26c, 26d. Because the downstream  
 20           support and drainage layer 24 and beads 25 are preferably positioned on the downstream surface of the filter layer 23 to resist the pressure drop across the filter 10 during normal operation, the flow channels 27 are preferably drainage channels.

25           Care should be taken in the alignment of the support and drainage layer 24 within the corrugator to ensure that the beads 25 oppose themselves in the pleats 26 so the opposing portions of the beads 25 can be joined. If the beads 25 are formed from a

hot melt adhesive, heated panels in the corrugator may be used to tack the beads together. Beads comprising other types of materials may require coating by an adhesive or softening by a solvent for this purpose. After the filter element 20 has been corrugated, it may be desirable to set the tacked beads in a forced convection oven. It may also be desirable to cure any binders in the filter medium of the filter layer 23 at the same time the beads 25 are being set. Alternatively, the beads 25 may be set and the filter medium may be cured in a tunnel oven during a continuous production process. Of course, the setting of the beads 25 and the curing of the filter medium should be done at temperatures which are not deleterious to the other components of the filter. Furthermore, all of the cured components of the filter element should be compatible with the fluid to be filtered.

In corrugating the filter element 20 and setting the beads 25, each bead 25 in the pleat 26 is preferably joined to itself the entire distance from the bight end 26b to the open end 26a of the pleat 26. Furthermore, the radius at the bight end 26b of the pleat 26 is preferably as small as possible, and preferably essentially zero, to maximize resistance to fatigue failure which may result from flexure of the filter element 20 during pulsating flow conditions. However, the beads 25 must not be over-compressed, since over-compression

would cause excessive blinding of the filter element 20 and would reduce the cross-sectional area of the flow channel 27. Thus, when corrugating the filter element 20, it may be desirable to secure the filter  
5 element 20 in a spring-loaded fixture with positive stops to prevent over-compression and a slight reverse-curve to ensure the minimum radius at the bight end 26b of the pleat 26.

By joining the opposing portions of each bead  
10 25, the flow channels 27 within each pleat 26 remain relatively open even when the filter 10 is used to filter a pulsating flow at high differential pressures. Thus, the filter element has a greater resistance to flow fatigue and therefore provides  
15 more reliable service and a greater service life than many conventional filters.

Alternatively, the downstream support and drainage layer may comprise an extruded polymeric mesh such as that described with respect to the  
20 upstream support and drainage layer. For example, the downstream support and drainage layer may be an extruded mesh available from Nalle Corporation, such as the extruded nylon mesh available under the trade designation NIF020S 13x13.

25 If the extruded mesh is sufficiently smooth, it may be preferable not to include a cushioning layer between the filtering layer and the downstream extruded mesh layer. Alternatively, a cushioning layer may be positioned between the filtering layer

and the downstream mesh. The characteristics of the cushioning layer between the filtering layer and the downstream mesh are very similar to those of the cushioning layer between the filtering layer and the upstream mesh. However, the downstream cushioning layer also preferably has sufficient strength to withstand the forces associated with the pressure drop across the filtering layer. The preferred materials listed for the upstream cushioning layer are also the preferred materials for the downstream cushioning layer.

A number of preferred examples of composite pleated filter elements are listed below.

	Element A	
	Upstream s/d layer -	Nalle extruded mesh (NIF.013-13-13)
5	Cushioning layer -	Hirose wet-laid polyester nonwoven (05TH08)
	Filter layer -	Pall Ultipor medium (suitable grade)
10	Downstream s/d layer -	Dexter Company T-244
	Polymeric bead spacers -	Hot-melt adhesive
<hr/>		
	Element B	
15	Upstream s/d layer -	Nalle extruded mesh (NIF020S 13x13)
	Cushioning layer -	Reemay 2006 nonwoven polyester
20	Filter layer -	Pall Ultipor medium (suitable grade)
	Cushioning layer -	Cerex nylon nonwoven (suitable grade)
25	Downstream s/d layer -	Nalle extruded mesh (N1F020S 13x13)
<hr/>		
	Element C	
30	Upstream s/d layer -	Nalle extruded mesh (NIF.013-13-13)
	Cushioning layer -	Cerex nylon nonwoven (.4 oz/sq. yard)
35	Filter layer -	Pall Ultipor medium (suitable grade)
	Downstream s/d layer -	Dexter Company T-244
	Polymeric bead spacers -	Hot-melt adhesive
<hr/>		

	Element D		
	Upstream s/d layer -	Colback 50	
5	Cushioning layer -	Hirose wet-laid polyester nonwoven (05TH08)	
	Filter layer -	Pall Ultipor medium (suitable grade)	
10	Downstream s/d layer - Polymeric bead spacers -	Dexter Company T-244 Hot-melt adhesive	
<hr/>			
	Element E		
	Upstream s/d layer -	Colback 50	
15	Cushioning layer -	Cerex nylon nonwoven (.4 oz/sq. yard)	
	Filter layer -	Pall Ultipor medium (suitable grade)	
20	Downstream s/d layer - Polymeric bead spacers -	Dexter Company T-244 Hot-melt adhesive	
<hr/>			

Of these five examples, Elements A and B are the most preferred partly because the Nalle mesh has greater dirt capacity than Colback 50.

One of the major limiting factors on the life of a filter is the dirt capacity of the filter element of the filter. When the filter element becomes loaded with dirt, it is usually necessary to replace the filter. Frequent replacement of a filter is uneconomical due to both the cost of the filter and the cost of the labor involved in its replacement.

The present inventors discovered that if a pleated filter element is enveloped in a wrap member having openings, the dirt capacity of the filter element can be greatly increased compared to that of an unwrapped pleated filter element or compared to that of a pleated filter element completely enveloped in a wrap member.

There may be several reasons why the dirt capacity is increased. The wrap member may help to maintain the spacing between adjacent pleats of the filter element. For example, in a clean, unwrapped filter, a flow drag force on the apexes of the pleats can cause some of the adjacent pleats to pinch together. This reduces the effective surface area and therefore the useful life of the filter. By providing the filter with a wrap member which is joined to the peaks of the pleated filter element, adjacent pleats are restrained from pinching

together. By providing the wrap member in combination with the polymeric bead spacers, the pleats are restrained even further. Therefore, the effective surface area of the filter is maximized and the useful life is significantly increased.

A wrap member also restrains movement of the pleats of a filter element when subjected to cyclic pressure fluctuations. As a result, abrasion caused by movement of the pleats is decreased, and the life span of the filter element is further increased.

In addition, the wrap member may produce a more uniform flow distribution over the length of the filter. In an unwrapped filter, flow through the filter element can be uneven. For example, when a filter element is enclosed in a housing, flow through the filter element may be greatest in the area closest to the inlet of the filter housing. Uneven flow causes dirt to be unevenly deposited on the filter element, and the uneven distribution can reduce the useful life of the filter. By providing the filter with a wrap member having openings, the flow can be distributed more evenly along the filter element, increasing the useful life of the filter.

The results produced by a wrap member are striking. For example, a filter element wound with the wrap member is expected to have a dirt capacity about 10% to 20% higher than the dirt capacity of a similar unwrapped filter element.

The wrap member also helps a filter element to

resist radially outwardly directed forces ~~and~~ prevent the filter element from swelling outward during pressure fluctuations in which the filter element is momentarily subjected to a negative  
5 differential pressure.

Figure 1 illustrates an example of the use of a wrap member with a filter. In the embodiment of Figure 1, the filter 10 is equipped with a wrap member 30 wrapped around the filter element 20 and  
10 having openings formed therein for the passage of fluid. In this embodiment, the wrap member 30 is a parallel-sided strip 31 of flexible material which is spirally wrapped about the filter element 20 in a plurality of turns. The spiral turns have a pitch  
15 greater than the width of the strip 31 so the openings in the wrap member comprise a spiral gap 32 between adjacent turns. The spiral strip 31 may be made of any suitable material which is compatible with the fluid the being filtered. Since much of  
20 the fluid being filtered reaches the filter element through the openings in the wrap member, the wrap member need not be permeable to the fluid, although in a preferred embodiment it is permeable. For many applications, a porous, polymeric, nonwoven material  
25 available from Reemay Corporation under the trade designation Reemay is suitable. Laminates of the Reemay material can also be employed. Examples of other suitable materials are oil board paper and mylar film. The material can be selected in

accordance with the desired reverse flow strength of the filter element.

The spiral strip 31 can be secured to the outer surface of the filter element 20 by any suitable means. One means of attaching the spiral strip 31 to the filter element 20 is by a bonding agent, such as a hot melt adhesive, which is applied to the strip 31 as it is wound around the filter element 20. The bonding agent 33 can be applied to the strip 31 in the form of a continuous or intermittent bead which spirals around the filter element 20 parallel to the edges of the strip 31. Alternatively, the strip 31 may be fusion bonded to the filter element 20 by a hot wheel which travels down the filter as the filter rotates.

The openings of the wrap member are preferably distributed uniformly along the filter element 20, although a nonuniform distribution may be used. To prevent the wrap member from becoming loaded, the size of the openings should be large enough to allow the passage of virtually all of the particles contained in the fluid being filtered. Furthermore, the total area of the openings is generally less than 50% of the total surface area of the surface defined by the peaks of the pleats, e.g., the cylinder circumscribing the peaks of the pleats of the illustrated filter element. More preferably the total area of the openings is in the range from about 6% to about 30% of the total area of the

surface defined by the peaks of the pleats. For example, in one embodiment, the filter element has an 11.4 centimeter (4.5 inch) outer diameter and a 22.25 centimeter (8.75 inch) length, the spiral strip 31 has a 3.8 centimeter (1.5 inch) width, and the spiral gap 32 between adjacent turns has a 6.35 millimeter (0.25 inch) width.

The filter 10 of Figure 1 can be manufactured in any suitable manner. For example, a composite filter element 20 having a standard axial length typically 1.07 meters (42 inches) can be formed using a corrugator in substantially the same manner as described previously. The core 11 is then inserted into the filter element 20 and the assembly is mounted on a mandrel. While the filter element is rotated on the mandrel, a spiral strip 31 is wrapped around the filter element 20 so as to leave a gap 32 of a desired size between turns. As the strip 31 is wrapped around the filter element 20, a hot melt adhesive 33 is applied to the inner surface of either the strip 31, the outer surface of the filter element 20, or both to bond the strip 31 to the filter element 20. Alternatively, a hot wheel may be run along an edge of the strip to fuse the strip to the peaks of the pleats. The wrapped filter element 20 is then cut to a suitable length and the end caps 12 and 13 are fitted over the ends of the filter element 20 and the spiral strip 31. The flanges of the end caps 12 and 13 fit over the

ends of the spiral strip 31 and prevent it from  
unwinding.

Figure 6 illustrates another embodiment. The  
embodiment has a wrap member 40 in the form of a  
5 spiral strip 41 having openings in the form of  
perforations 44 formed in the strip 41 itself.  
These perforations 44 serve the same function as the  
spiral gap 32 of the embodiment of Figure 1 and  
increase the dirt capacity of the filter element 20.  
10 The perforations 44 are preferably formed in the  
spiral strip 41 prior to its being wrapped around  
the filter element 20, since punching the  
perforations 44 in the strip 41 after wrapping could  
damage the filter element 20. The adjacent turns of  
15 the perforated spiral strip 41 can be separated from  
one another by a spiral gap, as in the embodiment of  
Figure 1, so the openings comprise both the  
perforations and the spiral gap. However, the wrap  
member 40 may have greater strength if the edges of  
20 adjacent turns partially overlap one another, as  
shown in Figure 6. The spiral strip 41 has a first  
edge 42 and a second edge 43. The first edge 42 may  
be bonded directly to the filter element 20 with a  
bonding agent 45, while the second edge 42 may  
25 overlap and be bonded to the first edge 43 of the  
adjacent turn of the strip 41. The structure of  
this embodiment is otherwise substantially the same  
as that of the embodiment of Figure 1.

The wrap member need not be wrapped spirally

around the filter element 20. Figure 7 is an elevation of another embodiment having a wrap member comprising a plurality of strips 51 of a flexible material which are wrapped circumferentially around the filter element 20 in a plurality of parallel turns. Adjacent turns of the strips 51 are separated from one another by circumferentially-extending gaps 52 which comprise the openings. The ends of each strip 51 overlap and are bonded to one another, and the strips 51 can also be attached to the filter element 20 by bonding. The circumferentially-extending gaps 52 of this embodiment function in the same manner as the spiral gap 32 of Figure 1 and increase the dirt capacity of the filter element 20. Although a wrap member 50 with circumferentially extending strips 51 is effective for increasing the dirt capacity of the filter, such a filter is more complicated to manufacture than a filter having a spiral wrap member, and therefore a filter with a spiral wrap member is generally more economical than one of the type illustrated in Figure 7.

The embodiments of Figures 1 and 6 employ only a single spiral strip to form the wrap member. Figure 8 illustrates another embodiment which differs from the embodiment of Figure 1 in that it has a wrap member 60 which comprises two strips 61 and 62 which are spirally wound around the filter element 20 in parallel, with each strip forming a

plurality of turns. The strips are separated by spiral gaps 63 which comprise the openings 61. The structure of this embodiment is otherwise the same as that of the embodiment of Figure 1. There is no  
5 limit on the number of strips which can constitute the spiral wrap.

Figure 9 illustrates another embodiment having a wrap member 70 in the form of a strip 71 of mesh which is wrapped spirally around a filter element.  
10 In this embodiment, the openings in the wrap member 70 are constituted by the mesh openings 72. The size of the mesh will depend upon the properties of the fluid being filtered, the flow rate, and other factors, but a mesh with a mesh size of about 12  
15 counts per centimeter (about 30 counts per inch) is generally satisfactory. The material which is used for the mesh will depend on the type of fluid being treated. Examples of suitable types of mesh are a knitted sock or a polymeric mesh. A polymeric mesh  
20 has the advantage that it can be directly connected to the filter element 20 by fusion bonding without the need for an adhesive. The structure of this embodiment is otherwise the same as that of the embodiment of Figure 1.

25 In the exemplary embodiments, the filter element is intended for use with outside-in radial fluid flow. However, if the positions of the upstream and downstream support and drainage layers 21 and 24, the cushioning layer 22, and the

polymeric beads 25 with respect to the filter layer 23 are switched, the filter element can be used for inside-out radial flow. In a filter element for inside-out radial flow, the upstream support and drainage layer would extend along the inner surface of the filter layer 23 (the surface closest to the radial center of the filter), the cushioning layer would be positioned between the upstream support and drainage layer and the filter layer, and the downstream support and drainage layer would extend along the outer surface of the filter layer 23 with the polymeric beads 25 adhered to the outer surface of the downstream support and drainage layer rather than to the inner surface.

The embodiments of the invention in which an exclusive property or privilege is claimed are defined as follows:

1. A filter comprising:  
a pleated filter element including longitudinally extending pleats having peaks; and  
a wrap comprising one or more strips of material each spirally wrapped around the filter element in one or more turns and joined to the peaks of the pleats, the total area of openings in the one or more strips and/or between adjacent turns of the one or more strips being less than about one-half of the total area of the surface of the whole tubular envelope defined by the peaks of the pleats.

2. The filter as claimed in claim 1, wherein the wrap comprises a strip of material spirally wrapped around the filter element in a plurality of turns and the openings comprise a spiral gap between adjacent turns.

3. The filter as claimed in claim 1, wherein the openings comprise holes formed in at least one of the one or more strips of material.

4. The filter as claimed in claim 3, wherein the one or more strips are wound around the filter in a plurality of turns and the edges of adjoining turns overlap one another.

5. The filter as claimed in claim 3, wherein the one or more strips are wound around the filter in a plurality of turns and the openings further comprise a spiral gap between adjacent turns.

6. The filter as claimed in claim 1, wherein the wrap comprises a plurality of strips of material wound

spirally around the filter element and wherein the openings comprise spiral gaps between adjacent strips.

7. The filter as claimed in claim 1, wherein the wrap comprises a mesh which is spirally wrapped around the filter element.

8. The filter as claimed in any one of claims 1 to 7, wherein the wrap comprises a porous material.

9. The filter as claimed in any one of claims 1 to 8, wherein the area of the openings in the wrap is in the range from 6% to 30% of the total area of the surface of the whole tubular envelope defined by the peaks of the pleats.

10. The filter as claimed in any one of claims 1 to 9, wherein the filter element comprises a composite including a filter layer, a support and drainage layer on the upstream side of the filter layer, and polymeric bead spacers on the downstream surfaces of the pleats.

11. The filter as claimed in claim 10, further comprising a cushioning layer disposed between the upstream support and drainage layer and the filter layer, and comprising a material which is smoother than the upstream support and drainage layer.

12. The filter as claimed in any one of claims 1 to 9, wherein the filter element comprises a pleated composite having a filter layer, a support and drainage layer, and means disposed between the filter layer and the support and drainage layer for resisting abrasion of the filter layer by the support and drainage layer.

13. The filter as claimed in claim 12, wherein the abrasion resisting means includes a cushioning layer comprising a material which is smoother than the support and drainage layer.

14. The filter as claimed in claim 13, wherein the cushioning layer comprises a smooth, porous non-woven material.

15. The filter as claimed in claim 13 or 14, wherein the material comprises a nylon or polyester.

16. The filter as claimed in any one of claims 13 to 15, wherein the material comprises a polyester non-woven material available from Hirose Corporation under the trade designation O5TH08.

17. The filter as claimed in any one of claims 13 to 15, wherein the material comprises a polyester non-woven material available from Reemay Corporation.

18. The filter as claimed in any one of claims 1 to 9, wherein the filter element comprises a pleated composite including first and second extruded polymeric mesh layers and a filtering layer positioned between them.

19. The filter as claimed in claim 18, wherein the pleated composite further includes a first cushioning layer positioned between the first mesh layer and the filtering layer.

20. The filter as claimed in claim 19, wherein the pleated composite further includes a second cushioning layer positioned between the second mesh layer and the filtering layer.

21. The filter as claimed in any one of claims 1 to 9, wherein the filter element comprises a pleated composite including an extruded polymeric mesh layer and a filtering layer.

22. The filter as claimed in claim 21, wherein the filtering layer has an upstream side and the mesh layer is positioned along the upstream side of the filtering layer.

23. The filter as claimed in claim 21, wherein the filtering layer has a downstream side and the mesh layer is positioned along the downstream side of the filtering layer.

24. The filter as claimed in claim 21, 22, or 23, wherein the pleated composite further comprises a cushioning layer between the mesh layer and the filtering layer.

25. The filter as claimed in any one of claims 18 to 24, wherein each mesh layer is in the range from 0.25 to 0.64 millimeters (0.010 to 0.025 inches) thick.

26. The filter as claimed in any one of claims 18 to 25, wherein for each mesh layer the number of strands in the x and y directions is in the range from 4 to 12 per centimeter (10 to 30 per inch).

27. The filter as claimed in any one of claims 18 to 26, wherein each polymeric mesh layer comprises polyester, polypropylene, or polyamide.

1 / 5

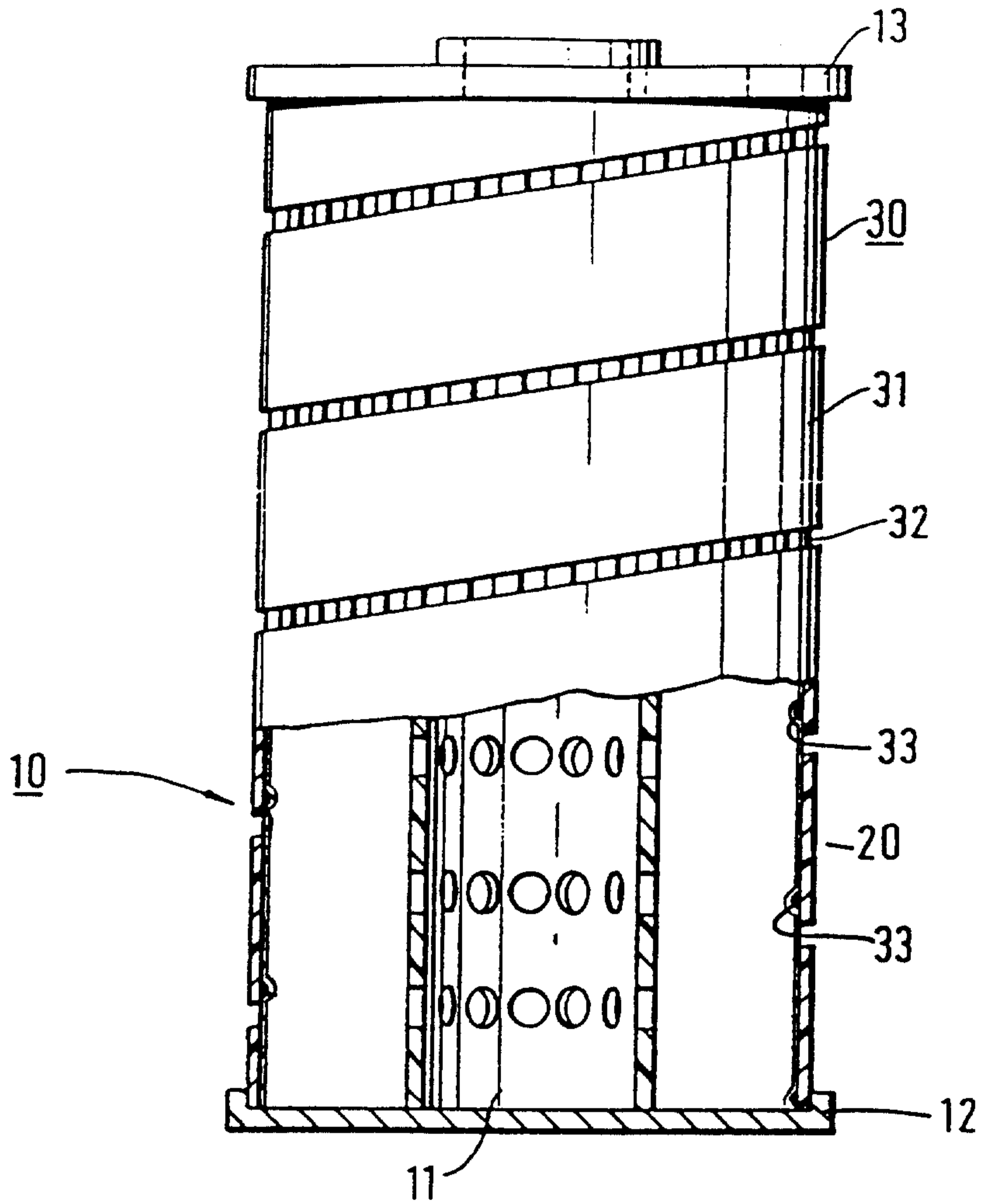
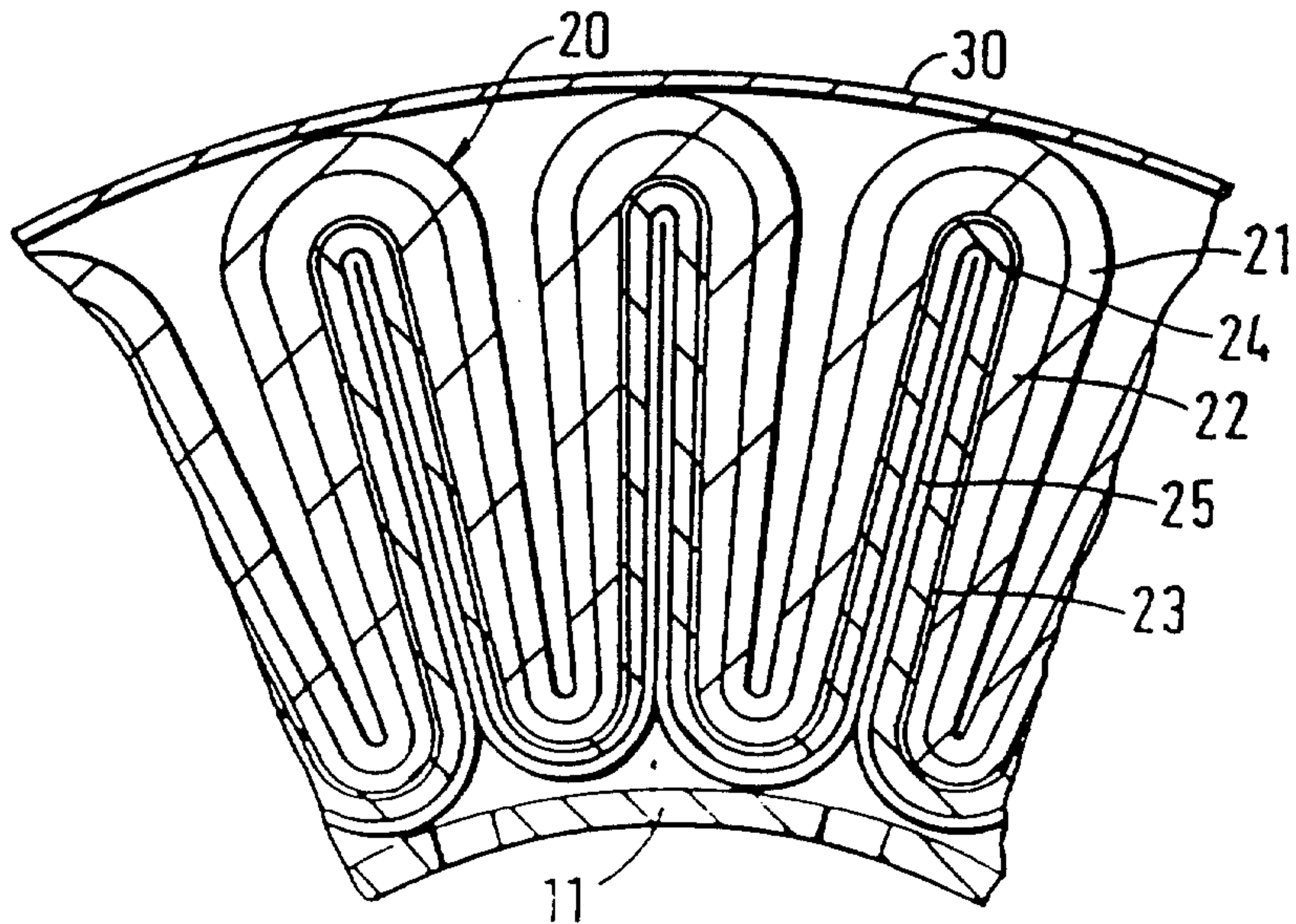

FIG. 1

FIG. 2



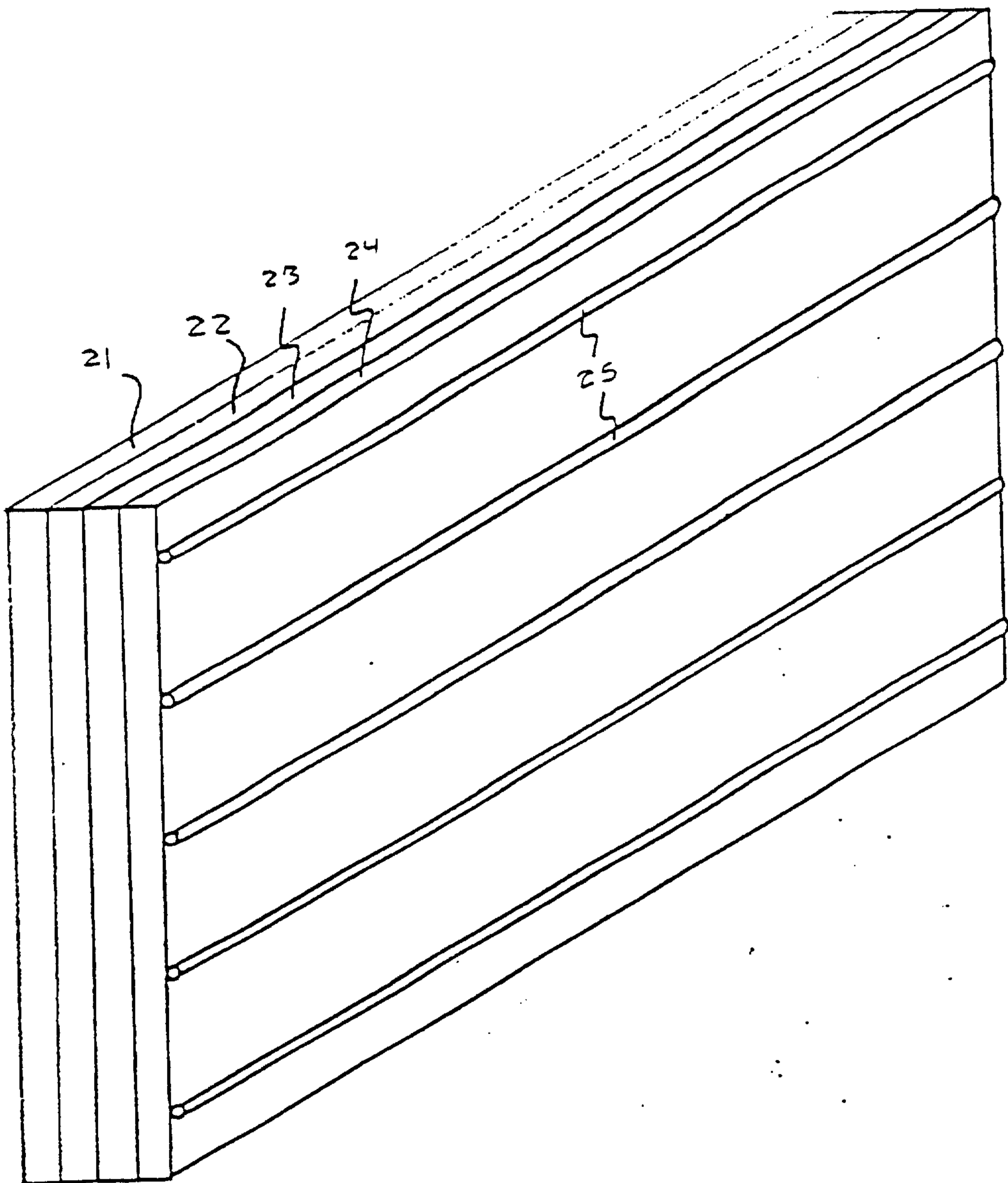

FIG 3

FIG 4

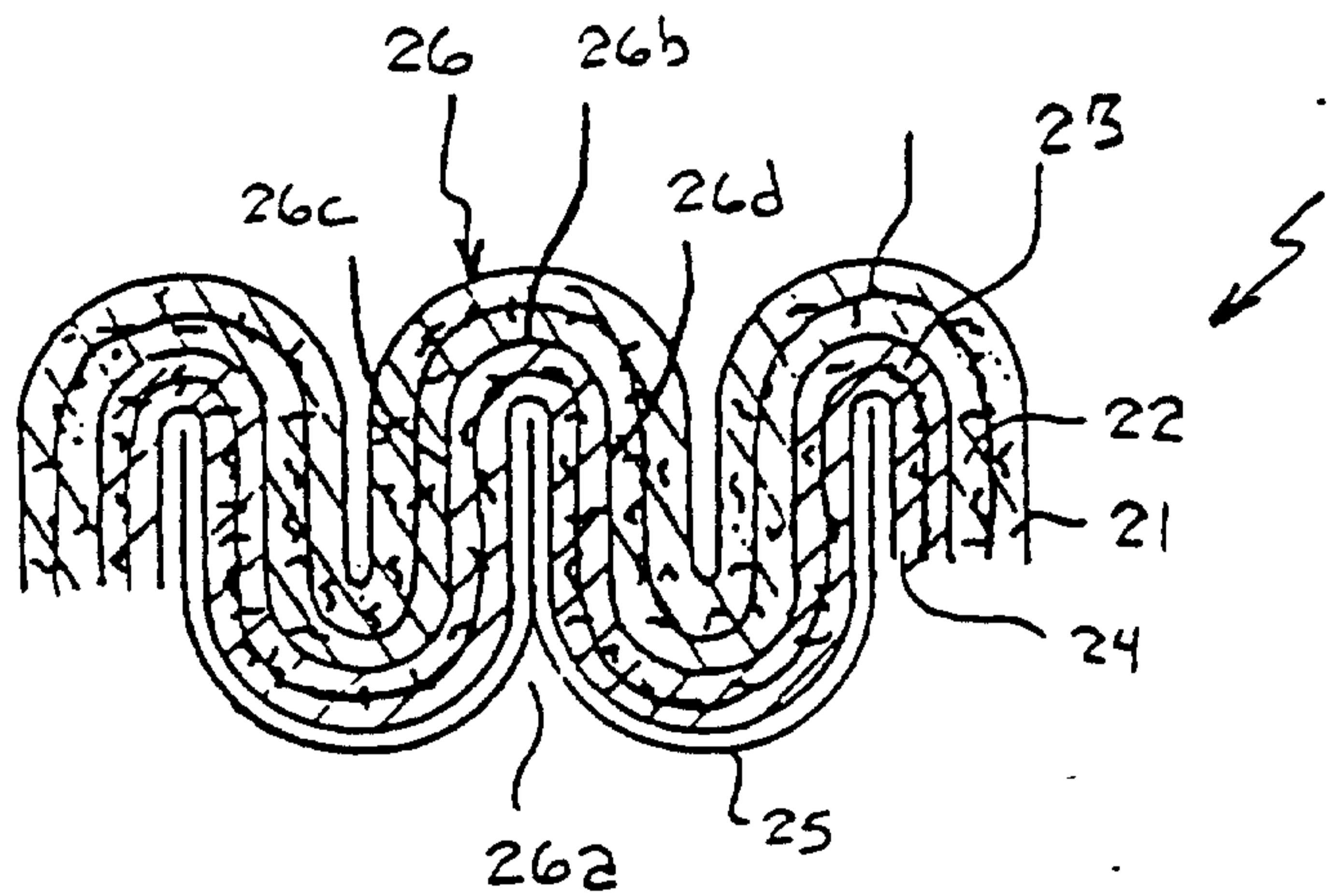
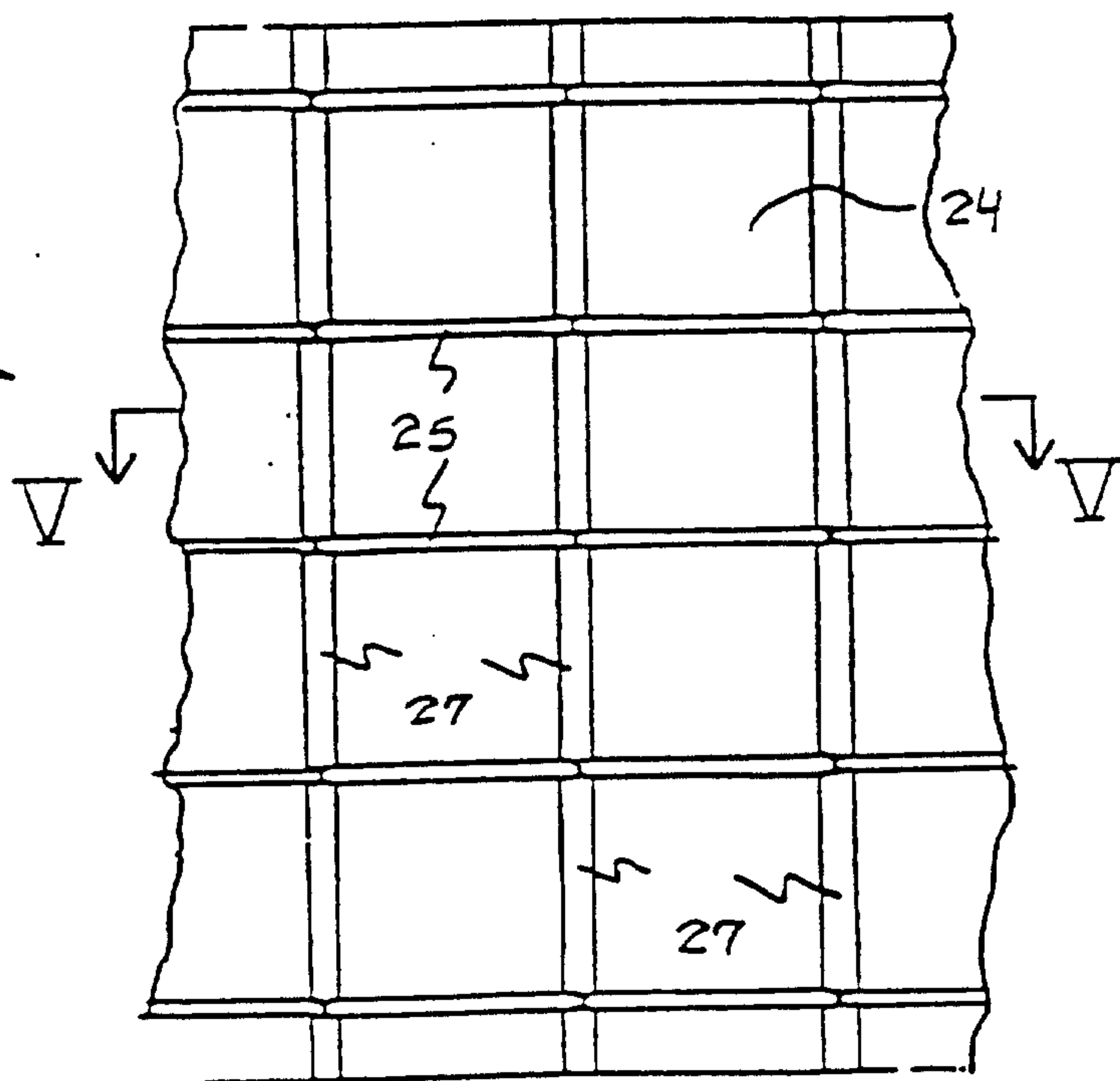

FIG 5



Heck & Clark

FIG 6

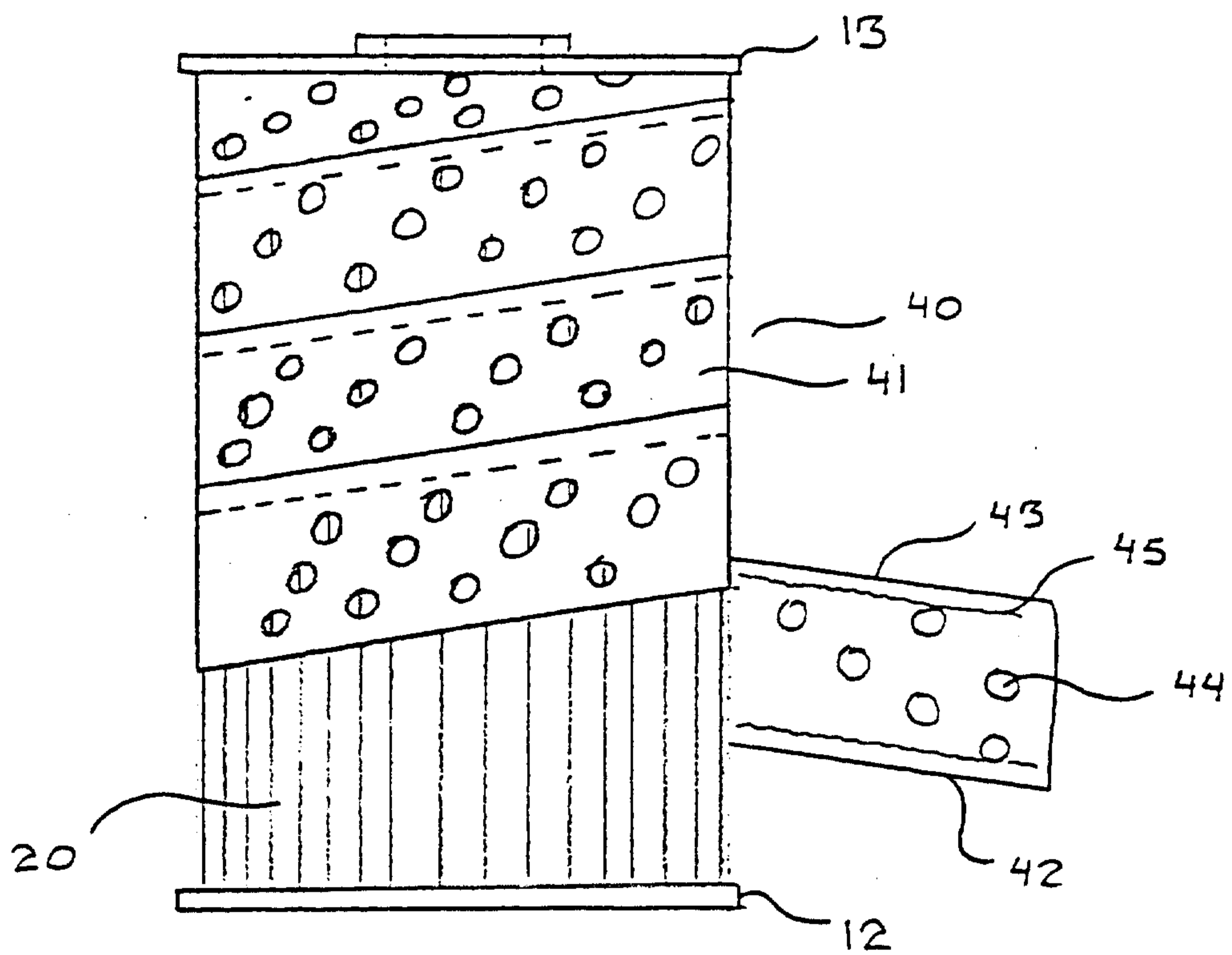
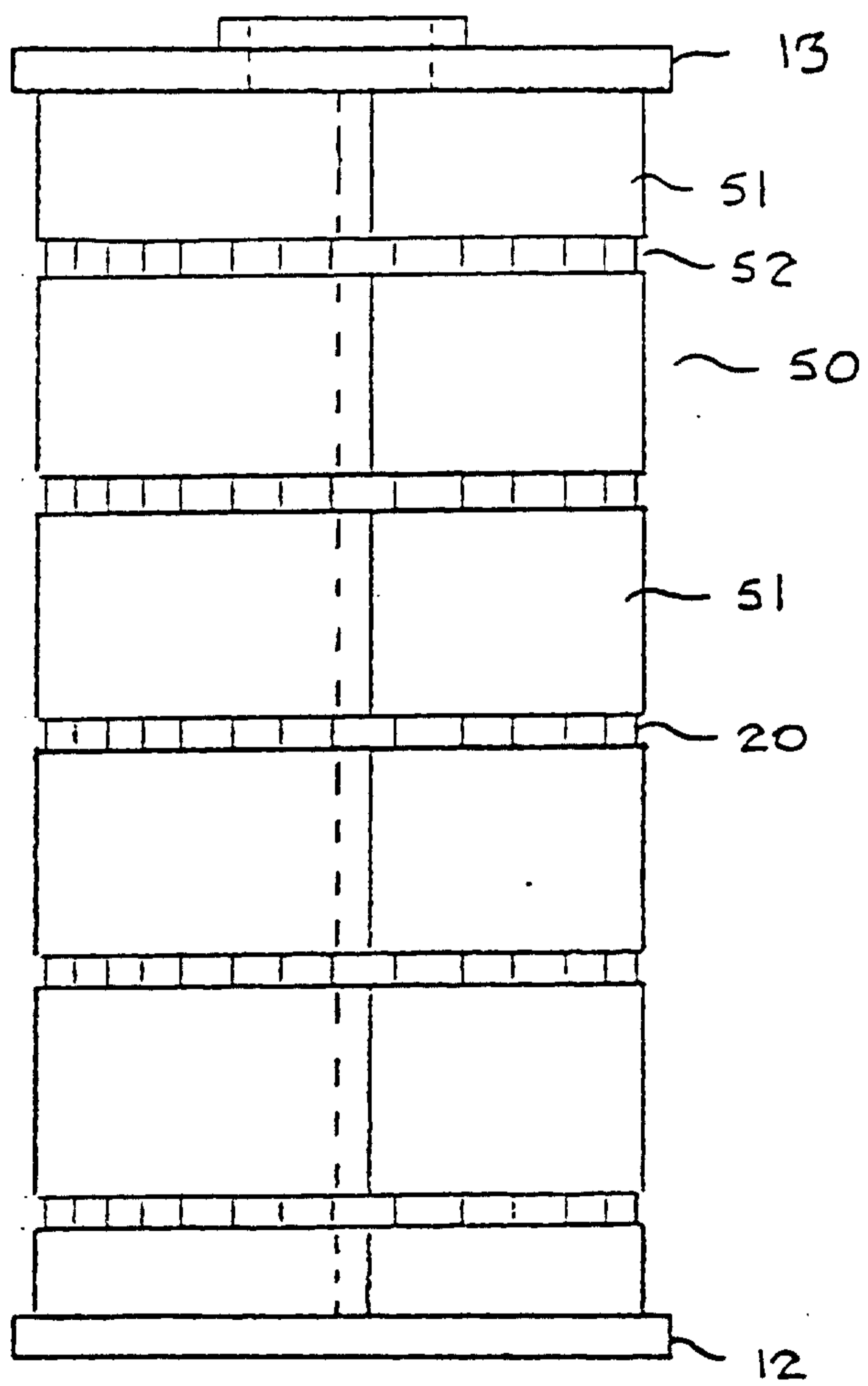
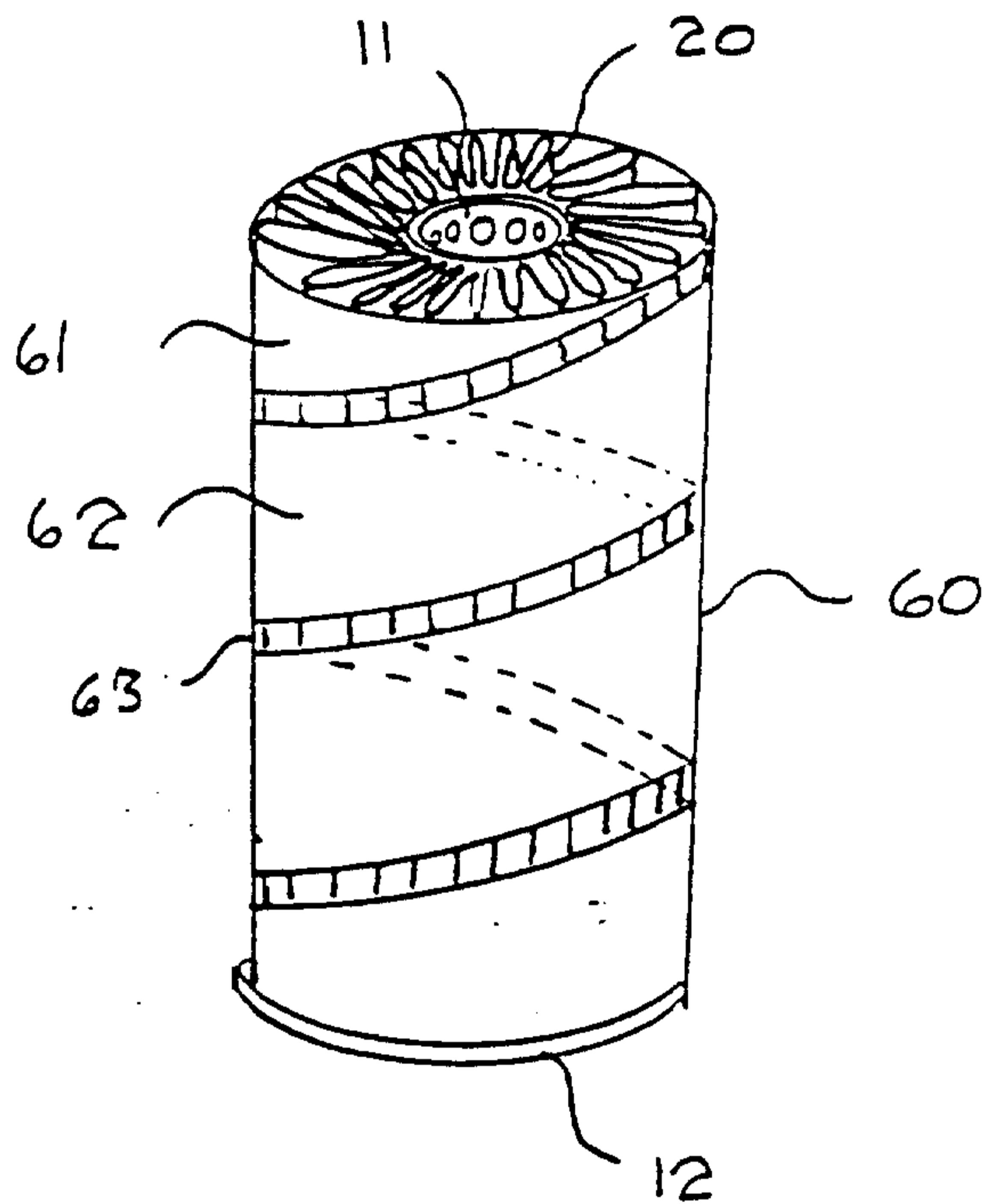

FIG 7



*Frank & Clark*

FIG 8



Shank & Clark

FIG 9

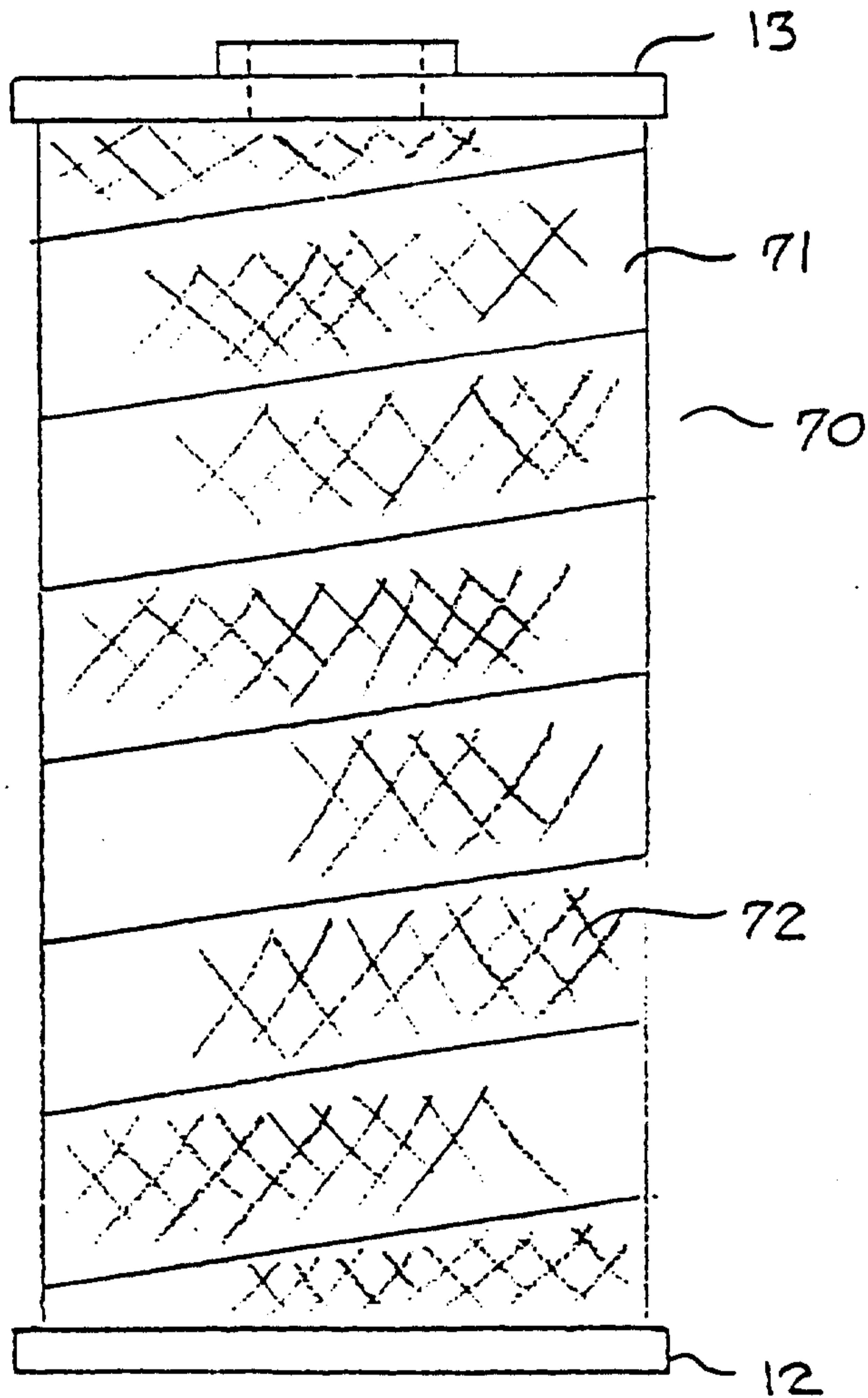

*Archie & Clerk*