

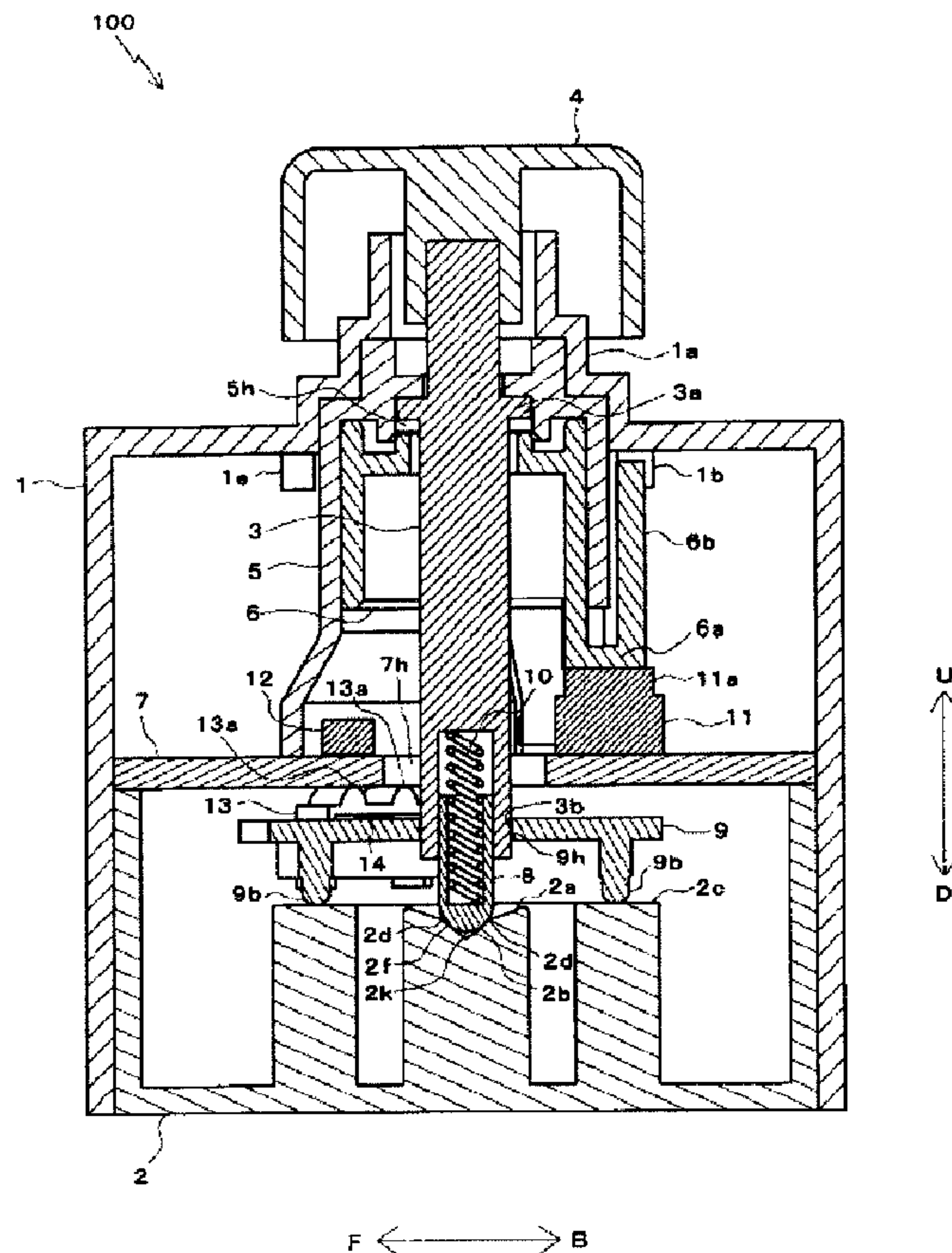

(22) Date de dépôt/Filing Date: 2006/03/21
 (41) Mise à la disp. pub./Open to Public Insp.: 2007/03/20
 (45) Date de délivrance/Issue Date: 2008/04/29
 (30) Priorité/Priority: 2005/09/20 (JP2005-272895)

(51) Cl.Int./Int.Cl. *B60R 1/07* (2006.01)
 (72) Inventeurs/Inventors:
 KAKUNO, HIDEYO, JP;
 KOYAMA, KATSUYA, JP;
 TOGAWA, SHINICHI, JP
 (73) Propriétaire/Owner:
 OMRON CORPORATION, JP
 (74) Agent: SMART & BIGGAR

(54) Titre : APPAREIL COMMUTATEUR
 (54) Title: SWITCHING APPARATUS



(57) Abrégé/Abstract:

The present invention provides a switching apparatus having excellent operability and simple structure while realizing different switching actions by pushing, rotating and rocking one operation knob. The switching apparatus comprises a case, an operation

(57) **Abrégé(suite)/Abstract(continued):**

shaft whose upper end projects from inside of the case and which is provided at its central portion with a flange, strikers which support the flange such that the operation shaft can rock and rotate, an operation knob mounted on an upper end of the operation shaft, and a substrate. A push switch is provided therein with a contact which is switched when the operation knob is pushed to move the operation shaft and the striker is moved. The push switch is mounted on the substrate. The substrate is formed with a fixed contact. When the operation knob is rotated to rotate the operation shaft, the slider rotates. In this rotating state, if the operation knob is rocked to rock the operation shaft, the slider moves and the fixed contact is switched.

ABSTRACT OF THE DISCLOSURE

The present invention provides a switching apparatus having excellent operability and simple structure while realizing different switching actions by pushing, rotating and rocking one operation knob. The switching apparatus comprises a case, an operation shaft whose upper end projects from inside of the case and which is provided at its central portion with a flange, strikers which support the flange such that the operation shaft can rock and rotate, an operation knob mounted on an upper end of the operation shaft, and a substrate. A push switch is provided therein with a contact which is switched when the operation knob is pushed to move the operation shaft and the striker is moved. The push switch is mounted on the substrate. The substrate is formed with a fixed contact. When the operation knob is rotated to rotate the operation shaft, the slider rotates. In this rotating state, if the operation knob is rocked to rock the operation shaft, the slider moves and the fixed contact is switched.

78491-36

TITLE OF THE INVENTION

SWITCHING APPARATUS

BACKGROUND OF THE INVENTION

1. Field of the Invention

5 [0001] The present invention relates to switching apparatus having an operation knob which can be pushed, rotated and rocked.

2. Description of the relates art

[0002] A switching apparatus used for a power mirror
10 apparatus is disposed on an arm rest or a front panel of a driver's seat of an automobile. The power mirror apparatus electrically adjusts visual angles of left and right side mirrors and tilts the side mirror up and down. It is required that the switching apparatus can perform switching
15 action for tilting up or down the side mirror (switching action of electric connection state of contact), switching action for selecting one of the left and right side mirrors, and switching action for adjusting visual angle of the selected side mirror.

20 [0003] Some of the conventional switching apparatuses include an operation knob operated for switching a contact for tilting up/down the side mirror, an operation knob operated for switching a selection contact of the side mirror, and an operation knob operated for switching an
25 adjustment contact of the visual angle of the side mirror.

[0004] Further, as disclosed in Japanese Patent Application Laid-Open No.2005-44582 and Japanese Patent Application Laid-Open No.2004-134239, there is a switching

78491-36

apparatus having one operation knob which is rotated for switching the selecting contact of the side mirror and which is rocked for switching the adjustment contact of the visual angle of the side mirror. The switching apparatus disclosed
5 in Japanese Patent Application Laid-Open No.2005-44582 and Japanese Patent Application Laid-Open No.2004-134239 has a structure for providing the rotation operation and the rocking operation of the operation knob with a click feeling (operating feeling).

10 [0005] Further, as disclosed in Japanese Patent Application Laid-Open No.2001-291456, there is a switching apparatus having one operation knob which is pushed for switching the contact for tilting up/down the side mirror, and which is rotated for switching the selection contact of
15 the side mirror, and which is rocked for switching the adjustment contact of the visual angle of the side mirror. The switching apparatus disclosed in Japanese Patent Application Laid-Open No.2001-291456 has a structure for providing the rotation operation and the rocking operation
20 of the operation knob with a click feeling.

[0006] Further, Japanese Patent No.3033205 discloses a switching apparatus (joystick apparatus) for a vehicular audio set. This switching apparatus has one operation rod which is pushed, rotated and rocked for switching contact s
25 corresponding to a plurality of functions of the audio set. The switching apparatus disclosed in Japanese Patent No.3033205 has a structure for providing the rotation operation and the rocking operation of the operation rod with a click feeling.

30 [0007] According to the conventional switching apparatuses having the plurality of operation knobs,

78491-36

however, it is necessary to re-hold the operation knob which is to be operated according to the need and thus, it is troublesome to operate, and the operability is poor. In the switching apparatuses of Japanese Patent Application Laid-
5 Open No.2005-44582 and Japanese Patent Application Laid-Open No.2004-134239, the pushing operation of the operation knob is not taken into consideration, and the contact which is switched over by pushing the operation knob is not provided. In the switching apparatuses of Japanese Patent Application
10 Laid-Open No.2001-291456 and Japanese Patent No.3033205, since the plurality of members are respectively provided with the plurality of contacts, the number of parts is increased and the structure becomes complicated.

[0008] The present invention has been accomplished to
15 solve the above problem, and it is an object of the invention to provide a switching apparatus which has excellent operability and simple structure and which realizes different switching actions depending upon pushing, rotating and rocking operations of one operation knob.

20 SUMMARY OF THE INVENTION

[0009] A switching apparatus of the present invention comprises a case, an operation shaft whose one end outwardly projects from inside of the case and which is provided at its central portion with a flange, a support member which
25 supports the flange such that the operation shaft can rock and rotate, an operation knob mounted on one end of the operation shaft, a first contact which is switched when the operation knob is pushed to move the operation shaft and the support member is moved, a second contact which is switched
30 when the operation knob is rotated to rotate the operation shaft, a third contact which is switched when the operation

78491-36

knob is rocked to rock the operation shaft, and a substrate respectively having the first, second and third contacts.

[0010] With this structure, the first contact is switched by pushing the operation knob, the second contact is
5 switched by rotating the operation knob, and the third contact is switched by rocking the operation knob. Therefore, it is possible to realize different switching actions by pushing, rotating and rocking the one operation knob, and as compared with the conventional switching
10 apparatus provided with a plurality of operation knobs which are operated differently, the operability can remarkably be enhanced. Further, the first, second and third contacts are provided on the same substrate. Therefore, as compared with the switching apparatuses disclosed in Japanese Patent
15 Application Laid-Open No.2001-291456 and Japanese Patent No.3033205 in which the plurality of contacts are provided on the plurality of members separately, the number of parts can be reduced and the structure can be simplified. Further, the switching apparatus can be reduced in size in
20 the height direction.

[0011] In an embodiment of the invention, the substrate is provided at its one of surfaces with the first contact, and at its other surface with the second and third contacts.

[0012] With this structure, it is easy to dispose the
25 contacts on the substrate as compared with the switching apparatuses disclosed in Japanese Patent Application Laid-Open No.2001-291456 and Japanese Patent No.3033205 in which all of the contacts are provided on the upper surface of the substrate, and the substrate can be reduced in size, and the
30 switching apparatus can be reduced in size in its width direction. The substrate may be provided at its one surface

78491-36

with the space in which a part for switching the first contact moves in the height direction, and may be provided at its other surface with the space in which parts for switching the second and third contacts move in the width
5 direction. Therefore, it becomes easy to secure each moving space as compared with the switching apparatus disclosed in Japanese Patent No.3033205 in which the upper surface of the substrate is provided with the moving space for all of parts for switching the contacts, and it is possible to reduce the
10 switching apparatus in the height direction and width direction.

[0013] According to an embodiment of the invention, the first contact is provided in a push switch having an actuator which is mounted on the surface of the substrate on
15 the side of the operation knob and which can be pushed, the actuator is switched if the actuator is pushed by the support member.

[0014] With this structure, it is easier to dispose the first contact and the number of parts required for switching
20 the first contact is smaller, and the structure of the switching apparatus can further be simplified as compared with the switching apparatus as disclosed in Japanese Patent Application Laid-Open No.2001-291456 in which the fixed contact and the movable contact are provided separately as
25 contacts which are switched by pushing the operation knob.

[0015] According to an embodiment of the invention, the switching apparatus further comprises a movable contact which can follow the operation shaft and rotate and which can move in parallel to the substrate in a state in which
30 the movable contact is in contact with the substrate on the substrate on the opposite side from the operation knob,

78491-36

wherein the second and third contacts are fixed contacts formed on the surface of the substrate opposite from the operation knob, when the operation shaft is rotated, the movable contact rotates to switch the second contact, and
5 when the operation shaft is rocked, the movable contact moves in parallel to the substrate to switch the third contact.

[0016] With this structure, since the second and third contacts are switched by the same movable contact, the
10 number of parts required for switching the second and third contacts is smaller than those of the switching apparatuses as disclosed in Japanese Patent Application Laid-Open No.2005-44582 and Japanese Patent Application Laid-Open No.2004-134239 in which the contact which is switched by
15 rotating the operation knob and the contact which is switched by rocking the operation knob are switched by separate movable contacts, and the structure of the switching apparatus can further be simplified. Since the movable contact and the second and third contacts are
20 provided on the same surface of the substrate, the switching structure of the second and third contacts can further be simplified as compared with the switching apparatuses disclosed in Japanese Patent Application Laid-Open No.2005-44582 to Japanese Patent Application Laid-Open No.2001-
25 291456 in which the movable contact is provided on the lower surface of the substrate and the fixed contact is provided on the upper surface of the substrate.

[0017] According to the present invention, the first, second and third contacts provided on a substrate are
30 switched over by pushing, rotating and rocking the operation knob. Therefore, it is possible to realize different

78491-36

switching actions depending upon pushing, rotating and rocking operations of the one operation knob, the operability can be enhanced and the structure can be simplified.

5 BRIEF DESCRIPTION OF THE DRAWINGS

[0018] FIG. 1 shows an exploded perspective view of a switching apparatus according to an embodiment of the present invention;

10 FIGS. 2 show an outward appearance view of the switching apparatus;

FIG. 3 shows a perspective view of the switching apparatus;

FIGS. 4 show a perspective view of the switching apparatus;

15 FIG. 5 shows a side view of the switching apparatus;

FIGS. 6 show a substrate and a slider of the switching apparatus;

20 FIG. 7A shows a sectional view of the switching apparatus taken along the line Z-Z in FIG. 2;

FIG. 7B shows a sectional view of the switching apparatus taken along the line Z-Z in FIG. 2;

FIG. 7C shows a sectional view of the switching apparatus taken along the line Z-Z in FIG. 2;

25 FIG. 7D shows a sectional view of the switching apparatus taken along the line Z-Z in FIG. 2;

78491-36

FIGS. 8 show a sectional view of the switching apparatus taken along the line Y-Y in FIG. 2;

FIG. 9 shows a sectional view of the switching apparatus taken along the line X-X in FIG. 2; and

5 FIG. 10 shows a sectional view of the slider of the switching apparatus.

DETAILED DESCRIPTION OF THE PREFERRED EMBODIMENTS

[0019] FIG. 1 is an exploded perspective view of a switching apparatus 100 according to an embodiment of the present invention. The switching apparatus 100 is used for a power mirror apparatus which electrically adjust a visual angle of vehicular left and right side mirrors, and tilts up and down the side mirrors. As shown in FIG. 1, the switching apparatus 100 mainly comprises a case 1, a cover 2, an operation shaft 3, an operation knob 4, an outer 10 striker 5, an inner striker 6, a substrate 7, a plunger 8 and a slider 9.

[0020] FIGS. 2 to 10 show an assembled state of the switching apparatus 100. Specifically, FIGS. 2 show an outward appearance view of the switching apparatus 100, FIG. 2A shows a plan view, FIG. 2B shows a left side view and FIG. 2C shows a rear side view. FIGS. 3 and 4 are perspective views of the switching apparatus 100. In FIG. 3, a portion of the case 1 is omitted, and in FIGS. 4, 25 the case 1 and the cover 2 are omitted. FIG. 5 shows a side view of the switching apparatus 100, and the case 1, the cover 2 and a first striker 5 are omitted. FIGS. 6 show the substrate 7 and the slider 9, and show the substrate 7 as viewed from its lower surface. FIGS. 7A to 7D show sectional views of the switching apparatus 100 taken along 30

78491-36

the line Z-Z in FIG. 2. FIGS. 8 show sectional views of the switching apparatus 100 taken along the line Y-Y in FIG. 2. FIG. 9 shows a sectional view of the switching apparatus 100 taken along the line X-X in FIG. 2. FIG. 10 shows a
5 sectional view of the slider 9, and shows a cross section perpendicular to a cross section of FIG. 7B as viewed from left.

[0021] As shown in FIG. 7A, a lower portion of the case 1 is opened. The lower portion of the case 1 is closed by
10 fitting a cover 2 thereinto. The case 1 is integrally provided at its upper surface with a cylinder 1a which is vertically opened and is in communication with the case 1. Inner and outer diameters of the cylinder 1a are reduced toward its upper portion in stages. An operation shaft 3 is
15 provided in the case 1 and the cylinder 1a. An upper end of the operation shaft 3 penetrates the cylinder 1a from inside of the case 1 and projects outward. The operation knob 4 is mounted on the upper end such as to cover the upper opening of the cylinder 1a. In this mounting state, a gap is formed
20 between the operation knob 4 and the cylinder 1a.

Therefore, the operation knob 4 can be pushed downward D as shown with the arrows in FIGS. 2, the operation knob 4 can be rotated in the clockwise direction P and the counterclockwise direction Q, and can be rocked forward F,
25 rearward B, rightward R and leftward L. The operation shaft 3 can move in the axial direction (dotted line in FIG. 1) to follow the operation knob 4, rotate around the axial direction and can rock.

[0022] The plunger 8 having a semi-spherical tip end as
30 shown in FIG. 7A and the like is mounted on the operation shaft 3 such that the plunger 8 can move in the axial

78491-36

direction of the operation shaft 3. A coil spring 10 is interposed between the operation shaft 3 and the plunger 8. The coil spring 10 adds elastic force acting on the operation shaft 3 and the plunger 8 such that the operation shaft 3 and the plunger 8 are separated from each other in the axial direction. The cover 2 is integrally provided with a guide pedestal 2a below the plunger 8. The guide pedestal 2a engages with the end of the plunger 8 to guide the movement of a lower end of the operation shaft 3 through the plunger 8 when the operation shaft 3 is rocked. A recess 2k is formed in a central portion of an upper portion of the guide pedestal 2a. As shown in FIGS. 7A and 9, oblique surfaces 2f, 2b, 2l, 2r are provided around the recess 2k. The oblique surfaces 2f, 2b, 2l, 2r rise into four directions, i.e., forward, backward, leftward and rightward from the recess 2k in which the operation knob 4 and the operation shaft 3 can rock. A convex portion 2d comprising a step having an obtuse angle is provided on intermediate portions of the oblique surfaces 2f, 2b, 2l, 2r. The recess 2k and the convex portion 2d are provided in parallel in a direction (rocking direction of the operation shaft 3) in which lower ends of the plunger 8 and the operation shaft 3 are guided. The plunger 8 is biased downward by the coil spring 10, and is pushed against the guide pedestal 2a. The operation shaft 3 is biased upward by the coil spring 10 and is pushed against the outer striker 5.

[0023] The operation shaft 3 is provided at its central portion with a polygonal (octagonal) flange 3a as shown in FIG. 1. The operation shaft 3 is inserted into the outer striker 5 from its lower side, and the inner striker 6 is inserted into the outer striker 5 from its lower side such

78491-36

as to penetrate the operation shaft 3. With this, as shown in FIG. 7A and the like, the flange 3a of the operation shaft 3 is sandwiched and supported between the outer striker 5 and the inner striker 6. In this supporting state, a gap is formed between the operation shaft 3 and the strikers 5 and 6. Therefore, the operation shaft 3 can follow the operation knob 4 and rock and rotate. A space 5h of the outer striker 5 accommodating the flange 3a has the same shape and substantially the same size as the flange 3a and is formed into polygonal (octagonal) shape. Therefore, the outer striker 5 can follow the operation shaft 3 and rotate. A lower end of the inner striker 6 is provided with a pressing portion 6a which projects such as to penetrate a notch 5k provided in a lower end of the outer striker 5 as shown in FIGS. 1, 4 and 8. An extending portion 6b extending upward is provided on the pressing portion 6a at a predetermined distance from the outer striker 5. As shown in FIG. 8, an upper end of the extending portion 6b is fitted and held between two stoppers 1b which are integrally provided on the case 1. Therefore, the inner striker 6 can not rotate. The strikers 5 and 6 constitute an embodiment of a support member of the present invention.

[0024] A step-wise outer surface (an upper end surface, a step-wise surface and an outer peripheral surface) continuously extending from a central portion toward an upper end of the outer striker 5 is engaged with a step-wise inner surface (a step-wise surface and an inner peripheral surface) continuously extending from a central portion of an inner side toward a lower end of the cylinder 1a as shown in FIG. 7A. A lower end of the outer striker 5 is supported by the substrate 7. A side surface and a lower surface of the substrate 7 are supported by the case 1 and the cover 2.

78491-36

Thus, the outer striker 5 can not follow the operation shaft 3 and can not move vertically and laterally. The substrate 7 can not rotate, and can not vertically and laterally move. The operation shaft 3 penetrate a hole 7h formed in a central portion of the substrate 7. A diameter of the hole 7h is greater than that of the operation shaft 3 by a certain value and thus, the operation shaft 3 can move in the axial direction independently from the substrate 7, and can rotate and rock.

10 [0025] As shown in FIGS. 3 to 5 and 7A and the like, the pressing portion 6a of the inner striker 6 is placed on and supported by an actuator 11a of a push switch (surface mounting type tact switch) 11 mounted on an upper surface of the substrate 7. The push switch 11 is disposed in the vicinity of the operation shaft 3 below the inner striker 6 and in the notch 5k of the outer striker 5. Since the actuator 11a can be pushed into the push switch 11, the inner striker 6 can vertically move. The push switch 11 is provided therein with a known mechanism comprising a spring which biases the 11a from inside such as to project the same and which provides click feeling (operation feeling) when the actuator 11a is pushed in, or with a contact which is switched from OFF state (open, non-conductive state) to ON state (connect, conductive state) if the actuator 11a is pushed in. If the inner striker 6 follows the operation shaft 3 and moves downward, the actuator 11a of the push switch 11 is pushed by the pressing portion 6a of the inner striker 6, the inner contact of the push switch 11 is switched from the OFF state to the ON state. The inner contact of the push switch 11 outputs a command signal for tilting the side mirror up or down to a control unit (not shown) which control the operation of the side mirror. The

78491-36

inner contact constitutes an embodiment of a first contact in the invention.

[0026] On the upper surface of the substrate 7, an electronic component such as a light-emitting diode 12 is mounted in addition to the push switch 11. An electric circuit comprising the electronic component and wire pattern (not shown) is formed. The light-emitting diode 12 emits light to the operation knob 4 from below.

[0027] As shown in FIGS. 7B and 8, the outer striker 5 is provided at its upper outer peripheral surface with a projection 5e. The outer striker 5 is provided with two stoppers 1e such that the stoppers 1e are integral with the case 1. The projection 5e abuts against the stoppers 1e when the outer striker 5 follows the operation shaft 3 and rotates in the clockwise direction P or counterclockwise direction Q through a predetermined angle (45°). If the projection 5e abuts against the stoppers 1e, the outer striker 5, the operation shaft 3 and the operation knob 4 are prevented from excessively rotating more than predetermined angles.

[0028] As shown in FIGS. 3, 4 and 8, the outer striker 5 is provided with a lower outer peripheral surface with an engaging portion 5a comprising a projection having an arc tip end. Two guide walls 1c are provided on opposite sides of the engaging portion 5a such that the guide walls 1c are integrally formed with the case 1. The guide walls 1c engage with the engaging portion 5a to guide rotation of the outer striker 5 and movement of the engaging portion 5a when the operation shaft 3 is rotated. The guide walls 1c are warped in the opposite direction from the outer striker 5, the guide walls 1c are disposed on opposite sides of the

78491-36

engaging portion 5a in a V-form. A convex portion 1d and a recess 1k are formed in parallel to each other in the guide wall 1c in a direction in which the engaging portion 5a is guided (rotation direction of the outer striker 5). The
5 outer striker 5 and the guide wall 1c are made of synthetic resin. As shown in FIGS. 8A and 8B, when the engaging portion 5a is not in contact with the convex portion 1d, the guide wall 1c is not elastically deformed almost at all, the engaging portion 5a and the guide wall 1c are engaged with
10 each other under small pressure, and when the engaging portion 5a is in contact with the convex portion 1d, the guide wall 1c is elastically deformed and the engaging portion 5a and the guide wall 1c are engaged with each other under high pressure.

15 [0029] As shown in FIGS. 5, 10 and 7A, the slider 9 is provided below the substrate 7 (on the opposite side from the operation knob 4). Four legs 9b which are downwardly projecting bosses are formed on four corners of a lower surface of the slider 9. The legs 9b are supported on a
20 support base 2c integrally provided on the cover 2. Two terminals 13 are mounted between the legs 9b. As shown in FIG. 10, the terminals 13 are provided such that they can vertically move through the slider 9. Two upwardly projecting movable contacts 13a are formed on an upper
25 surface of each terminal 13. A coil spring 14 is interposed between the terminal 13 and the slider 9. The coil spring 14 upwardly biases the terminal 13, pushes the movable contact 13a against the lower surface of the substrate 7 under predetermined pressure, and biases the
30 slider 9 downwardly, and pushes the legs 9b against the support base 2c under predetermined pressure. That is, the slider 9 and the terminal 13 are sandwiched between the

78491-36

substrate 7 and the support base 2c, and the movable contact 13a is always in contact with the lower surface of the substrate 7. The operation shaft 3 penetrates a hole 9h formed in a center of the slider 9. As shown in FIG. 1, a penetrating portion 3b of the operation shaft 3 which penetrates a hole 9h is of polygonal (octagonal) shape, the hole 9h is formed into polygonal (octagonal) shape having the same shape and substantially the same size as those of the penetrating portion 3b. Therefore, the slider 9 and the movable contact 13a of the terminal 13 can follow the operation shaft 3 and can rotate and can move in parallel to the substrate 7. The support base 2c has such a size that the movable contact 13a does not fall from the support base 2c when moving.

[0030] As shown in FIG. 6, a plurality of fixed contacts 7pc, 7pr, 7pl, 7pu, 7pd, 7qc, 7qr, 7ql, 7qu, 7qd are formed on the lower surface of the substrate 7. The fixed contacts 7pc, 7pr, 7pl, 7pu, 7pd output signals for tilting the right side mirror vertically and laterally to the control unit. The fixed contacts 7qc, 7qr, 7ql, 7qu, 7qd output signals for tilting the left side mirror vertically and laterally to the control unit. The slider 9 follows the operation shaft 3 and rotates. With this, the movable contact 13a of the terminal 13 moves to a position close to the fixed contacts 7pc, 7pr, 7pl, 7pu, 7pd or close to the fixed contacts 7qc, 7qr, 7ql, 7qu, 7qd. The slider 9 follows the operation shaft 3 and moves to one of forward, backward, leftward and rightward directions in parallel to the substrate 7. With this, the movable contact 13a comes into contact with the fixed contacts 7pc, 7pr, 7pl, 7pu, 7pd, 7qc, 7qr, 7ql, 7qu, 7qd located in the moving direction, the fixed contacts are switched from the OFF state to ON state.

78491-36

The fixed contacts 7pc, 7pr, 7pl, 7pu, 7pd, 7qc, 7qr, 7ql, 7qu, 7qd constitute one embodiment of second and third contacts of the present invention.

[0031] Electronic components (not shown) are also mounted
5 on the lower surface of the substrate 7. An electric circuit comprising these electronic components and a wire pattern (not shown) is formed. Mounted on the switching apparatus 100 are connecting parts such as a connector and an electric wire (not shown) for outputting switching
10 signals of the fixed contacts 7pc, 7pr, 7pl, 7pu, 7pd, 7qc, 7qr, 7ql, 7qu, 7qd and the inner contact of the push switch 11 to the control unit by mounting them on the substrate 7.

[0032] In the above structure, when the operation knob 4 is not operated, the various portions are in the initial
15 state as shown in FIGS. 2, 3, 4A, 5, 6A, 7A, 8A and 9. If the operation knob 4 is once pushed downward D in FIG. 2 from this initial state, the operation shaft 3 downwardly moves as shown in FIG. 7D, and the flange 3a pushes the inner striker 6 downward. Thus, the actuator 11a of the
20 push switch 11 is pushed by the pressing portion 6a of the inner striker 6, and the inner contact of the push switch 11 is switched from the OFF state to the ON state. At that time, drag of the actuator 11a with respect to the pressing portion 6a is abruptly varied (once increased and then
25 reduced) by an internal mechanism of the push switch 11, and click feeling is provided through the inner striker 6, the operation shaft 3 and the operation knob 4. Thus, if a user operate the operation knob 4 by pushing the same while relying on the click feeling, the operation shaft 3 and the
30 inner striker 6 can be moved to an appropriate position (to a position where the pressing portion 6a of the inner

78491-36

striker 6 moves the actuator 11a of the push switch 11 downward by a stroke required for switching the inner contact). If the inner contact of the push switch 11 is switched, the switching signal is output from the switching apparatus 100 to the control unit as a signal for tilting up the side mirror, and the control unit which received the signal drives an electric motor such as a motor, thereby tilting up the left and right side mirrors.

[0033] If the pushing operation of the operation knob 4 is released, the operation shaft 3 is biased upward by the coil spring 10, and the flange 3a stops pushing the inner striker 6. Therefore, the actuator 11a of the push switch 11 is biased upward by the internal mechanism, the pressing portion 6a of the inner striker 6 is pushed up, and the inner contact of the push switch 11 is switched from the ON state to the OFF state. As shown in FIGS. 7A and 9, the operation shaft 3, the operation knob 4 and the inner striker 6 returned to their original positions. Then, if the operation knob 4 is again pushed, the inner contact of the push switch 11 is switched from the OFF state to the ON state, and this switching signal is output from the switching apparatus 100 to the control unit as a signal for tilting down the side mirror, and the control unit which received the signal drives the electric motor to tilt down the left and right side mirrors.

[0034] If the operation knob 4 is rotated in the counterclockwise direction Q shown in FIG. 2 from the initial state, the operation shaft 3 is rotated and the flange 3a rotates the outer striker 5 as shown in FIGS. 4B and 8B. At that time, the engaging portion 5a of the outer striker 5 climbs over the convex portion 1d from the

78491-36

recess 1k of the guide wall 1c. With this, the engagement force between the engaging portion 5a and the guide wall 1c is abruptly varied (once increased and then reduced), and the click feeling is provided through the outer striker 5, the operation shaft 3 and the operation knob 4. Therefore, if a user operate the operation knob 4 by rotating the same while relying on the click feeling, the operation shaft 3 and the outer striker 5 can be rotated to an appropriate position (to a position where the engaging portion 5a of the outer striker 5 rotates through 45° and climbs over the convex portion 1d of the guide wall 1c). The projection 5e abuts against the stoppers 1e as described above. With this, excessive rotation of the outer striker 5 beyond the appropriate position is limited. At the same time, the operation shaft 3 hitches the slider 9 with the penetrating portion 3b, and rotates the slider 9 and the terminal 13 in the counterclockwise direction Q through 45° as shown in FIGS. 6B and 7B. Therefore, the movable contact 13a of the terminal 13 moves to a position close to the fixed contacts 7qc, 7qr, 7ql, 7qu, 7qd, and the visual angle of the left side mirror can be adjusted (vertically and laterally tilted).

[0035] If the operation knob 4 is rocked forward F from the rotation state, the operation shaft 3 is rocked as shown in FIG. 7C, and the plunger 8 is upwardly moved along the oblique surface 2b of the guide pedestal 2a in a direction B opposite from the operating direction F of the operation knob 4. At that time, the plunger 8 climbs over the convex portion 2d from the recess 2k of the guide pedestal 2a and with this, the engagement force between the plunger 8 and the guide pedestal 2a is abruptly varied (once increased and then reduced), and click feeling is provided through the

78491-36

plunger 8, the operation shaft 3 and the operation knob 4. Therefore, if a user operate the operation knob 4 by rocking the same while relying on the click feeling, the operation shaft 3 can be rocked to an appropriate position (to a
5 position where the plunger 8 climbs over the convex portion 2d of the guide pedestal 2a). The flange 3a abuts against the upper and side surfaces of the space 5h of the outer striker 5. With this, excessive rotation of the operation shaft 3 beyond the appropriate position is
10 limited. At the same time, the operation shaft 3 hitches the slider 9 with the penetrating portion 3b, and moves the slider 9 and the terminal 13 in the direction B opposite from the operating direction F of the operation knob 4 in parallel to the substrate 7 as shown in FIGS. 7C and 6C.
15 Therefore, the two movable contacts 13a of the terminal 13 respectively come into contact with the two fixed contacts 7qc and 7qu located in the moving direction B, these fixed contacts 7qc and 7qu are connected to each other through the terminal 13, and the state is switched from the
20 OFF state to the ON state. This switching signal is output from the switching apparatus 100 to the control unit as a signal for tilting up the left side mirror, and the control unit which received this signal drives the electric motor to tilt up the left side mirror through a predetermined angle.

25 [0036] If the rocking operation of the operation knob 4 is released, the plunger 8 is downwardly biased by the coil spring 10, the plunger 8 moves downward along the oblique surface 2b of the guide pedestal 2a, and the plunger 8 returns to its position before the plunger 8 is fitted in
30 the recess 2k as shown in FIG. 7A. Further, the operation shaft 3 is biased upward by the coil spring 10, and pulled by the plunger 8 and rocked such as to be perpendicular to

78491-36

the substrate 7, and the operation shaft 3 returns to a position before the operation shaft 3 and the operation knob 4 rock as shown in FIG. 7A. At the same time, the slider 9 is pulled by the penetrating portion 3b of the operation shaft 3, and moves in parallel to the substrate 7, and returns to a position before the slider 9 and the terminal 13 rock as shown in FIG. 7A and 6B. Therefore, the movable contact 13a of the terminal 13 comes to an intermediate position of the fixed contacts 7qc, 7qr, 7ql, 7qu, 7qd, and the movable contact 13a does not come into contact with any of the fixed contacts 7qc, 7qr, 7ql, 7qu, 7qd, and the fixed contacts 7qc and 7qu are opened, and the state is switched from the ON state to the OFF state.

[0037] If the operation knob 4 is rocked rearward B in FIG. 2 from the state shown in FIG. 6B the operation shaft 3 is rocked, the plunger 8 is moved along the oblique surface 2f (FIG. 7A and the like) of the guide pedestal 2a in the direction F opposite from the operating direction B, and the slider 9 is moved to the opposite direction F in parallel to the substrate 7. Therefore, the movable contacts 13a come into contact with the fixed contact 7qd and 7qc, respectively, and the fixed contacts 7qd and 7qc are switched from the OFF state to the ON state. If the operation knob 4 is rocked leftward L in FIG. 2, the operation shaft 3 is rocked, the plunger 8 is moved along the oblique surface 2r (FIG. 9) of the guide pedestal 2a in the opposite direction R, and the slider 9 is moved in the opposite direction R in parallel to the substrate 7. Therefore, the movable contacts 13a come into contact with fixed contact 7ql, and the fixed contact 7ql is switched from the OFF state to the ON state. If the operation knob 4 is rocked rightward R, the operation shaft 3 is rocked, the

78491-36

plunger 8 is moved along the oblique surface 21 (FIG. 9) of the guide pedestal 2a in the opposite direction L, and the slider 9 is moved in the opposite direction L in parallel to the substrate 7. Therefore, the movable contacts 13a come
5 into contact with the fixed contact 7qr, and the fixed contact 7qr is switched from the OFF state to the ON state. These switching signals are output from the switching apparatus 100 to the control unit as signals for tilting the left side mirror downward, leftward or rightward, and the
10 control unit which received the signal drives the electric motor, and tilts the left side mirror downward, leftward or rightward through a predetermined angle.

[0038] On the other hand, if the operation knob 4 is rotated in the clockwise direction P in FIG. 2 from the
15 initial state, the operation shaft 3, the outer striker 5, the slider 9 and the like rotate in the clockwise direction P through 45°, the movable contact 13a moves to a position close to the fixed contacts 7pc, 7pr, 7pl, 7pu, 7pd, and it becomes possible to adjust the visual angle of the right
20 side mirror. If the operation knob 4 is rocked forward F, rearward B, leftward L or rightward R from this rotation state, the operation shaft 3 is rocked in the operation direction in the same manner as that described above, and the plunger 8, the slider 9 and the terminal 13 are moved in
25 the opposite direction. Therefore, the movable contact 13a comes into contact with the fixed contacts 7pc, 7pr, 7pl, 7pu, 7pd, and the fixed contacts are switched from the OFF state to the ON state. These switching signals are output from the switching apparatus 100 to the control unit as
30 signals for tilting the right side mirror upward, downward, leftward or rightward, and the control unit which received the signal drives the electric motor, and tilts the right

78491-36

side mirror upward, downward, leftward or rightward through a predetermined angle.

[0039] If the operation knob 4 is pushed to move the operation shaft 3 downward, the inner striker 6 follows the operation shaft 3 and moves downward to push the actuator 11a of the push switch 11. Therefore, the inner contact of the push switch 11 can be switched from the OFF state to the ON state. If the operation knob 4 is rotated to rotate the operation shaft 3, the slider 9 follows the operation shaft 3 and rotates, and a contact with which the movable contact 13a on the slider 9 can come into contact can be switch to the fixed contacts 7pc, 7pr, 7pl, 7pu, 7pd or the fixed contacts 7qc, 7qr, 7ql, 7qu, 7qd of the substrate 7. If the operation knob 4 is rocked to rock the operation shaft 3, the slider 9 follows the operation shaft 3 and moves in parallel to the substrate 7, and the movable contact 13a comes into contact with any of the fixed contacts 7pc, 7pr, 7pl, 7pu, 7pd, 7qc, 7qr, 7ql, 7qu, 7qd. Therefore, the contacted fixed contact can be switched from the OFF state to the ON state. Therefore, different switching actions can be realized by pushing, rotating and rocking the one operation knob 4, and it is possible to remarkably enhance the operability as compared with the conventional switching apparatus provided with a plurality of operation knobs which are operated in the different manners.

[0040] The inner contact of the push switch 11 and the fixed contacts 7pc, 7pr, 7pl, 7pu, 7pd, 7qc, 7qr, 7ql, 7qu, 7qd are provided on the same substrate 7. Therefore, the number of parts is smaller than the switching apparatuses as disclosed in Japanese Patent Application Laid-Open No. 2001-

78491-36

291456 and Japanese Patent No. 3033205 in which the plurality of contacts are separated into the plurality of members, and the structure can be simplified. Further, the switching apparatus 100 can be reduced in size in the height
5 direction (vertical direction U, D).

[0041] The substrate 7 is provided at its upper surface with the push switch 11, and is provided at its opposite lower surface with the fixed contacts 7pc, 7pr, 7pl, 7pu, 7pd, 7qc, 7qr, 7ql, 7qu, 7qd. Therefore, it is easy to
10 dispose the push switch 11 and the fixed contacts 7pc, 7pr, 7pl, 7pu, 7pd, 7qc, 7qr, 7ql, 7qu, 7qd on the substrate 7 as compared with the switching apparatuses disclosed in Japanese Patent Application Laid-Open No. 2001-291456 and Japanese Patent No.3033205 in which all of the contacts are
15 provided on the upper surface of the substrate. The substrate 7 can be reduced in size, and the switching apparatus 100 can be reduced in size in its width direction (forward F, backward B, leftward L and rightward R). In addition, the upper surface of the substrate 7 may be
20 provided with the space in which a part (inner striker 6) for switching the inner contact of the push switch 11 moves upward, and the lower surface of the substrate 7 may be provided with the space in which parts (slider 9 and terminal 13) for switching the fixed contacts 7pc, 7pr, 7pl,
25 7pu, 7pd, 7qc, 7qr, 7ql, 7qu, 7qd are switched move in the width direction. Therefore, it becomes easy to secure each moving space as compared with the switching apparatus disclosed in Japanese Patent No. 3033205 in which the upper surface of the substrate is provided with the moving space
30 for all of parts for switching the contacts, and it is possible to reduce the switching apparatus 100 in the height direction and width direction.

78491-36

[0042] The inner contact of the push switch 11 is employed as a contact which is switched by pushing the operation knob 4, and the push switch 11 is mounted on the upper surface of the substrate 7. Therefore, it is easier to dispose the contact and the number of parts required for switching the contact is smaller (two, i.e., the operation shaft 3 and the inner striker 6), and the structure of the switching apparatus 100 can further be simplified as compared with the switching apparatus as disclosed in Japanese Patent Application Laid-Open No.2001-291456 in which the fixed contact and the movable contact are provided separately as contacts which are switched by pushing the operation knob.

[0043] The fixed contacts 7pc, 7pr, 7pl, 7pu, 7pd, 7qc, 7qr, 7ql, 7qu, 7qd can be switched by the same movable contact 13a. Therefore, as compared with the switching apparatuses disclosed in Japanese Patent Application Laid-Open No. 2005-44582 and Japanese Patent Application Laid-Open No. 2004-134239 in which the contact which is switched by rotating the operation knob 4 and the contact which is switched by rocking are switched by different movable contacts, it is possible to reduce the number of parts required for switching the fixed contacts 7pc, 7pr, 7pl, 7pu, 7pd, 7qc, 7qr, 7ql, 7qu, 7qd (three, i.e., the operation shaft 3, the slider 9 and the terminal 13), and the structure of the switching apparatus 100 can further be simplified. Since the fixed contacts 7pc, 7pr, 7pl, 7pu, 7pd, 7qc, 7qr, 7ql, 7qu, 7qd and the movable contact 13a are provided on the same surface of the substrate 7. Therefore, it is possible to further simplify the switching structure of the fixed contacts 7pc, 7pr, 7pl, 7pu, 7pd, 7qc, 7qr, 7ql, 7qu, 7qd as compared with the switching apparatuses

78491-36

disclosed in Japanese Patent Application Laid-Open No. 2005-44582 to Japanese Patent Application Laid-Open No. 2001-291456 in which the movable contact is provided on the lower surface of the substrate 7 and the fixed contact is provided
5 on the upper surface of the substrate 7.

[0044] Further, since the push switch 11 is provided, the click feeling can be exhibited when the operation knob 4 is pushed, and since the outer striker 5 and the guide wall 1c are provide, the click feeling can be exhibited when the
10 operation knob 4 is rotated. Since the plunger 8, the coil spring 10 and the guide pedestal 2a are provided, the click feeling can be exhibited when the operation knob 4 is rocked. Therefore, the operation knob 4 can appropriately be pushed, rotated and rocked while relying on the click
15 feeling, and the inner contact of the push switch 11 and the fixed contacts 7pc, 7pr, 7pl, 7pu, 7pd, 7qc, 7qr, 7ql, 7qu, 7qd of the substrate 7 can normally be switched, and the operability can further be enhanced. In addition, because the number of parts which exhibit the click feeling is
20 reduced, the structure of the switching apparatus 100 can be simplified.

[0045] According to the above-described embodiment, the present invention is applied to the switching apparatus 100 used for the power mirror apparatus of the automobile, but
25 the invention can also be applied to a switching apparatus used for a purpose other than the power mirror apparatus that can be operated by pushing, rotating and rocking.

78491-36

CLAIMS:

1. A switching apparatus comprising
- a case,
- an operation shaft whose one end outwardly
- 5 projects from inside of the case and which is provided at its central portion with a flange,
- a support member which supports the flange such that the operation shaft can rock and rotate,
- an operation knob mounted on one end of the
- 10 operation shaft,
- a first contact which is switched when the operation knob is pushed to move the operation shaft and the support member is moved,
- a second contact which is switched when the
- 15 operation knob is rotated to rotate the operation shaft,
- a third contact which is switched when the operation knob is rocked to rock the operation shaft, and
- a substrate respectively having the first, second and third contacts.
- 20 2. A switching apparatus according to claim 1, wherein the substrate is provided at its one of surfaces with the first contact, and at its other surface with the second and third contacts.
3. A switching apparatus according to claim 1 or 2,
- 25 wherein the first contact is provided in a push switch having an actuator which is mounted on the surface of the

78491-36

substrate on the side of the operation knob and which can be pushed, the actuator is switched if the actuator is pushed by the support member.

4. A switching apparatus according to any one of
5 claims 1 to 3, further comprising a movable contact which can follow the operation shaft and rotate and which can move in parallel to the substrate in a state in which the movable contact is in contact with the substrate on the substrate on the opposite side from the operation knob, wherein

10 the second and third contacts are fixed contacts formed on the surface of the substrate opposite from the operation knob,

when the operation shaft is rotated, the movable contact rotates to switch the second contact, and when the
15 operation shaft is rocked, the movable contact moves in parallel to the substrate to switch the third contact.

SMART & BIGGAR

OTTAWA, CANADA

PATENT AGENTS

1/13

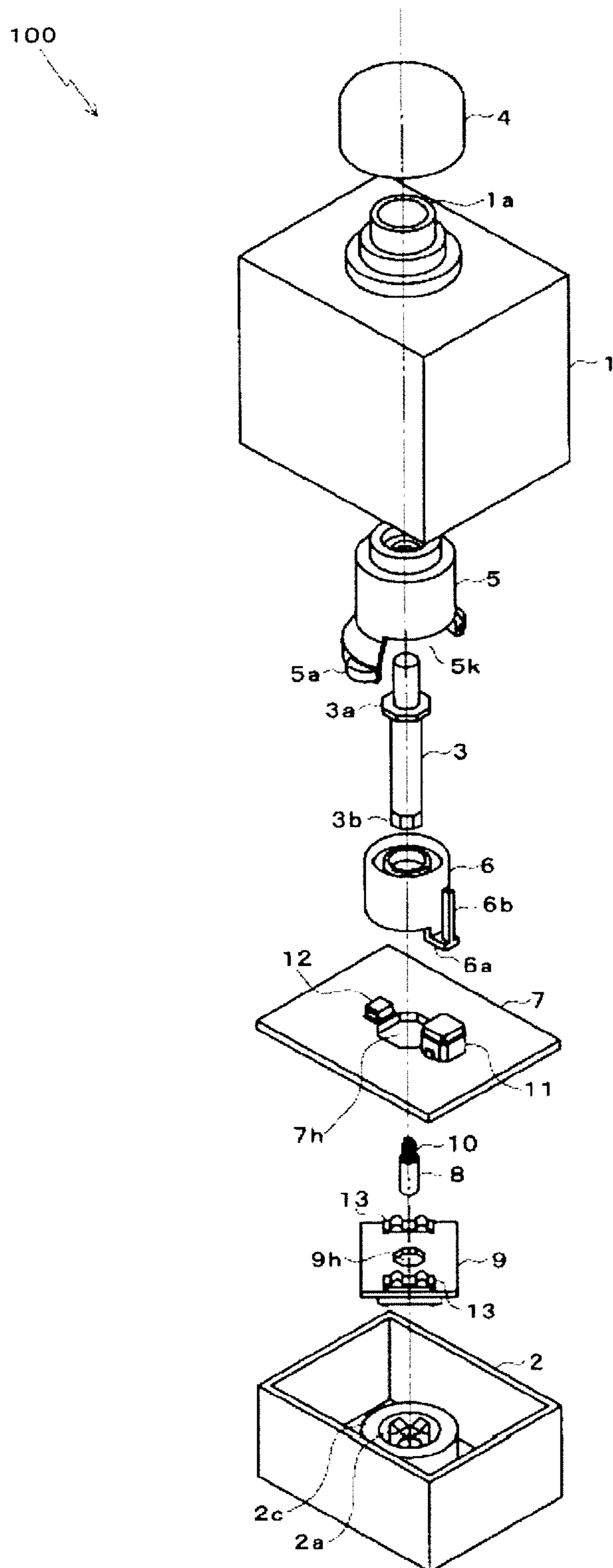

FIG. 1

FIG. 2A

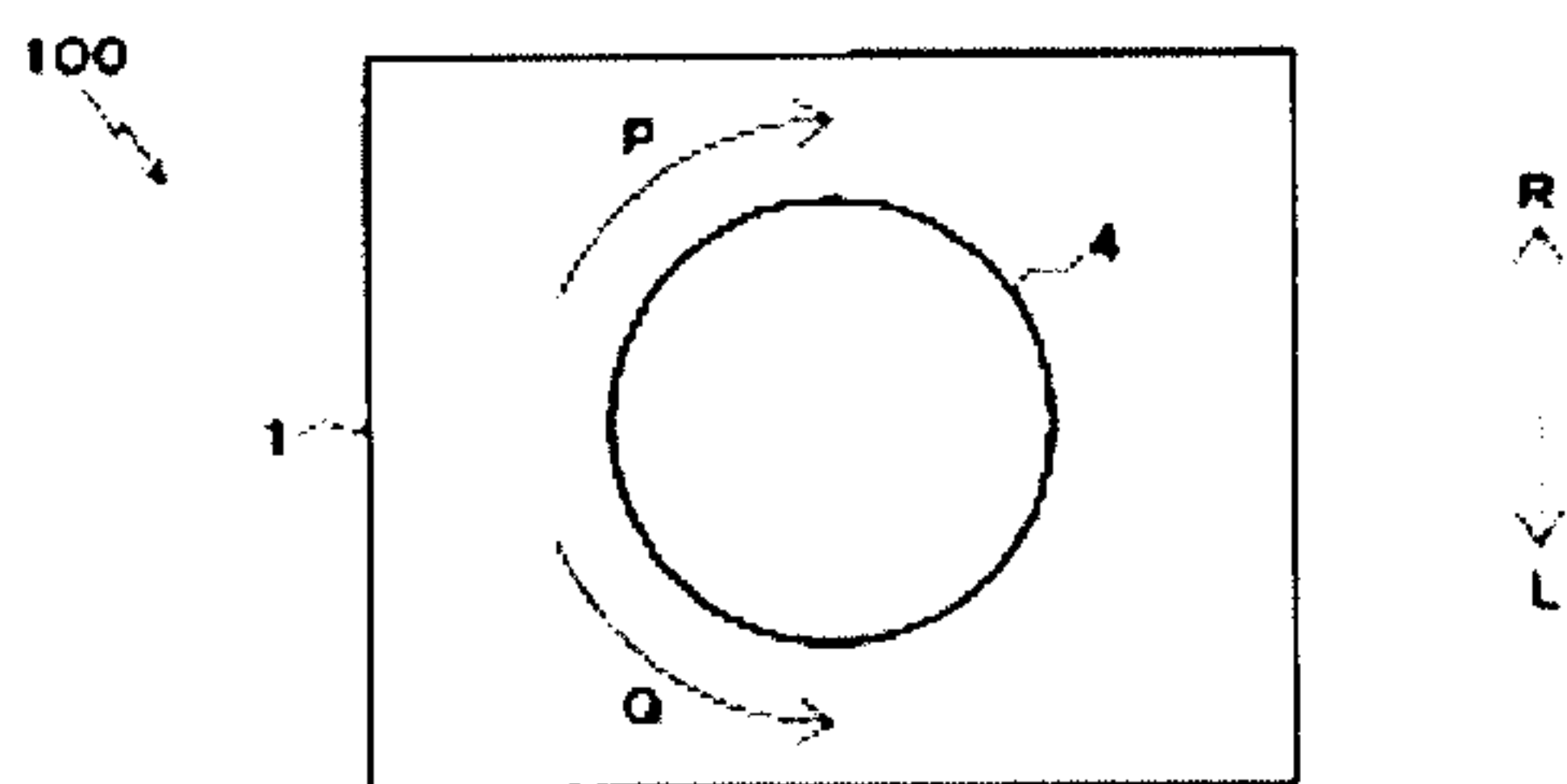

FIG. 2B

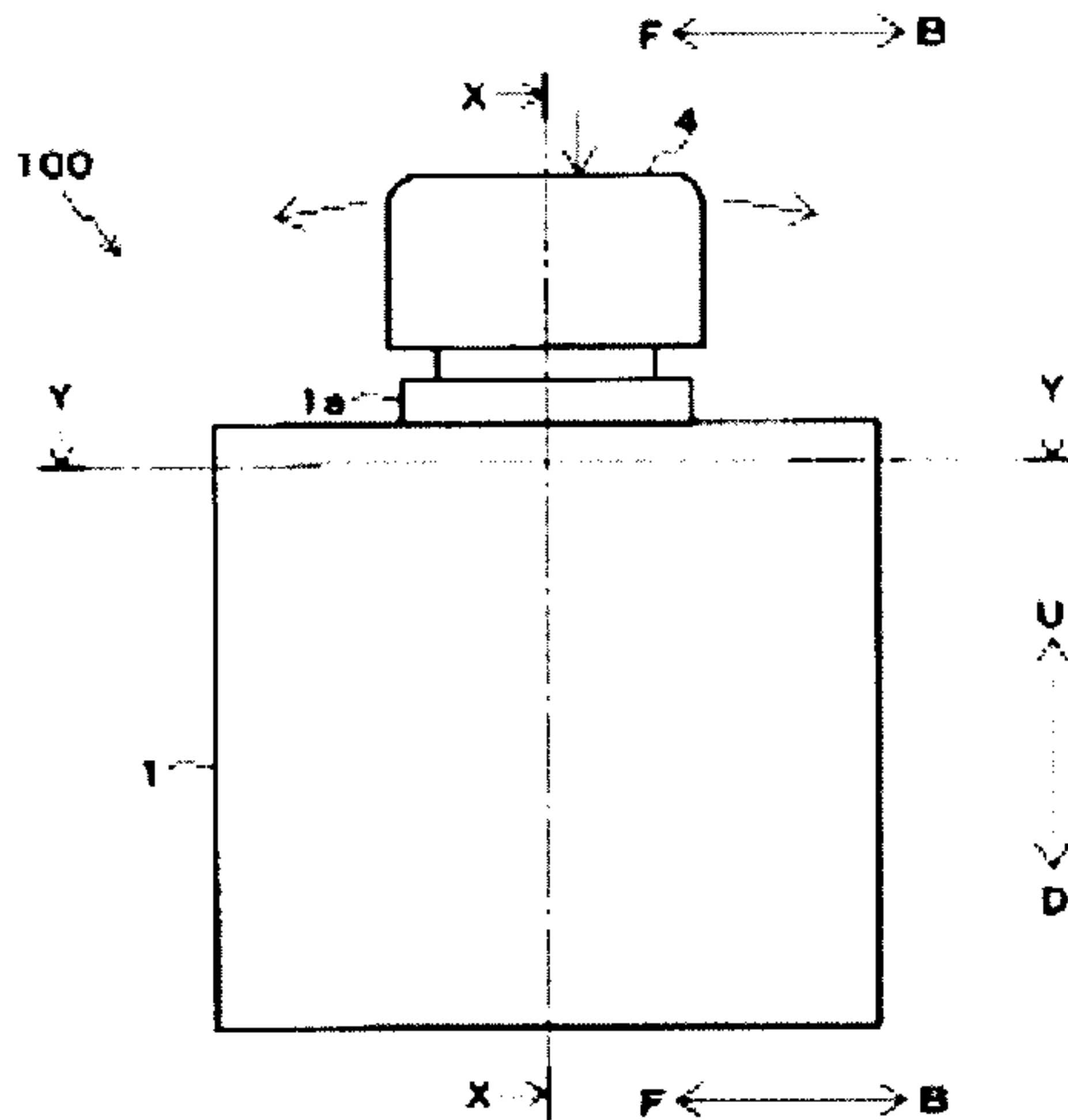
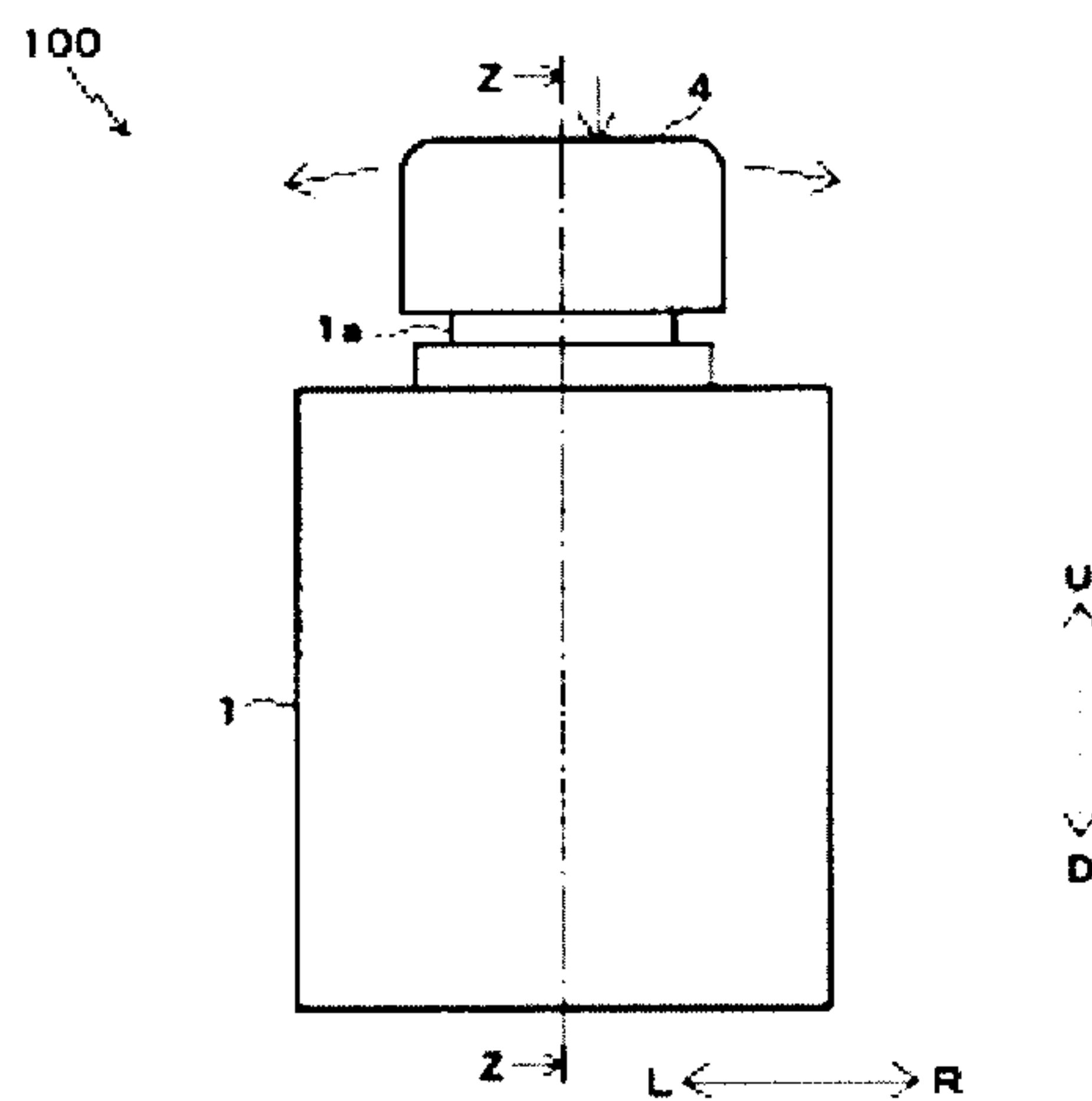

FIG. 2C



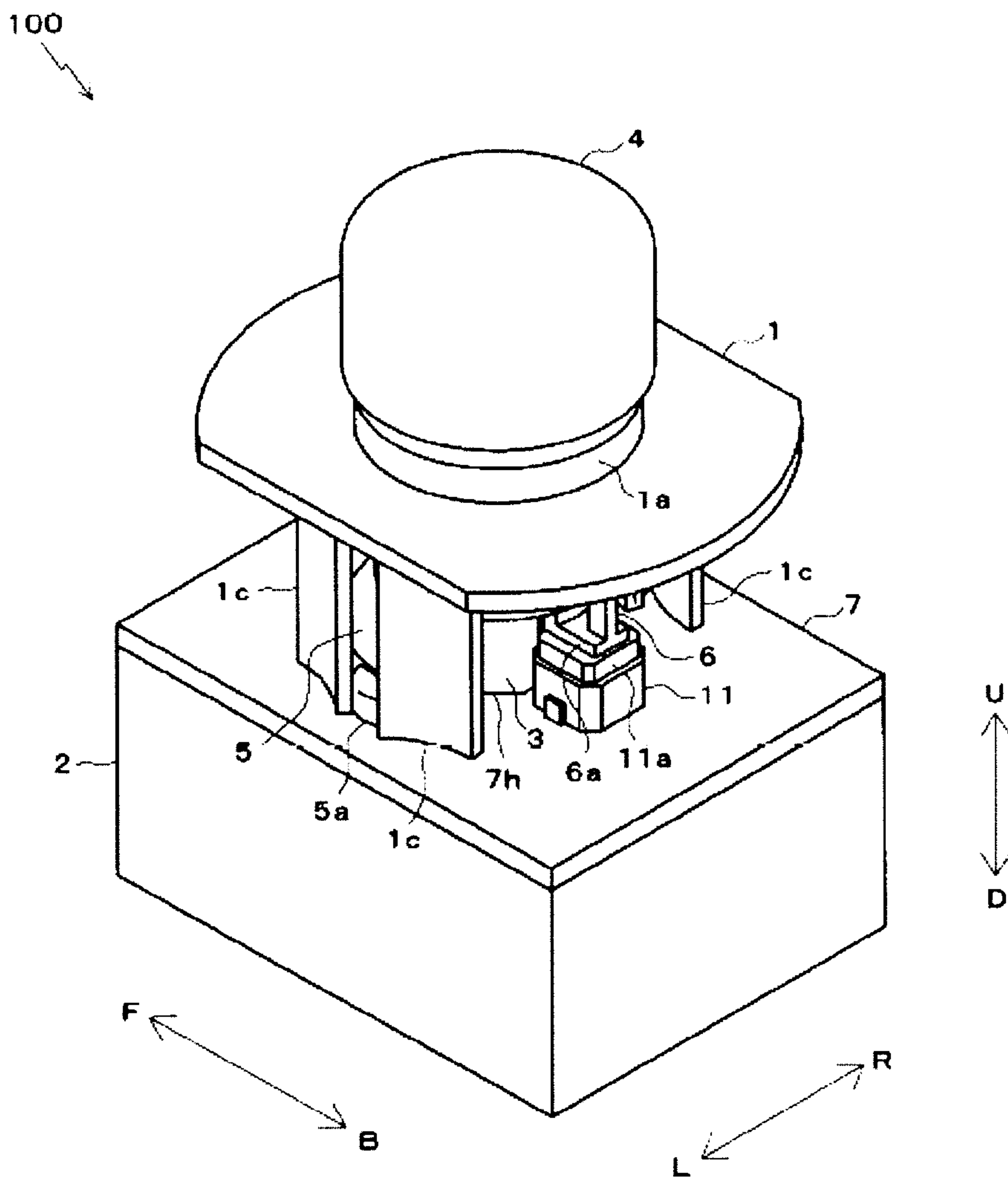

FIG. 3

FIG. 4A

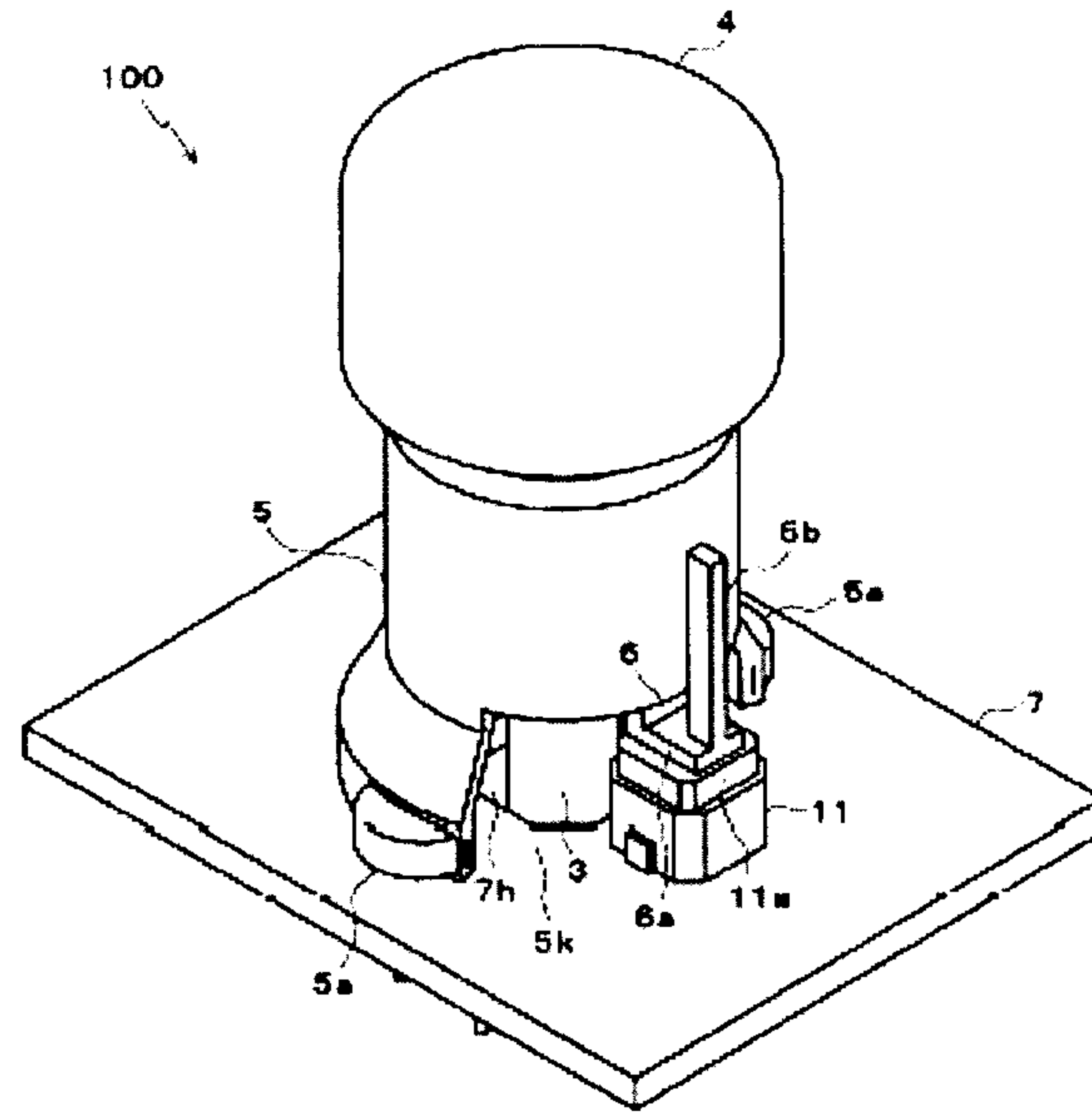
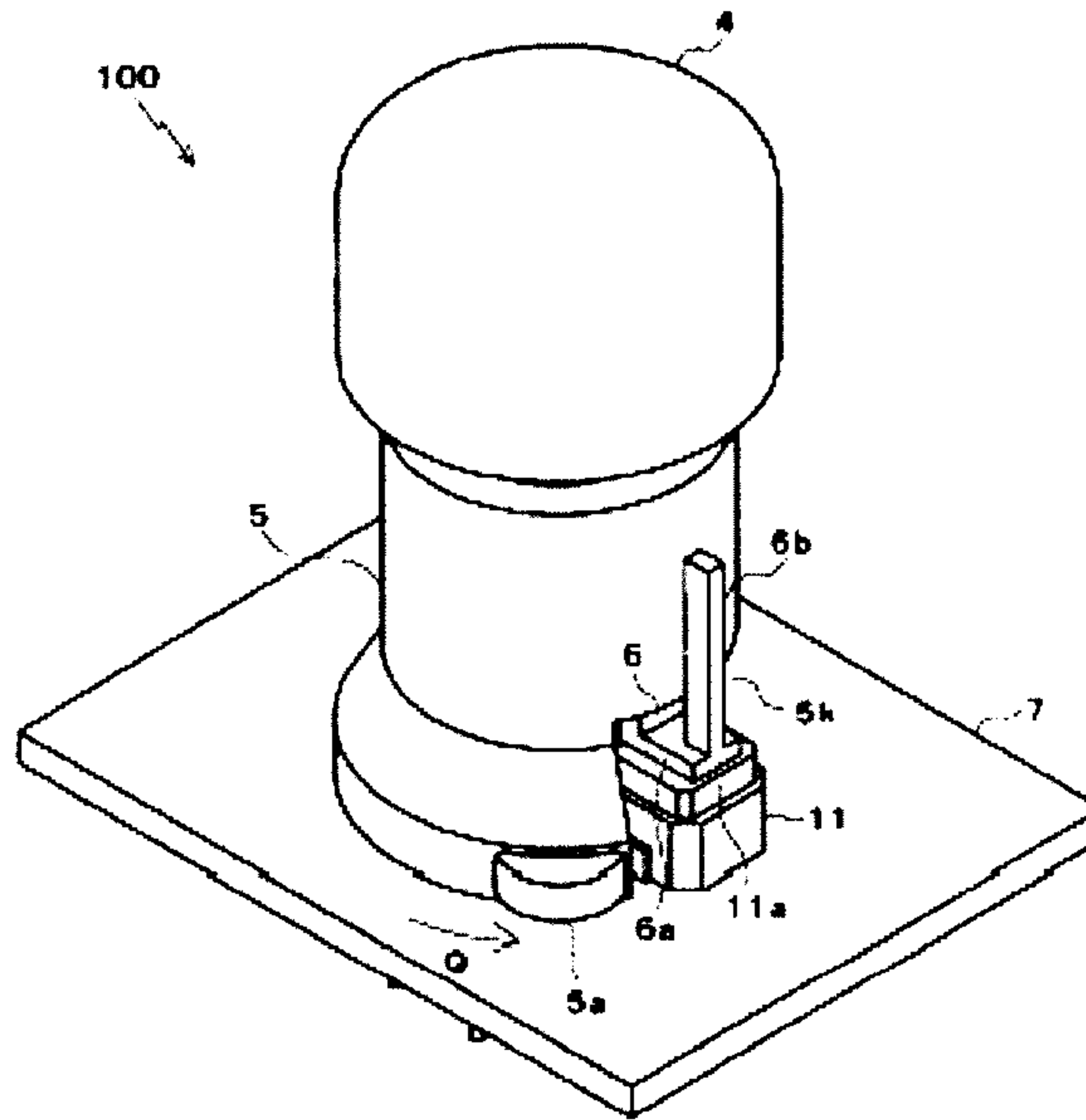

FIG. 4B



5/13

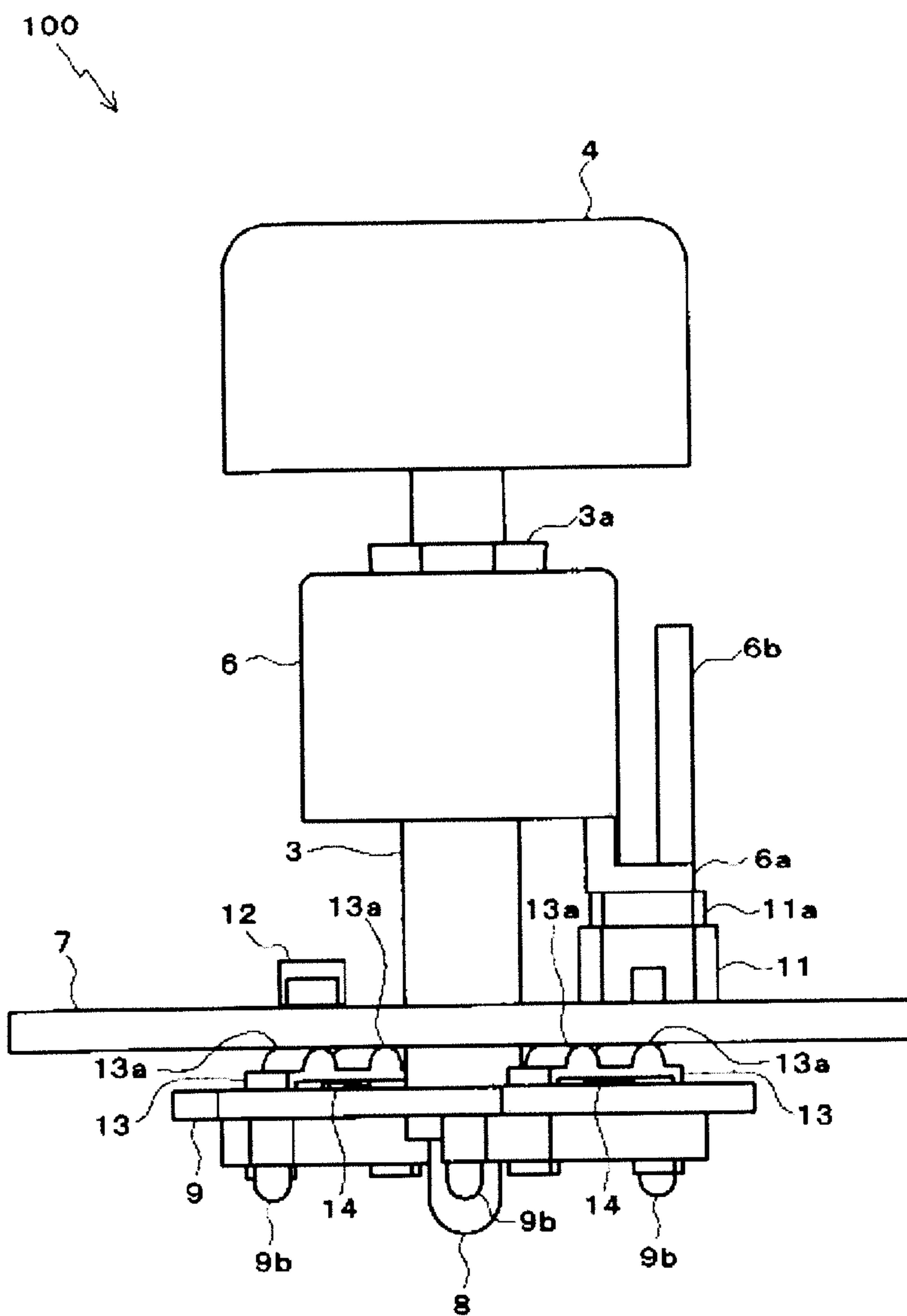

FIG. 5

FIG. 6A

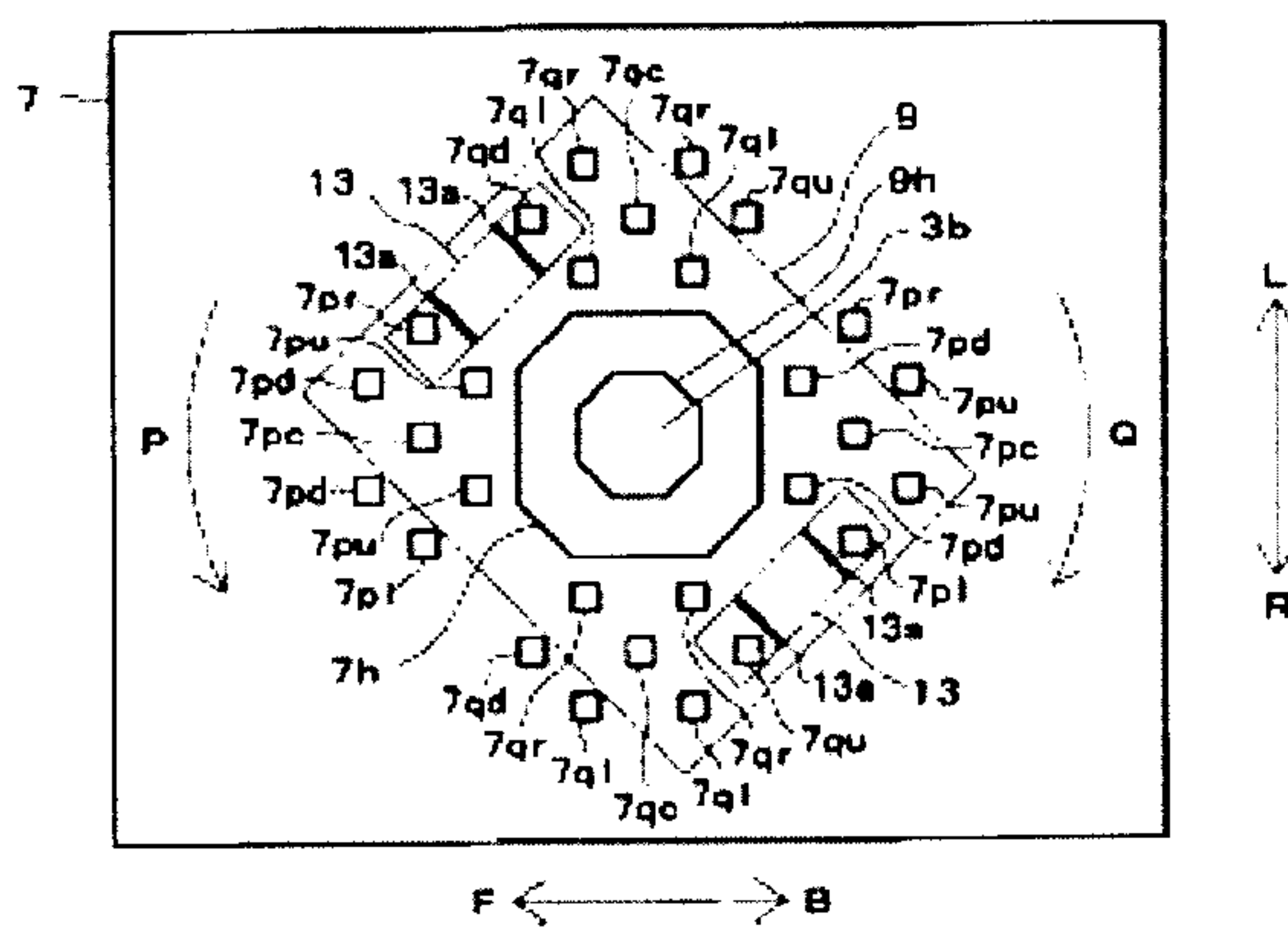

FIG. 6B

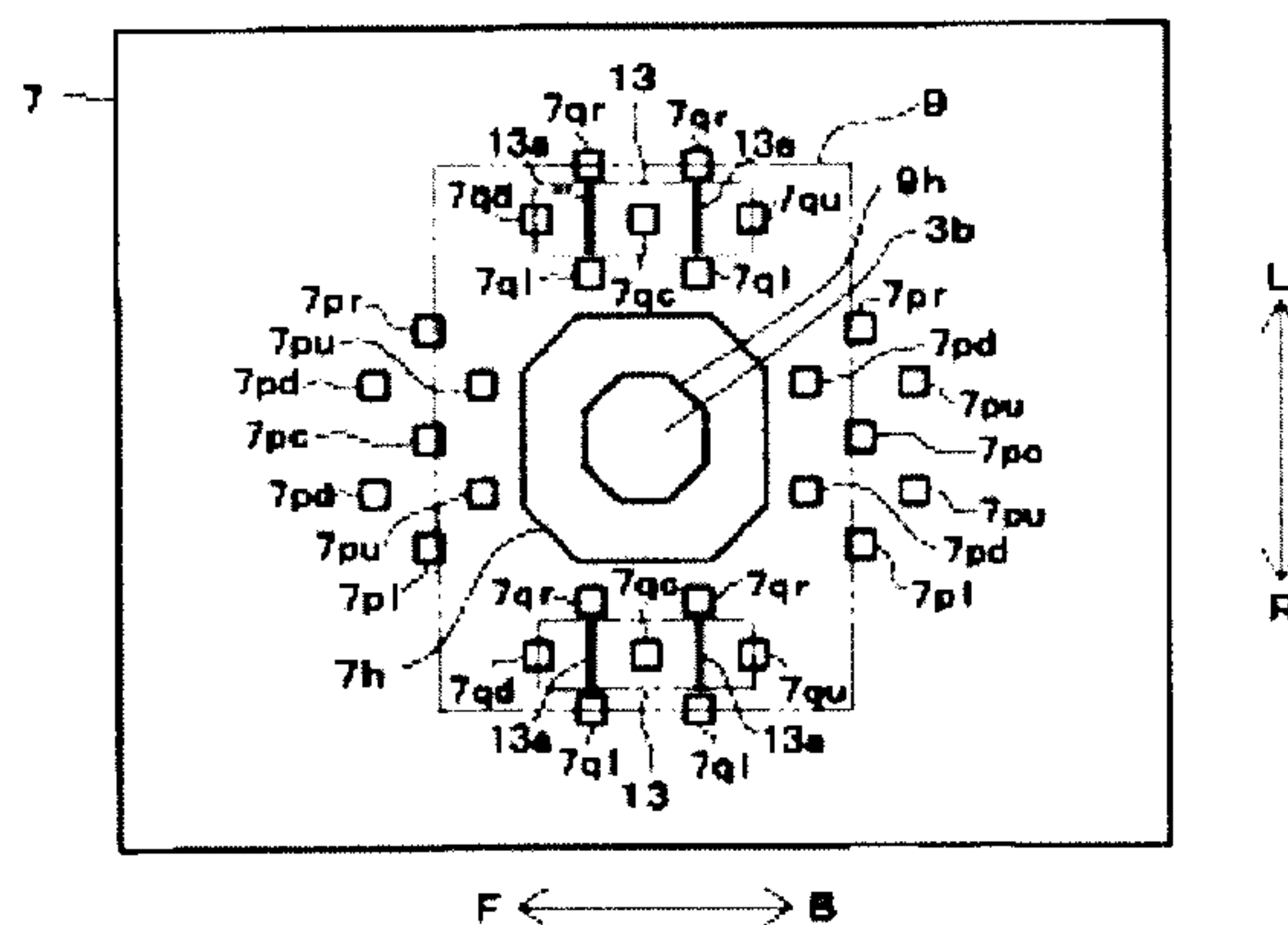
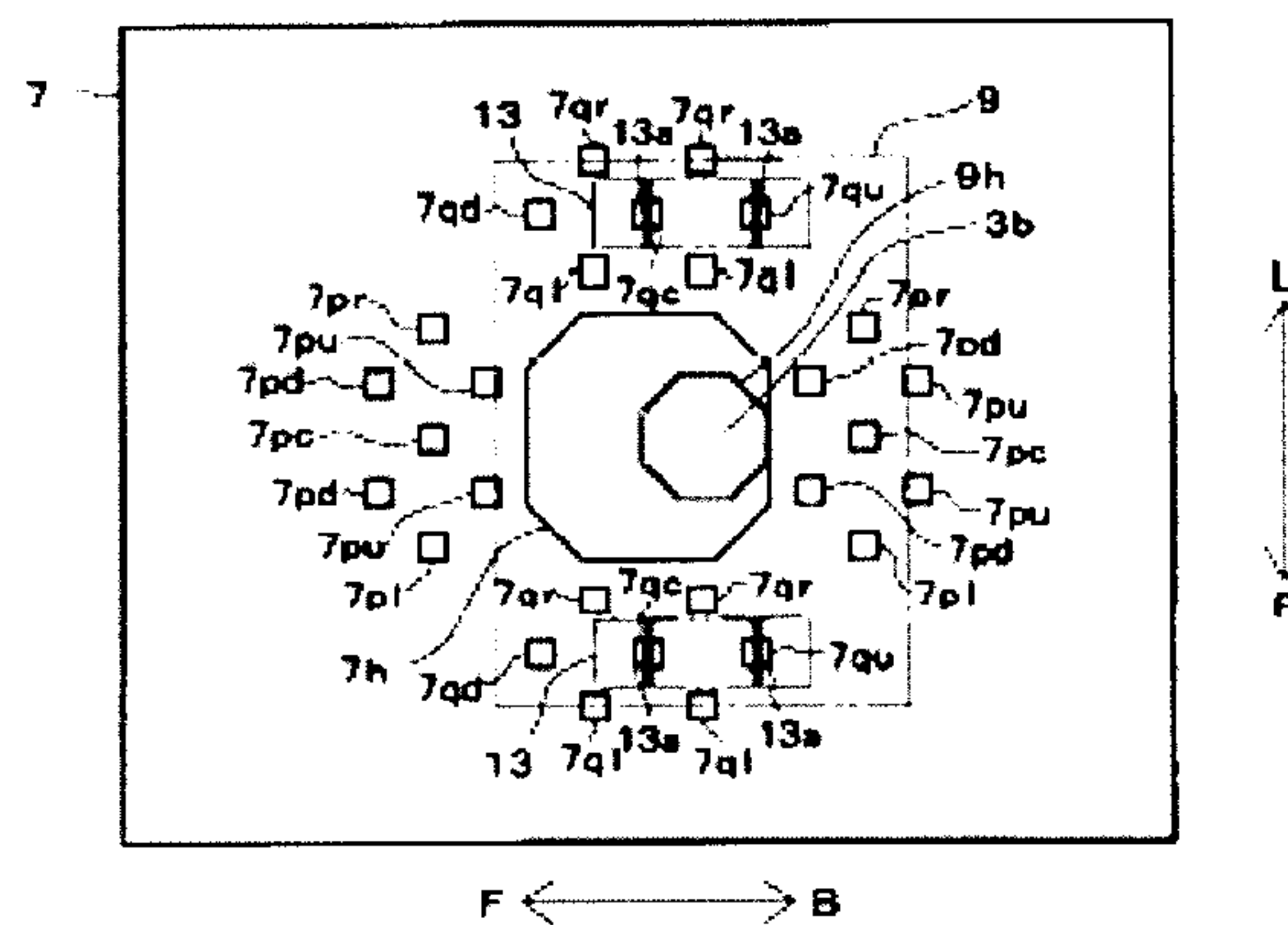

FIG. 6C



7/13

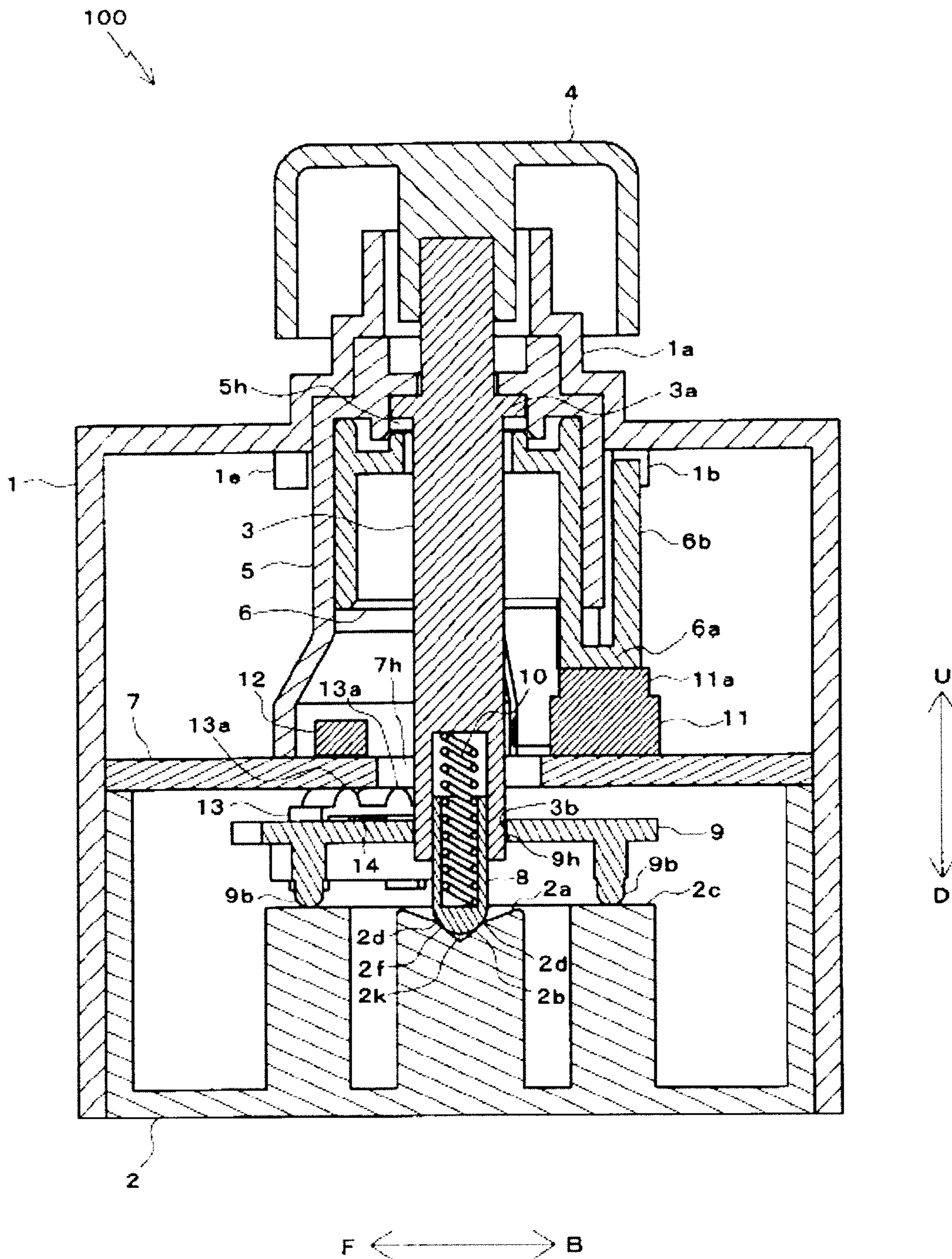

FIG. 7A

8/13

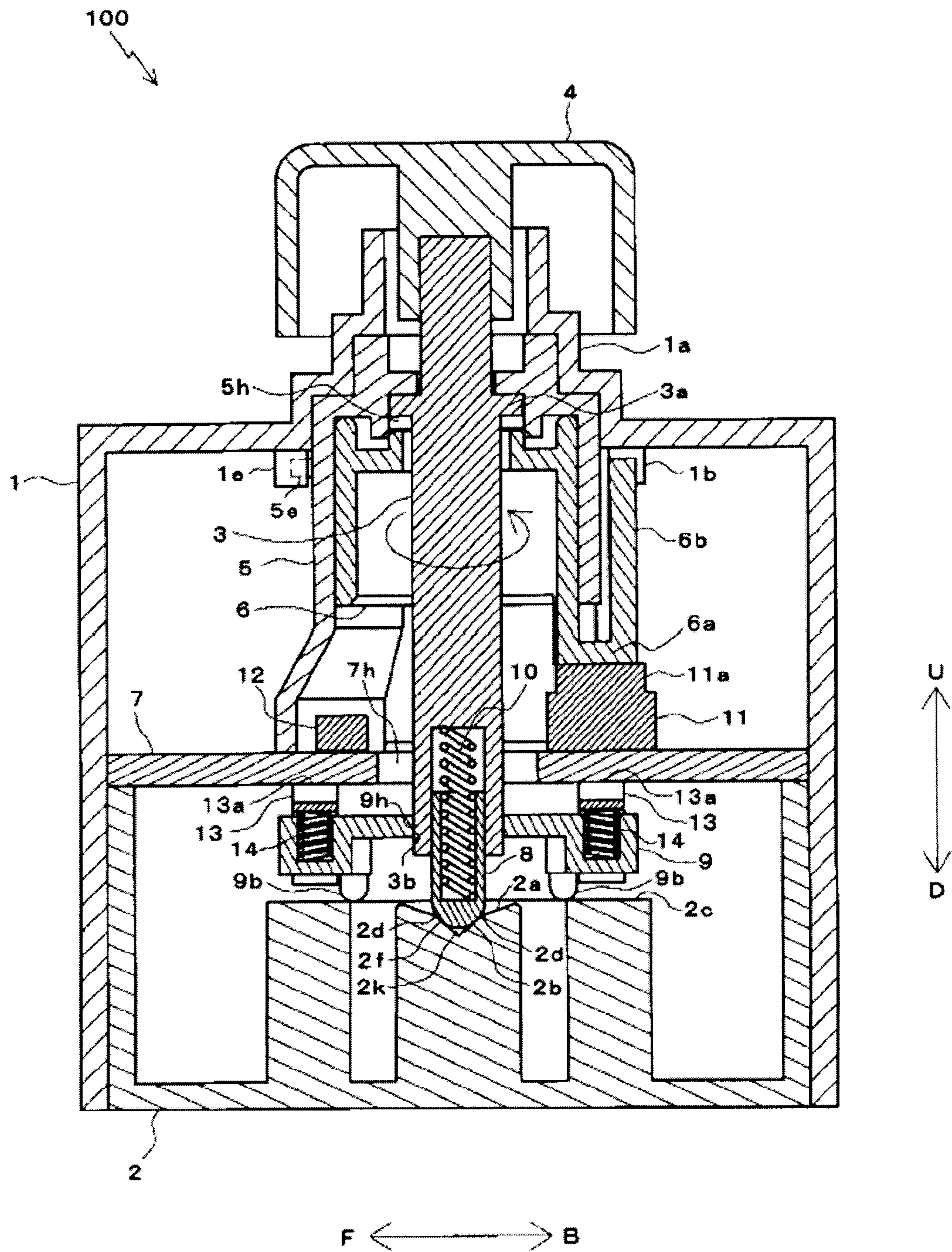
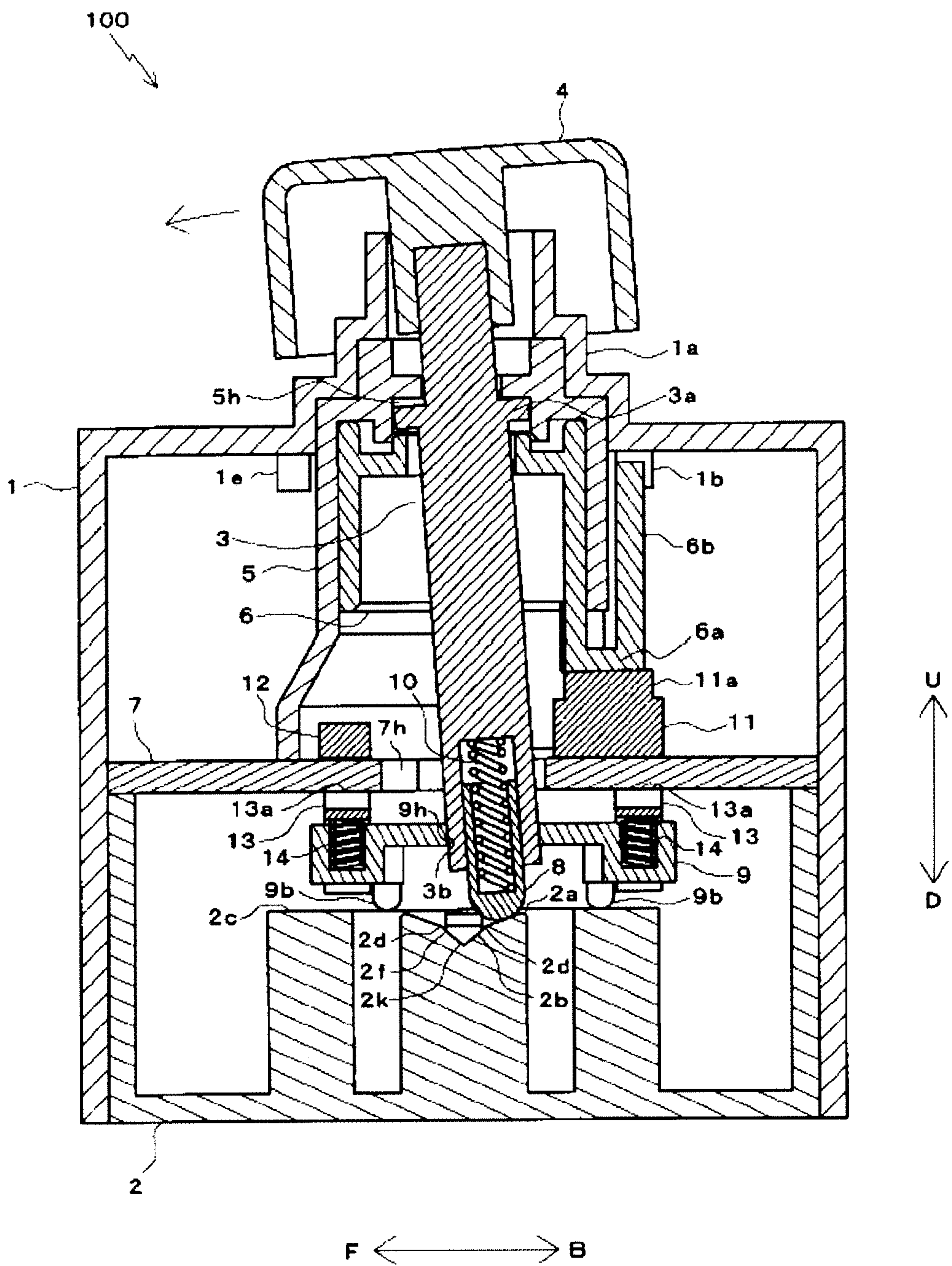

FIG. 7B

9/13



10/13

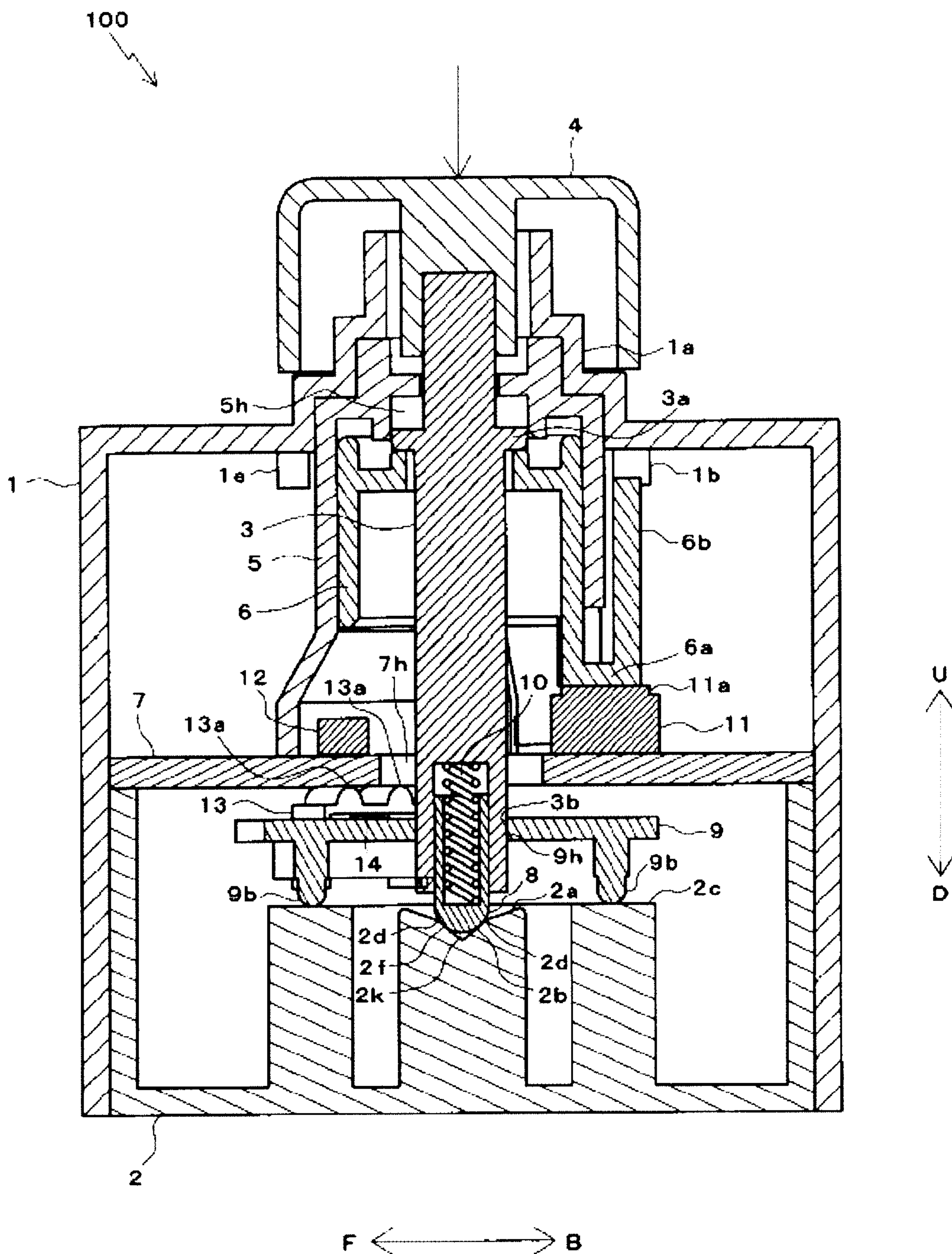

FIG. 7D

FIG. 8A

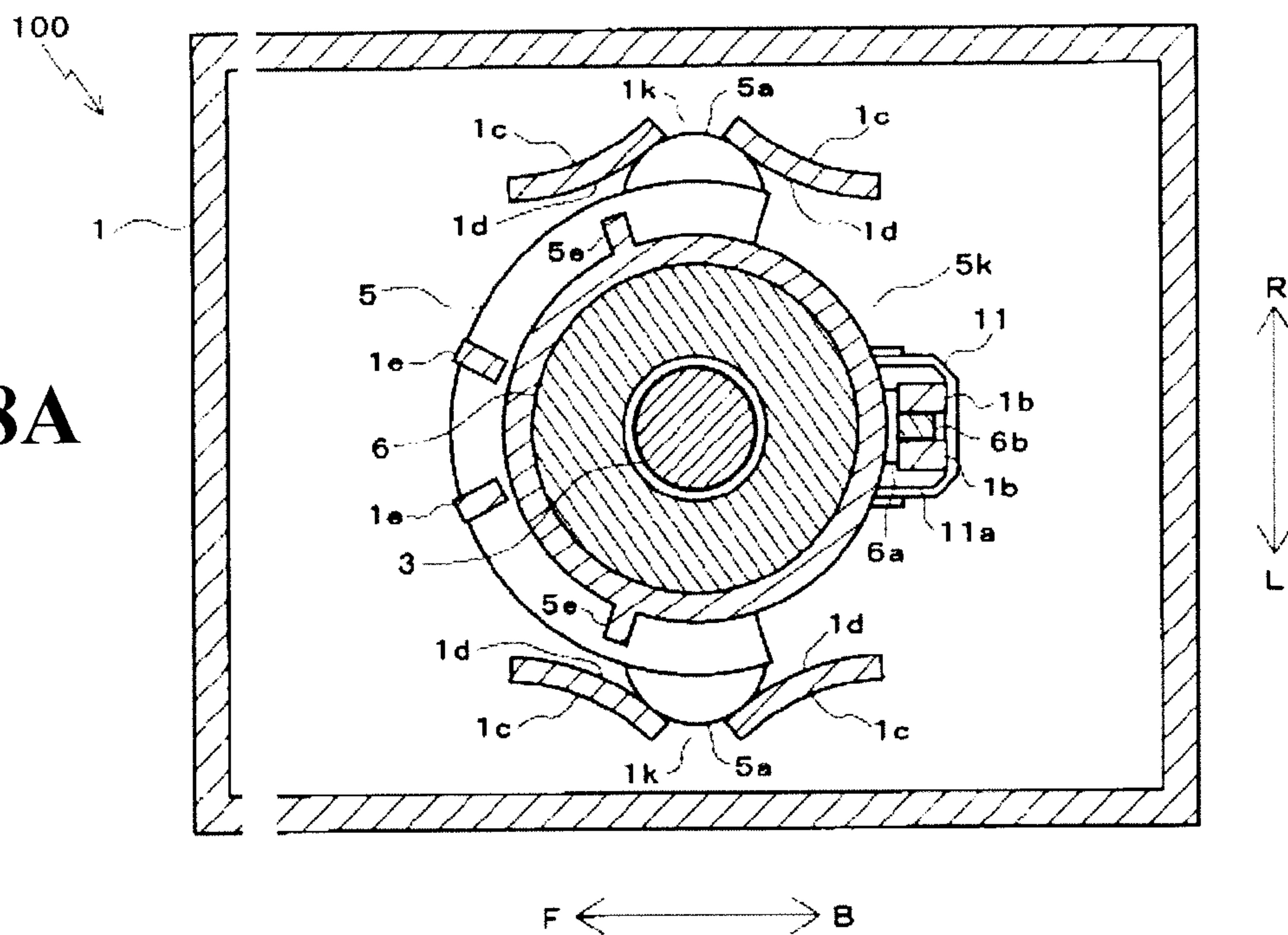
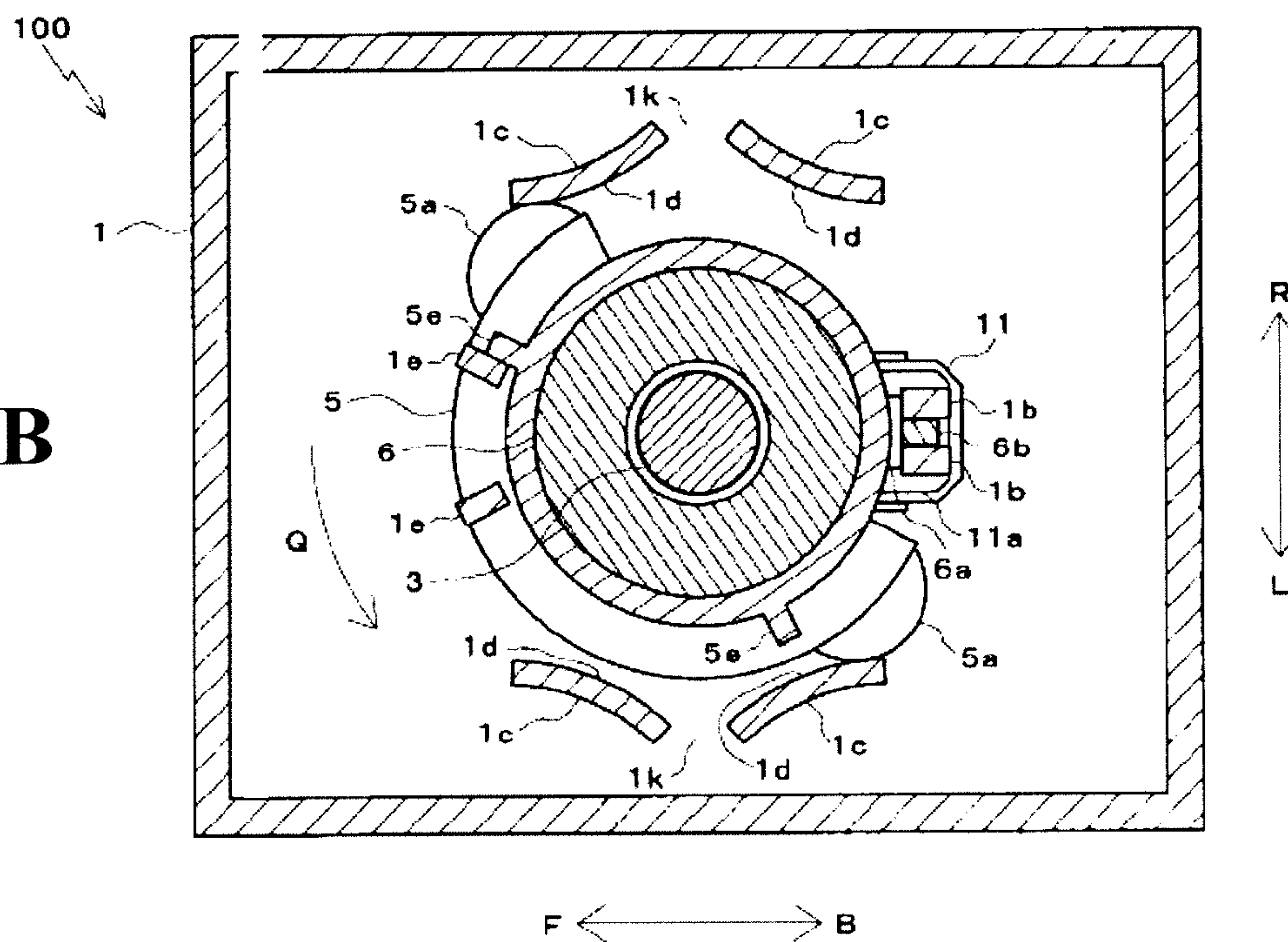

FIG. 8B



12/13

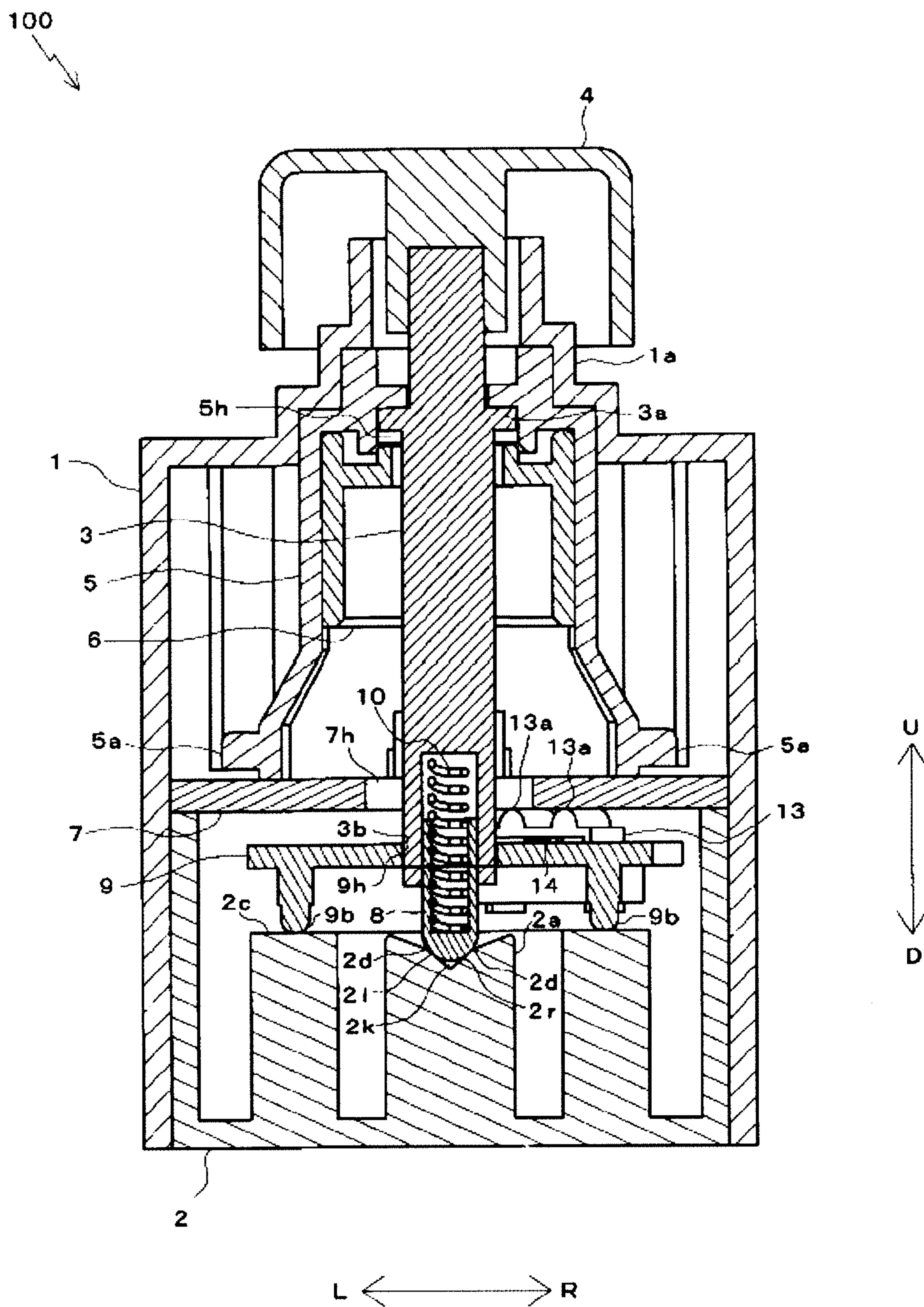

FIG. 9

13/13

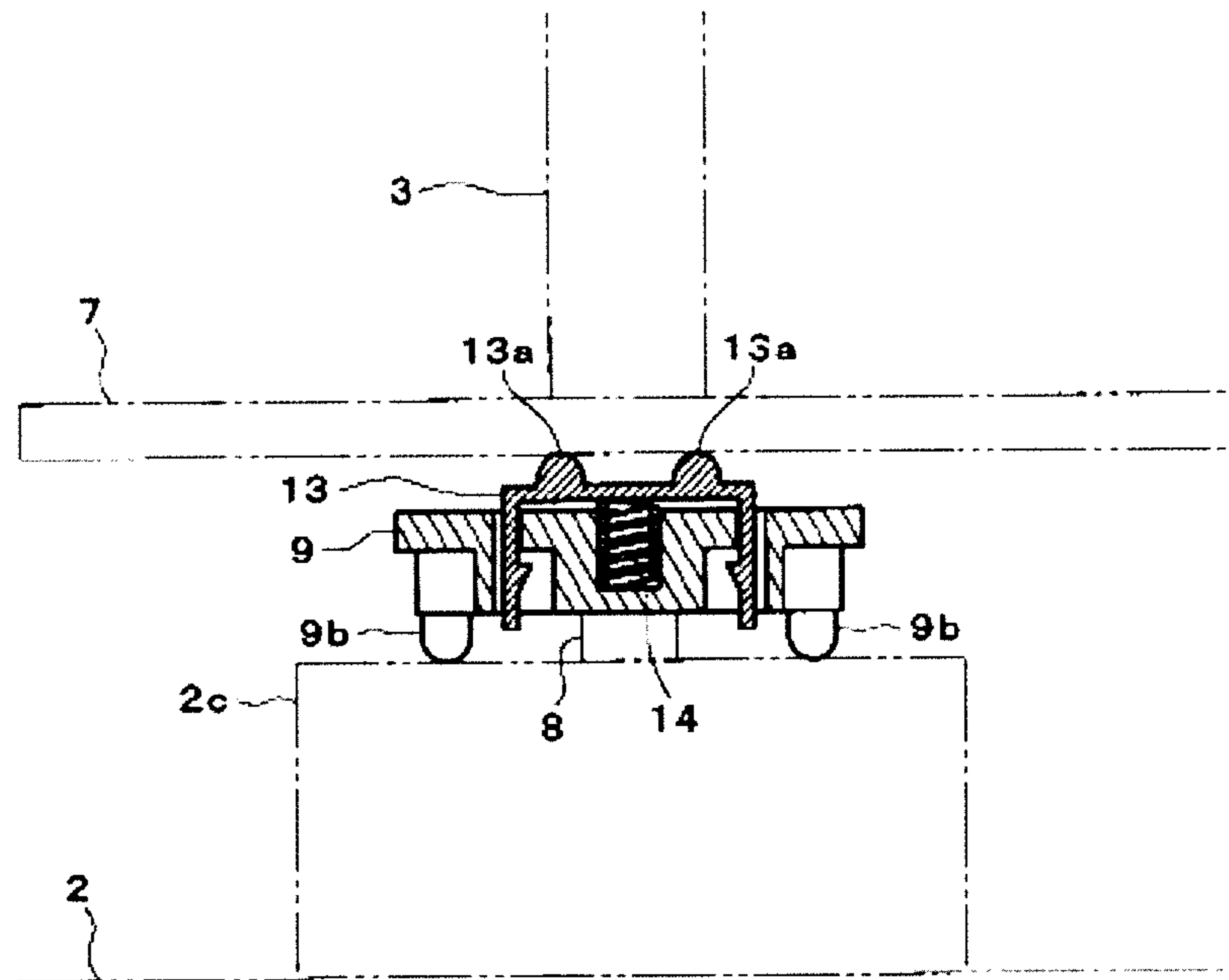
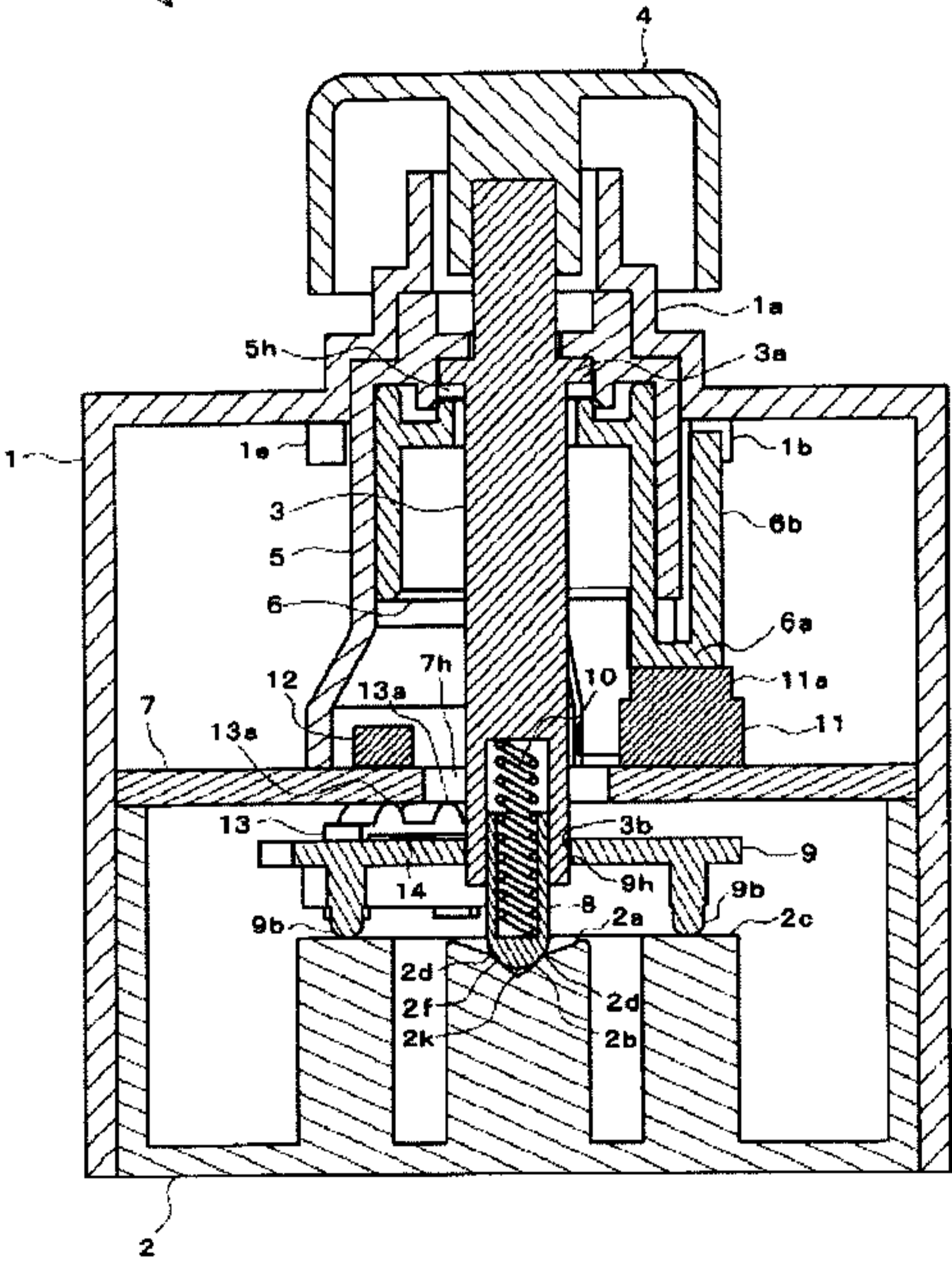

FIG. 10

100



F ← → B

U
↑
↓
D