

(19)



(11)

**EP 2 189 578 B1**

(12)

**EUROPEAN PATENT SPECIFICATION**

(45) Date of publication and mention of the grant of the patent:  
**24.07.2013 Bulletin 2013/30**

(51) Int Cl.:  
**E02F 3/815 (2006.01) E02F 3/96 (2006.01)**

(21) Application number: **09176786.3**

(22) Date of filing: **23.11.2009**

**(54) Accessory pushing implement for a convertible earthmoving machine**

Zusatzplaniergerüst für konvertierbare Baumaschine

Appareil de nivellement accessoire pour machine de construction convertible

(84) Designated Contracting States:  
**AT BE BG CH CY CZ DE DK EE ES FI FR GB GR HR HU IE IS IT LI LT LU LV MC MK MT NL NO PL PT RO SE SI SK SM TR**

- **Caporale, Davide**  
**10072 Mappano di Caselle (IT)**
- **Fontana, Luca**  
**10129 Torino (TO) (IT)**

(30) Priority: **21.11.2008 IT TO20080861**

(74) Representative: **Gunst, Wilfried E.D.**  
**CNH IP Department,**  
**CNH Belgium N.V.,**  
**Patent Department,**  
**Leon Claeysstraat 3A**  
**8210 Zedelgem (BE)**

(43) Date of publication of application:  
**26.05.2010 Bulletin 2010/21**

(73) Proprietor: **New Holland Kobelco Construction Machinery S.p.A.**  
**10099 San Mauro Torinese (TO) (IT)**

(56) References cited:  
**WO-A1-94/11584 GB-A- 1 265 110**  
**JP-A- 2001 081 808 JP-U- 4 017 446**  
**JP-U- 48 063 902 US-A- 3 386 519**  
**US-A- 3 628 612 US-A1- 2001 045 031**

(72) Inventors:  
 • **Lombardo, Orlando**  
**10078 Venaria (TO) (IT)**

**EP 2 189 578 B1**

Note: Within nine months of the publication of the mention of the grant of the European patent in the European Patent Bulletin, any person may give notice to the European Patent Office of opposition to that patent, in accordance with the Implementing Regulations. Notice of opposition shall not be deemed to have been filed until the opposition fee has been paid. (Art. 99(1) European Patent Convention).

## Description

**[0001]** The present invention relates to an earthmoving machine.

**[0002]** Earthmoving machines are divided into various categories, one of which includes bulldozers, i.e. pushing and/or levelling machines with a liftable blade across the front, and another of which includes boom-operated machines commonly known as excavators. Excavators comprise an articulated boom fitted on the end with a bucket and controlled by a dedicated hydraulic circuit. The bucket may be replaced with accessory implements, such as wrecking and grabbing devices; in which case, an independent auxiliary hydraulic valve is fitted to a portion of the boom close to the bucket, and is connected hydraulically to the excavator hydraulic control system.

**[0003]** The machines in each category being designed to perform a specific function, acquiring two different types of machine involves a considerable outlay in terms of both purchase and maintenance cost.

**[0004]** The current trend is therefore increasingly towards convertible machines, i.e. a machine of one category that can be converted to also perform the function of another. That is, one machine convertible to operate as both a bulldozer and excavator.

**[0005]** British Patent Application GB 2 341 167 describes a convertible earthmoving machine in which a horizontal push blade is connected integrally to an accessory structure hinged to the base of the machine, between the two tracks, to oscillate solely about a horizontal axis. The blade is lifted and lowered by the machine's articulated boom, and the bucket teeth are inserted inside respective retaining pockets on the accessory structure. Machines of this sort, however, operate poorly, on account of the design of the blade/accessory structure assembly failing to withstand the same degree of stress as a corresponding bulldozer assembly. In other words, the machine represents a trade-off that falls short of users' expectations in terms of push performance. Moreover, the use of the machine is seriously limited by failure to adjust the position of the blade about a substantially longitudinal axis or substantially vertical axis.

**[0006]** The document JP-U-4017446 discloses a convertible earthmoving machine whereby an accessory connecting structure is hinged to the bottom frame of the vehicle. This structure, comprising connecting means for connection with the implement of a boom, may be raised or lowered under the control of an articulated boom.

**[0007]** It is an object of the present invention to provide a convertible earthmoving machine which, when converted, is capable of performing all the functions of the relative special-purpose machine, and which at the same time is cheap to produce, and highly efficient and reliable.

**[0008]** According to the present invention, there is provided an accessory implement for a convertible earthmoving machine according to claim 1. It is also an object of the present invention to provide a convertible earthmoving machine comprising an accessory implement.

**[0009]** A non-limiting embodiment of the invention will be described by way of example with reference to the accompanying drawings, in which:

5 Figure 1 shows a partial side view of a convertible earthmoving machine in accordance with the teachings of the present invention;

Figure 2 shows a schematic plan view, with parts removed for clarity, of the Figure 1 machine with a component part in different operating positions;

10 Figure 3 shows a partial view in perspective of an implement of the Figure 1 and 2 machine;

Figure 4 shows a larger-scale view of a further detail of Figure 1;

15 Figure 5 shows a front view of the Figure 2 component in three different operating positions;

Figure 6 shows a section of a Figure 3 detail.

**[0010]** Number 1 in Figure 1 indicates as a whole a convertible earthmoving machine. Machine 1 comprises a self-propelled bottom frame - in this case, fitted with tracks 3 and having a longitudinal axis 4; and a top frame 5 connected to bottom frame 2 on a swivel 6 (Figures 1 and 2) to rotate about a vertical hinge axis 7 perpendicular to longitudinal axis 4.

**[0011]** Top frame 5 supports an operator cab 8 and is fitted with a known articulated boom 9, not described in detail, fitted on its free end with an implement - in this case, a bucket 10. Boom 9 and bucket 10 are operated by hydraulic actuators 11 connected to a known main hydraulic circuit, whereas accessory implements connectable to boom 9, such as wrecking and grabbing devices, are powered by an auxiliary hydraulic circuit 13 terminating, close to the free end of boom 9, with a hydraulic connecting valve 13a connected in known manner to boom 9.

**[0012]** With reference to Figure 1, the machine also comprises an accessory pushing implement 14 located to the front of bottom frame 2 and in turn comprising a transverse front push blade 15 connected to bucket 10 on one side and to bottom frame 2 on the other. More specifically, blade 15 is connected to bucket 10 by an articulated joint 16 (Figures 1 and 4) which, as shown in Figure 4, comprises an intermediate member 18 and a spherical-headed member 19. Intermediate member 18 comprises a shank 20 housed inside a retaining seat in intermediate member 18 and held inside the seat by a pin 21 crosswise to shank 20. Member 18 also comprises a spherical head 22 which projects inside bucket 10 through a hole in the bottom wall 23 of bucket 10, and engages a spherical seat 24 on the inside surface of bottom wall 23.

**[0013]** As shown in Figure 4, an end portion 25, opposite spherical head 22, of intermediate member 18 defines a spherical seat engaged by a spherical head 26 fitted through with a pin 27, the opposite ends of which engage a fork 28 so as to rotate about the axis 27a of pin 27 and slide axially between two axial limit positions.

**[0014]** As shown in Figure 3, blade 15 of implement 14 is connected to bottom frame 2 by a connecting assembly 30 comprising a tubular accessory connecting structure 31 which is substantially U-shaped (Figure 2), is made of welded metal plates, and comprises two longitudinal arms 32 and a front crosspiece 33. Each arm 32 is located outwards of a respective track 3, and has a rear end portion 32a hinged to bottom frame 2 to rotate about a common hinge axis 34 perpendicular to axes 4 and 7 and adjacent to axis 7; and a middle portion 33a of crosspiece 33 is connected to blade 15 by a spherical joint 35.

**[0015]** With reference to Figure 6, joint 35 comprises a milled spherical head 36 which engages a spherical seat defined by a member 36a connected integrally to a rear surface of blade 15, and is integral with a shank 37 welded to a connecting plate connected integrally to portion 33a. In the example shown, spherical head 36 is hinged to member 36a by a hinge pin 38 perpendicular to the bottom edge 15a of blade 15 and to axis 27a. The pin extends inside a through hole 39 formed in head 36 and comprising two portions 39 flaring outwards of the head and of minimum diameter at the centre of head 36. Alternatively, joint 35 has no hinge pin 38, and so functions as an ordinary spherical joint.

**[0016]** With reference to Figure 3, implement 14 also comprises two fixed-length, lateral braces/stays 40 associated with respective arms 32 and so located on opposite sides of and at the same distance from joint 35; and a further fixed-length, lateral brace/stay 41.

**[0017]** Each brace/stay 40 is fitted to a respective bottom lateral end portion 42 of blade 15, adjacent to edge 15a, by a respective joint 43 comprising two hinges with perpendicular axes of rotation. More specifically, each joint 43 comprises an elongated intermediate member 44, one end of which is hinged to a fork 45, connected integrally to relative portion 42, to rotate about an axis 45a perpendicular to axis 27a of pin 27, and the opposite end of which is hinged to a fork 46, on the end of relative brace/stay 40, to rotate about an axis 46a perpendicular to and spaced transversely apart from relative axis 45a.

**[0018]** Each brace/stay 40 is connected to relative arm 32 by a respective flange 47 welded on one side to one end of brace/stay 40, and on the other side to a known spherical joint 48, the spherical head of which has an integral horizontal shank fitted through one of three upward-projecting appendixes 49, each with a hole, welded to and spaced apart along relative arm 32.

**[0019]** Brace/stay 41 extends over one of braces/stays 40, is connected to a top lateral end portion 50 of blade 15 by a joint 51 identical to joint 43, converges with relative brace/stay 40 and relative flange 47, and terminates with a fork 52 hinged to relative flange 47 to rotate about an axis 52a parallel to axes 34 and 46a.

**[0020]** With reference to Figure 3, blade 15 is moved with respect to accessory structure 31 by a double-acting hydraulic jack 55 connected hydraulically to valve 13a by two hoses 56 and located, like brace/stay 41, over a relative brace/stay 40. Jack 55 comprises a cylinder con-

nected to a top lateral end portion 57, opposite portion 50, of blade 15 by a joint 58 identical to joints 43 and 51, converges with relative brace/stay 40 and relative flange 47, and is hinged to flange 47 to rotate about an axis 47a parallel to axes 34 and 46a.

**[0021]** In actual use, starting from the Figure 1 and 2 situation - in which blade 15 is set to a zero or reference position with bottom edge 15a parallel to axis 34 and to the supporting plane P of tracks 3 - the vertical position of blade 15 is controlled by boom 9 and bucket 10, so blade 15 is lifted and lowered by rotating it about axis 34, with its bottom edge 15a parallel to itself at all times.

**[0022]** Regardless of its vertical position, blade 15 of machine 1 can be tilted laterally by rotating it one way or the other between two limit positions, with joint 35 as the fulcrum, so the bottom edge 15a of blade 15 forms a positive or negative angle, and at any rate other than zero, with supporting plane P, as shown by the dash line in Figure 5. Tilting edge 15a is made possible by the geometry and arrangement of joints 43, 48, 58, 35 and 16, and the tilt angle is adjustable by moving the output rod 55a of hydraulic jack 55 forward or backward, and at the same time moving bucket 10 one way or the other parallel to axis 27a and with respect to blade 15. Movement of bucket 10 with respect to blade 15 is made possible by the pin 27-fork 28 connection.

**[0023]** From the zero position of blade 15 shown in Figure 1 and by the continuous line in Figure 2, by disconnecting the pins of joints 48 from appendixes 49 and inserting them inside either of the other appendixes 49 on relative arms 32, blade 15 can be rotated one way or the other about an axis perpendicular to the plane of U-shaped structure 31, with joint 35 still as the fulcrum. Blade 15 can thus be set to various discrete or predetermined positions between two limit positions shown by the dash lines in Figure 2 and symmetrical with respect to the zero position of blade 15.

**[0024]** In a variation not shown, flange 47 of each spherical joint 48 is connected firmly, together with joint 48, to a respective slide, which is moved both ways along relative arm 32 by a relative hydraulic jack connected hydraulically to circuit 13, so that the above adjustment of blade 15 is continuous, i.e. blade 15 can be set to any operating position between said two limit positions.

**[0025]** Unlike known solutions, machine 1 therefore functions as an "excavator", by featuring a classic excavator structure, but at the same time also functions perfectly as a "bulldozer", by featuring an impressive, sturdy accessory structure designed and connected to bottom frame 2 in such a way as to connect blades of the same type normally used on conventional "bulldozers". Likewise, the assembly connecting blade 15 to the accessory connecting structure is equally sturdy and so unaffected by stress transmitted by blade 15.

**[0026]** What is more, accessory implement 14 calls for no additions or alterations to conventional excavators, either as regards mechanical connections or, above all, hydraulic power transmission, since the one actuator for

tilting the blade with respect to the track supporting plane P is fitted to the accessory structure and is simply connected to the existing hydraulic power take-off on articulated boom 9.

**[0027]** Finally, accessory implement 14 can be connected quickly and easily to both bottom frame 2 and bucket 10. With regard to the latter, the particular articulated joint between bucket 10 and blade 15 obviously provides, on the one hand, for simplifying adjustment of blade 15 with respect to accessory structure 31, and, on the other, for highly stable connection of blade 15 to boom 9, even in the presence of severe stress, by being substantially unaffected by the type and direction of the stress transmitted.

**[0028]** The machine described therefore enables a big reduction in both initial investment and maintenance cost, by not only being convertible, but also, when converted, by performing the exact same functions as a conventional special-purpose machine.

**[0029]** Clearly, changes may be made to machine 1 as described herein without, however, departing from the protective scope as defined in the accompanying independent Claims.

#### Claims

1. An accessory pushing implement (14) for a convertible earthmoving machine (1) comprising a self-propelled bottom frame (2) a top frame (5) movable with respect to said bottom frame (2) an articulated boom (9) connected to the top frame (5) and fitted with an implement (10) a main hydraulic circuit for powering said articulated boom (9) and said implement (10) an auxiliary hydraulic circuit (13) for feeding hydraulic fluid to accessory implements (14) connectable to the articulated boom (9), and connecting valve means (13a) fitted to said articulated boom (9); said accessory pushing implement comprising an accessory connecting structure (31) hingeable to said bottom frame (2) to rotate, about a first hinge axis (34) and controllable by said articulated boom (9), between a raised position and a lowered position a front push blade (15) connected to said accessory structure (31) and connecting means (16) on said blade (15) connectable to said implement (14); and **characterized in that** said accessory pushing implement (14) further comprises articulating means (35) interposed between said accessory structure (31) and said blade (15) hydraulic actuating means interposed between said blade (15) and said accessory structure (31) to move the blade (15), with respect to the accessory structure (31), at least about a further hinge axis substantially perpendicular to said first hinge axis (34) and said hydraulic actuating means (55) comprising conduits connectable hydraulically to said connecting valve means (13a) of said articulated boom.
2. An accessory implement (14) as claimed in Claim 1, **characterized in that** said articulating means (35) comprise central spherical joint means; an assembly of lateral stays/braces (40, 41); first connecting joints (43) for connecting each of said stays/braces (40, 41) to said blade (15); and second connecting joints (48) for connecting said stays/braces (40, 41) to said accessory structure (31).
3. An accessory implement (14) as claimed in Claim 1 or 2, **characterized in that** said accessory structure (31) is substantially U-shaped, and comprises two longitudinal arms (32) located on opposite sides of said bottom frame (2).
4. An accessory implement (14) as claimed in one of Claims 1 to 3, **characterized in that** each said first connecting joint (43) comprises first and second hinge means having (45, 46), respectively, a first and second rotation axis (45a, 46a) perpendicular to each other and spaced apart in the transversal direction of the blade.
5. An accessory implement (14) as claimed in Claims 2 to 4, **characterized in that** each said second connecting joint (48) comprises a spherical joint.
6. An accessory implement (14) as claimed in any one of Claims 2 to 5, **characterized in that** each said second connecting joint (48) is movable longitudinally along said accessory structure (31) to adjust the tilt of said blade (15) about a third hinge axis substantially perpendicular to said first hinge axis.
7. An accessory implement (14) as claimed in Claim 6, **characterized in that** said second connecting joints (48) are connectable selectively to discrete points of said accessory structure (31).
8. An accessory implement (14) as claimed in Claim 6, **characterized by** comprising further hydraulic actuating means interposed between each said second connecting joint (48) and said accessory structure (31), to continuously adjust the position of said blade (15) about said third hinge axis.
9. An accessory implement (14) as claimed in Claim 8, **characterized in that** said further hydraulic actuating means are connected hydraulically to said auxiliary hydraulic circuit.
10. An accessory implement (14) as claimed in any one of the foregoing Claims, **characterized in that** said hydraulic actuating means (55) comprise a single hydraulic actuator interposed between said accessory structure (31) and said blade (15).
11. An accessory implement (14) as claimed in Claim

- 10, **characterized in that** said single hydraulic actuator is connected to said accessory structure (31) by a joint (58) comprising first and second hinge means having, respectively, a fourth and fifth hinge axis perpendicular to each other and spaced transversely apart. 5
12. An accessory implement (14) as claimed in any one of the foregoing Claims, **characterized in that** said connecting means (16) comprise spherical joint means. 10
13. An accessory implement (14) as claimed in Claim 12, **characterized in that** said spherical joint means comprise a pair of spherical joints in series. 15
14. An accessory implement (14) as claimed in Claim 13, **characterized in that** said pair of spherical joints comprises a common intermediate member comprising a spherical head of one of said spherical joints, and a spherical seat of the other of said spherical joints; and that said spherical head is connected releasably to said intermediate member; said spherical head engages a spherical seat in said implement. 20 25
15. A convertible earthmoving machine (1) comprising a self-propelled bottom frame (2), a top frame (5) movable with respect to said bottom frame (2), an articulated boom (9) connected to the top frame (5) and fitted with an implement (10), a main hydraulic circuit for powering said articulated boom (9) and said implement (10), an auxiliary hydraulic circuit (13) for feeding hydraulic fluid to accessory implements connectable to the articulated boom (9), connecting valve means fitted to said articulated boom (9) and an accessory pushing implement (14) according to any of the preceding claims. 30 35
2. Anbaugerät (14) nach Anspruch 1, **dadurch gekennzeichnet, dass** die Gelenkeinrichtungen (35) in der Mitte liegende Kugelgelenk-Einrichtungen, eine Anordnung von seitlichen Streben/Stangen (40, 41); erste Verbindungsgelenke (43) zum Verbinden jeder der Streben/Stangen (40, 41) mit der Schaufel (15); und zweite Verbindungsgelenke (48) zum Verbinden der Streben/Stangen (40, 41) mit der Anbaugeräte-Verbindungsstruktur (31) umfassen. 40
3. Anbaugerät (14) nach Anspruch 1 oder 2, **dadurch gekennzeichnet, dass** die Anbaugeräte-Verbindungsstruktur (31) im Wesentlichen U-förmig ist und zwei längs gerichtete Arme (32) umfasst, die auf entgegengesetzten Seiten des unteren Rahmens (2) liegen. 45
4. Anbaugerät (14) nach einem der Ansprüche 1 bis 3, **dadurch gekennzeichnet, dass** jedes erste Verbindungsgelenk (43) erste und zweite Gelenkeinrichtungen (45, 46) umfasst, die jeweils eine erste und eine zweite Drehachse (45a, 46a) unter einem rechten Winkel zueinander und in einem Abstand in der Querrichtung der Schaufel aufweisen. 50
5. Anbaugerät (14) nach den Ansprüchen 2 bis 4, **dadurch gekennzeichnet, dass** jedes zweite Verbindungsgelenk (48) ein Kugelgelenk umfasst. 55
6. Anbaugerät (14) nach einem der Ansprüche 2 bis 5, **dadurch gekennzeichnet, dass** jedes der Verbindungsgelenke (48) in Längsrichtung entlang der Anbaugeräte-Verbindungsstruktur (31), die gelenkig mit dem unteren Rahmen (2) verbindbar ist, um sich um eine erste Gelenkachse (34) zu drehen, und die durch den gelenkig befestigten Ausleger (9) zwischen einer angehobenen Position und einer abgesenkten Position bewegbar ist, eine vordere Planierschaufel (15), die mit der Anbaugeräte-Verbindungsstruktur (31) verbunden ist, und Verbindungseinrichtungen (16) auf der Schaufel (15), die mit dem Arbeitsgerät (14) verbindbar sind; und **dadurch gekennzeichnet, dass** das Planierzusatz-Anbaugerät (14) weiterhin Gelenkeinrichtungen (35) umfasst, die zwischen der Anbaugeräte-Verbindungsstruktur (31) und der Schaufel (15) eingefügt sind, wobei hydraulische Betätigungseinrichtungen zwischen der Schaufel (15) und der Anbaugeräte-Verbindungsstruktur (31) eingefügt sind, um die Schaufel (15) gegenüber der Anbaugeräte-Verbindungsstruktur (31) um zumindest eine weitere Gelenkachse zu bewegen" die im Wesentlichen unter einem rechten Winkel zu der ersten Gelenkachse (34) steht, und wobei die hydraulischen Betätigungseinrichtungen (55) Leitungen umfassen, die hydraulisch mit den Verbindungsventil-Einrichtungen (13a) des gelenkig befestigten Auslegers verbindbar sind. 5

## Patentansprüche

1. Planierzusatz-Anbaugerät (14) für eine konvertierbare Erdbewegungsmaschine (1) mit einem selbst fahrenden unteren Rahmen (2), einem oberen Rahmen (5), der gegenüber dem unteren Rahmen (2) beweglich ist, einem gelenkig befestigten Ausleger (9), der mit dem oberen Rahmen (5) verbunden und mit einem Arbeitsgerät (10) versehen ist, einem Haupt-Hydraulikkreis zur Versorgung des gelenkig befestigten Auslegers (9) und des Arbeitsgerätes (10) mit Leistung, einem Hilfs-Hydraulikkreis (13) zum Zuführen von Hydraulikflüssigkeit zu Anbaugeräten (14), die mit dem gelenkig befestigten Ausleger (9) verbindbar sind, um mit Verbindungsventil-Einrichtungen (13a), die an dem gelenkig befestigten Ausleger (9) angebracht sind, wobei das Planierzusatz-Anbaugerät Folgendes umfasst: eine Anbau- 50 55

- baugeräte-Struktur (31) beweglich ist, um die Neigung der Schaufel (15) um eine dritte Gelenkachse einzustellen, die im Wesentlichen unter einem rechten Winkel zu der ersten Gelenkachse steht.
7. Anbaugerät (14) nach Anspruch 6, **dadurch gekennzeichnet, dass** die zweiten Verbindungsgelenke (48) selektiv mit diskreten Punkten der Anbaugeräte-Struktur (31) verbindbar sind.
8. Anbaugerät (14) nach Anspruch 6, **dadurch gekennzeichnet, dass** es weitere hydraulische Betätigungseinrichtungen umfasst, die zwischen jedem der zweiten Verbindungsgelenke (48) und der Anbaugeräte-Verbindungsstruktur (31) eingefügt sind, um kontinuierlich die Position der Schaufel (15) um die dritte Gelenkachse einzustellen.
9. Anbaugerät (14) nach Anspruch 8, **dadurch gekennzeichnet, dass** die weiteren hydraulischen Betätigungseinrichtungen hydraulisch mit dem Hilfs-Hydraulikkreis verbunden sind.
10. Anbaugerät (14) nach einem der vorhergehenden Ansprüche, **dadurch gekennzeichnet, dass** die hydraulischen Betätigungseinrichtungen (55) ein einfach wirkendes hydraulisches Stellglied umfassen, das zwischen der Anbaugeräte-Struktur (31) und der Schaufel (15) eingefügt ist.
11. Anbaugerät (14) nach Anspruch 10, **dadurch gekennzeichnet, dass** das einfach wirkende hydraulische Stellglied mit der Anbaugeräte-Struktur (31) durch ein Gelenk (58) verbunden ist, das erste und zweite Gelenkeinrichtungen umfasst, die jeweils eine vierte und eine fünfte Gelenkachse unter einem rechten Winkel zueinander aufweisen und in Querrichtung in Abstand voneinander angeordnet sind.
12. Anbaugerät (14) nach einem der vorhergehenden Ansprüche, **dadurch gekennzeichnet, dass** die Verbindungseinrichtungen (16) Kugelgelenk-Einrichtungen umfassen.
13. Anbaugerät (14) nach Anspruch 12, **dadurch gekennzeichnet, dass** die Kugelgelenk-Einrichtungen ein Paar von Kugelgelenken in Serie umfassen.
14. Anbaugerät (14) nach Anspruch 13, **dadurch gekennzeichnet, dass** das Paar von Kugelgelenken ein gemeinsames Zwischenelement umfasst, das einen kugelförmigen Kopf von einem der Kugelgelenke und einen kugelförmigen Sitz des anderen der kugelförmigen Gelenke umfasst, und dass der kugelförmige Kopf lösbar mit dem Zwischenelement verbunden ist, wobei der kugelförmige Kopf mit einem kugelförmigen Sitz in dem Arbeitsgerät in Eingriff steht.

15. Konvertierbare Erdbewegungsmaschine (1), mit einem selbst fahrenden unteren Rahmen (2), einem oberen Rahmen (5), der gegenüber dem unteren Rahmen (2) beweglich ist, einen gelenkig befestigten Ausleger (9), der mit dem oberen Rahmen (5) verbunden und mit einem Arbeitsgerät (10) versehen ist, einem Haupt-Hydraulikkreis zur Versorgung des gelenkig befestigten Auslegers (9) und des Arbeitsgerätes (10) mit Leistung, einem Hilfs-Hydraulikkreis (13) zum Zuführen von Hydraulikflüssigkeit an Anbaugeräte (14), die mit dem gelenkig befestigten Ausleger (9) verbindbar sind, und Verbindungsventil-Einrichtungen, die an dem gelenkig befestigten Ausleger (9) angebracht sind, und einem Planierzusatz-Anbaugerät (14) nach einem der vorhergehenden Ansprüche.

### Revendications

1. Outil de poussée auxiliaire (14) pour un engin de terrassement convertible (1) comprenant un châssis-plancher automoteur (2), un châssis supérieur (5) mobile par rapport audit châssis-plancher (2), une flèche articulée (9) reliée au châssis supérieur (5) et équipée d'un outil (10), un circuit hydraulique principal pour actionner ladite flèche articulée (9) et ledit outil (10), un circuit hydraulique auxiliaire (13) destiné à alimenter du fluide hydraulique à des outils auxiliaires (14) pouvant être reliés à la flèche articulée (9), et un dispositif de soupape de raccordement (13a) installé sur la flèche articulée (9), ledit outil de poussée auxiliaire comprenant une structure de liaison auxiliaire (31) pouvant être articulée sur ledit châssis-plancher (2) pour tourner autour d'un premier axe de charnière (34) et pouvant être commandée par ladite flèche articulée (9), entre une position soulevée et une position abaissée, une lame de poussée frontale (15) connectée à ladite structure auxiliaire (31), et un dispositif de liaison (16) sur ladite lame (15) pouvant être accouplé au dit outil (14), et
- caractérisé en ce que** ledit outil de poussée auxiliaire (14) comprend en plus un moyen d'articulation (35) intercalé entre ladite structure auxiliaire (31) et ladite lame (15) et des moyens d'actionnement hydrauliques intercalés entre ladite lame (15) et ladite structure auxiliaire (31) pour déplacer la lame (15) par rapport à la structure auxiliaire (31), au moins autour d'un autre axe de charnière sensiblement perpendiculaire au dit premier axe de charnière (34), lesdits moyens d'actionnement hydrauliques (55) comprenant des conduits hydrauliquement connectables au dit dispositif de soupape de raccordement (13a) de la dite flèche articulée.
2. Outil auxiliaire (14) selon la revendication 1, **caractérisé en ce que** ledit moyen d'articulation (35) com-

- prend un moyen central d'articulation à rotule, un ensemble de renforts / tirants latéraux (40, 41), des premières articulations de liaison (43) pour relier chacun des dits renforts / tirants (40, 41) à ladite lame (15), et des dites secondes articulations de liaison (48) pour relier les dits renforts / tirants (40, 41) à ladite structure auxiliaire (31).
3. Outil auxiliaire (14) selon la revendication 1 ou 2, **caractérisé en ce que** ladite structure auxiliaire (31) est sensiblement en forme de U, et comprend deux bras longitudinaux (32) situés à des côtés opposés du dit châssis-plancher (2). 5
  4. Outil auxiliaire (14) selon l'une quelconque des revendications 1 à 3, **caractérisé en ce que** chaque dite première articulation de liaison (43) comprend des premier et second moyens de charnière (45, 46) comportant respectivement un premier et un second axes de rotation (45a, 46a) perpendiculaires l'un à l'autre et espacés dans le sens transversal de la lame. 10
  5. Outil auxiliaire (14) selon les revendications 2 à 4, **caractérisé en ce que** chaque dite seconde articulation de liaison (48) comprend une articulation à rotule. 15
  6. Outil auxiliaire (14) selon l'une quelconque des revendications 2 à 5, **caractérisé en ce que** chaque dite seconde articulation de liaison (48) est mobile longitudinalement le long de ladite structure auxiliaire (31) pour ajuster l'inclinaison de ladite lame (15) autour d'un troisième axe de charnière sensiblement perpendiculaire au dit premier axe de charnière. 20
  7. Outil auxiliaire (14) selon la revendication 6, **caractérisé en ce que** chaque dite seconde articulation de liaison (48) sont connectables sélectivement à des points discrets de ladite structure auxiliaire (31). 25
  8. Outil auxiliaire (14) selon la revendication 6, **caractérisé en ce que** qu'il comprend des moyens d'actionnement hydraulique additionnels intercalés entre chaque dite seconde articulation de liaison (48) et ladite structure auxiliaire (31), pour ajuster continuellement la position de ladite lame (15) autour du dit troisième axe de charnière. 30
  9. Outil auxiliaire (14) selon la revendication 8, **caractérisé en ce que** ces moyens d'actionnement hydraulique additionnels sont connectés hydrauliquement au dit circuit hydraulique auxiliaire. 35
  10. Outil auxiliaire (14) selon l'une quelconque des revendications précédentes, **caractérisé en ce que** ces moyens d'actionnement hydraulique (55) comprennent un actionneur hydraulique à simple effet 40
  - intercalé entre ladite structure auxiliaire (31) et ladite lame (15). 45
  11. Outil auxiliaire (14) selon la revendication 10, **caractérisé en ce que** ledit actionneur hydraulique à simple effet est relié à ladite structure auxiliaire (31) par une articulation (58) comprenant des premier et second moyens de charnière ayant, respectivement, un quatrième et un cinquième axe de charnière perpendiculaires l'un à l'autre et espacés transversalement. 50
  12. Outil auxiliaire (14) selon l'une quelconque des revendications précédentes, **caractérisé en ce que** ledit dispositif de liaison (16) comprend un moyen d'articulation à rotule. 55
  13. Outil auxiliaire (14) selon la revendication 12, **caractérisé en ce que** ledit moyen d'articulation à rotule comprend une paire d'articulations à rotule en série.
  14. Outil auxiliaire (14) selon la revendication 13, **caractérisé en ce que** ladite paire d'articulations à rotule comprend un membre commun intermédiaire comportant une tête sphérique d'une des dites articulations à rotule et un siège sphérique de l'autre des dites articulations à rotule, et **en ce que** ladite tête sphérique est reliée de façon amovible au dit membre intermédiaire et la tête sphérique engage un siège sphérique dans ledit outil.
  15. Engin de terrassement convertible (1) comprenant un châssis-plancher automoteur (2), un châssis supérieur (5) mobile par rapport audit châssis-plancher (2), une flèche articulée (9) reliée au châssis supérieur (5) et équipée d'un outil (10), un circuit hydraulique principal pour actionner ladite flèche articulée (9) et ledit outil (10), un circuit hydraulique auxiliaire (13) destiné à alimenter du fluide hydraulique à des outils auxiliaires (14) pouvant être reliés à la flèche articulée (9), un dispositif de soupape de raccordement installé sur la flèche articulée (9) et un outil de poussée auxiliaire (14) selon l'une quelconque des revendications précédentes.

FIG. 1

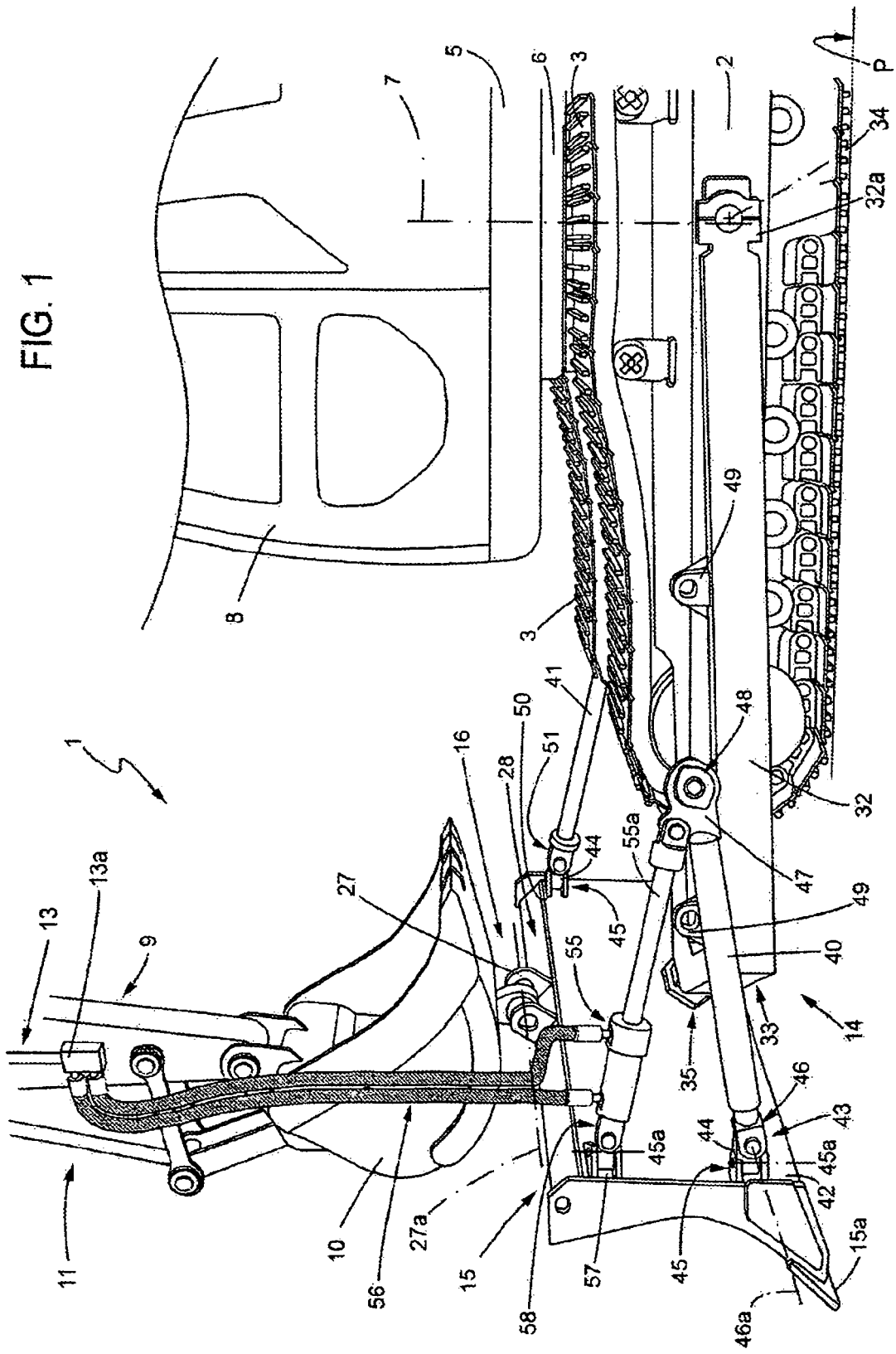

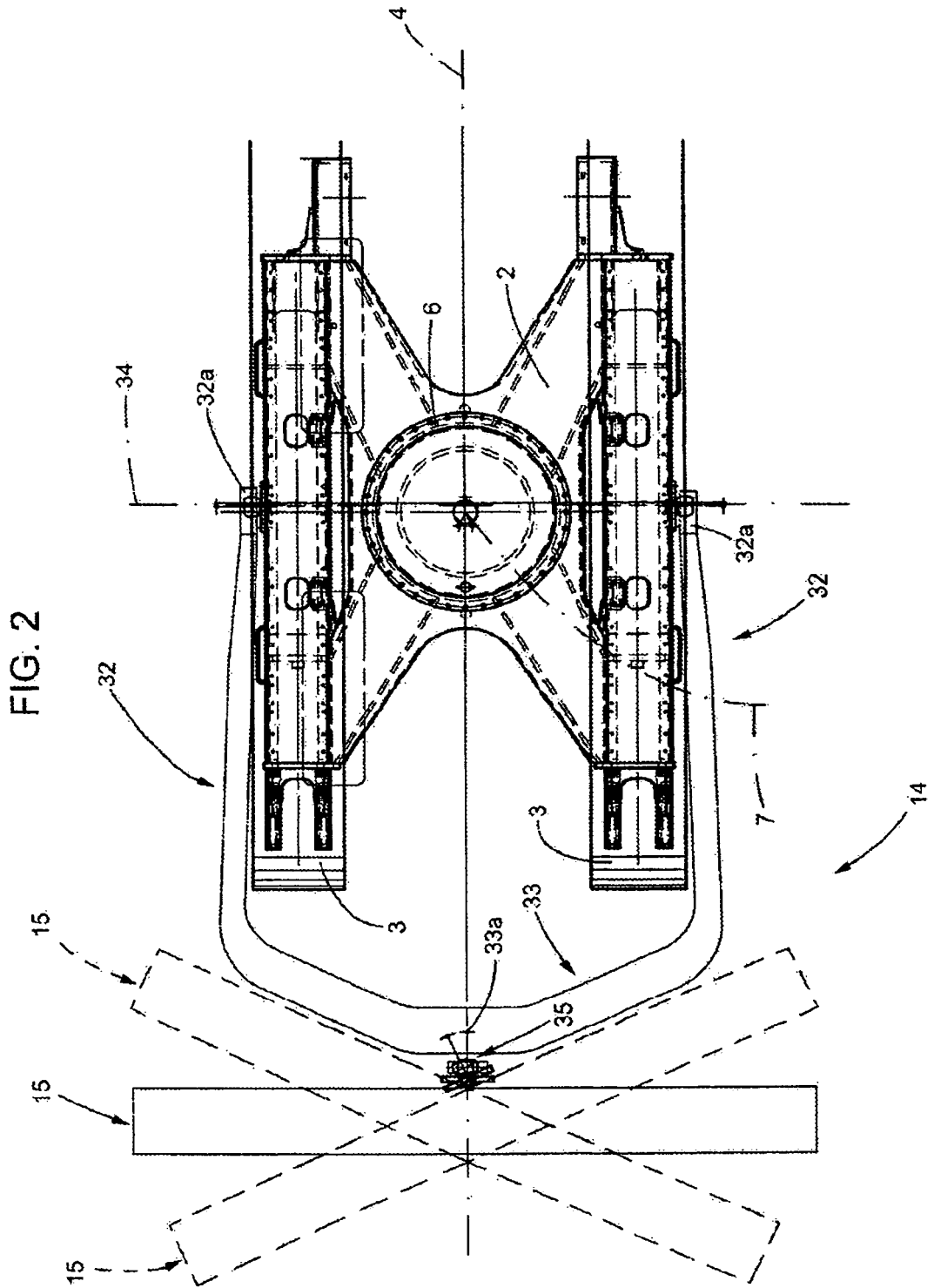

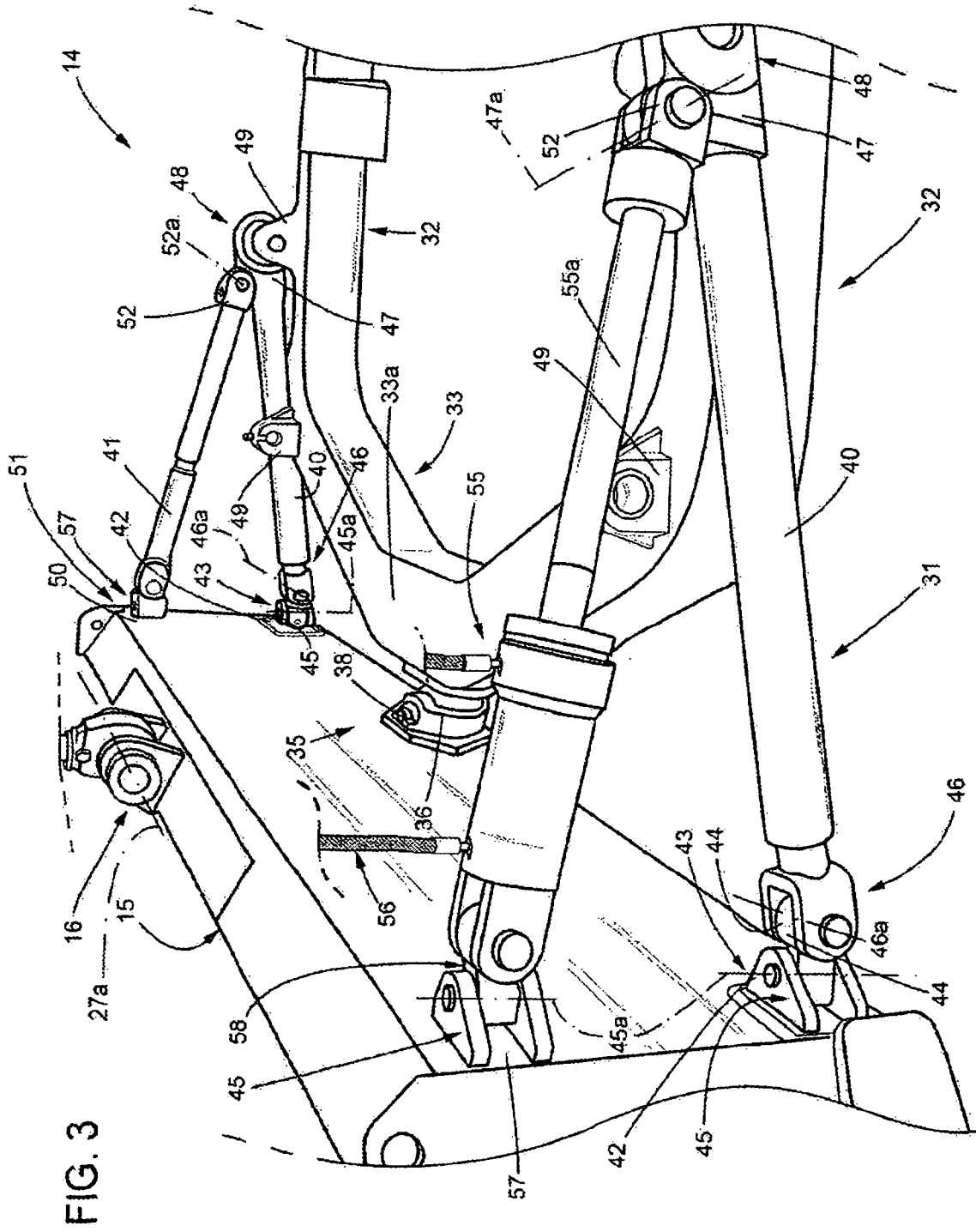

FIG. 4

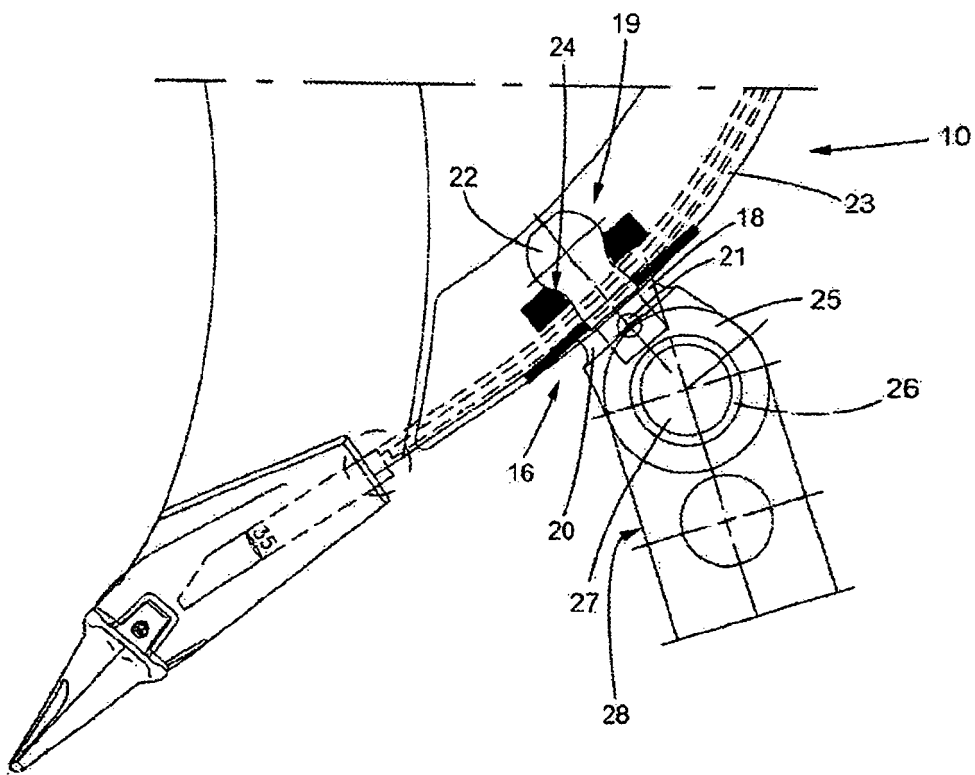
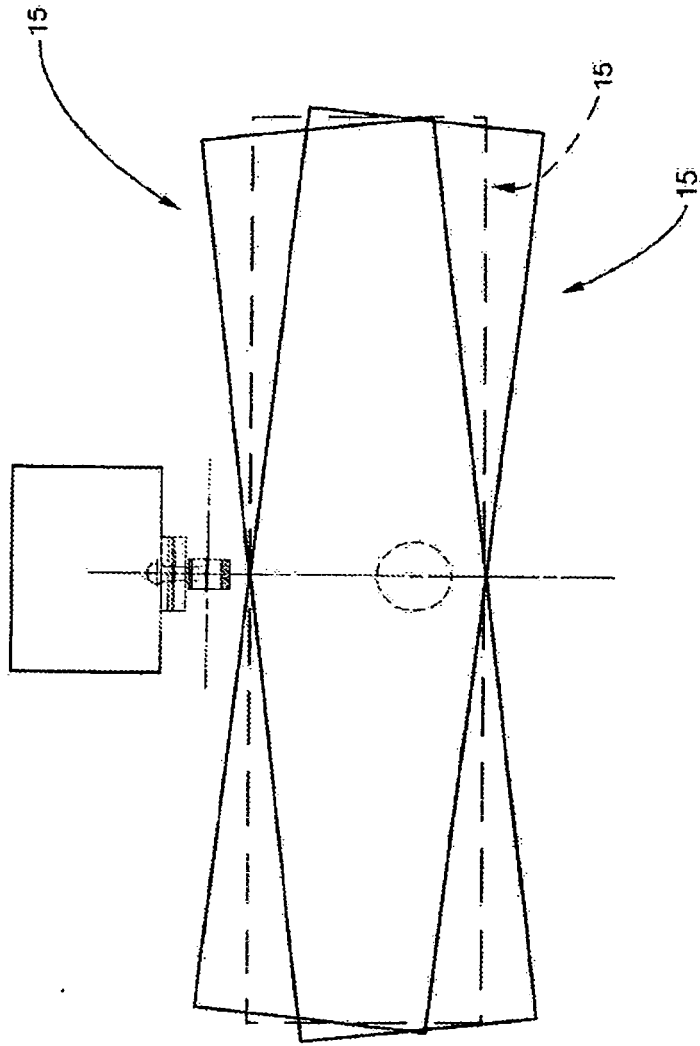
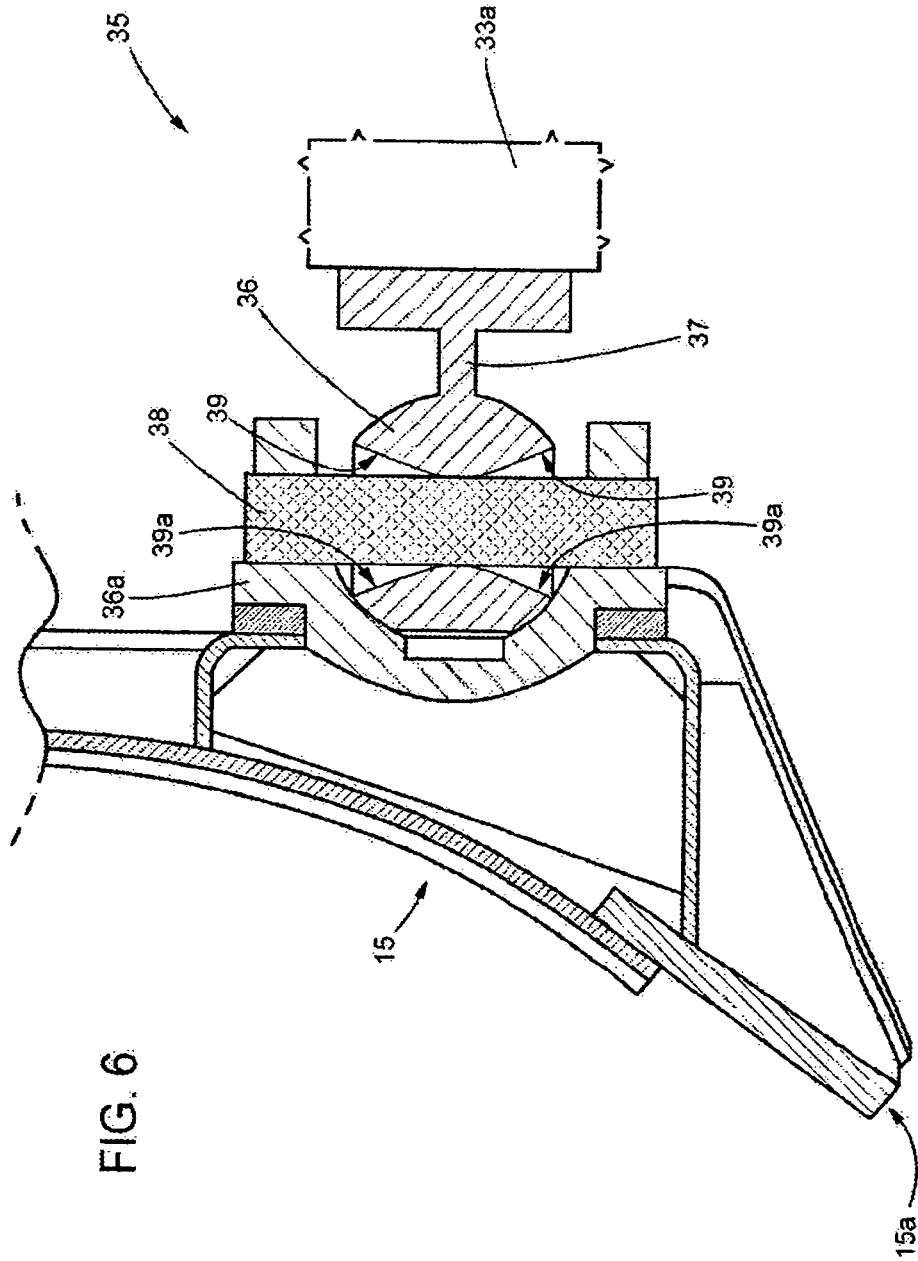

FIG. 5





**REFERENCES CITED IN THE DESCRIPTION**

*This list of references cited by the applicant is for the reader's convenience only. It does not form part of the European patent document. Even though great care has been taken in compiling the references, errors or omissions cannot be excluded and the EPO disclaims all liability in this regard.*

**Patent documents cited in the description**

- GB 2341167 A [0005]
- JP 4017446 U [0006]