

(21) Application No 8513087
 (22) Date of filing 23 May 1985
 (30) Priority data
 (31) 59/108806 (32) 29 May 1984 (33) JP

(51) INT CL⁴
 H05B 6/12 G04C 17/00 G09G 3/00

(52) Domestic classification
 G5C A342 A361 HA
 G3N 277D 404 381 G1A
 G3T 101 302 303 308 406 RA
 U1S 2400 G3N G3T G5C

(71) Applicant
 Kabushiki Kaisha Toshiba (Japan),
 72 Horikawa-cho, Saiwai-ku, Kawasaki-shi, Japan

(56) Documents cited
 GB 1569516 EP A1 0056335 EP A2 0027711

(72) Inventor
 Hisao Karino

(58) Field of search
 G5C
 G3N
 G1A
 G3T

(74) Agent and/or Address for Service
 Marks and Clerk,
 57-60 Lincoln's Inn Fields, London WC2A 3LS

(54) Cooking apparatus

(57) A cooking apparatus has a heating chamber (2a) with a plurality of cooking modes, cooking information setting means (22, 5) for setting at least one of the cooking modes and cooking information including a cooking time, displaying means (11) having a display element (19) for performing graphic display of at least time elapsed information of the cooking information in accordance with a plurality of colors respectively corresponding to the plurality of cooking modes, first control means (20, 23) for designating a given heating function in the heating chamber (2a) in accordance with the set cooking information and controlling at least a cooking drive time required for the given heating function, and second control means (20, 21) for calculating the time elapsed information to drive at least the graphic display element (19) in the cooking information display means (11) and for designating a color for the time elapsed information in accordance with a type of cooking mode. The display may include LED or LCD elements.

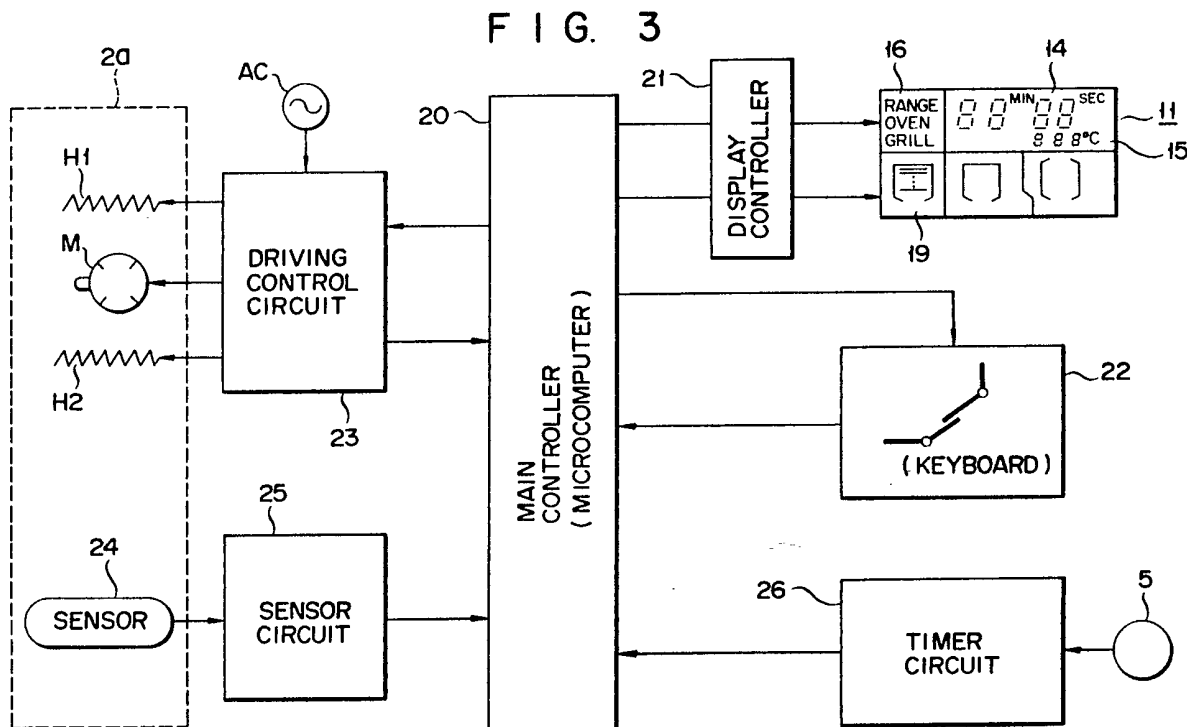

1/4

FIG. 1

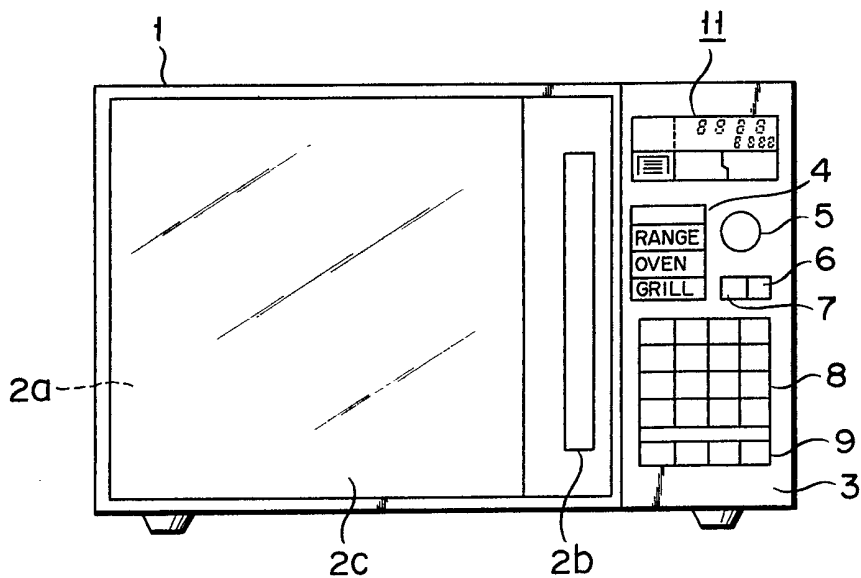

FIG. 2

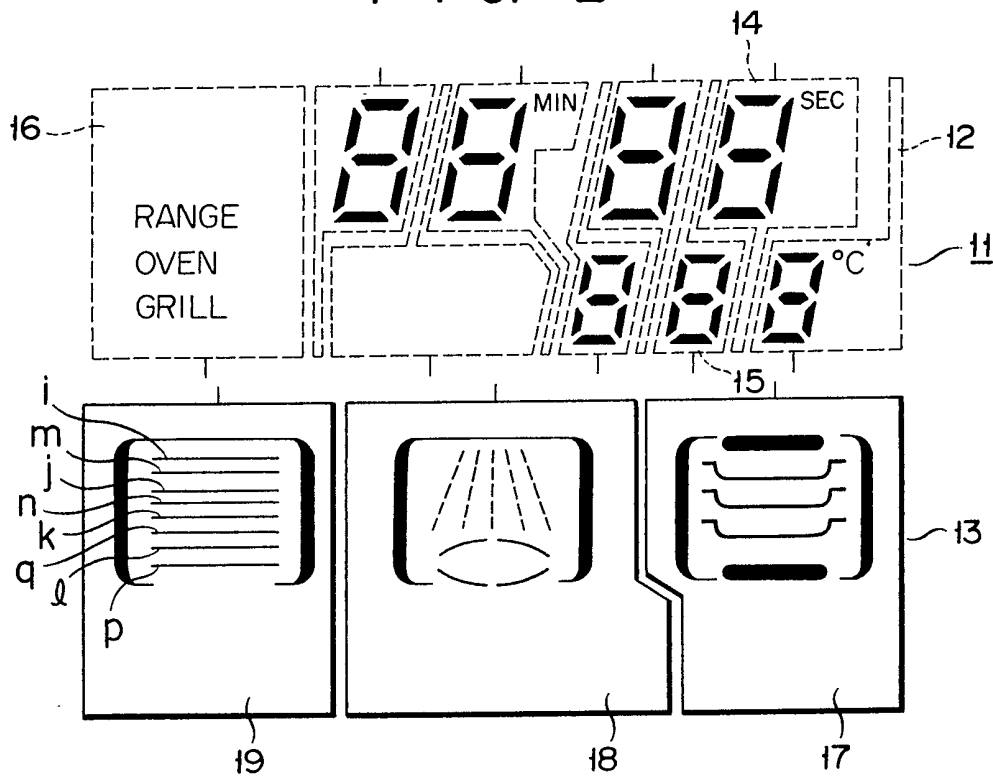

FIG. 3

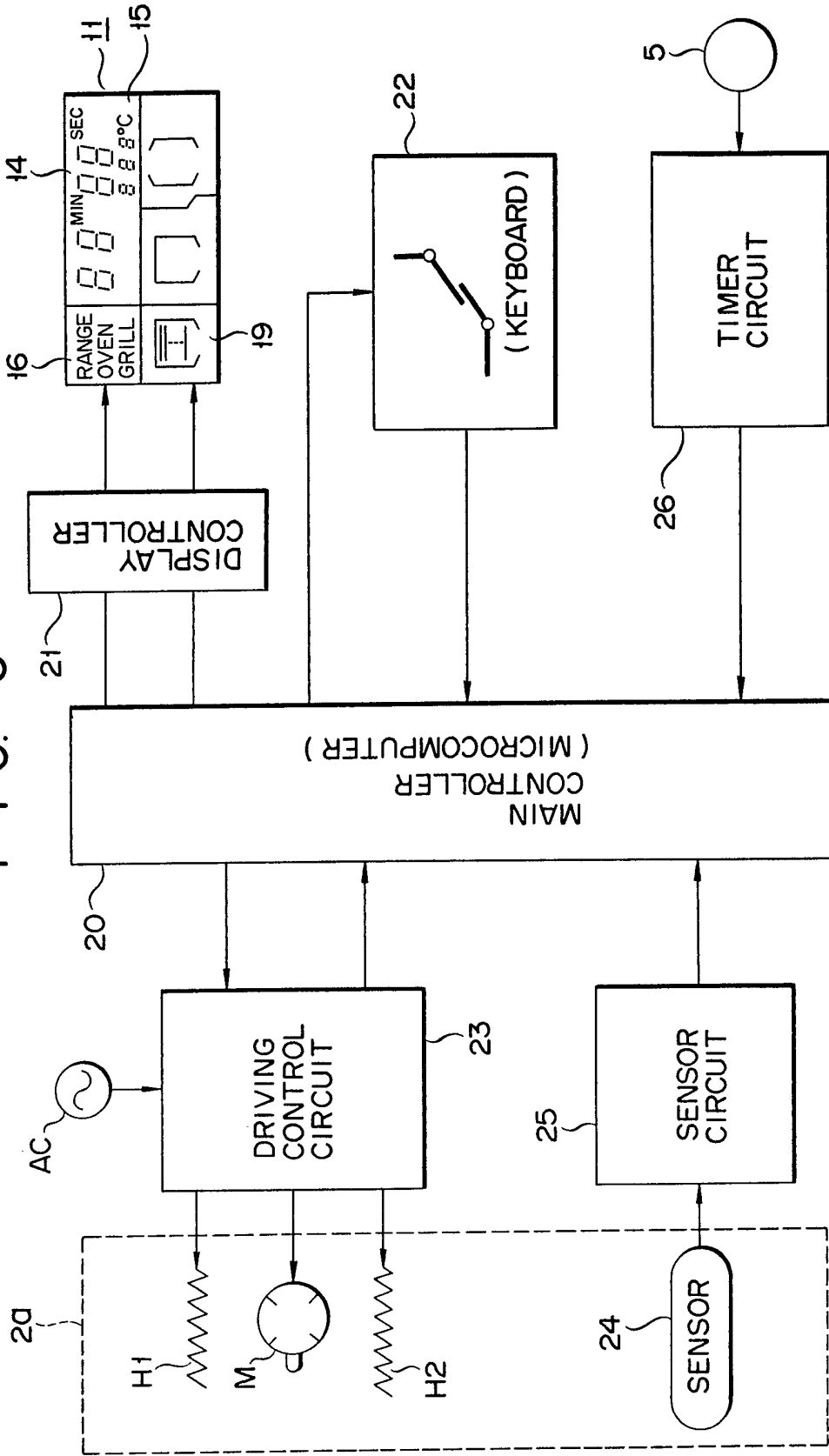

FIG. 4

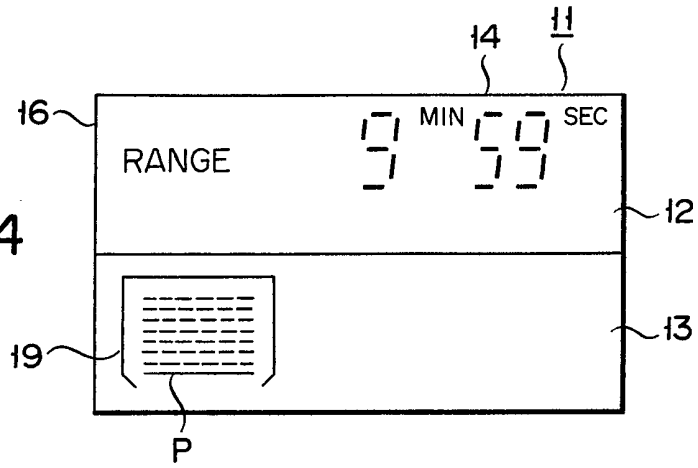

FIG. 5

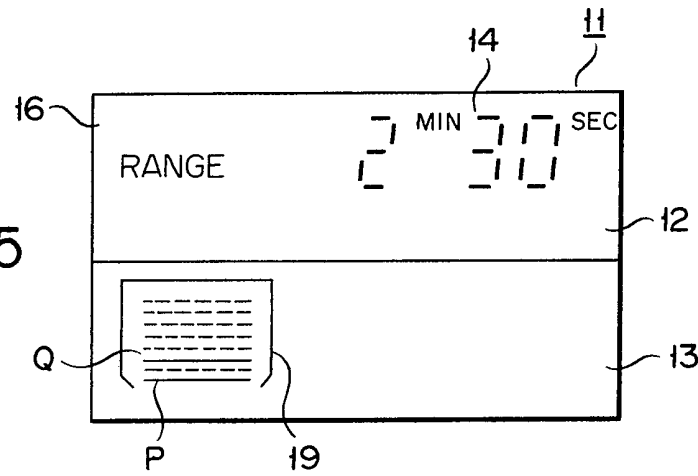

FIG. 6

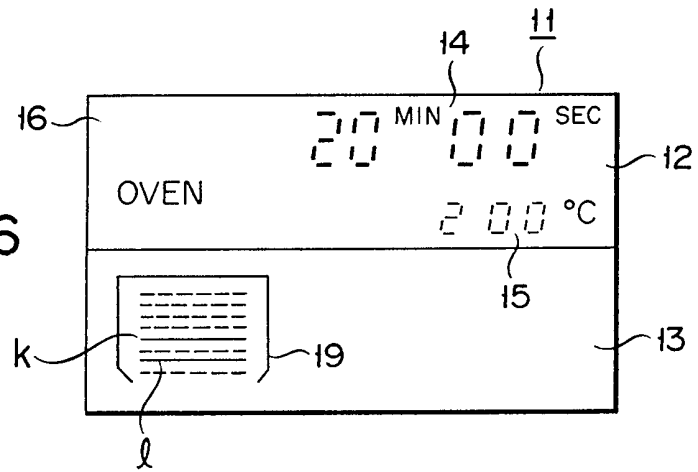

FIG. 7

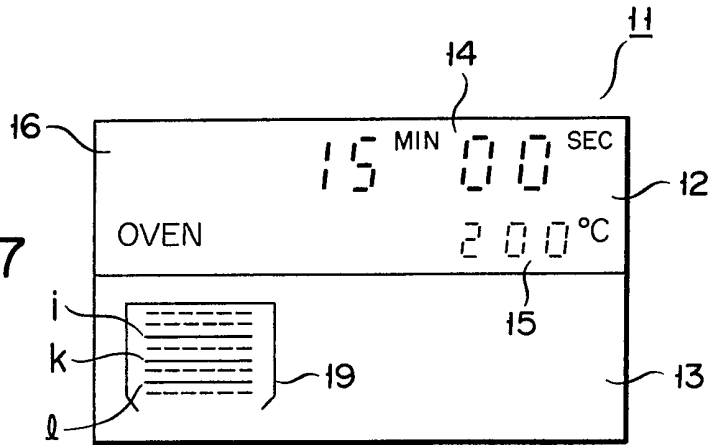
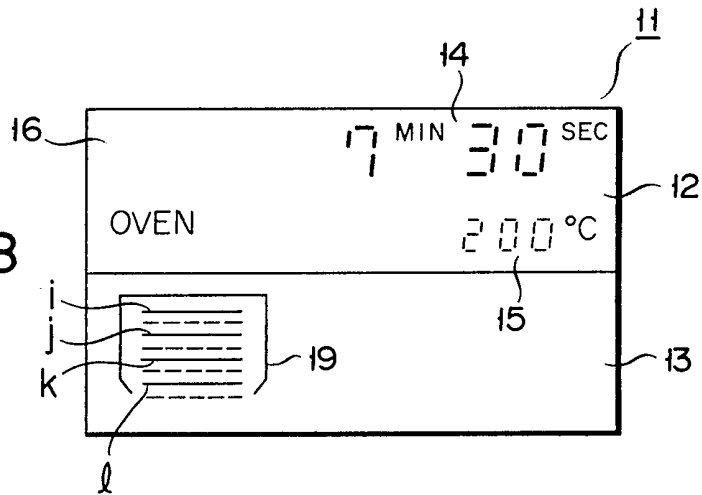

FIG. 8



SPECIFICATION

Cooking apparatus

5 This invention relates to a cooking apparatus and, more particularly, to an improvement of the display device of a cooking apparatus having a plurality of cooking modes.

10 A conventional cooking apparatus is known wherein food can be heated or cooked in a heating chamber of a housing in accordance with a plurality of heating functions such as an oven function, a grill function and a microwave range oven function.

15 In a cooking apparatus of this type, a digital display device, for example, is usually arranged in an operation panel adjacent to a front door of the heating chamber in the housing to digitally display, for example, remaining cooking time on the display device during cooking. In this case, a cooking set time is digitally displayed at the beginning of cooking. The display contents are decremented every one second as the time elapses.

25 When the food is cooked, the display content is zero.

In the conventional arrangement described above, a user cannot check a cooking state at a desired moment in order to know how many minutes of the total preset time have elapsed, resulting in inconvenience. In addition, when a user wishes to perform sequential cooking of food by combining, e.g., the microwave oven range function and the oven or grill

35 function, the user cannot check at once how many minutes of the total preset time have elapsed, resulting in inconvenience.

It is, therefore, an object of the present invention to provide a new and improved cooking apparatus in which effective display operations are performed so that a user can immediately check at a desired moment how many minutes have elapsed in a single cooking mode selected among a plurality of cooking modes, and can also immediately check at a desired moment how many minutes of the total cooking time have elapsed when a plurality of cooking modes are continuously performed in combination during sequential cooking, and also can easily identify each cooking mode.

According to the present invention, a cooking apparatus comprises:

55 a heating chamber having a plurality of heating functions so as to cook food in accordance with a plurality of cooking modes;

cooking information setting means for setting at least one of the cooking modes and cooking information including a cooking time;

60 cooking information displaying means having a display element for performing graphic display of at least time elapsed information of the set cooking information in accordance with a plurality of colors respectively corresponding to the plurality of cooking modes;

65

first control means for designating a given heating function in the heating chamber in accordance with the set cooking information and for controlling at least a cooking drive time required for the given heating function; and

70 second control means for calculating the time elapsed information to drive at least the graphic display element in the cooking information display means and for designating a color for the time elapsed information in accordance with the type of cooking mode.

These and other objects and features of the present invention can be understood by reference to the accompanying drawings, in which:

80 *Figure 1* is a front view of a cooking apparatus according to an embodiment of the present invention;

85 *Figure 2* is a detailed view of a display device of Fig. 1;

Figure 3 is a block diagram of a control circuit of the apparatus shown in Fig. 1; and

90 *Figures 4 to 8* are respectively representations showing display states of the display device so as to explain the operation of the apparatus shown in Fig. 1.

Fig. 1 is a front view of a cooking apparatus, with a plurality of cooking functions, as a so-called oven/grill (electronic) range according to an embodiment of the present invention. A housing 1 comprises a heating chamber 2a having a plurality of heating functions corresponding to a plurality of cooking modes such as an oven function, a grill function and a microwave oven range function, and a door 2c held by a handle 2b to close/open the heating chamber 2a. An operation panel 3 is arranged in the right portion of the housing 1.

105 In addition to a display device 11 (to be described later), the operation panel 3 has a plurality of cooking mode selection keys 4, a timer dial 5, a cooking start key 6, a cooking stop key 7, a plurality of cooking item keys 8, and cooking temperature keys 9 arranged from the upper portion to the lower portion thereof.

Fig. 2 shows a detailed arrangement of the display device 11. The device 11 comprises a first display section 12 and a second display section 13. The section 12 has digital display units 14 and 15 for digitally displaying cooking information such as a preset cooking time, a remaining cooking time and a cooking temperature, and a cooking mode display unit 16 for displaying a cooking mode with letters such as "OVEN", "GRILL" and "RANGE". The section 13 comprises graphic display units for displaying different cooking modes by corresponding illustrations. More particularly, the section 13 has a tray position display unit 17 for displaying a cooking tray position in the heating chamber, a microwave oven range cooking state display unit 18 for displaying a microwave oven range cooking state and a

115

120

125

130

bar display unit 19 for displaying a type of cooking mode and an elapsed cooking time, i.e., a cooking state. Eight indicator bars (display elements) i, m, j, n, k, Q, l and p made of fluorescent lamps or light-emitting diodes are vertically arrayed parallel to each other. Among the bars i to p, the bars i, j, k and l are constituted by red segments for emitting red light, and the bars m, n, Q and p are constituted by green segments for emitting green light. The red and green segments are alternately arranged along the vertical direction.

Fig. 3 shows a control circuit built into the housing 1. A main controller 20 comprises a microcomputer having an internal memory for storing a program for predetermined control (to be described later). The controller 20 is connected to the device 11 through a display controller 21 including a decoder function. A segment signal and a digit signal are supplied from the controller 20 to the device 11 through the controller 21, and the device 11 is turned on or off in accordance with control (to be described later) of a combination of the segment and digit signals. In this case, the controller 21 causes the device 11 to display data "0000" to alarm a power failure. A keyboard (matrix switch pad) 22 including the various keys on the operation panel 3 (Fig. 1) of the housing 1 is connected to the controller 20. The keyboard 22 receives the digit signal from the controller 20. A key input signal corresponding to a predetermined keying operation is supplied from the keyboard 22 to the controller 20. The controller 20 is also connected to a driving control circuit 23 for controlling the oscillation of a microwave oven range function magnetron M and the ON/OFF operation of upper and lower heaters H1 and H2 respectively serving as the oven and grill function heaters. In response to the key input signal from the keyboard 22, the controller 20 sets the corresponding cooking mode. When the key 6 is turned on after the cooking time is preset, the controller 20 causes the units 14 and 15 in the device 11 to display numerical data such as the preset cooking time, the remaining cooking time and the cooking temperature. The controller 20 also causes the unit 16 to display letters corresponding to the selected heating function. When the cooking time gradually elapses, the ON/OFF states of the bars i to p in the unit 19 are sequentially updated, thereby signaling to the user that the elapsed time corresponds to the number of ON bars i to p. In addition, when sequential cooking is performed wherein heating and cooking are performed in a combination of a plurality of heating functions, the elapsed time with respect to the total preset time is indicated so that the display color in the unit 19 is changed every time the heating function is changed.

The controller 20 is connected through a sensor circuit 25 to a sensor 24 arranged at a predetermined position in the heating chamber 2a in the housing 1 so as to detect the temperature. The controller 20 is also connected to a timer circuit 26 for receiving the time information set by the dial 5 arranged on the panel 3 in the housing 1.

The controller 20 and the circuit 23 control an output level of the magnetron M in predetermined steps upon operation of a magnetron output level selection key (not shown). The controller 20 and the circuit 23 cooperate with the sensor 24 and the sensor circuit 25 to control heat radiated from the heater H1 (in the grill function mode) or the heaters H1 and H2 (in the oven function mode).

The operation of the microwave oven range having the arrangement described above will be described hereinafter. When the user enters the type of heating function, the cooking time, and the cooking temperature at the keyboard 22 and with the dial 5, a key input signal corresponding to the operation of the keyboard 22 is directly supplied to the main controller 20 and the time set signal is supplied thereto through the timer circuit 26. The signals received by the controller 20 are supplied to the device 11 through the controller 21. The heating function, the cooking time and the cooking temperature are digitally displayed on the units 16, 14 and 15, respectively. In this state, when the key 6 is turned on, the circuit 23 is controlled on the basis of the heating information (i.e., the type of heating function, the preset cooking time and the cooking temperature) received by the controller 20, and the magnetron M, the heater H1 or heaters H1 and H2 are driven by the circuit 23. When the preset cooking time gradually decreases, the cooking time display at the unit 14 is decremented every one second. When the heating function selected is, for example, the microwave oven range function, the green bar p in the unit 19 is turned on at the beginning of cooking. Thereafter, when the controller 20 determines that a period which is 1/4 of the total cooking time has elapsed, the bars p and Q are simultaneously turned on. When the controller 20 determines that a period which is 2/4 of the total cooking time has elapsed, the bars p, Q and n are turned on. When periods which are 3/4 and 4/4 of the total cooking time have elapsed, the bars p, Q and n and the bars p, Q, n and m are turned on, respectively. When the controller 20 determines that cooking is completed, the controller 20 causes the unit 14 to display zero cooking time. At the same time, the controller 20 controls the unit 19 to turn off all the bars in the unit 19. When the heating function is the oven function or the grill function, the red bars l, k, j and i are sequentially turned on as the actual cooking time increases. The green bars p, Q, n and m are

kept OFF. When cooking is completed, the controller 20 causes the bars p to i to turn off. The ON/OFF operation of the bars is reversed when the heating function is the microwave oven range.

5 Assume that sequential cooking (two-mode cooking) is performed so that food is cooked in the microwave oven range function for 10 minutes and is then heated in the oven function (or the grill function) for 20 minutes, thereby continuously cooking the food for a total time of 30 minutes. The controller 20 controls so that the microwave oven range function "RANGE" is displayed on the unit 16 in the device 11. At the same time, the preset cooking time (i.e., 10 minutes) in the microwave oven range function is digitally displayed on the unit 14. When the key 6 is turned on, the content of the cooking time displayed on the unit 14 is controlled so as to be decremented every one second in accordance with time control and arithmetic operation of the controller 20. The controller 20 also controls to turn on only the green bar p of the unit 19, as shown in Fig. 4, immediately after cooking is started (e.g., when the remaining time is about 9 minutes and 59 seconds in the microwave oven range function). When the remaining cooking time is two minutes and 30 seconds in the microwave oven range function, and the controller 20 determines that 1/4 of the total cooking time is remaining, the controller 20 causes the bars p and Q in the unit 19 to turn on, as shown in Fig. 5. When the controller 20 switches the microwave oven range function to the oven function after the controller 20 has determined that 10 minutes have elapsed, the oven function "OVEN" is displayed on the display 16, and the preset cooking time (i.e., 20 minutes in the oven function mode) is digitally displayed on the unit 14, as shown in Fig. 6. The controller 20 then turns off the green bars p and Q in the unit 19, and then the red bars l and k are turned on. In this state, cooking in the oven function mode continues. When the remaining time of the oven function cooking is 15 minutes and the controller 20 determines that the total elapsed time is 2/4 of the total cooking time in the sequential cooking mode, the controller 20 turns on the red bars l, k and j in the unit 19. When the controller 20 determines that the remaining time of the oven function mode is 7 minutes and 30 seconds, and that the total elapsed time of sequential cooking is 3/4, the red bars l, k, j and i in the unit 19 are turned on. When the controller 20 determines that the oven function time is zero and sequential cooking is completed, the controller 20 causes all the bars p to i to turn off.

65 In the microwave oven range with the above operation, when single heating cooking (i.e., single mode cooking) is performed, the number of bars turned on in the unit 19 is

70 changed. More specifically, when the microwave oven range function is performed, the main controller controls to sequentially turn on the green bars p, Q, n and m. When the oven or grill function is performed, the main controller controls to sequentially turn on the red bars l, k, j and i. At any moment during cooking, the user can check the cooking state (i.e., the elapsed time of the total cooking time) by visually observing the number of bars turned on. In addition, by visually checking the color of the bars turned on, the user can easily know the type of heating function. Similarly, when sequential cooking (cooking by a plurality of modes) is performed, the elapsed time of the total cooking time can be recognized by visually checking the number of bars turned on among the bars p to i. Therefore, the cooking state can be easily checked. In addition, by checking the color of the bars turned on, the current heating function can be easily identified.

85 The present invention is not limited to the particular embodiment described above. For example, the unit 19 may comprise a liquid crystal display panel. The display elements are not limited to the linear display bars p to i. The display bars may be replaced with a circular display unit. In this case, a plurality of fan-shaped display elements are arranged adjacent to each other within the circular display unit. Various other changes and modifications may be made within the spirit and scope of the invention.

90 According to the present invention, by arranging a plurality of parallel display elements in the display unit, the number of display elements turned on is sequentially changed to indicate the elapsed time of the total cooking time. At the same time, in sequential cooking for continuous cooking by a plurality of heating functions, the ON/OFF states of the display elements are sequentially changed to indicate the elapsed time of the total cooking time of sequential cooking. The display color in the display device changes every time the heating function is changed. Therefore, the elapsed time of the total cooking time at any moment during cooking and the elapsed time of the total cooking time of sequential cooking can be immediately observed and visually checked. The type of cooking function can be easily confirmed to improve operability.

120 CLAIMS

1. A cooking apparatus comprising:
 - a heating chamber having a plurality of heating functions so as to cook food in accordance with a plurality of cooking modes;
 - cooking information setting means for setting at least one of the cooking modes and cooking information including a cooking time;
 - cooking information displaying means having a display element for performing graphic display of at least time elapsed information of

the cooking information in accordance with a plurality of colors respectively corresponding to the plurality of cooking modes;

- 5 first control means for designating a given heating function in said heating chamber in accordance with the set cooking information and controlling at least a cooking drive time required for the given heating function; and second control means for calculating the time elapsed information to drive at least said graphic display element in said cooking information display means and for designating a color for the time elapsed information in accordance with a type of cooking mode.
- 10 2. An apparatus according to claim 1, wherein one of the plurality of heating functions assigned to said heating chamber is a microwave oven range function.
- 15 3. An apparatus according to claim 1, wherein one of the plurality of heating functions assigned to said heating chamber is an oven function.
- 20 4. An apparatus according to claim 1, wherein said cooking information setting means can set each of the plurality of cooking modes independently and at least two cooking modes continuously in combination.
- 25 5. An apparatus according to claim 1, wherein said cooking information setting means comprises a keyboard and a timer dial.
- 30 6. An apparatus according to claim 1, wherein said graphic display element of said cooking information display means comprises a plurality of bar display elements with at least two different colors for performing the display.
- 35 7. An apparatus according to claim 6, wherein said bar display elements are arranged in alternate colors.
- 40 8. An apparatus according to claim 1, wherein said first control means comprises a main controller and a driving controller.
- 45 9. An apparatus according to claim 1, wherein said second control means calculates a graphic display signal representing an elapsed time of the preset cooking time as the elapsed time information when the single mode is set by said cooking information setting means.
- 50 10. An apparatus according to claim 1, wherein said second control means calculates a graphic display signal representing the elapsed time of the total cooking time when at least two cooking modes are continuously performed in combination, and changes a color every time the cooking mode changes.
- 55 11. An apparatus according to claim 6, wherein said second control means sequentially turns on said plurality of bar display elements corresponding to the elapsed time information of the cooking time and turns off all of said plurality of bar display elements when the cooking time has elapsed.
- 60 12. An apparatus according to claim 6, wherein each of said plurality of bar display

elements comprises one of a fluorescent lamp or a light-emitting diode.

13. An apparatus according to claim 1, wherein said graphic display element of said cooking information display means comprises a first display element corresponding to the microwave oven range and a second display element commonly corresponding to the oven and grill functions.
- 70 14. An apparatus according to claim 6, wherein said plurality of bar display elements indicate the elapsed time information in units of 1/4 of the total cooking time.
- 75 15. An apparatus according to claim 10, wherein said second control means causes said plurality of bar display elements to display in a first color the elapsed time in a first cooking mode, causes said plurality of bar display elements to turn off when the cooking time of the first cooking mode has elapsed, and causes said plurality of bar display elements to display in a second color the elapsed time in a second cooking mode of the total cooking time.
- 80 16. An apparatus according to claim 1, wherein said second control means comprises a main controller and a display controller.
- 85 17. A cooking apparatus, substantially as hereinbefore described with reference to the accompanying drawings.
- 90 95

Printed in the United Kingdom for Her Majesty's Stationery Office, Dd 8818935, 1985, 4235. Published at The Patent Office, 25 Southampton Buildings, London, WC2A 1AY, from which copies may be obtained.