

Allen & Wells,
Steam-Engine Valve-Gear.
N^o 9,792. Patented June 21, 1852.

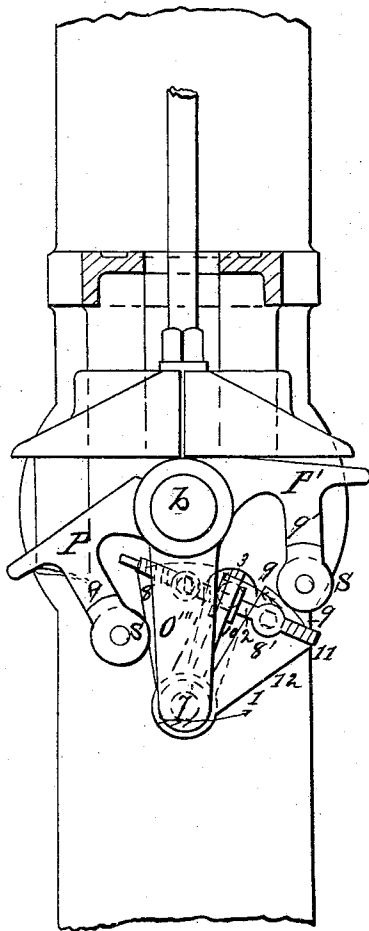

UNITED STATES PATENT OFFICE.

HORATIO ALLEN AND D. G. WELLS, OF NEW YORK, N. Y.

CUT-OFF FOR STEAM-ENGINES.

Specification of Letters Patent No. 9,792, dated June 21, 1853.

To all whom it may concern:

Be it known that we, HORATIO ALLEN and D. G. WELLS, of the city, county, and State of New York, have invented a new and useful Improvement in Expansion-Gears or Cut-Offs of Steam-Engines; and we hereby declare that the following is a full, clear, and exact description of the construction and operation of the same, reference being had to the annexed drawings, making part of the specification.

Our improvements in valve gearing have resulted from our efforts to simplify the arrangement of cut off valve patented by Horatio Allen, one of the parties to the present specification, 6th Feb., 1849. In that arrangement the toes called in that patent secondary or loose toes to raise or lower the steam valves, required several shafts to carry them. We have been enabled to effect the desired simplicity by placing the rock shaft which carries the exhaust valve toes in the same plane with the valve stems, about midway between the upper and lower steam chests. To this rock shaft so placed, the exhaust valve toes are permanently attached and on this shaft are placed the loose toes, or secondary toes, by means of which the steam valves are operated. Motion is given to raise the loose toes by means of an arm permanently attached to the rock shaft, and to lower them by means of an arm having its center on an arm attached to the rock shaft, and deriving its motion from any part of the engine whose motion commences with or slightly precedes the motion of the piston rod.

b is the rock shaft placed in same plane as the plane of the steam and exhaust valve stems.

P, P' , are loose toes supported by the rock shaft.

O''' is an arm permanently attached to the rock shaft.

10 is an arm supported by a pin 7 fastened in the end of the arm O''' .

8, 8' are two sectors supported by the same pin 7 but free to turn on it. These sectors are connected with the arm 10 by means of the right and left hand screw, 2.

9, 9' are pieces permanently attached to the loose toes P, P' , carrying the rollers 5, 5'.

The adjustment of parts is such that at the beginning of the stroke the motion of the arm O''' is in the direction indicated by the arrow 1 and the roller, 5', rests on the circular surface 9, 9, of the sector 8'.

To the arm 10 is given a motion nearly coincident with the motion of the piston.

The parts being supposed in motion as represented, that is, the rock shaft, in direction indicated by arrow 1 and the arm 10, in direction indicated by arrow 3, it will be seen that the toe P' will be raised as long as the roller 5', rests on the circular surface 9, 9, and that as soon as the corner 11 passes the roller, the toe P , will begin to descend and be lowered down by the further motion of the sector, and the passage down of the roller 5' along the surface 12.

By turning the screw 2, the sectors will be forced apart or drawn together and thus the point at which the loose toes will be lowered and the valve returned to its seat be changed. This forms the adjustable feature of the arrangement.

What we claim, is—

The mode of operating the loose toes by means of sectors combined with the rock shaft and operated in the manner substantially as herein described.

HORATIO ALLEN.
D. G. WELLS.

Witnesses:

WM. B. ALLEN,
J. W. STRATTON.