

A. GRILL.
 CONTINUOUS ACTING CENTRIFUGAL MACHINE.
 APPLICATION FILED JAN. 28, 1910.

1,002,677.

Patented Sept. 5, 1911.

3 SHEETS—SHEET 1.

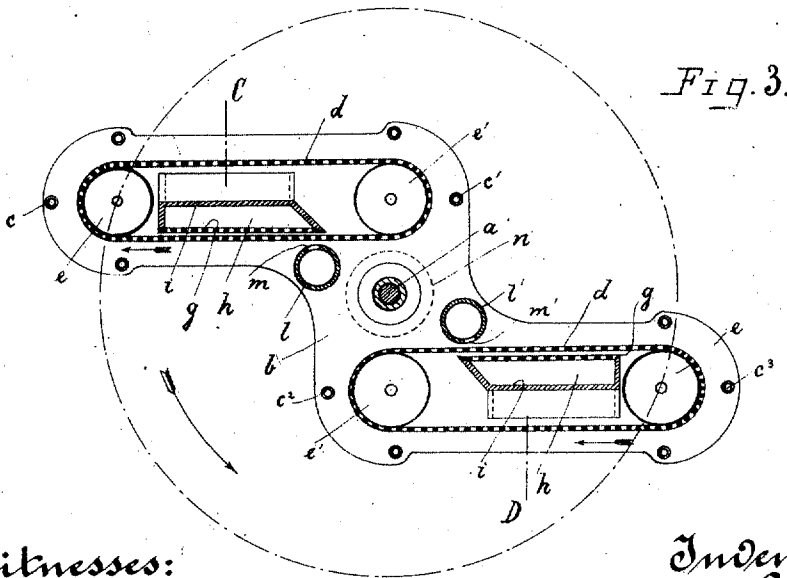
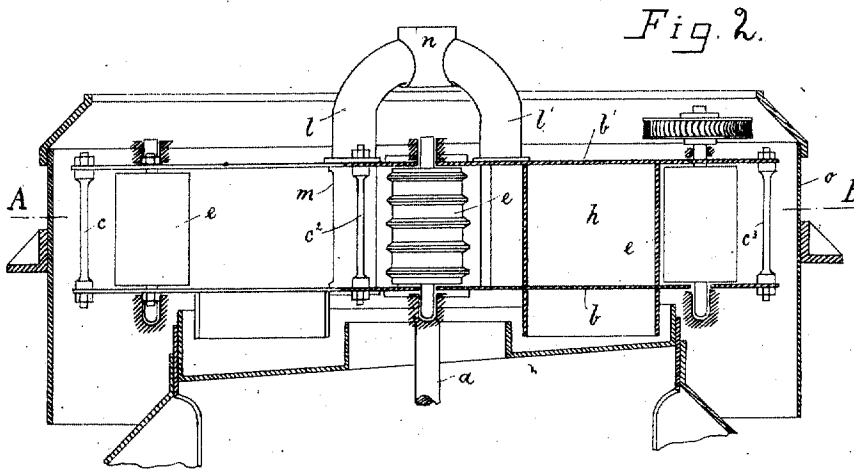
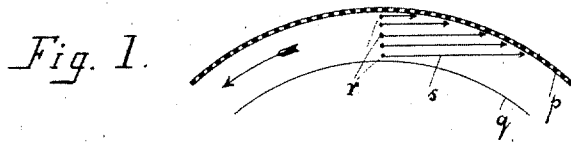

Witnesses:

Chas. A. Becker,
 George G. Anderson.

Indenter:

Anthony Grill,
 By Hugh N. Wagner,
 His Attorney.

A. GRILL.
 CONTINUOUS ACTING CENTRIFUGAL MACHINE.
 APPLICATION FILED JAN. 28, 1910.

1,002,677.

Patented Sept. 5, 1911.

3 SHEETS—SHEET 2.

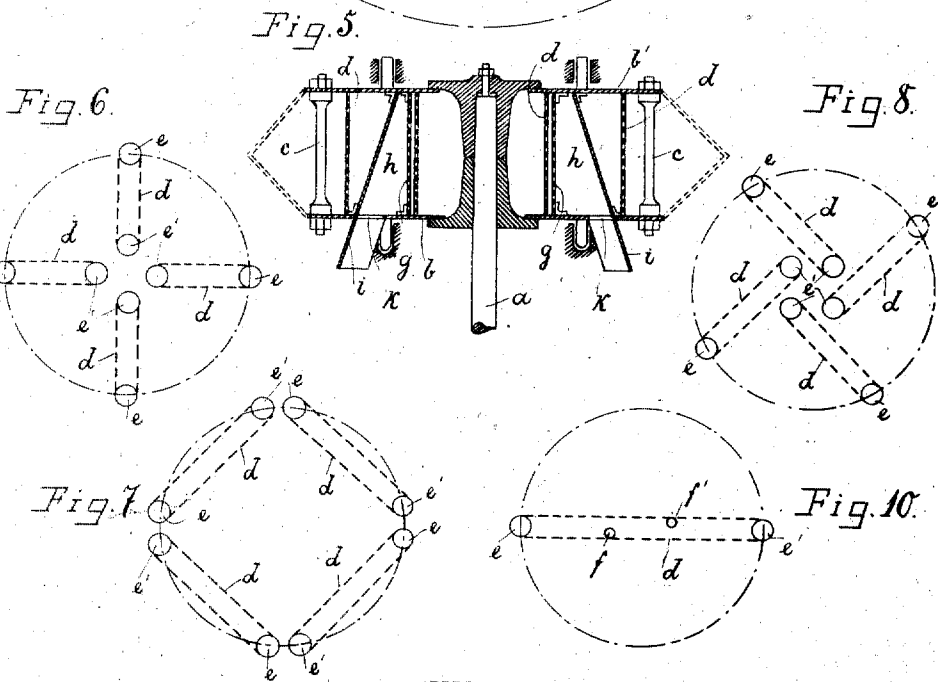
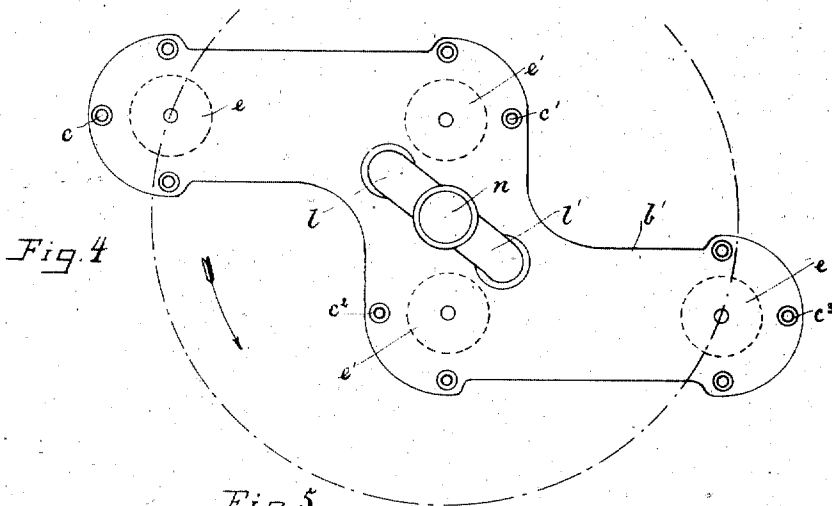

Witnesses:

Chas. A. Becker,

George G. Anderson.

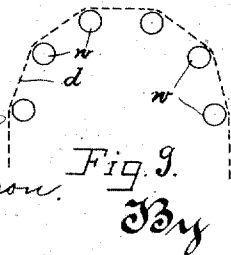

Inventor:
 Anthony Grill,

Hugh N. Wagner,
 His Attorney.

A. GRILL.
 CONTINUOUS ACTING CENTRIFUGAL MACHINE.
 APPLICATION FILED JAN. 28, 1910.

1,002,677

Patented Sept. 5, 1911.
 3 SHEETS—SHEET 2.

Fig. 11.



Fig. 12.



Fig. 11a.

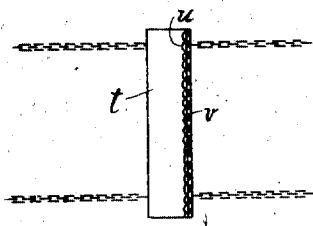

Fig. 12a.

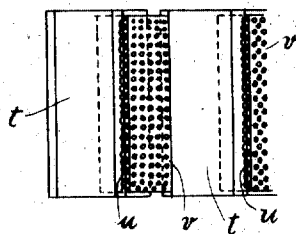

Fig. 14.

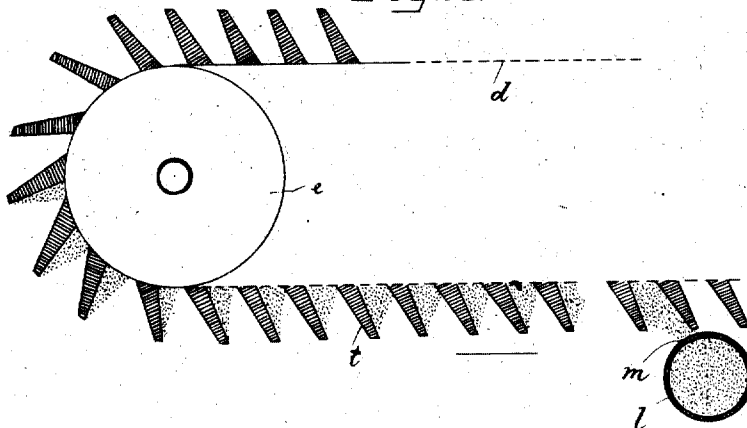

Fig. 13.



Witnesses:

Chas. A. Becker,

George G. Anderson,

Inventor:

Anthony Grill,

Hugh N. Wagner,
 His Attorney.

UNITED STATES PATENT OFFICE.

ANTHONY GRILL, OF JORDBERGA, SWEDEN.

CONTINUOUS-ACTING CENTRIFUGAL MACHINE.

1,002,677.

Specification of Letters Patent. Patented Sept. 5, 1911.

Application filed January 28, 1910. Serial No. 540,552.

To all whom it may concern:

Be it known that I, ANTHONY GRILL, director, citizen of Sweden, residing at Jordberga, in the Province of Skåne and Kingdom of Sweden, have invented certain new and useful Improvements in Continuous-Acting Centrifugal Machines, of which the following is a specification, reference being had therein to the accompanying drawings.

My invention relates to a continuous acting centrifugal machine and is directed to the arrangement of one or more partitions located at an angle relative to the force of centrifugal action and moved with or by the centrifuged material.

The object of my invention is to equip a centrifugal machine with one or more sieves traveling at an angle relative to the force of centrifugal action and having induction ports, for the material to be operated upon, opening in a plane coincident with the force of centrifugal action and therefore at an angle to the path of travel of the sieves whereby the discharge of the material upon the sieves, caused by centrifugal action, operates the said sieves and thereby produces the desired results.

Another object of my invention is to provide a centrifugal machine with an endless sieve adapted to be driven by the centrifugal action of the material operated upon and having cross bars to receive such material and thereby greatly facilitate the operation of the sieves.

A further object of my invention is the provision of a centrifugal machine in which the travel of the sieves, relative to the induction port, permits the syrup, upon its separation from the crystal of material being operated upon, to move freely in its natural direction and to pass without additional expenditure of energy, which is a great advantage over centrifugal machines heretofore constructed.

My new centrifugal machine differs from continuous acting centrifugal machines known heretofore, *e. g.*, from those having conical drums, in that the centrifuged material is not required to slide along a perforated surface, so that the expenditure of energy requisite for overcoming friction between the material and the perforated surface, which generally becomes very rough, is

saved. Owing to the individual perforated parts intermittently bending in consequence of the peculiar arrangement of the sifters or sieves, these are, in addition, cleaned automatically, and consequently very large quantities of material can be treated with relatively small expenditure of energy.

Some illustrative embodiments of my invention are represented by way of example in the accompanying drawings, wherein:—

Figure 1 is a section showing diagrammatically part of a centrifugal machine, of well-known kind; Fig. 2 is a central vertical section through one form of my improved centrifugal machine comprising the charging device; Fig. 3 is a horizontal section in the plane A—B in Fig. 2; Fig. 4 is a top plan view of the machine, parts being omitted; Fig. 5 is a vertical section on the bent line C—D in Fig. 3; Figs. 6, 7, 8, 9, and 10 are diagrammatic top plan views showing examples of different arrangements of sifters or sieves and rollers; Figs. 11 and 11^a are horizontal section and side elevation, respectively, showing various kinds of cross-members on the sifters, and Figs. 12 and 12^a are like views, respectively, showing another form of cross-member, whereas Fig. 13 shows in elevation one form of the slot in the pipe for supplying material to be centrifuged, and Fig. 14 is a diagram illustrating how the material settles on the cross-members.

Referring to the drawing, on shaft *a* is secured a frame comprising two plates *b*, *b'*, and vertical bolts *c*, *c'*, *c''*, *c'''*. Between said plates *b*, *b'* I arrange one or more partitions *d* guided like endless belts around two rollers *e*, *e'* which are journaled in said frame. Each partition may either be formed as an endless sifter or sieve with or without cross-pieces, or cross-pieces may be placed in rows like the links of a chain so that the partition consists only of such cross-pieces. Idlers *f*, *f'*, (Fig. 10) serve for preventing the sieve *d* from being bent or ruptured. The sieve may consist of metal or textile fabric and be strengthened by chains, *e. g.* Gall's chain. In the latter instance the rollers *e* and *e'* would be provided with claws or catches as indicated on the central one in Fig. 2. Rearward of the endless sieve *d* I may provide in receiving chambers *h* having slanting rear walls *i* and dis-

charge orifices k , two sieves g immovable relatively to the frame. These sieves g may be omitted if desired.

Charging pipes or tubes l, l' having longitudinal slots m, m' opening toward sieve d and corresponding thereto in breadth are built into the frame and open above into a common charging pipe n located centrally relatively to shaft a . The stationary casing o forms an envelop-chamber for collecting the centrifugal material.

My apparatus has a peculiar action, which will now be described, in comparison with well-known centrifugal machines for separating crystals from green sugar. Obviously my new centrifugal machine can be employed equally well for separating other optional substances.

In the well-known form of centrifugal machine represented in Fig. 1, p designates the reticulated cylinder and the circle q the inside boundary of the layer of sugar. The points r indicate sugar crystals having syrup adhering thereto. The cylinder rotates counter-clockwise as indicated by the arrow. If the points r be considered as secured to threads rotating around the center of the machine and the threads be supposed to be cut suddenly, it is clear that the crystals tend to fly rectilinearly tangentially to their direction of motion. Instead of the thread which compels the crystals to move in circles there is the adhesion between the crystals and the syrup. When the drop of syrup is released from its crystal corresponding to the thread being cut, the former endeavors to fly tangentially. As its velocity relatively to the peripheral velocity of the cylinder gradually diminishes, it will endeavor to escape in the direction of the arrows s through the reticulated cylinder. In this direction, however, the drop would have to pass through such a thick layer of sugar that it cannot take its natural path and must be compelled by further expenditure of energy to escape radially or approximately radially. Owing to the layer of sugar being very thick here also, the layers of sugar nearest the perforated cylinder are constantly moistened by the penetrating syrup, and this does not cease before the layers of sugar nearest the center of rotation are entirely liberated from the syrup. Consequently the time of operation is very much increased.

By means of the arrangement according to my invention the drop of syrup is able to move freely in its natural direction after being liberated from a crystal and to pass without additional expenditure of energy at right angles or approximately at right angles to the thinnest layer of sugar through the same. I attain this end by arranging the sifter or sieve at an angle to the force of centrifugal action in such manner that

the drop is not forced to pass tangentially through any thicker layer than radially. In this manner the time requisite for the penetration of the syrup is very considerably shortened.

My apparatus works as follows: The frame $b b'$ is rotated by shaft a . When the prescribed speed is attained, the material is introduced into the central pipe n and forced by centrifugal action into the branch pipes $l l'$. Only after the branches $l l'$ are filled does the material to be acted upon issue from the slits $m m'$, which may be widened toward their lower ends, if preferred, as shown in Fig. 13, and impinge on the endless sieve or reticulated partitions $d d'$ on which it is either distributed uniformly or collects at the crosspieces t , as indicated in Fig. 14. Having reached the sieve d , for example, rotating with the frame, the material is subjected on the one hand to centrifugal force and pressed against the crosspieces, and on the other hand it presses against the sieve. Consequently, between the sieve or cross-pieces and the outwardly-thrown material friction or pressure is produced which suffices to drive the sieve with the cross-pieces.

In order to prevent the rollers $e e'$ sliding on the sieve, I prefer, as mentioned above, to positively drive the rollers by Ga chains or the like secured within to the sieve so that substantially only the journal friction has to be overcome. The arrangement of cross-pieces is for assuring the sieve being driven by the material and for preventing the material running apart on the sieve. To this end the cross-pieces are adapted to the height of the thickness of the layer of the material.

Instead of the two partitions or sieves d having two pairs of rollers e, e' , illustrated in Figs. 2, 3, and 5 more or less partitions may be provided and arranged in the various ways shown in Figs. 6, 7, 8, and 10 or otherwise. Instead of one roller e or e' at each bend I may employ a plurality of small rollers w distributed on a semi-circle having the diameter of a roller e , as shown in Fig. 9, whereby free reticulated surface is gained. One of the plates $b b'$ will be so arranged that sieve d can be inserted and removed from above or below.

On the way from the charging place to the rollers e the liquid is forced directly through the sieves d and sieves g behind them, impinges against the slanting walls i of chambers h and passes through the discharge orifices k into a funnel or the like; or the liquid passes, in the event of the sifters comprising cross-pieces, both directly through the sieves d , and indirectly through the cross-pieces. To this end the cross-pieces may be shaped optionally. For example, Fig. 11 shows on the left a cross-

piece having a triangular solid section. The side against which the material lies is provided with wave-like depressions or recesses *u* located at an angle to sieve *d* so that the liquid liberated by centrifugal force finds in these recesses a free and unimpeded passage through sieve *d*. I prefer to arrange a fine sieve *v* over the wave-shaped recesses in the cross-pieces. In the central portion of Fig. 11 is shown a hollow cross-piece of triangular section. The side against which the material lies is here perforated and consequently the liquid is driven into the chamber in the cross-piece, hits against its slanting wall and passes thence through sieve *d* into the collecting chamber *h*. The right-hand part of Fig. 11 shows another form, namely a cross-piece arranged slant-wise relatively to the partition *d*, in order to be able to increase the quantity of material which lies against the cross pieces.

Figs. 12 and 12^a show cross-pieces arranged close together in a row like the links of a chain. The sifter here comprises a number of individual members, *i. e.*, the cross-pieces with intermediate reticulated members. The cross-pieces may be provided below and, if desired, also above and in the center with projecting ribs so that the material being centrifuged does not flow along the cross-pieces and consequently cannot pass between the sifter and the bottom plate *b*. As the cross-pieces project only slightly from the partition, the ribs will not be obstructive when passing around the rollers. In general, however, these ribs may be dispensed with as the material is prevented from flowing down by the centrifugal force and by friction on the sieve and the cross-piece. The radial distance of the supply tubes *l* will be governed by this circumstance. The retained crystals of sugar at first remain on sieves *d* and the cross pieces travel outwardly with the same, and are thrown against the casing *o* from the place where the sieves bend around the rollers. The bending of the sieve automatically causes it to be cleansed, which operation may be aided, in the event of the cross-pieces being provided, by arranging scraping or brushing devices. In general, such devices will be superfluous as the crystals dry in the current of air produced on the way to the rollers.

For diminishing the resistance of the air against the outwardly-moving parts of the sifters or for avoiding eddies of air behind the inwardly-moving parts of the same, the frame *b b'* may be closed laterally, as indicated in dotted lines in Fig. 5.

Obviously, my herein-described centrifugal machine can be used for bottoming sugar, and with great advantage as the layer of sugar is very thin and entirely exposed.

Also, syrups can be separated according to their purity very readily and sharply, by subdividing the slanting rear wall *i* of the collecting chamber *h* and the syrup funnel into several corresponding compartments. 70

I claim:

1. In a continuous acting centrifugal machine, a sieve arranged at an angle relative to the path of centrifugal action of the machine and operated by the centrifuged material. 75

2. In a continuous acting centrifugal machine, a sieve arranged at an angle to the path of motion of the centrifuged material and adapted for longitudinal movement by and for rotation with the centrifuged material. 80

3. In a continuous acting centrifugal machine, a series of perforated vertical partitions arranged to revolve about the axis of the machine and connected together to form bands, and guiding means for said bands, said partitions being arranged at an angle relative to the path of centrifugal action of the machine for movement by and with the centrifuged material. 85

4. In a continuous acting centrifugal machine, a series of perforated vertical partitions arranged at an angle relative to the action of the machine for movement by and with the centrifuged material, each partition consisting of a plurality of juxtaposed retaining bars arranged transversely of the plane of revolution of the machine. 90

5. In a continuous acting centrifugal machine, a series of perforated vertical partitions arranged for movement by and with the centrifuged material, each partition consisting of a plurality of retaining bars located close together and transversely of the plane of revolution of the machine, said bars being connected to form an endless band. 95

6. In a continuous acting centrifugal machine, a series of perforated vertical partitions arranged for movement by and with the centrifuged material, each partition consisting of a plurality of retaining bars located close together and transversely of the plane of revolution of the machine, endless chains to which said bars are connected, and toothed rollers over which said chains run. 100

7. In a continuous acting centrifugal machine, the combination of a series of vertical partitions connected with each other to constitute an endless element arranged at an angle relative to the action of the machine and for movement by and with the centrifuged material, a revoluble frame, rollers borne by the frame, a chamber arranged within said endless element and having a discharge orifice extending through said frame, and means for continuously feeding material to be centrifuged to the face of said partitions. 105
110
115
120
125
130

8. In a continuous acting centrifugal machine, the combination of one or more vertical perforated partitions connected with each other to constitute an endless element, and arranged for movement by and with the centrifuged material, a revoluble frame, rollers borne by the frame, and a chamber within said endless element and provided with a perforated front wall, a discharge orifice extending through said frame, and a rear wall sloping toward said orifice.

9. In a continuous acting centrifugal machine, the combination of a revoluble frame, rollers journaled therein, an endless sifter movable around said rollers and arranged at an angle relative to the path of centrifugal action of the machine, and feeding means revoluble with said frame for continuously supplying material to be centrifuged to the face of said sifter facing the direction of motion of the same, said sifter having outer projecting crossmembers and inner means for engaging said rollers.

10. In a continuous acting centrifugal machine, the combination of a revoluble frame, rollers journaled therein, an endless sifter

movable around said rollers and arranged at an angle relative to the centrifugal action of the machine, and feeding means revoluble with said frame for continuously supplying material to be centrifuged to the face of said sifter at an angle to the direction of motion of the same, said feeding means comprising a supply pipe having a branch opening through a lateral slit adjacent said sifter.

11. In a continuous acting centrifugal machine, the combination, with a series of sieves arranged to travel at an angle relative to the path of centrifugal action, of feeding means opening in a plane coincident with the force of centrifugal action and at an angle to the path of travel of said sieves, for causing the operation of the sieves by the discharge of the material to be treated.

In testimony whereof I affix my signature in presence of two witnesses.

ANTHONY GRILL.

Witnesses:

E. HEDENSKOY,
A. LARSEN.