



April 20, 1937.

P. F. DENNING

2,077,517

STOPPER FOR NONREFILLABLE BOTTLES

Filed April 9, 1935

2 Sheets-Sheet 2

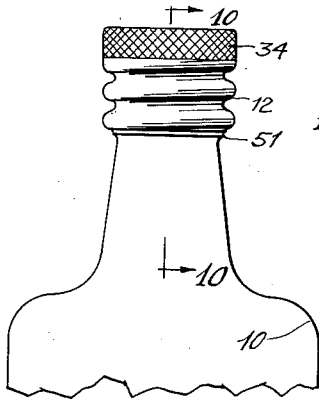

FIG. 9

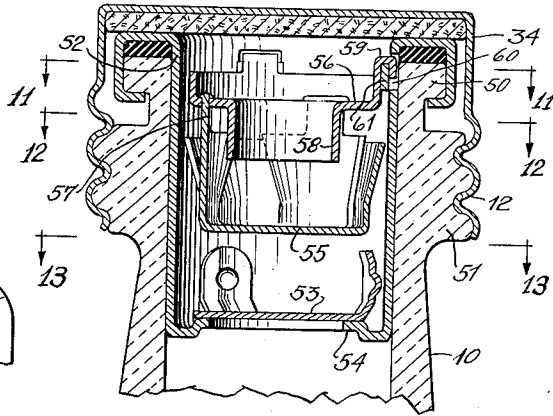

FIG. 10

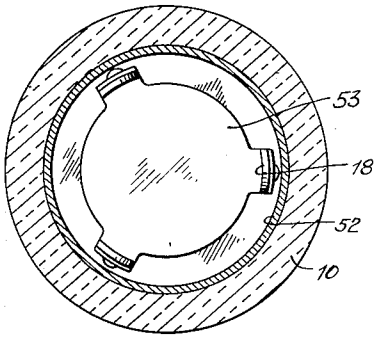

FIG. 13

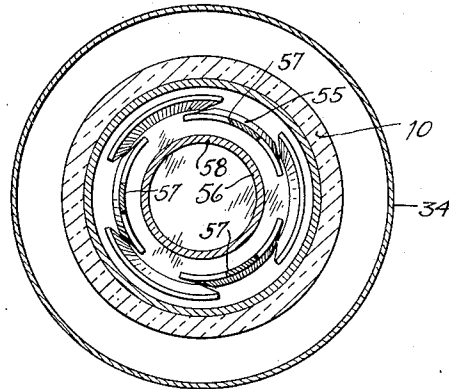

FIG. 12

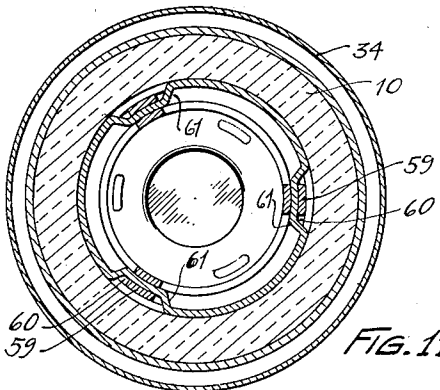

FIG. 11

INVENTOR.

BY *PATRICK F. DENNING*

*Bates, Golrick & Teare*  
ATTORNEYS

# UNITED STATES PATENT OFFICE

2,077,517

## STOPPER FOR NONREFILLABLE BOTTLES

Patrick F. Denning, Cleveland, Ohio

Application April 9, 1935, Serial No. 15,443

5 Claims. (Cl. 215—26)

This invention relates to non-refillable bottles and has for an object, the provision of a stopper which can be made entirely from metallic stampings and which is provided with a tortuous path that prevents the insertion of a tool or other foreign object into the neck of the bottle for the purpose of unseating the valve to refill the bottle.

Referring now to the drawings, Fig. 1 is a side elevation of a portion of a bottle embodying my invention; Fig. 2 is a section on an enlarged scale taken on the lines 2—2 in Fig. 1; Figs. 3, 4 and 5 are sections taken on the correspondingly numbered lines in Fig. 2; Fig. 6 is a sectional view of a portion of a bottle made in accordance with the construction shown in Fig. 2, and illustrating the pouring position; Fig. 7 is a side elevation of a portion of a bottle showing a modification of my invention; Fig. 8 is a sectional view on an enlarged scale taken on the line 8—8 in Fig. 7; Fig. 9 is a side elevation of a portion of a bottle embodying another modification; Fig. 10 is another section taken on an enlarged scale on the lines 10—10 in Fig. 9, and Figs. 11, 12 and 13, are sections taken on the correspondingly numbered lines in Fig. 10.

Referring now to the illustration in Figs. 1 to 6 inclusive, 10 designates a bottle, the neck of which has a flanged portion 11 adjacent the top thereof and a threaded portion 12 which is disposed beneath the flanged portion. The stopper construction comprises a seat 15, which is disposed on the bottom of a cup-shaped casing 16 that fits snugly against the inner wall of the bottle. Within the casing there is positioned a valve 17 that is shown as an inverted cup-shaped member that has three arms 18, which bear lightly against the inner wall of the casing and provide a guide for the valve. Normally, the valve is held against its seat by gravity, but is moved away from the seat when the bottle is tipped for pouring, as is illustrated in Fig. 6.

To provide a tortuous passageway between the valve casing 16 and the top of the bottle, I have shown a plurality of interconnected members 20 and 21 which connect the casing to a top piece 22. The member 20 is annular in shape and is provided with spaced arms 25, which extend from the inner periphery of the annulus. These arms are attached, such as by a swaging operation, to the member 21 which in turn is cup-shaped and which has spaced arms that are attached to the member 22; the attachment being made preferably by swaging the ends of arms 26 onto the member 22. The top piece

22 is provided with a skirt 30 which extends downwardly into the member 21 but which is spaced from the walls thereof and terminates short of the bottom thereof. The top piece is also provided with a laterally extending flange 31 which is spun or otherwise forced downwardly at its outer periphery and crimped, as at 32, behind the flange 11. A washer 33 is interposed between the bottle and top piece to make a fluid tight joint therebetween, while a cap 34 is threaded onto the bottle for sealing it.

When the bottle is open and tipped to a pouring position, liquid flows in the paths indicated by the arrows in Fig. 6. In such illustration, liquid flows through an opening 35 past the valve 17, into the casing 16 and thence through the opening 36 in the annular member 20, and between the arms 25 into the space that is exterior of the member 21. From such space, part of the liquid flows between the arms 26 into the cup shaped member 21 and thence through the skirt 30 and out of the bottle. Another part flows through openings 37 which are formed in the bottom of the top piece 22, although the latter openings are relatively small and are intended primarily for draining any residue that normally would be entrapped by the skirt 30. They are formed by striking upwardly a small portion of the part 22 from the bottom wall thereof, as is shown particularly in Figs. 2 and 6.

The tortuous passageway which is formed by the members 20 and 21 eliminates the possibility of unseating the valve, by means of a wire, or other tool, that may be inserted through the open end of the bottle. Furthermore, the shape of the valve 17 prevents refilling, for the weight of the liquid in the casing 16 would hold the valve onto its seat.

A modification of the invention is shown in Figs. 7 and 8, wherein the bottle is provided with a flange 40, but is not provided with any threaded portion to which the cap may be attached. Accordingly, in such case, instead of flanging the top piece laterally and downwardly, as is shown in Fig. 2, I extend it upwardly in the form of a cylinder, and provide an inturned flange 41 adjacent the top thereof. The part 22 is then anchored to the bottle by a separate piece 42, which is crimped behind the flange 40 and which is provided with a threaded part 43 that closely engages the projecting portion of the piece 22. The upper end of the part 42 may then be flanged inwardly around and crimped as at 44 behind the flange 41 for locking the two parts together. A cap 45 can be threaded

onto the portion 43 while a seal may be made between the bottle and part 42 by a washer 46. In this modification the remaining structure of the stopper is the same as that illustrated in Fig. 2.

A further modification of my invention is shown in Figs. 9 to 13 inclusive in which the bottle has a flanged 50 and threaded portion 51, respectively, similar to that shown in Fig. 2. The stopper construction is somewhat different, however, in that the top piece 52 extends downwardly in close fitting engagement with the inner wall of the bottle and provides a casing in which the valve 53 is movable. It also provides a valve seat 54. The tortuous passageway for the liquid is obtained in this modification by a plurality of interconnected members 55 and 56. The member 55 is cup-shaped and has a closed bottom together with arms 57 that are attached to the part 56; the part 56, in turn, has a skirt 58 which extends into the cup-shaped member 55 and has arms 59 which are bent outwardly and downwardly into slots 60 that are formed at spaced intervals in the wall of the top piece 52. The slots may be formed by bending portions of the wall of the port 52 inwardly, as is shown at 61, in Fig. 11. This modified construction is similar in operation to that heretofore described and may be desired by some manufacturers in preference to the other.

An important advantage of the present invention is the fact that the stopper parts may be made of sheet metal, and therefore, the entire assembly may be economically manufactured. Furthermore, the interconnected parts may be firmly attached to each other and to the bottle so as to prevent unauthorized removal thereof without breaking the glass.

I claim:—

1. A stopper for a non-refillable bottle, comprising two sections, an inturned flange on the bottom section having a valve seat with an opening therethrough, a floating valve adapted to rest on said seat, a downwardly extending skirt carried by the top section and of substantially less diameter than the top section and the bottle neck, an intermediate section comprising a tamper-proof shell, loosely surrounding said skirt and secured to the upper section, and fastening means to secure the upper section to the lower section.

2. A stopper for a non-refillable bottle, comprising two sections of approximately the same diameter, and adapted to stand in axial alignment, an inturned flange on the bottom section having a valve seat with an opening therethrough, a floating valve adapted to rest on said seat, a

downwardly extending skirt carried by the top section and of substantially less diameter than the top section, and an intermediate section comprising a tamper-proof shell loosely surrounding said skirt and secured to the upper section and adapted to limit the movement of said valve when the bottle is upturned, together with fastening means to secure the upper section to the lower section.

3. A stopper for a non-refillable bottle, comprising three sections, the upper section carrying a flange portion thereon adapted to be crimped over the upper edge of the bottle neck, and terminating in a downwardly extending skirt of reduced diameter, a lower section snugly fitting the bottle neck with an inturned flange at the bottom provided with a valve seat and an opening therethrough, a floating valve on said seat, an intermediate section comprising a tamper-proof shell loosely surrounding said skirt and secured to the upper section, and a skeleton frame securing said lower section to the said shell.

4. A stopper for a non-refillable bottle, comprising three sections, the upper section of the shell adapted to conform to the interior of the bottle neck, and an upwardly extending flange portion thereon to be crimped over the upper edge of said neck and terminating in a downwardly extending skirt of reduced diameter, drainage openings in said shell extending substantially from said skirt to the bottle wall, a lower section snugly fitting the bottle neck with an inturned flange at the bottom, provided with a valve seat and an opening therethrough, a floating valve on said seat and an intermediate section comprising a tamper-proof shell loosely surrounding said skirt and secured to the upper section, and a skeleton frame securing said lower section to said shell.

5. A stopper for a non-refillable bottle, comprising three sections, the upper section of the shell adapted to conform to the interior of the bottle neck, and an upwardly extending flange portion thereon to be crimped over the upper edge of said neck and terminating in a downwardly extending skirt of reduced diameter, a lower section snugly fitting the bottle neck with an inturned flange at the bottom, provided with a valve seat and an opening therethrough, a floating valve on said seat and an intermediate section comprising a tamper-proof shell loosely surrounding said skirt and secured to the upper section, and a skeleton frame securing said lower section to said shell.