

(19) World Intellectual Property Organization
International Bureau



(43) International Publication Date
17 September 2009 (17.09.2009)

(10) International Publication Number
WO 2009/114698 A1

- (51) International Patent Classification:
F16L 37/00 (2006.01)
- (21) International Application Number:
PCT/US2009/036970
- (22) International Filing Date:
12 March 2009 (12.03.2009)
- (25) Filing Language: English
- (26) Publication Language: English
- (30) Priority Data:
61/069,337 13 March 2008 (13.03.2008) US
12/261,539 30 October 2008 (30.10.2008) US
12/261,669 30 October 2008 (30.10.2008) US
- (71) Applicant (for all designated States except US): **PAW BIOSCIENCE** [US/US]; 28 Eaton Road, Eatontown, NJ 07724 (US).
- (72) Inventors; and
(75) Inventors/Applicants (for US only): **WILLEMSTYN, Benjamin** [US/US]; 17 Little Silver Parkway, Little Silver, NJ 07739 (US). **KORWAN, Timothy** [US/US]; 224 High Street, Reading, MA 01867 (US).
- (74) Agents: **GAGLIA, Charles, S.** et al.; Gibbons P.C., One Gateway Center, Newark, NJ 07102 (US).

(81) Designated States (unless otherwise indicated, for every kind of national protection available): AE, AG, AL, AM, AO, AT, AU, AZ, BA, BB, BG, BH, BR, BW, BY, BZ, CA, CH, CN, CO, CR, CU, CZ, DE, DK, DM, DO, DZ, EC, EE, EG, ES, FI, GB, GD, GE, GH, GM, GT, HN, HR, HU, ID, IL, IN, IS, JP, KE, KG, KM, KN, KP, KR, KZ, LA, LC, LK, LR, LS, LT, LU, LY, MA, MD, ME, MG, MK, MN, MW, MX, MY, MZ, NA, NG, NI, NO, NZ, OM, PG, PH, PL, PT, RO, RS, RU, SC, SD, SE, SG, SK, SL, SM, ST, SV, SY, TJ, TM, TN, TR, TT, TZ, UA, UG, US, UZ, VC, VN, ZA, ZM, ZW.

(84) Designated States (unless otherwise indicated, for every kind of regional protection available): ARIPO (BW, GH, GM, KE, LS, MW, MZ, NA, SD, SL, SZ, TZ, UG, ZM, ZW), Eurasian (AM, AZ, BY, KG, KZ, MD, RU, TJ, TM), European (AT, BE, BG, CH, CY, CZ, DE, DK, EE, ES, FI, FR, GB, GR, HR, HU, IE, IS, IT, LT, LU, LV, MC, MK, MT, NL, NO, PL, PT, RO, SE, SI, SK, TR), OAPI (BF, BJ, CF, CG, CI, CM, GA, GN, GQ, GW, ML, MR, NE, SN, TD, TG).

Published:

— with international search report (Art. 21(3))

(54) Title: CONNECTOR, GASKET AND METHOD OF ATTACHING THE SAME

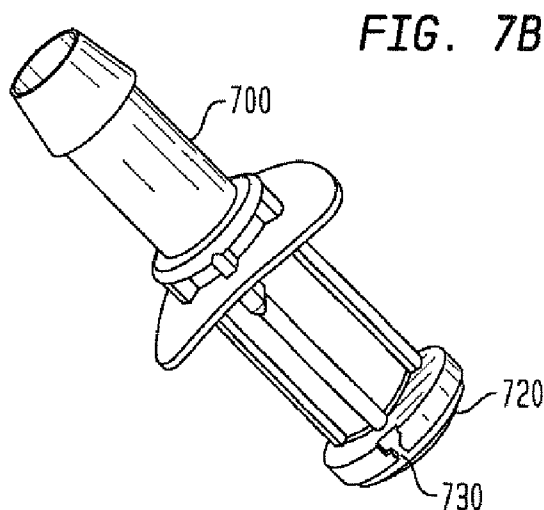

(57) Abstract: A gasket, connector assembly and method of creating a connection is described. The gasket includes a ring portion having a thickness suitable for creating a seal when compressed between two connector fitting ends, and at least one appendage pair, where each appendage of the at least one appendage pair includes an extension for engaging a reciprocally shaped receiving component on a connector fitting end to create an at least temporarily secured attachment of the gasket to the end of the connector fitting prior to creation of a seal between two connector fitting ends. The connector assembly includes a connector fitting having at least one receiving component on an end of the connector fitting and a gasket having at least one appendage, where the at least one appendage of the gasket engages the at least one receiving component to create an at least temporary secured attachment of the gasket to the connector fitting end.



WO 2009/114698 A1

CONNECTOR, GASKET AND METHOD OF ATTACHING THE SAME

Cross-Reference To Related Applications

- [1] This application claims priority of U.S. Patent Application Ser. No. 61/069,337, filed March 13, 2008, and to U.S. Patent Application Ser. No. 12/261,539, filed October 30, 2008 and 12/261,669, filed October 30, 2008, the entire disclosures of which are incorporated by reference herein as if being set forth in their entireties.

Field of the Invention

- [2] The instant invention relates to the field of mechanical connectors, and in particular to connectors for use in fluid processing machinery or other applications used in a sterilized environment.

Background of the Invention

- [3] Sanitary style flange fittings have been around for decades. For example, steel fittings are used widely in the dairy, pharmaceutical and biotechnology manufacturing industries.
- [4] These flange fittings typically have a hose barb (or nipple) on one side of the fitting for securing a fluid conduit, such as a flexible hose or tube. On the other side of the fitting, a flange to make a

hose or tube. On the other side of the fitting, a flange to make a connection with another fluid conduit or piece of equipment is usually found. Using this design, the other fluid conduit or pieces of equipment would also need to have a matching flange in order to make the proper and effective connection.

[5] However, the biotech and pharmaceutical manufacturing industry has been moving away from these steel process systems and embracing what are commonly referred to as "single-use" systems, such as those made from disposable plastic parts and rubber tubing. These "single-use" systems are extremely varied, highly customized, and built to the end-users specifications for a broad range of manufacturing applications.

[6] An example of a single-use sanitary flange fitting can be found in U.S. Patent No. 6,893,428 ("the '428 patent"), the entire disclosure of which is incorporated by reference herein as if set forth in its entirety. As described in the '428 patent, an over-wrap bag is attached to a flange formed near the middle of the connector. The over-wrap bag maintains the sterility of the enclosed end of the connector. The other end of the connector is typically attached to a piece of tubing or conduit in communication with another larger bag, which has been rendered sterile collectively with the connector. Sterile fluids pumped into the bag, either through the connector

itself, or through some other opening in the larger bag, will not be contaminated.

[7] In use, the flange fitting is intended to make a connection with another flange fitting. To make the connection, a flat rubber gasket is placed between the face of the fittings. The gasket is designed to seat into the contours of the fitting face. The flange faces are pushed together (with the gasket in between) and a circular clamp is positioned around the circumference of flanges. The clamp has a swing-bolt that, once secured in place, permits the installer to tighten the two flange faces together and compress the gasket. Once connected, the two fittings form a fluid conduit relatively free from dead-spots and capable of handling substantially high pressures.

[8] However, a drawback to these sterile flange fittings involves the installation of the gasket during connection. For example, the operator making the connection must hold the gasket in place, while at the same time align the flange faces and install the clamp around the fittings and gasket. This is a clumsy, cumbersome process at best and highly prone to contamination. Therefore, a need exists for a device, mechanism and method for readily attaching the gasket portion to the fittings of a connector while maintaining a sterile environment.

Summary of the Invention

- [9] A gasket for attachment to the face of a connector fitting is described. The gasket includes a ring portion having a thickness suitable for creating a seal when compressed between two connector fitting ends, and at least one appendage pair, where each appendage of the at least one appendage pair includes an extension for engaging a reciprocally shaped receiving component on a connector fitting end to create an at least temporarily secured attachment of the gasket to the end of the connector fitting prior to creation of a seal between two connector fitting ends.
- [10] A connector assembly is also described. The connector assembly includes a connector fitting having at least one receiving component on an end of the connector fitting and a gasket having at least one appendage, where the at least one appendage of the gasket engages the at least one receiving component to create an at least temporary secured attachment of the gasket to the connector fitting end.
- [11] A method of creating a connection between two connector fittings is also described. The method includes the steps of engaging some or all of the appendages of a gasket with a reciprocally shaped receiving component of the connector fitting, such that the gasket is at least temporarily secured to the end of the connector fitting, sterilizing the gasket and connector fitting, placing the end of a second connector fitting adjacent to the gasket attached to the

first connector fitting, such that the gasket is between the ends of the two connector fittings, and clamping the two connector fitting ends and gasket such that the gasket is compressed to form a seal and thereby create a connection between the two connector fittings.

Brief Description of the Figures

- [12] Understanding of the present invention will be facilitated by consideration of the following detailed description of the embodiments of the present invention taken in conjunction with the accompanying drawings, in which like numerals refer to like parts and in which:
- [13] FIG. 1 is a cross sectional view of an exemplary connector, according to an aspect of the present invention;
- [14] FIG. 2A is a front view of an exemplary connector, according to an aspect of the present invention;
- [15] FIG. 2B is a front view of an exemplary connector, according to an aspect of the present invention;
- [16] FIG. 2C is a front view of an exemplary connector, according to an aspect of the present invention;
- [17] FIG. 2D is a front view of an exemplary connector, according to an aspect of the present invention;

- [18] FIG. 2E is a front view of an exemplary connector, according to an aspect of the present invention;
- [19] FIG. 2F is a front view of an exemplary connector, according to an aspect of the present invention;
- [20] FIG. 2G is a front view of an exemplary connector, according to an aspect of the present invention;
- [21] FIG. 3A is a perspective view of an exemplary gasket, according to an aspect of the present invention;
- [22] FIG. 3B is a side view of the exemplary gasket of FIG. 3A, according to an aspect of the present invention;
- [23] FIG. 3C is a front view of the exemplary gasket of FIG. 3B, turned 90°;
- [24] FIG. 4A is a perspective view of an exemplary gasket, according to an aspect of the present invention;
- [25] FIG. 4B is a side view of the exemplary gasket of FIG. 4A, according to an aspect of the present invention;
- [26] FIG. 4C is a front view of the exemplary gasket of FIG. 4B, turned 90°;
- [27] FIG. 5A is a perspective view of an exemplary gasket, according to an aspect of the present invention;

- [28] FIG. 5B is a cross sectional view of an exemplary gasket and appendage, according to an aspect of the present invention;
- [29] FIG. 5C is a side view of an exemplary gasket and appendage, according to an aspect of the present invention;
- [30] FIG. 5D is a cross sectional view of an exemplary gasket and appendage, according to an aspect of the present invention;
- [31] FIG. 6A is a perspective view of an exemplary connector, according to an aspect of the present invention;
- [32] FIG. 6B is a perspective view of the exemplary gasket of FIG 4A engaging the exemplary connector of FIG 6A, according to an aspect of the present invention;
- [33] FIG. 7A is a perspective view of an exemplary connector, according to an aspect of the present invention; and
- [34] FIG 7B is a perspective view of the exemplary gasket of FIG 5C engaging the exemplary connector of FIG 7A, according to an aspect of the present invention.

Detailed Description of the Preferred Embodiments

- [35] It is to be understood that the figures and descriptions of the present invention have been simplified to illustrate elements that are relevant for a clear understanding of the present invention,

while eliminating, for the purpose of clarity, many other elements found in typical mechanical connectors. Those of ordinary skill in the art will recognize that other elements and/or steps are desirable and/or required in implementing the present invention. However, because such elements and steps are well known in the art, and because they do not facilitate a better understanding of the present invention, a discussion of such elements and steps is not provided herein. The disclosure herein is directed to all such variations and modifications to such elements and methods known to those skilled in the art. Furthermore, the embodiments identified and illustrated herein are for exemplary purposes only, and are not meant to be exclusive or limited in their description of the present invention.

[36] The present invention may generally be described as including a pre-mounted gasket on the face or fitting of a connector. The present invention provides for an improved and greatly simplified gasket installation process with a significantly reduced chance of contamination when used in a sterilized environment. This construction and attachment mechanism eliminates the operator of the device from having to locate a clean gasket in their facility. The gaskets may be sterilized separately or along with the fitting and entire connector system, which may remove the need for physically handling and positioning the gasket for proper sealing and compression.

[37] According to an aspect of the present invention and as illustrated in Figure 1, a connector is shown having a hollow barrel 1 and connector ends formed at opposite ends of barrel 1. A flange 7 is attached to and may be formed integrally with barrel 1 at a location on barrel 1 which is intermediate to the ends. A connector end 2, which may optionally have a larger diameter, is formed on an end of barrel 1 opposite connector end 3. As shown in Figures 2A - 2G, this general connector configuration may take on many different embodiments, as the various types of tubing, other connectors, or other machinery to which the present invention may connect to can vary.

[38] According to an aspect of the present invention, the gaskets as described and illustrated herein throughout may be made of plastics, polymers, rubber, silicone, EPDM, steel, or any other material or combination of materials that may be manufactured sterile or subsequently sterilized by sterilization methods as understood by those skilled in the art.

[39] According to an aspect of the present invention, the gasket may include one or more appendages located on the circumference or outer edge of the gasket. These appendages may be designed for engaging the face of the connector fitting for attachment. The appendages may be positioned at any point on the circumference of the gasket, provided that such positioning sufficiently provides for adequate attachment of the gasket to the face of the connector

fitting. For example, the appendages and corresponding reciprocal cavities may be alternatively positioned on the inner circumference, the outer circumference, and anywhere in between.

[40] As shown in Figures 3A-3C, two appendages 310 of gasket 300 may be used, where each appendage is on the opposite side of the circumference, or approximately 180° from each other around the circumference of the connector fitting face. As shown in Figures 4A-4C, four appendages may be used, where each appendage is on an opposite side of another appendage, where each appendage is approximately 90° from each other around the circumference of the connector fitting face. In yet another example, three appendages may be used, where each appendage is equidistant from each other, or approximately 120° from each other around the circumference of the connector fitting face.

[41] As explained previously, the gasket appendages may be designed for engaging the face of the connector fitting for attachment. The appendages may include any shape or structure that promotes the attachment of the gasket to the connector fitting. By non-limiting example only and referring again to Figures 4A-4C, the appendages are shaped as matching pairs, in that appendages 410 of gasket 400 have a first length, such as of approximately 0.3 inches, for example, while appendages 420 may have a second length, such as of approximately 0.484 inches, for example. Likewise, a cavity or whole 430 may be specifically sized and

shaped for receiving a corresponding protrusion from the connector fitting to which the gasket must be attached.

[42] In another embodiment of the present invention, as shown in Figures 5A and 5B, appendage 510 of gasket 500 may include an overhanging portion 520 for engaging a groove or other reciprocal portion of the connector fitting. In yet other embodiments, such as that shown in Figure 5C, for example, appendage 510 of gasket 500 may include a "T" shaped block 530 for engaging the connector fitting. The gasket appendages may alternatively be substantially u-shaped, v-shaped, a loop shape or any other shape suitable for engaging and interlocking with the cavities or reciprocal spaces positioned in the face of the connector fitting prior to compression. Further still, as shown in Figure 5D, appendage 510 of gasket 500 may include a barbed portion 540 for engaging a reciprocal portion of the connector fitting. The gasket may also include one or more additional connecting mechanisms, such as a detent between the gasket and the connector fitting.

[43] It should be appreciated that any shape or combination of shapes of one or more of the appendages may be used, provided the construction used promotes a reliable attachment of the gasket to the face of the connector fitting. In all cases, the gasket attachment may be temporary, meaning the gasket may be removed from the connector fitting, or it may alternatively be substantially permanent, meaning the gasket cannot be removed

the connector fitting without at least a partial destruction of the gasket and/or connector fitting.

[44] Likewise, the face of the connector fitting may have one or more cavities or reciprocal spaces sized and shaped for receiving and/or interlocking with the appendages of the gasket described herein. Any sort of protrusion, such as a shelf or hanger portion may be of any shape or contour, and may extend from within the cavity or from the outer edge of the circumference of the connector fitting face, provided such extension does not ultimately interfere with a clamp for connecting the two connector ends and gasket to create a seal suitable for a fluid connection. These cavities or reciprocal spaces, including any protrusions, may serve as "key slots" for engaging, receiving and/or interlocking the corresponding gasket appendages, and therefore creating a "lock and key" mechanism for either a temporary or substantially permanent attachment of the gasket to the fitting face.

[45] For example, as shown in Figure 6A, connector fitting 600 may include a first pair of matching cavities 610, inside of which is a protrusion 620. Connector fitting 600 may also include a second pair of matching cavities 630 that are larger than cavities 610, such that cavities 630 reduce the radial distance of the outer edge of the connector fitting circumference. Likewise, cavities 630 may include their own protrusion 640. As shown in Figure 6B, gasket 650 may engage connector fitting 600 for a temporary but secure

attachment. As shown, the first gasket appendage pair 660 having a hole therein engages reciprocal connector fitting cavities 610, with protrusion 620 fitting within the hole of appendage 660. Likewise, the second gasket appendage pair 670, also having a hole therein, engages reciprocal connector fitting cavities 630, with corresponding protrusion 640 fitting within the hole of appendage 670. In another embodiment as shown in Figures 7A and 7B, connector fitting 700 may include matching "T" shaped cavities 710, for receiving corresponding "T" shaped appendages 730 of gasket 720. It should be appreciated that this connection mechanism may work for any gasket appendage and reciprocal cavity shapes as described herein and as understood by those skilled in the art.

[46] The number of such cavities or reciprocal spaces should at least be equal to the number of gasket appendages. Additional cavities or reciprocal spaces may be present, provided such spaces do not interfere with the sealing of the fittings and gasket structure when compressed.

[47] During manufacture of the fitting, the gasket appendages may be installed to the connector fitting face prior to sterilization and/or sealing of any surrounding pouch. Adhesives and/or various thermal methods, as understood by those skilled in the art, may also be used in conjunction with the attachment mechanism as described herein.

[48] The present invention also includes a method of creating a connection between two connector fittings. For example, in no particular order, the method may include the steps of engaging some or all of the appendages of a gasket with a reciprocally shaped receiving component of the connector fitting, such that the gasket is at least temporarily secured to the end of the connector fitting, sterilizing the gasket and connector fitting, placing the end of a second connector fitting adjacent to the gasket attached to the first connector fitting, such that the gasket is between the ends of the two connector fittings, and clamping the two connector fitting ends and gasket such that the gasket is compressed to form a seal and thereby create a connection between the two connector fittings. The method may alternatively require that the gasket and first connector fitting are sterilized prior to securing the gasket to the first connector fitting, or may alternatively require that the gasket and first connector fitting are sterilized subsequent to securing the gasket to the first connector fitting.

[49] Those of ordinary skill in the art will recognize that many modifications and variations of the present invention may be implemented without departing from the spirit or scope of the invention. Thus, it is intended that the present invention cover the modification and variations of this invention provided they come within the scope of the appended claims and their equivalents.

Claims

1. A method of creating a connection between two connector fittings, comprising the steps of:
 - engaging each appendage of at least one appendage pair of a gasket with a reciprocally shaped receiving component of a first connector fitting, such that the gasket is at least temporarily secured to the end of the first connector fitting;
 - sterilizing the gasket and first connector fitting;
 - placing the end of a second connector fitting adjacent to the gasket at least temporarily secured to the first connector fitting, such that the gasket is substantially between the ends of the two connector fittings; and
 - clamping the two connector fitting ends and gasket such that the gasket is compressed to form a seal and thereby create a connection between the two connector fittings.
2. The method of claim 1, wherein the gasket and first connector fitting are sterilized prior to at least temporarily securing the gasket to the first connector fitting.
3. The method of claim 1, wherein the gasket and first connector fitting are sterilized subsequent to at least temporarily securing the gasket to the first connector fitting.

4. The method of claim 1, wherein the reciprocally shaped receiving component of the first connector fitting includes a cavity.
5. The method of claim 4, wherein the cavity includes a protrusion extending from said cavity.
6. The method of claim 5, wherein the appendage includes a hole sized to receive the protrusion extending from said cavity when said gasket is at least temporarily secured to the end of the first connector fitting.
7. The method of claim 6, wherein each pair of the at least one appendage pairs are of different sizes that correspond to at least an equal number of reciprocally shaped receiving components.
8. The method of claim 1, wherein at least one of the at least one appendage pair includes an overhanging portion.
9. The method of claim 1, wherein at least one of the at least one appendage pair is "T" - shaped.
10. The method of claim 1, wherein at least one of the at least one appendage pair includes a barbed portion.
11. A connector fitting, comprising:

a first end;

a second end;

a flange, wherein the flange is positioned on the connector fitting at a location that is intermediate the first and second ends; and

a plurality of receiving cavities proximate to the first end, wherein said plurality of receiving cavities are the reciprocal shape of a corresponding plurality of gasket appendages for creating an at least temporary attachment of the gasket to the first end of the connector fitting when the corresponding plurality of appendages engages ones of the plurality of receiving cavities of the connector fitting.

12. The connector fitting of claim 11, wherein at least one of the plurality of receiving cavities includes a protrusion extending from the at least one cavity.

13. The connector fitting of claim 12, wherein the protrusion engages a hole in at least one of the gasket appendages when the gasket appendages engage the receiving cavities of the connector fitting.

14. The connector fitting of claim 11, wherein ones of the plurality of receiving cavities are of different sizes.

15. The connector fitting of claim 14, wherein each one of the differently sized at least one receiving cavities are reciprocally matched to receive differently sized gasket appendages.

16. The connector fitting of claim 11, wherein at least one of the plurality of receiving cavities is "T" - shaped.
17. The connector fitting of claim 11, wherein the connector fitting is sterile.
18. The connector fitting of claim 17, wherein the connector fitting is sterilized with the gasket at least temporarily attached to the first end of the connector fitting.
19. The connector fitting of claim 11, wherein the first end has an inner circumference edge, and the plurality of receiving cavities is positioned proximate to the inner circumference edge.
20. The connector fitting of claim 11, wherein the first end has an outer circumference edge, and the plurality of receiving cavities is positioned proximate to the outer circumference edge.
21. A connector assembly comprising:
 - a connector fitting having at least one receiving component on an end of the connector fitting;
 - a gasket having at least one appendage;

wherein the at least one appendage of the gasket engages the at least one receiving component to at least temporary secure attachment of the gasket to the connector fitting.

22. The connector assembly of claim 21, wherein the connector assembly is sterile.

23. The connector assembly of claim 22, wherein the attached gasket and connector fitting are connected to a second connector fitting via a clamp, such that the gasket compresses between the connector fittings to form a sealed fluid connection.

24. The connector assembly of claim 21, wherein the at least one receiving component of said connector fitting includes a cavity.

25. The connector assembly of claim 24, wherein the cavity includes a protrusion extending from said cavity.

26. The connector assembly of claim 25, wherein the appendage includes a hole sized to receive the protrusion extending from said cavity when said gasket is attached to said connector fitting end.

27. The connector assembly of claim 26, wherein ones of the at least one gasket appendages are of different sizes, and ones of the at least one receiving component are of different sizes.

28. The connector assembly of claim 27, wherein each one of the differently sized at least one receiving components are reciprocally matched to receive each one of the differently sized at least one gasket appendages.

29. The connector assembly of claim 21, wherein the at least one gasket appendage includes an overhanging portion.

30. The connector assembly of claim 21, wherein the at least one gasket appendage is "T" - shaped.

31. The connector assembly of claim 21, wherein the at least one gasket appendage includes a barbed portion.

32. A gasket for attachment to the face of a connector fitting, comprising:
a ring portion suitable for creating a seal when compressed between two connector fitting ends; and
at least one appendage pair, wherein each appendage of the at least one appendage pair includes an extension for engaging a reciprocally shaped receiving component on a connector fitting end to at least temporarily secure

attachment of the gasket to the end of the connector fitting prior to creation of a seal between two connector fitting ends.

33. The gasket of claim 32, wherein the gasket is sterile.

34. The gasket of claim 32, wherein each appendage of the at least one appendage pair includes a hole sized to receive a protrusion extending from a cavity within said reciprocally shaped receiving component of said a connector fitting when said gasket is attached to said connector fitting end.

35. The gasket of claim 32, wherein each pair of the at least one appendage pairs are of different sizes that correspond to at least an equal number of reciprocally shaped receiving components.

36. The gasket of claim 32, wherein at least one of the at least one appendage pair includes an overhanging portion.

37. The gasket of claim 32, wherein at least one of the at least one appendage pair is "T" - shaped.

38. The gasket of claim 32, wherein at least one of the at least one appendage pair includes a barbed portion.

39. The gasket of claim 32, wherein at least the ring portion of said gasket is composed of silicone.

40. The gasket of claim 32, wherein the ring portion includes at least one ridge for engaging a reciprocal groove in the face of the connector fitting end to which the gasket attaches.

FIG. 1

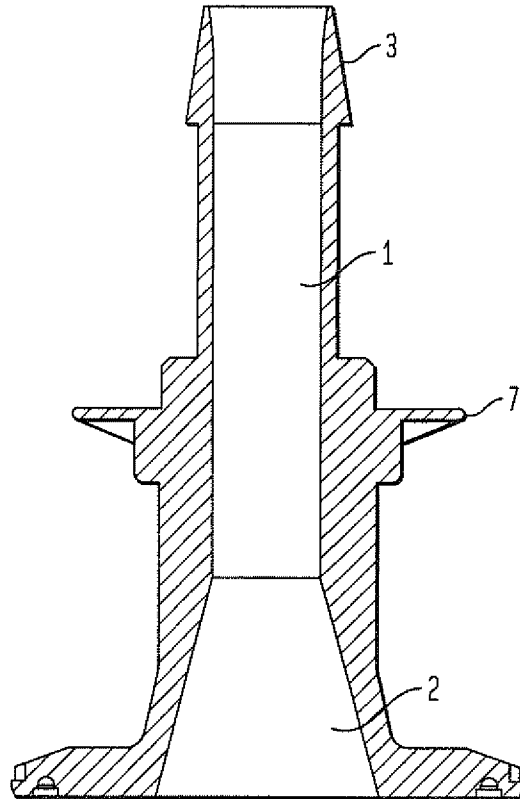

FIG. 2C

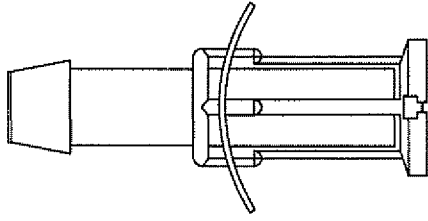

FIG. 2B

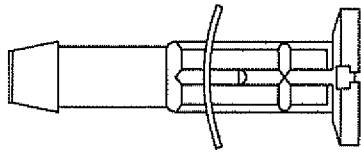

FIG. 2A

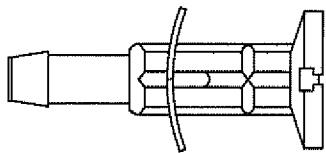

FIG. 2G

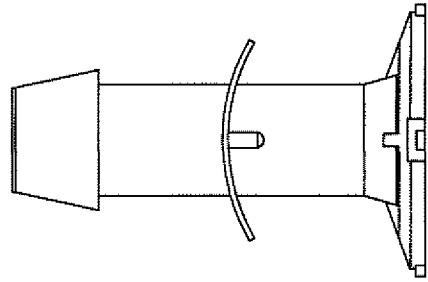

FIG. 2F

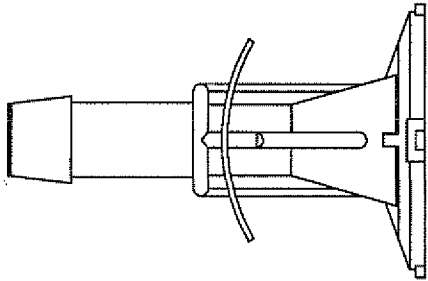

FIG. 2E

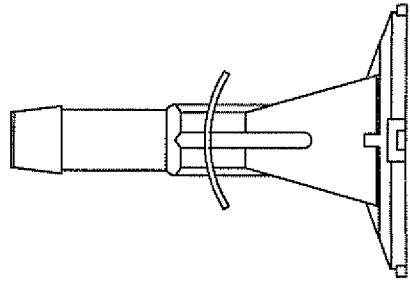

FIG. 2D

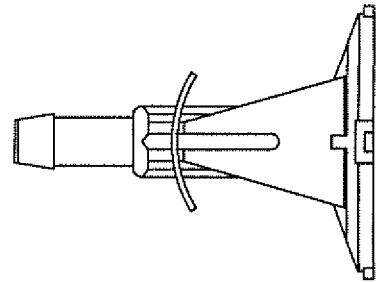

FIG. 3A

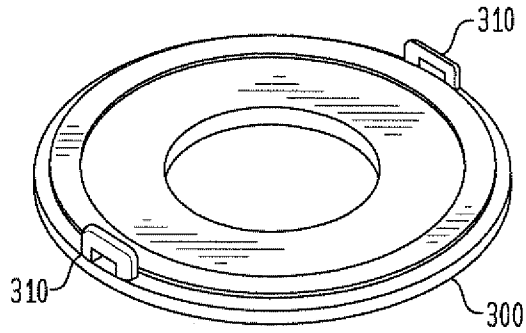

FIG. 3B

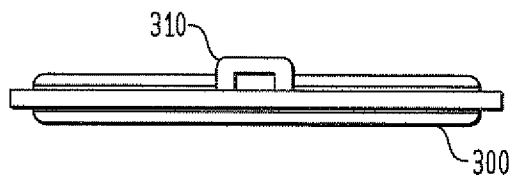
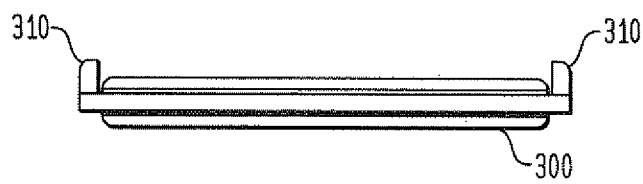

FIG. 3C



4/7

FIG. 4A

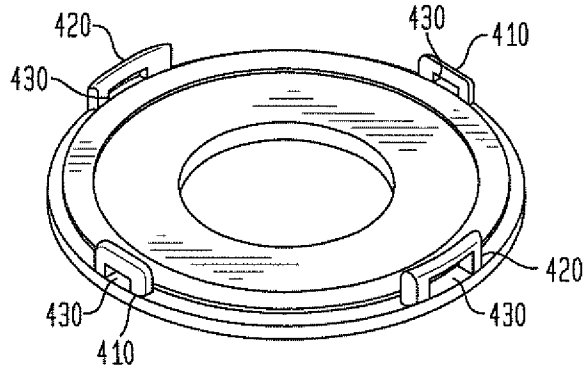

FIG. 4B

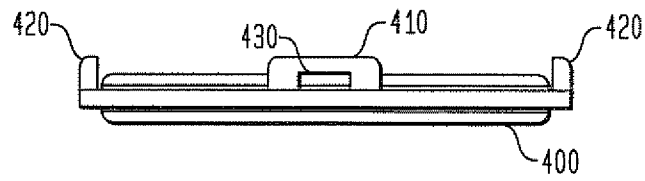
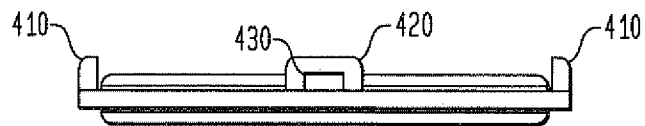

FIG. 4C



5/7

FIG. 5A

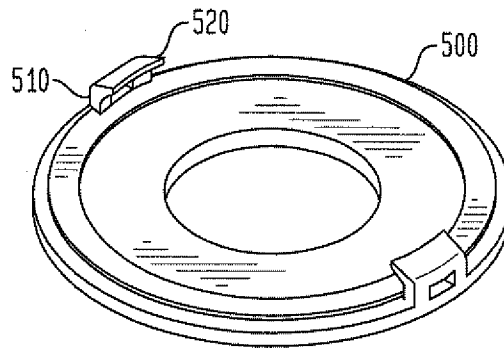

FIG. 5B

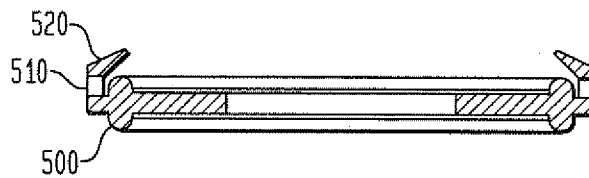

FIG. 5C

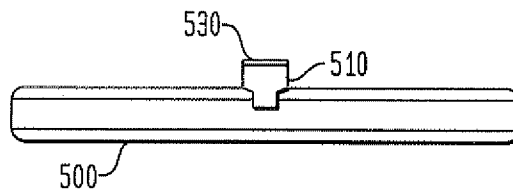
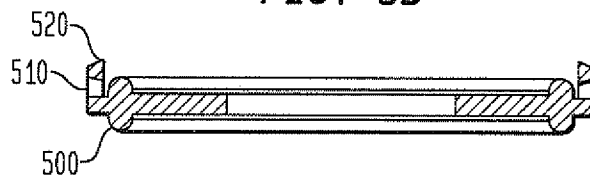

FIG. 5D



6/7

FIG. 6A

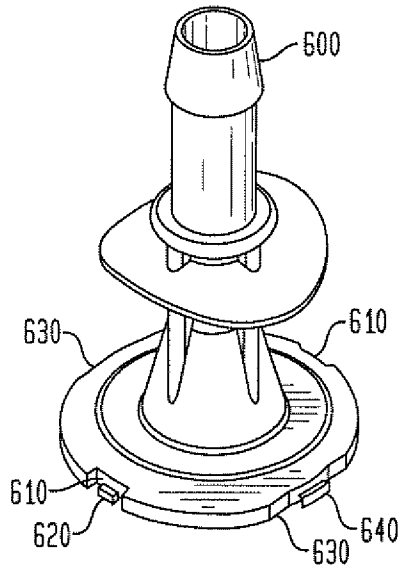
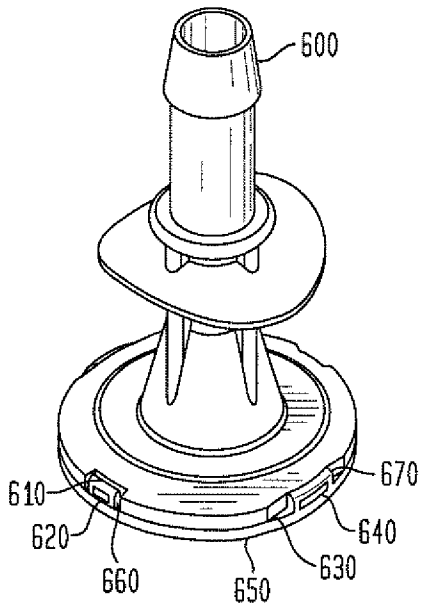

FIG. 6B



717

FIG. 7A

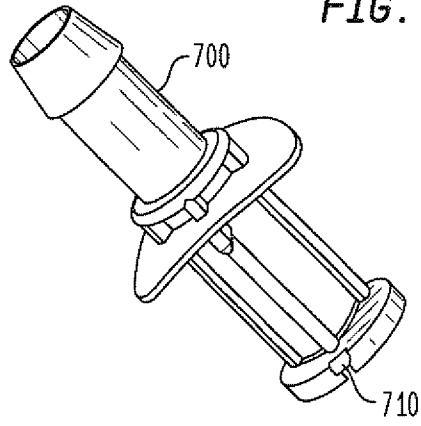
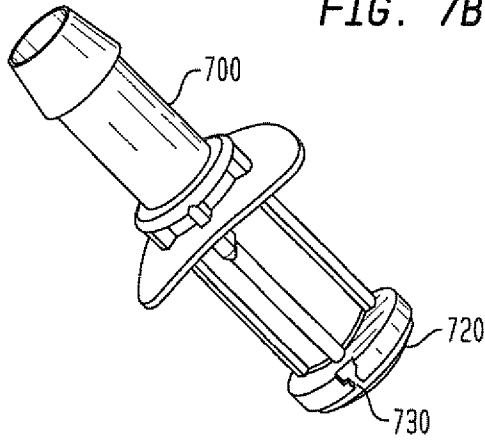

FIG. 7B



INTERNATIONAL SEARCH REPORT

International application No.

PCT/US2009/036970

A. CLASSIFICATION OF SUBJECT MATTER IPC(8) - F16L 37/00 (2009.01) USPC - 285/330 According to International Patent Classification (IPC) or to both national classification and IPC		
B. FIELDS SEARCHED		
Minimum documentation searched (classification system followed by classification symbols) IPC(8) - F16L 37/00 (2009.01) USPC - 277/136, 285/330		
Documentation searched other than minimum documentation to the extent that such documents are included in the fields searched		
Electronic data base consulted during the international search (name of data base and, where practicable, search terms used) PatBase		
C. DOCUMENTS CONSIDERED TO BE RELEVANT		
Category*	Citation of document, with indication, where appropriate, of the relevant passages	Relevant to claim No.
X	US 5,145,219 A (BABUDER) 08 September 1992 (09.09.1992) entire document	21, 24, 29-32, 35-40
---		-----
Y		1-20, 22-23, 25-28, 33-34
Y	US 3,986,508 A (BARRINGTON) 19 October 1976 (19.10.1976) entire document	1-20, 22-23, 33
Y	US 5,997,045 A (BOE et al) 07 December 1999 (07.12.1999) entire document	5-7, 12-13, 25-28, 34
<input type="checkbox"/> Further documents are listed in the continuation of Box C. <input type="checkbox"/>		
<p>* Special categories of cited documents:</p> <p>"A" document defining the general state of the art which is not considered to be of particular relevance</p> <p>"E" earlier application or patent but published on or after the international filing date</p> <p>"L" document which may throw doubts on priority claim(s) or which is cited to establish the publication date of another citation or other special reason (as specified)</p> <p>"O" document referring to an oral disclosure, use, exhibition or other means</p> <p>"P" document published prior to the international filing date but later than the priority date claimed</p> <p>"T" later document published after the international filing date or priority date and not in conflict with the application but cited to understand the principle or theory underlying the invention</p> <p>"X" document of particular relevance; the claimed invention cannot be considered novel or cannot be considered to involve an inventive step when the document is taken alone</p> <p>"Y" document of particular relevance; the claimed invention cannot be considered to involve an inventive step when the document is combined with one or more other such documents, such combination being obvious to a person skilled in the art</p> <p>"&" document member of the same patent family</p>		
Date of the actual completion of the international search 27 April 2009		Date of mailing of the international search report 05 MAY 2009
Name and mailing address of the ISA/US Mail Stop PCT, Attn: ISA/US, Commissioner for Patents P.O. Box 1450, Alexandria, Virginia 22313-1450 Facsimile No. 571-273-3201		Authorized officer: Blaine R. Copenheaver PCT Helpdesk: 571-272-4300 PCT OSP: 571-272-7774