

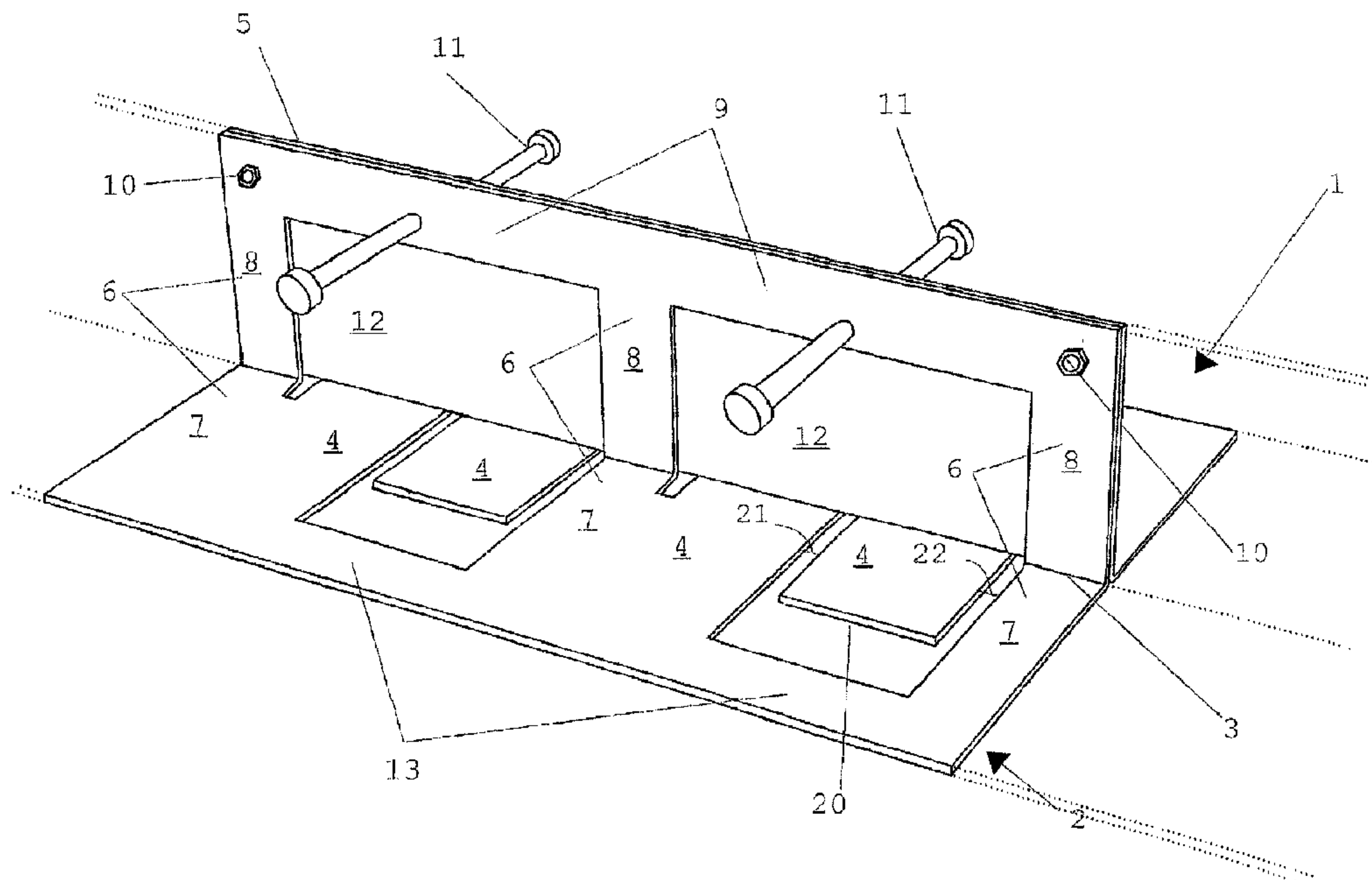

(22) Date de dépôt/Filing Date: 2003/08/20
 (41) Mise à la disp. pub./Open to Public Insp.: 2004/02/21
 (45) Date de délivrance/Issue Date: 2011/03/29
 (30) Priorité/Priority: 2002/08/21 (BEEP-2447159.1)

(51) Cl.Int./Int.Cl. *E01C 11/14* (2006.01)
 (72) Inventeur/Inventor:
 MICHIELS, PIERRE, BE
 (73) Propriétaire/Owner:
 PLAKABETON S.A., BE
 (74) Agent: GOUDREAU GAGE DUBUC

(54) Titre : DISPOSITIF DE MONTAGE DE JOINTS DE DILATATION, NOTAMMENT ENTRE DES DALLES EN BETON
 (54) Title: DEVICE FOR EQUIPPING AN EXPANSION JOINT, IN PARTICULAR AN EXPANSION JOINT BETWEEN CONCRETE SLABS



(57) **Abrégé/Abstract:**

The present invention is related to a device intended to establish a connection between two adjacent slabs, preferably concrete slabs, by equipping the expansion joint between said slabs, wherein said device is constituted by an assembly of two modules derived from sheets, each of the modules comprising: - a first series of flat elements, which form projections, - a second series of elements in the form of a right angle, which are integral with said projections, said elements in the form of a right angle comprising a first flat part, which is in the same plane as said projections, and a raised second flat part, which forms a right angle with said first part, - flat elements, which are in the same plane as said raised parts and which form connections in the form of first longitudinal members between said raised parts, the assembly being formed by assembling said two modules in such a way that the raised parts of the first and second module face each other along the two sides of a center plane and the longitudinal members of the first and second module equally face each other along the two sides of said same center plane, and that the projections of each module extend on both sides of said center plane

ABSTRACT

DEVICE FOR EQUIPPING AN EXPANSION JOINT,
IN PARTICULAR AN EXPANSION JOINT
BETWEEN CONCRETE SLABS

5

The present invention is related to a device intended to establish a connection between two adjacent slabs, preferably concrete slabs, by equipping the expansion joint
10 between said slabs, wherein said device is constituted by an assembly of two modules derived from sheets, each of the modules comprising:

- a first series of flat elements, which form projections,
- a second series of elements in the form of a right
15 angle, which are integral with said projections, said elements in the form of a right angle comprising a first flat part, which is in the same plane as said projections, and a raised second flat part, which forms a right angle with said first part,
- 20 - flat elements, which are in the same plane as said raised parts and which form connections in the form of first longitudinal members between said raised parts,

the assembly being formed by assembling said two modules in such a way that the raised parts of the first and second
25 module face each other along the two sides of a center plane and the longitudinal members of the first and second module equally face each other along the two sides of said same center plane, and that the projections of each module extend on both sides of said center plane

30

© Office Van Malderen

Bxl (ASB) - 06 August 2003

Our ref. : P.PLAK.03/US-P.PLAK.03/CA

5

**DESCRIPTION AND DRAWINGS FOR FILING IN
US AND CANADA**

10

**DEVICE FOR EQUIPPING AN EXPANSION JOINT, IN PARTICULAR AN
EXPANSION JOINT BETWEEN CONCRETE SLABS**

Background of the invention

[0001] The present invention relates to the
15 construction sector, in particular that of slabs for
industrial floors and, more particularly, concerns a device
which is used for equipping expansion joints between
adjacent slabs.

[0002] In this description, the word "joint" is used
20 exclusively to denote the zone or space between two
adjacent slabs while, in the area of construction, this
term is generally used to refer to the device itself which
occupies such a zone.

[0003] Devices for equipping expansion joints are
25 known in the area of concrete structures. The effect
desired from this type of device is to form a connection
between adjacent slabs while at the same time allowing
limited movement of one slab relative to the other in the
plane of the slabs, said movement being due essentially at
30 first to the shrinkage of concrete during setting and
subsequently, after setting, to thermal expansion and
contraction. The devices are supposed to ensure the
transfer of loads between adjacent slabs and to preserve

the planarity of the slabs as a whole while avoiding fractures and damage at the edges of the slabs.

[0004] The device is to be designed to allow quick and easy placement during the casting of the concrete
5 slabs. It should likewise ensure that the edges of the slabs have sufficient mechanical resistance to rolling stresses, i.e. stresses resulting from vehicles rolling over the slabs, and the like.

[0005] A first known solution in the prior art uses
10 sliding dowels which cross the joint and penetrate into the concrete on both sides and which can be provided with armoring reinforcements. These are rather complex systems which are difficult to place and to keep in place during the casting of the slabs. In particular, there is a
15 difficulty in keeping the dowels parallel to each other during installation on site.

The following documents are related to devices which use dowelling. Document WO0134912 is related to an expansion joint between concrete slabs, characterized in that at
20 least two dowels are retained by one runner that substantially divides adjoining concrete slabs. Document US2349983 is related to a device for dowelling transverse joints of concrete road pavements. Document US2138817 is related to a road joint equipped with a pair of spaced
25 members having alternating feet sections, and dowels penetrating the road joint.

[0006] Another device uses load transfer plates, which are placed underneath the joint in such a way as to extend from one edge of said joint to the other and which
30 are provided with anchoring elements. One disadvantage is that it is difficult to align individual plates along a rectilinear joint. Moreover, this type of device does not provide any reinforcement of the upper part of the joint, referred to as "lips of the joint" in the technical jargon.

Objects of the invention

5 [0007] The present invention aims to provide a device which enables an expansion joint between two slabs to be equipped and offers a solution to existing problems with the prior-art devices.

10 Summary of the invention

[0008] The present invention is related to a device intended to establish a connection between two adjacent slabs, preferably concrete slabs, by equipping the expansion joint between said slabs, wherein said device is
15 constituted by an assembly of two modules derived from sheets, each of the modules comprising:

- a first series of flat elements, which form projections,
 - a second series of elements in the form of a right angle, which are integral with said projections, said
20 elements in the form of a right angle comprising a first flat part, which is in the same plane as said projections, and a raised second flat part, which forms a right angle with said first part,
 - flat elements, which are in the same plane as said
25 raised parts and which form connections in the form of first longitudinal members between said raised parts,
- the assembly being formed by assembling said two modules in such a way that the raised parts of the first and second module face each other along the two sides of a center
30 plane and the longitudinal members of the first and second module equally face each other along the two sides of said same center plane, and that the projections of each module extend on both sides of said center plane.

[0009] A device of the invention may furthermore comprise flat elements which are in the same plane as said projections and form connections in the form of second longitudinal members, each second longitudinal member being present between the ends of one of said projections and of one of said first parts, being situated in the same plane as said projections.

[0010] A device of the invention may furthermore comprise a separation element, such as a foil or sheet, between the two modules.

[0011] The modules derived from sheets may be fixed to one another by temporary fixing means. Said modules may be provided with anchoring elements.

[0012] The invention is equally related to a module intended to be used in a device of the invention, wherein said module comprises:

- a first series of flat elements, which form projections,
- a second series of elements in the form of a right angle, which are integral with said projections, said elements in the form of a right angle comprising a first flat part, which is in the same plane as said projections, and a raised second flat part, which forms a right angle with said first part,
- flat elements, which are in the same plane as said raised part and which form connections in the form of first longitudinal members between said raised parts.

[0013] A module of the invention may furthermore comprise flat elements which are in the same plane as said projections and which form connections in the form of second longitudinal members, each second longitudinal member being present between the ends of one of said projections and one of said first parts, being situated in the same plane as said projections..

Brief description of the drawings.

[0014] Figures 1 and 2 represent, by way of illustration, perspective views of two similar modules forming a device according to the present invention.

[0015] Figures 3a to 3d represent a first sheet cutting, folding and assembly pattern for achieving a first embodiment of the invention.

[0016] Figures 4a and 4b represent details of cutting patterns for achieving two different embodiments of the invention.

[0017] Figures 5a to 5d represent a second sheet cutting, folding and assembly pattern for achieving a device according to the invention.

[0018] Figure 6a-d shows a sheet cutting, folding and assembly pattern of a complete device according to the invention. Figure 6a shows the initial sheet. Figure 6b shows the sheet after a pattern has been cut out. Figure 6c shows the sheet after folding along a folding line. Figure 6d shows two folded sheet modules assembled together to form a device according to the invention.

[0019] Figure 7a-d shows another sheet cutting, folding and assembly pattern for achieving a particular embodiment of the invention. Figure 7a shows the initial sheet. Figure 7b shows the sheet after a pattern has been cut out. Figure 7c shows the sheet after folding along a folding line. Figure 7d shows two folded sheet modules assembled together to form a device according to the invention.

Detailed description of the invention

[0020] Figure 1 shows part of a device according to the invention. As indicated by dotted lines, a complete device extends in such a way that the constituent parts repeat themselves over a longer length, more particularly

5a

the length of the complete joint which is provided. The device is constituted by two similar modules (references 1 and 2), which are constructed from two sheets of metal, preferably steel. The sheets are cut according to a predetermined pattern, then folded along a line 3 in such a way as to form meshing flat parts 4 which pass from one side of the joint to the other underneath the center plane 5. For on-site placement, the center plane 5 is provided to coincide with that of the joint between the slabs. Each

module 1 or 2 derived from a cut and shaped sheet has a series of these flat plates 4, which will also be referred to as "projections" 4 of each module. Between these projections 4 of each of the two modules 1 or 2, there is a series of elements 6 in the form of a right angle, said elements 6 being integral with the projections 4 and having a part 7 in the same plane as the projections and a raised part 8. These raised parts 8 are attached to each other at their ends by a first longitudinal member 9 which is vertical when in position. The purpose of the longitudinal members 9 is to reinforce the upper part or edge of the slabs, that it is to say the part which will form the lips of the joint. In the device of the invention, the raised part 8 of one module 1 is back to back with the raised part 8 of the other module 2, and the longitudinal member 9 of one module is equally back to back with the longitudinal member 9 of the other module 2. The modules 1 and 2 are preferably secured by temporary fixing means, such as bolts 10, clips or other adequate means.

[0021] A separation sheet 12 is preferably enclosed between modules 1 and 2 so as to separate the concrete on each side of the joint. The separation sheet 12 can be made of metal or of a synthetic material, preferably a compressible synthetic material such as rigid polystyrene foam.

[0022] Anchoring elements in various forms, dowels 11 for example, are preferably attached to the longitudinal member 9 of each of the two modules 1 and 2. Such anchoring elements are not necessarily perpendicular to the part 8 and other angles may be chosen.

[0023] In the embodiment shown in Figures 1 and 2, each of the projections 4 of each module is connected to the part 7 of the adjacent projection by a flat second longitudinal member 13 which is horizontal when in

position. It will be noted that this longitudinal member 13 does not constitute an essential element. It is purely optional within the context of the invention even though it contributes to the rigidity of the assembly owing to the
5 fact that it is situated underneath the slab or is embedded in the latter.

[0024] The length of the projections 4 is preferably such that there is no direct contact between the end 20 of a projection belonging to one module 1 or 2 and the flat
10 longitudinal member 13 of the other module. In the same way, the distance 21 between two adjacent projections of the two modules 1 and 2, as well as the distance 22 between a projection 4 of one module 1 or 2 and a flat part 7 of the other module, is such that there is no direct contact
15 between the elements separated by said distances. In general, it may be stated that a projection 4 belonging to one module 1 or 2 is not in physical contact with any part of the other module in the assembly of the invention. In each embodiment of the invention, the projections 4 of the
20 device form a meshing pattern, it being possible for parts 6 in the form of a right angle to be situated between two consecutive projections.

[0025] The characteristic features of the invention are as follows: it concerns a continuous device which can
25 be installed over a significant length of the joint, thus facilitating placement and alignment. Said device is generally assembled before being put in place on site. While being continuous, said device comprises parts 4 which are underneath or embedded in concrete slabs while crossing
30 the joint. The projections 4 are situated on each side of said joint, thus ensuring the desired transfer of loads. The device furthermore comprises parts 6 in the form of a right angle, attached to each other by longitudinal members 9 situated at the two sides of the upper parts of the

joint, thus forming a reinforcement of the lips of the joint and securing the whole.

[0026] Figures 3a to 3d show an example of a cutting, folding and assembly pattern for a sheet 30 so as to form a module 1 that will form part of the device of the invention shown in Figures 1 and 2. After cutting, the sheet 30 is folded at right angles along the line 3 in such a way that the elements 4 remain in the initial plane. Figure 3c shows the result, viewed from above. The projections 4, the parts 6 in the form of a right angle, the first longitudinal members 9 in the plane at right angles, and the second longitudinal members 13 in the plane of the projections can again be seen. Figure 3d shows the assembly of two shaped and cut modules 1 and 2 of the same type to form a device according to the invention.

[0027] The detail in Figure 4a shows clearly what is referred to in the context of this description as elements 4, 6, 7, 8, 9 and 13 of the embodiment shown in Figures 1 to 3. Figure 4b shows an embodiment which is slightly different and in which the longitudinal members 9 consist of a part 9a, which extends essentially over the full height of the device, and a part 9b, which extends over a lesser height. In the assembly, the parts 9a of one of the two modules will be situated opposite parts 9b of the other module. The parts 9a of the two modules will thus essentially block the passage of the concrete from one side of the joint to the other. In this embodiment of the device of the invention, it is thus possible to omit the separation sheet 12. In certain cases, it may nevertheless be useful to add a separation sheet, a sheet of polystyrene for example, which can compensate for significant expansion of the slabs.

[0028] Figures 5a to 5d show an embodiment which is not provided with the longitudinal members 13 in the plane

of the projections 4. The principle of this embodiment is equivalent to the preceding one although it is less rigid.

[0029] Figures 6a to 6d show a preferred embodiment of a complete device of the invention. Each of the modules
5 1 or 2 is represented as having four projections 4. At their ends, the modules 1 and 2 have extensions 31 and 32 in the form of vertical parts, which make it easier to fit a second device which forms an angle with the first.

[0030] Figures 7a to 7d show yet another embodiment,
10 more particularly a specific cutting, folding and assembly pattern according to the invention. The dotted lines represent the limits of the parts bearing the reference numbers indicated. In this form of the assembled device of the invention, each projection 4 of one of the two modules
15 1,2 is situated between two parts 7 of the right angle of the other module. This device is equivalent to the devices already described. It includes two types of longitudinal member 9: the longitudinal members 9a, which extend essentially over the height of the complete device, and the
20 longitudinal members 9b, which extend over a lesser height.

[0031] In the assembly, the parts 9a of one module will be opposite parts 9b of the other module. As in the embodiment shown in Figure 4b, it is thus possible to omit the separation sheet 12, except in particular cases.

CLAIMS

1. A device intended to establish a connection between two adjacent slabs, preferably concrete
5 slabs, by equipping the expansion joint between said slabs, wherein said device is constituted by an assembly of two modules derived from sheets, each of the modules comprising:

10 a first series of flat elements, which form projections;

a second series of elements in the form of a right angle, which are integral with said projections, said elements in the form of a right angle comprising a first flat part, which is in the same plane as said projections,
15 and a raised second flat part, which forms a right angle with said first part; and

flat elements, which are in the same plane as said raised parts and which form connections in the form of first longitudinal members between said raised parts;

20 wherein said two modules are assembled adjacent to each other, in such a way that the raised parts of the first and second module face each other along the two sides of a center plane and the longitudinal members of the first and second module equally face each other along
25 the two sides of said same center plane, and that the projections of each module extend on both sides of said center plane.

2. The device as claimed in claim 1, which furthermore comprises flat elements which are in the same
30 plane as said projections and form connections in the form of second longitudinal members, each second longitudinal member being present between the ends of one of said projections and of one of said first parts, being situated in the same plane as said projections.

3. The device according to claim 1, which furthermore comprises a separation element, such as a foil or sheet, between the two modules.

4. The device according to claim 1, wherein
5 the modules derived from sheets are fixed to one another by temporary fixing means.

5. The device according to claim 1, wherein the modules are provided with anchoring elements.

6. A module intended to be used in a device
10 as described in claim 1, wherein said module comprises:

a first series of flat elements, which form projections;

a second series of elements in the form of a right angle, which are integral with said projections, said
15 elements in the form of a right angle comprising a first flat part, which is in the same plane as said projections, and a raised second flat part, which forms a right angle with said first part; and

flat elements, which are in the same plane as
20 said raised part and which form connections in the form of first longitudinal members between said raised parts.

7. The module as claimed in claim 6, which furthermore comprises flat elements which are in the same plane as said projections and which form connections in the
25 form of second longitudinal members, each second longitudinal member being present between the ends of one of said projections and one of said first parts, being situated in the same plane as said projections.

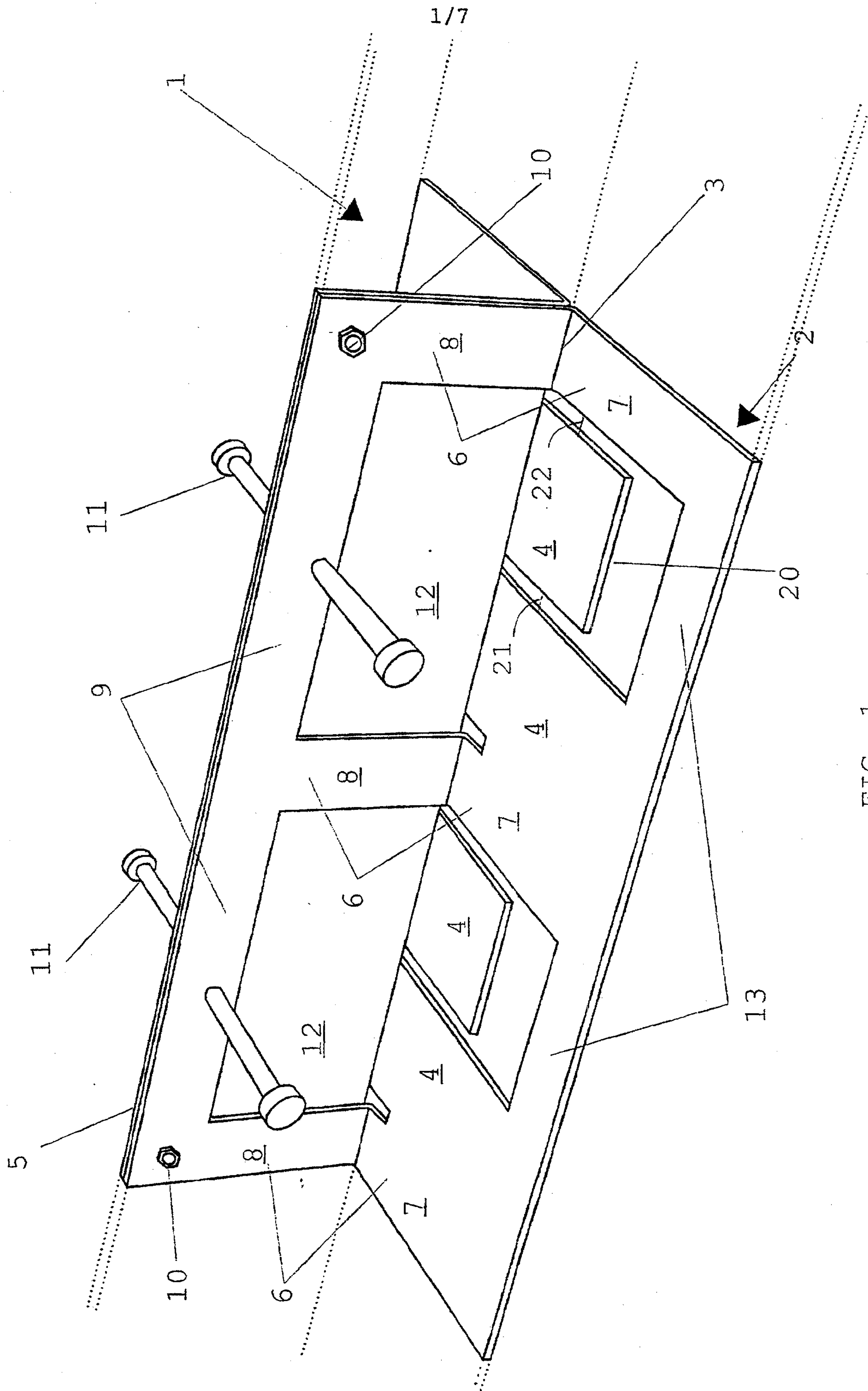

FIG. 1

2/7

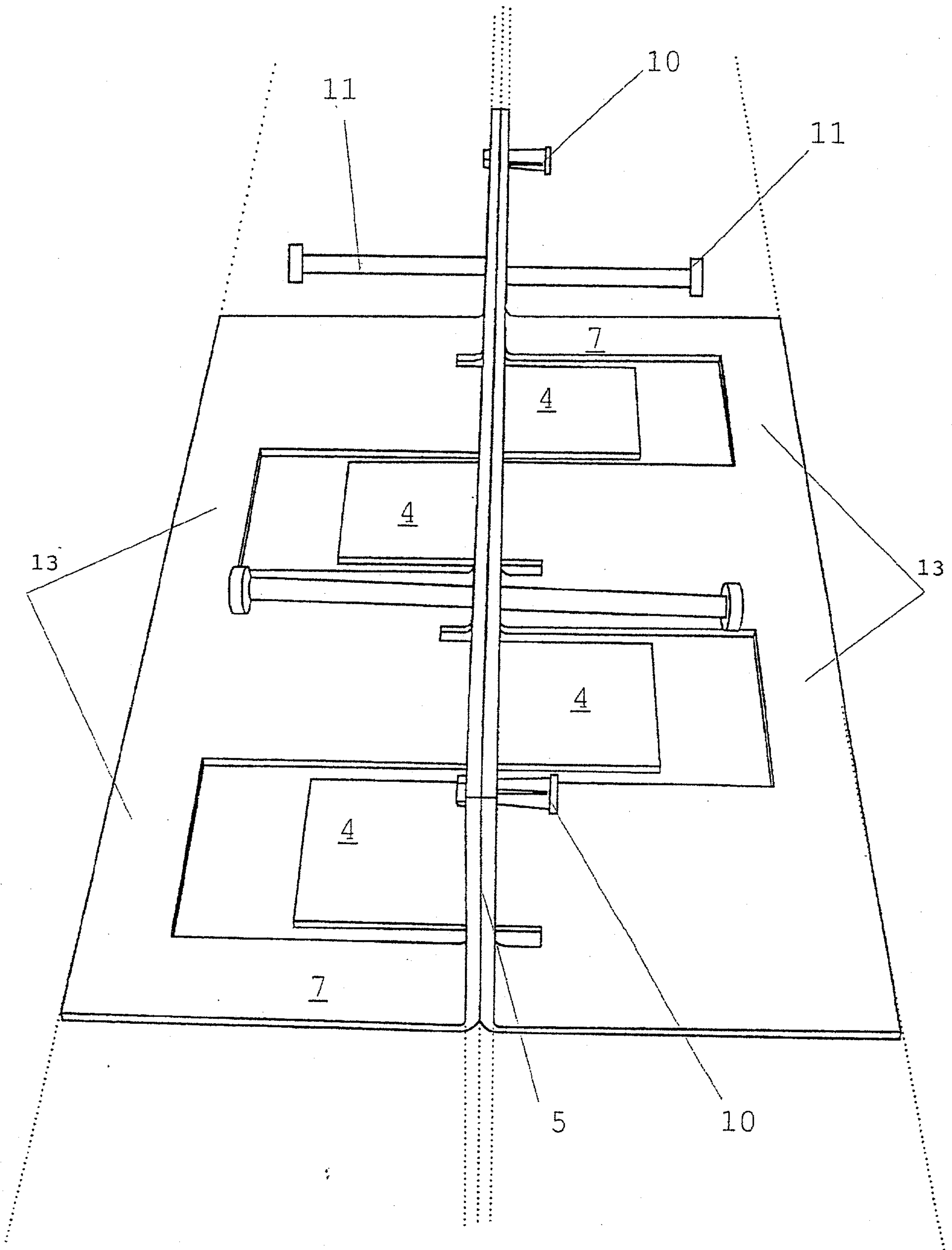

FIG. 2

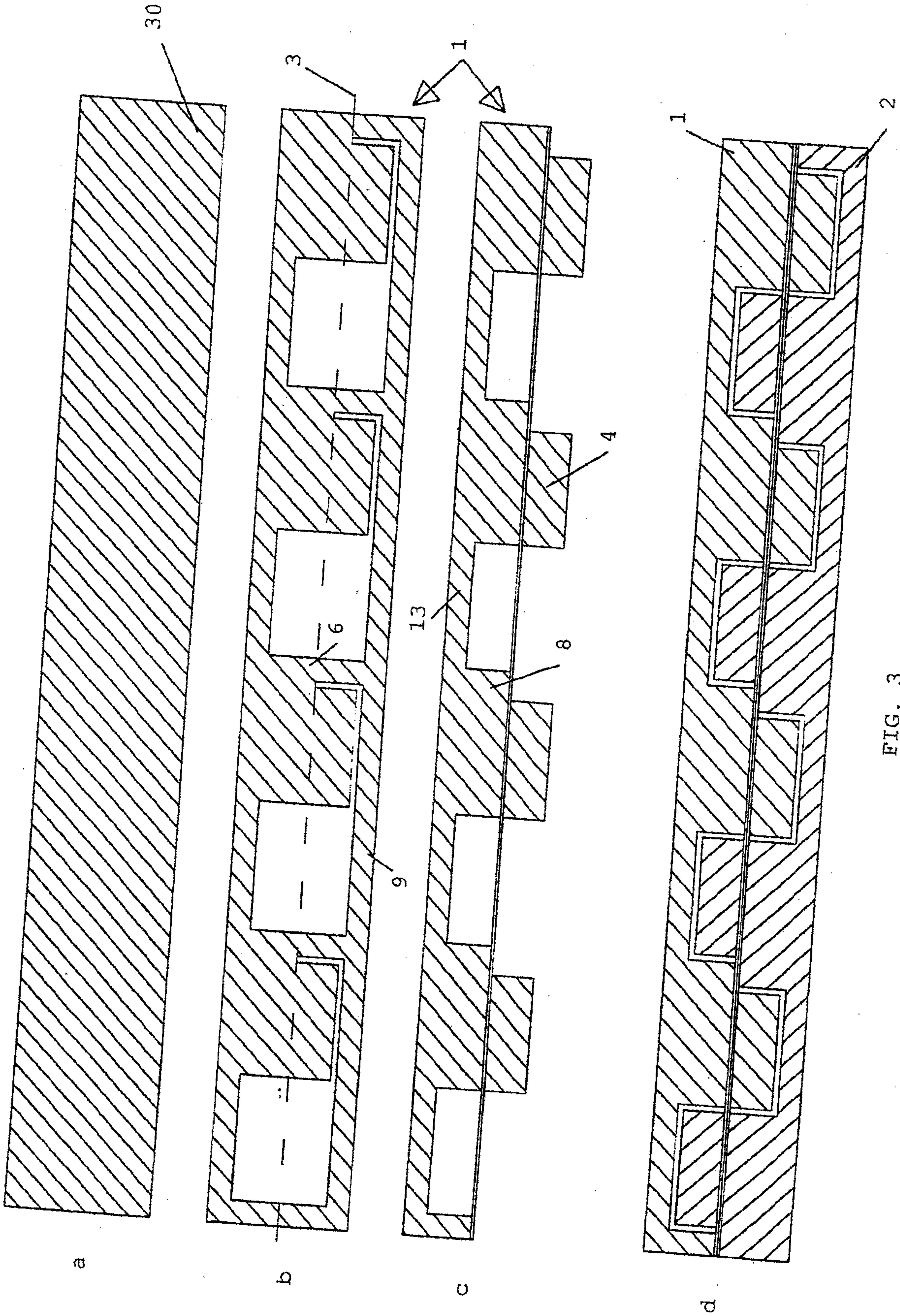

FIG. 3

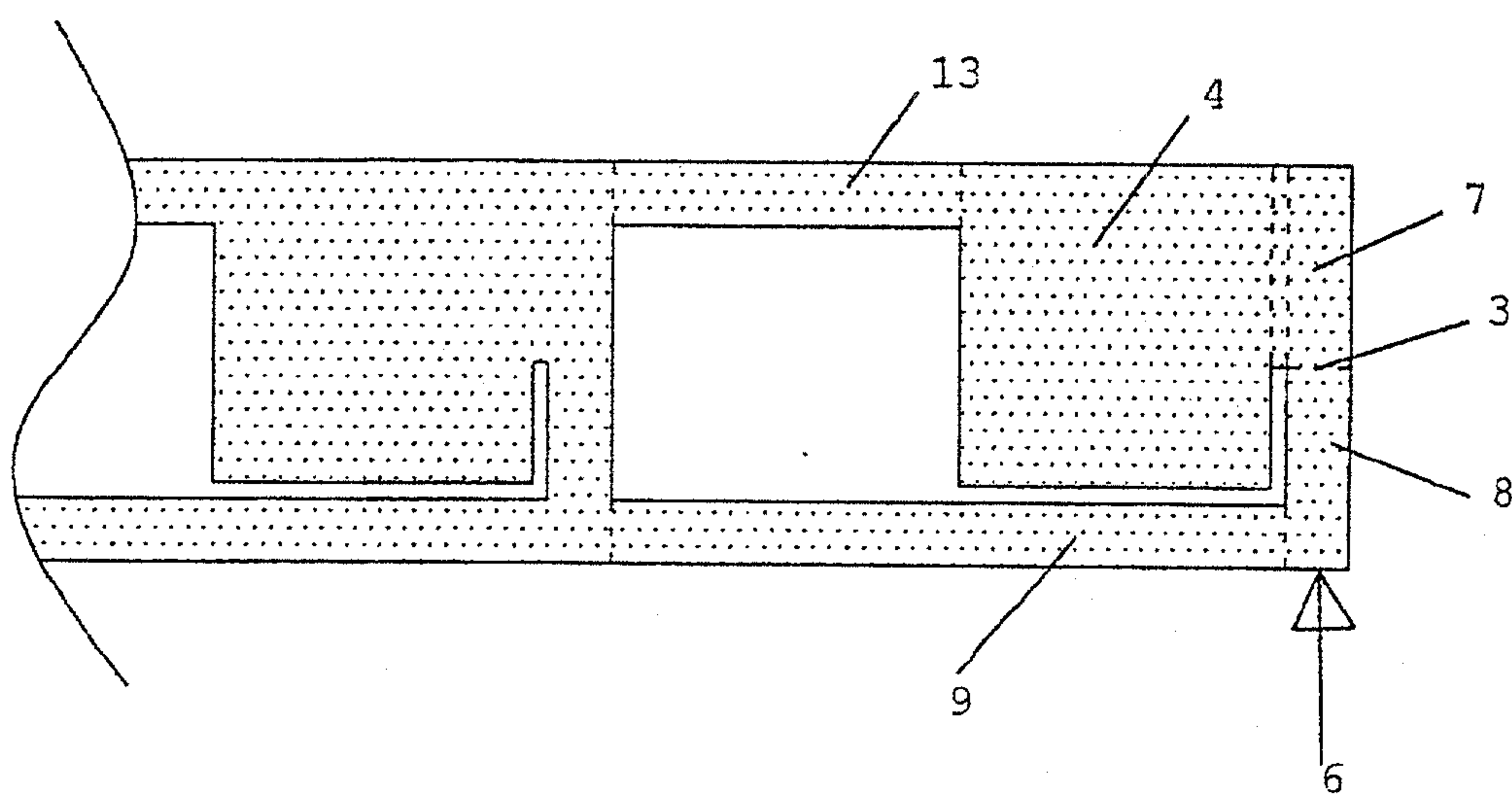

FIG. 4a

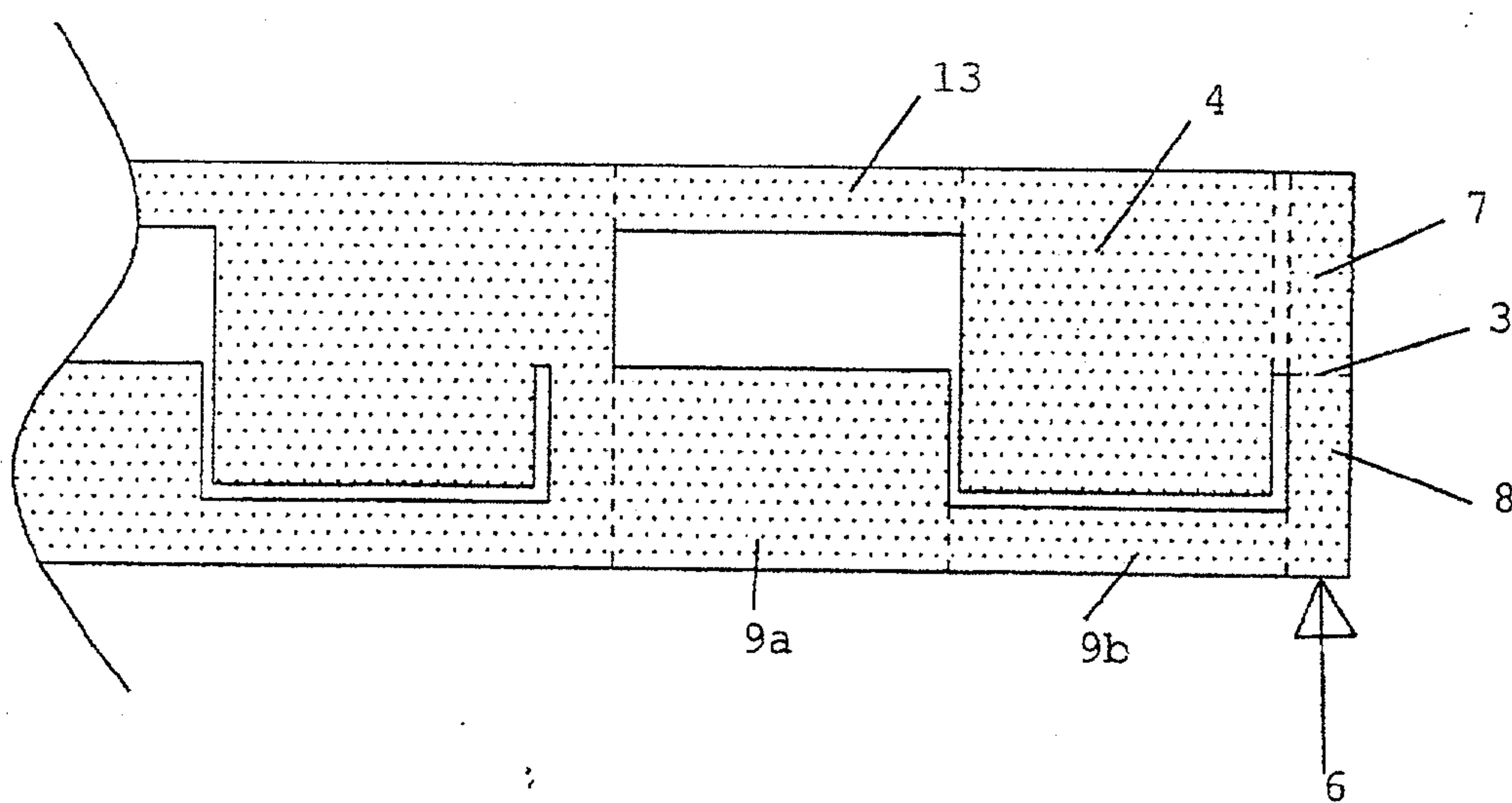

FIG. 4b

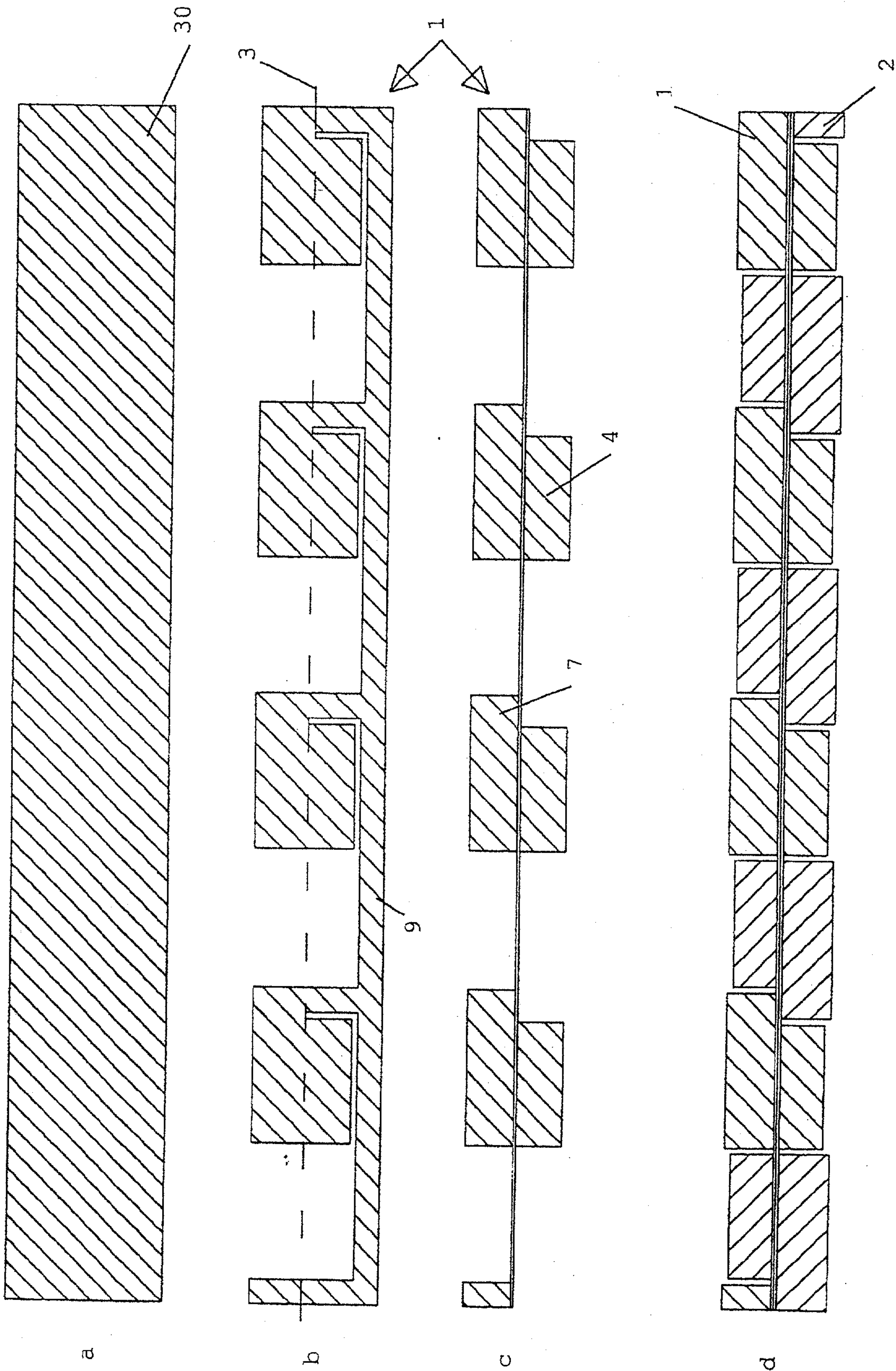

FIG. 5

6/7

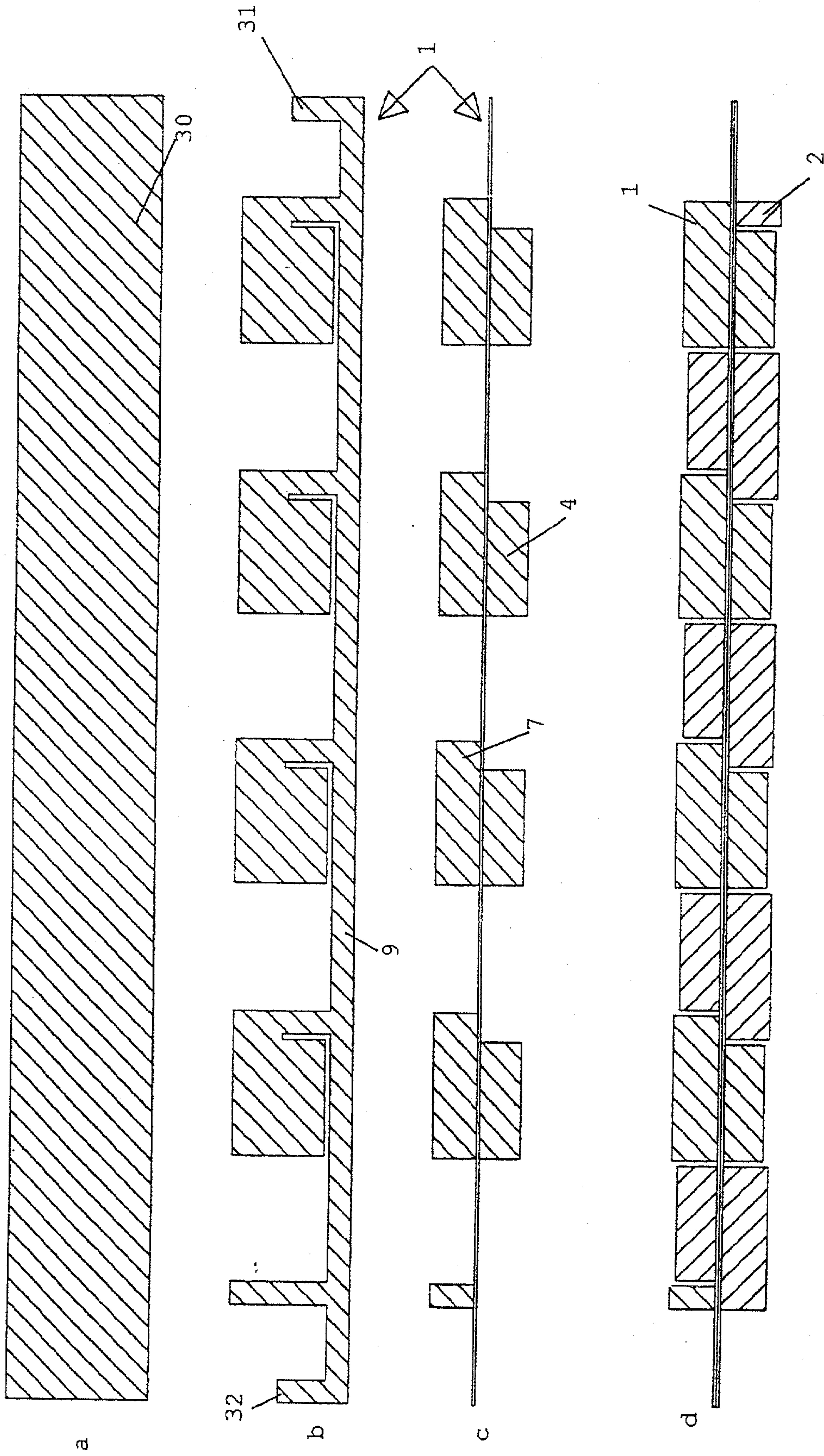

FIG. 6

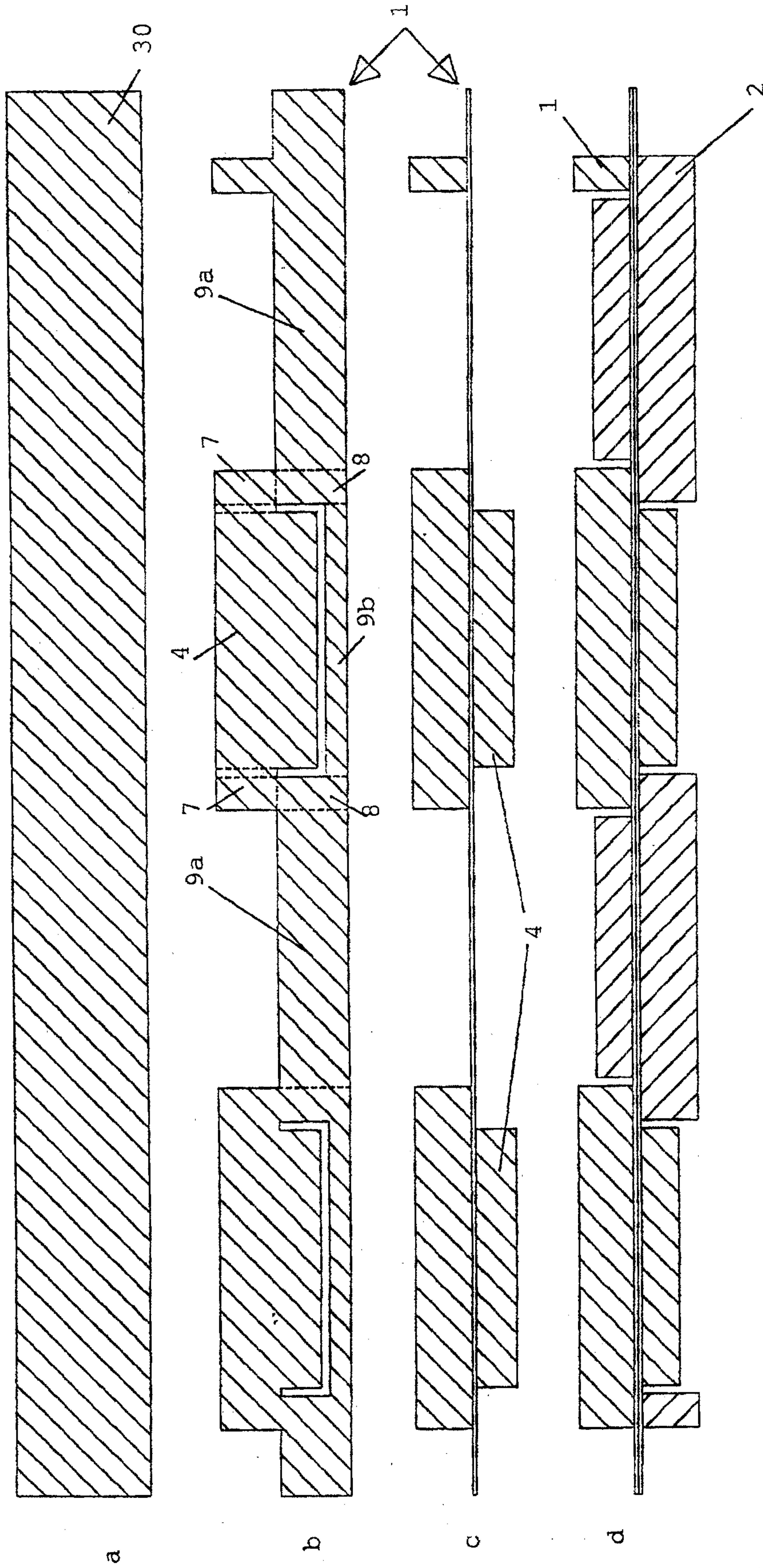

FIG. 7

