

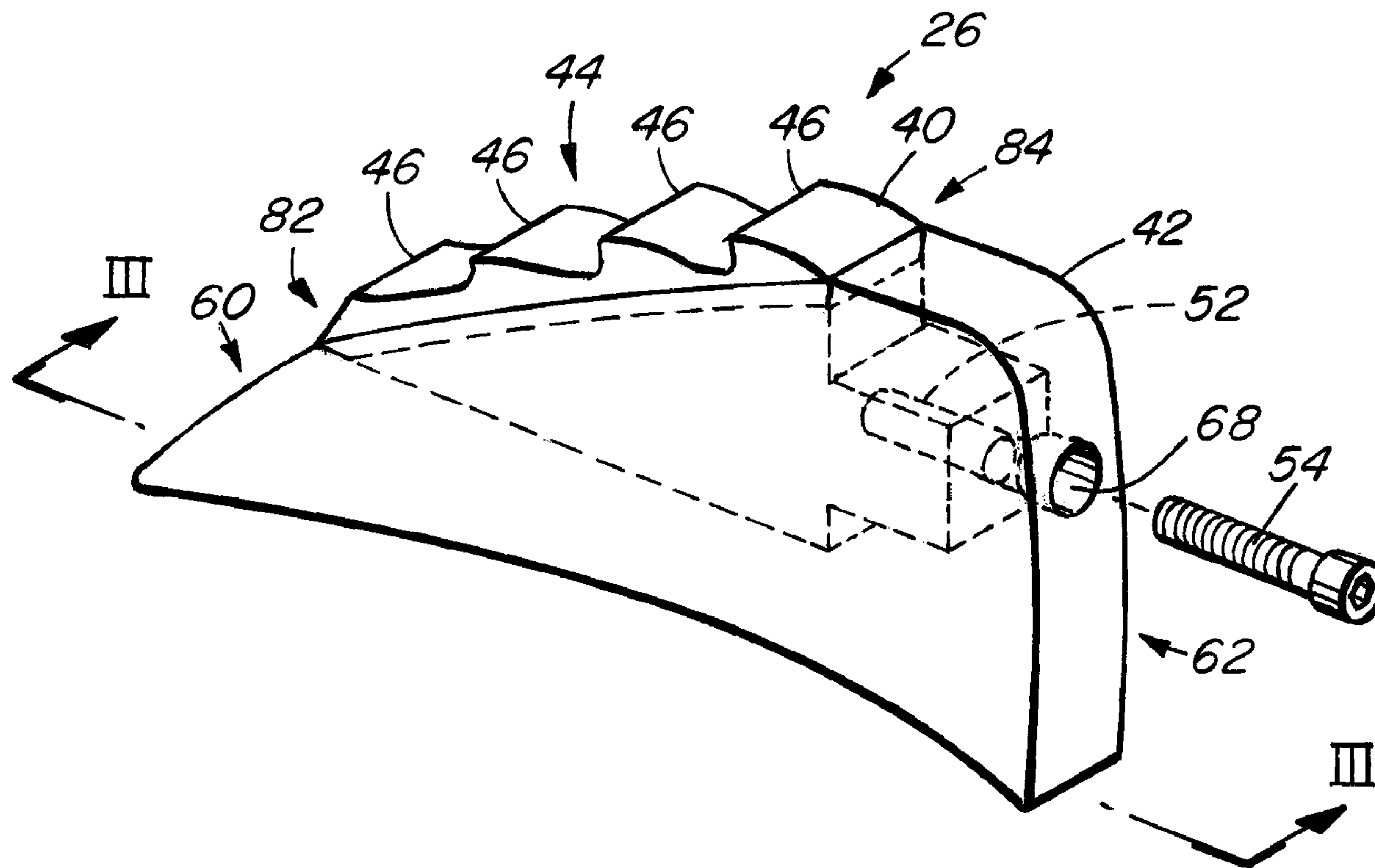

(22) **Date de dépôt/Filing Date:** 2008/10/30
 (41) **Mise à la disp. pub./Open to Public Insp.:** 2010/04/30
 (45) **Date de délivrance/Issue Date:** 2015/04/28

(51) **Cl.Int./Int.Cl.** *B27L 1/05* (2006.01),
B02C 18/18 (2006.01), *B02C 4/30* (2006.01),
B27B 33/12 (2006.01), *B27L 1/02* (2006.01),
B27L 1/10 (2006.01)
 (72) **Inventeurs/Inventors:**
 DURANT, MICHAEL J., CA;
 MACEY, C. TODD, CA;
 MCNICOL, ROBERT M., CA
 (73) **Propriétaire/Owner:**
 KADANT CANADA CORP., CA
 (74) **Agent:** FETHERSTONHAUGH & CO.

(54) **Titre :** ECORCEUSE
 (54) **Title:** DEBARKING APPARATUS



(57) **Abrégé/Abstract:**

A debarking apparatus includes a cutting body having a cutting surface and a first projection configured to cooperate with a fastener. The debarking apparatus also includes a holding body for removably holding the cutting body, the holding body having a trailing surface and defining a first recess generally complementary to the first projection to receive therein the first projection in a close surrounding fit, and a first opening sized to receive the fastener. The fastener is configurable to pass through the first opening and to cooperate with the first projection and with the holding body to hold the first projection in the first recess in a close surrounding fit.

ABSTRACT OF THE DISCLOSURE

A debarking apparatus includes a cutting body having a cutting surface and a first projection configured to cooperate with a fastener. The debarking apparatus also includes a holding body for removably holding the cutting body, the holding body having a trailing surface and defining a first recess generally complementary to the first projection to receive therein the first projection in a close surrounding fit, and a first opening sized to receive the fastener. The fastener is configurable to pass through the first opening and to cooperate with the first projection and with the holding body to hold the first projection in the first recess in a close surrounding fit.

DEBARKING APPARATUS

BACKGROUND OF THE INVENTION

1. Field of Invention

5 The invention relates generally to debarking, and more particularly to a debarking apparatus including a cutting body and a holding body for removably holding the cutting body.

2. Description of Related Art

10 Some types of debarking machines for removing bark from logs include a container for holding logs to be debarked, and also include one or more rotatable drums that protrude into the interior of the container. In these debarking machines, one or more debarking teeth may be mounted to an outer circumference of the rotatable drums, such that in operation, rotation of
15 the rotatable drums may cause the debarking teeth to engage with logs that are in the container, to remove bark from the logs.

Prolonged use of these types of debarking machines may cause the debarking teeth to be abraded. Also, different configurations of the debarking
20 teeth may be desirable for different applications. For example, more aggressive debarking teeth may be preferable in winter conditions when logs may be frozen, or for logs of harder wood species of trees. Therefore, it may be desirable for cutting teeth to include a detachable cutting portion that can be removed and replaced with a new, sharpened, or different cutting portion.

25 In one known arrangement, a debarking tooth includes a platform (which may also be referred to as a "shoe") and a blade tip plate (which may also be referred to as a "cutting block"). The blade tip plate in this arrangement includes a plurality of tooth portions, and defines three through holes through
30 a top cutting surface of the blade tip plate. Bolts may pass through respective through holes in the blade tip plate and engage respective female screw portions in the platform, to attach the blade tip plate to the platform.

- 2 -

5 A debarking machine may include hundreds of blade tip plates, and removing and replacing blade tip plates in the aforementioned type of arrangement may be cumbersome and time-consuming. The biggest problem in the field is that the wear that the top surfaces of the blade tip plates encounter in normal debarking use also affects the bolts holding the plates in place. In some cases, the wear at the bolt head is severe enough that the bolt head is not deep enough to receive a wrench to engage and rotate the bolt. If this happens, it may be necessary to weld an extension onto the bolt to provide sufficient purchase for the wrench to loosen and remove the bolt.

10

As well, because the through openings for receiving the fasteners are on the top cutting surface of the blade tip plate, debris from debarking (such as wood, bark, or mud, for example) may become lodged in the through openings, potentially interfering with attempts to remove or replace the blade tip plates by impeding use of tools to remove the bolts. Furthermore, it has been found that in these types of arrangements, three bolts may be required to fix the blade tip plate securely to the platform, adding to the time and expense that may be involved in removing and replacing the blade tip plates.

15

20 **SUMMARY OF THE INVENTION**

Accordingly, the present invention provides a debarking apparatus comprising:

25

a cutting body having a cutting surface and a first abutting surface, the cutting body including a first projection projecting from the first abutting surface, the first projection being configured to cooperate with a fastener; and

30

a holding body for removably holding the cutting body, the holding body having a leading surface, a trailing surface, and a second abutting surface, the holding body defining a first recess in the second abutting surface and defining a first opening extending between the first recess and the trailing surface, the second abutting surface being generally complementary to the first abutting surface for removable abutment with the first abutting surface, the first opening being sized

- 3 -

to receive the fastener, and the first recess being generally complementary to the first projection to receive therein the first projection in a close surrounding fit when the first abutting surface abuts the second abutting surface;

5 wherein when the first abutting surface abuts the second abutting surface, the cutting surface is exposed for debarking and the fastener is configurable to pass through the first opening and to cooperate with the first projection and with the holding body to hold the first projection in the first recess in a close surrounding fit and to hold the first abutting surface against the second abutting surface.

10

In a further aspect, the present invention provides A debarking apparatus comprising:

15 a cutting body having a cutting surface and a first abutting surface, the cutting body including a first projection projecting from the first abutting surface, the first projection being configured to receive a fastener; and

20 a holding body for removably holding the cutting body, the holding body having a leading surface, a trailing surface, and a second abutting surface, the holding body defining a first recess in the second abutting surface and defining a first opening extending between the first recess and the trailing surface, the second abutting surface being generally complementary to the first abutting surface for releasable abutment with the first abutting surface, and the first recess being generally complementary to the first projection to receive therein the first projection in a close surrounding fit when the first abutting surface abuts the second abutting surface;

25

30 wherein when the first abutting surface abuts the second abutting surface, the cutting surface is exposed for debarking and the fastener is extendable through the first opening in the trailing surface of the cutting body to engage the first projection to hold the cutting body against the holding body.

Other aspects and features of the present invention will become apparent to those ordinarily skilled in the art upon review of the following description of specific embodiments of the invention in conjunction with the accompanying figures.

5

BRIEF DESCRIPTION OF THE DRAWINGS

In drawings which illustrate embodiments of the invention,

Figure 1 is a perspective view of an exemplary debarking machine,

Figure 2 is a partially exploded perspective view of a debarking apparatus shown in Figure 1,

10

Figure 3 is a cross section view of the debarking apparatus shown in Figure 2, taken along line III shown in Figure 2,

Figure 4 is a perspective view of a cutting body shown in Figures 2 and 3,

Figure 5 is a cross sectional view of the cutting body shown in Figure 4, taken along the line V shown in Figure 4,

15

Figure 6 is a cross sectional view of the cutting body shown in Figure 4, taken along line VI shown in Figure 4,

Figure 7 is a perspective view of a holding body shown in Figures 2 and 3,

Figure 8 is a cross sectional view of the holding body shown in Figure 7, taken along the line VIII shown in Figure 7,

20

Figure 9 is a cross sectional view of the holding body shown in Figure 7, taken along the line IX shown in Figure 7,

Figure 10 is a perspective view of an alternative debarking apparatus,

Figure 11 is a cross sectional view of the debarking apparatus shown in Figure 10, taken along the line XI shown in Figure 10,

25

Figure 12 is a perspective view of a cutting body shown in Figures 10 and 11, and

Figure 13 is a cross sectional view of a holding body shown in Figures 10 and 11, taken along the line XIII shown in Figure 10.

30

DESCRIPTION OF THE PREFERRED EMBODIMENTS

Referring to Figure 1, an exemplary debarking machine is shown generally at 10. Debarking machine 10 includes a housing 12 that defines a debarking

- 5 -

region shown generally at **14**. Debarking machine **10** further includes a hopper **16** for organizing logs or other material to be debarked (not shown). Logs or other material may be supplied to hopper **16** using a conveyer mechanism **19**, for example, for subsequent delivery by gravity into the debarking region **14** of housing **12**.

5

Debarking machine **10** further includes a rotary debarker **20**, which in the illustrated example is a generally cylindrical drum rotatable about an axis of rotation shown generally at **22**. Often debarker **20** comprises two or more cylindrical drums rotatable within housing **12**. Each drum of rotary debarker **20** has a generally cylindrical exterior surface **24**, and at least one debarking apparatus **26** coupled to exterior surface **24**. In the illustrated example, a plurality of debarking apparatuses **26** are coupled to exterior surface **24** in a generally helical arrangement. Therefore, in the illustrated example, when rotary debarker **20** is rotated in the direction indicated by arrow **28**, logs or other material released from holder **16** through opening **18** will generally be urged longitudinally along debarking region **14** in a direction indicated by arrow **30**. Further details regarding exemplary debarking machines may be found in United States Patent No. **5,647,418** to Ishizawa.

10

15

20

Referring to Figures **2** and **3**, debarking apparatus **26** is shown in greater detail. Debarking apparatus **26** includes a cutting body **40** and a holding body **42** for removably holding the cutting body.

25

30

Referring to Figures **4**, **5**, and **6**, cutting body **40** is shown in greater detail. Cutting body **40** has a cutting surface shown generally at **44**, which preferably includes at least one or a plurality of cutting teeth **46**. Cutting body **40** also has a first abutting surface shown generally at **48**, and a first projection **50** projecting from first abutting surface **48**. First projection **50** preferably includes a threaded bore **52** for receiving a fastener, such as a bolt **54** illustrated in Figures **2** and **3**, for example. First projection **50** is thus configured to cooperate with a fastener such as hex bolt **54**, although alternatively,

- 6 -

projection **50** may be configured to cooperate with other types of fasteners. Cutting body **40** may be made from a conventional hardened material such as ASTM A732 10Q (also known as 4340 carbon steel), and may be hardened to a Rockwell hardness between Rc **53** and Rc **55**, for example.

5

Referring to Figures **7**, **8**, and **9**, holding body **42** is shown in greater detail. Holding body **42** has a leading surface shown generally at **60** and a trailing surface shown generally at **62**. Referring back to Figure **1**, debarking apparatus **26** may be positioned on exterior surface **24** of rotary debarker **20** such that when rotary debarker **20** rotates in the direction shown by arrow **28**, leading surface **60** is on a leading side of debarking apparatus **26** and trailing surface **62** is on a trailing side of debarking apparatus **26**. However, leading surface **60** and trailing surface **62** are not dependent on the actual positioning of debarking apparatus **26** on a debarking drum, or on movement of a debarking drum.

10

15

Referring back to Figures **7**, **8**, and **9**, holding body **42** also has a second abutting surface shown generally at **64**, and second abutting surface **64** is generally complementary to first abutting surface **48** of the cutting body shown in Figures **4**, **5**, and **6**, such that first abutting surface **48** may removably abut second abutting surface **64**. Holding body **42** also defines a first recess **66** in second abutting surface **64**, and first recess **66** is generally complementary to first projection **50** of the cutting body shown in Figures **4** and **5**, such that first projection **50** may be received in first recess **66** in a close surrounding fit when first abutting surface **48** abuts second abutting surface **64**, to hold cutting body **40** securely in holding body **42**. Holding body **42** also defines a first opening **68** extending between first recess **66** and trailing surface **62**, first opening **68** being sized to receive bolt **54** illustrated in Figures **2** and **3**, for example, or to receive any fastener with which first projection **50** is configured to cooperate. Holding body **42** may be made from a material such as **1020** carbon steel, and may be made as a cast only so that no hardening is required.

20

25

30

- 7 -

Referring again to Figures 4 and 6, first abutting surface 48 preferably includes first and second opposite and spaced apart lateral surfaces 70 and 72 adjacent cutting surface 44, and referring to Figure 9, second abutting surface 64 preferably includes third and fourth opposite and spaced apart lateral surfaces 74 and 76 generally complementary to first and second lateral surfaces 70 and 72, respectively. Second abutting surface 64 thus preferably defines a cavity 78 for receiving cutting body 40. Advantageously, lateral surfaces 70 and 72 may abut lateral surfaces 74 and 76, respectively, and may cooperate to prevent lateral movement of cutting body 40 relative to holding body 42 when first abutting surface 48 abuts second abutting surface 64. Referring to Figure 2, preferably only cutting surface 44 of cutting body 40 is exposed when cutting body 40 is received in cavity 78.

Referring now to Figures 7 and 8, holding body 42 preferably also has a coupling surface 80 configured for mounting to a portion of exterior surface 24 of rotary debarker 20 as illustrated in Figure 1. Coupling surface 80 preferably includes a concave portion generally complementary to the portion of exterior surface 24, such that debarking apparatus 26 is coupleable (by welding, for example) to the portion of exterior surface 24 with leading surface 60 and trailing surface 62 positioned as shown in Figure 1.

Referring again to Figures 2 and 3, when first abutting surface 48 abuts second abutting surface 64, cutting body 40 and holding body 42 preferably form a debarking assembly generally having a wedge shape. In the preferable configuration illustrated in Figures 2 and 3, when first abutting surface 48 abuts second abutting surface 64, cutting surface 44 generally adjoins leading surface 60 and trailing surface 62 at adjoining points illustrated generally at 82 and 84 respectively. Thus, cutting body 40 and holding body 42, when in the configuration illustrated in Figures 2 and 3, preferably form a generally contiguous cutting shape for use in debarking machine 10 illustrated in Figure 1. Cutting body 40 may be installed in holding body 42 by abutting first abutting surface 48 against second abutting surface 64. In this configuration, cutting surface 44 is exposed for debarking, and bolt 54 may be passed

- 8 -

through first opening **68** and received in threaded bore **52** to cooperate with first projection **50** and with holding body **42** to hold first projection **50** in first recess **66** in a close surrounding fit, and to hold first abutting surface **48** against second abutting surface **64**.

5

Advantageously, cutting surface **44** is preferably exposed in a region of debarking apparatus **26** that will impact logs for debarking the logs, when cutting apparatus **26** is installed and used in debarking machine **10** generally in the manner illustrated in Figure **1**. Therefore, wear from debarking over time will preferably be borne primarily on cutting surface **44**. When cutting surface **44** has been worn to an undesirable extent, or when a cutting surface having a different configuration is desirable (for debarking logs of a different species of trees or for debarking in different environmental conditions, for example), cutting body **40** may be removed from holding body **42** by removing bolt **54** from threaded bore **52**. A new, different, or sharpened cutting body, for example, may then be installed in holding body **42**. Advantageously, because of the close surrounding fit of first projection **50** in first recess **66** and because of the various points of abutment of abutting surfaces **48** and **64**, a single fastener, illustrated as bolt **54**, may be sufficient to hold cutting body **40** in holding body **42**, desirably simplifying installation and removal of cutting bodies from holding body **42** when compared to conventional three-bolt arrangements, for example. Furthermore, the positioning of bolt **54** through first opening **68** in trailing surface **62**, as illustrated in Figures **2** and **3** may advantageously prevent debris (such as bark, wood, mud, or other debris) from interfering with installation of cutting body **40**, in or removal of cutting body **40** from, holding body **42**.

15

Referring to Figures **10** and **11**, an alternative debarking apparatus is shown generally at **100**. Debarking apparatus **100** includes a cutting body **102** and a holding body **104** for removably holding cutting body **102**. Debarking apparatus **100**, cutting body **102**, and holding body **104** are generally similar to debarking apparatus **26**, cutting body **40**, and holding body **42** respectively. However, referring to Figure **12**, cutting body **102** has a first abutting surface

20

25

30

- 9 -

106, and first and second projections **108** and **110** projecting from first abutting surface **106**. Projections **108** and **110** include respective threaded bores **112** and **114** for receiving first and second bolts **116** and **118**, respectively, as illustrated in Figures **10** and **11**. Projections **108** and **110** are thus configured to cooperate with bolts **116** and **118** respectively. Alternatively, projections **108** and **110** may be configured to cooperate with other types of respective fasteners.

Referring to Figure **13**, holding body **104** includes a second abutting surface **120** generally complementary to first abutting surface **106** of the cutting body shown in Figure **12**, and holding body **104** defines first and second recesses **122** and **124** generally complementary to first and second projections **108** and **110**, respectively, of the cutting body (shown in Figure **12**). First recess **122** receives first projection **108** in a close surrounding fit and second recess **124** receives second projection **110** in a close surrounding fit when first abutting surface **106** abuts second abutting surface **120**. Still referring to Figure **13**, holding body **104** also defines first and second openings shown generally at **126** and **128**, sized to receive first and second bolts **116** and **118** respectively, as illustrated in Figures **10** and **11**, or any other fasteners with which projections **108** and **110** are configured to cooperate. Thus, cutting body **102** may be installed in holding body **104** using first and second bolts **116** and **118** to cooperate with first and second projections **108** and **110**, and with holding body **104**, to hold first projection **108** in first recess **122** in a close surrounding fit, to hold second projection **110** in second recess **124** in a close surrounding fit, and to hold first abutting surface **106** against second abutting surface **120**.

Thus, in operation, debarking apparatus **100** may be installed on exterior surface **24** of rotary debarker **20** illustrated in Figure **1**, in a manner described above for debarking apparatus **26**, for debarking logs or other material.

While specific embodiments of the invention have been described and illustrated, such embodiments should be considered illustrative of the

- 10 -

invention only and not as limiting the invention as construed in accordance with the accompanying claims.

The embodiments of the invention in which an exclusive property or privilege is claimed are define as follows:

1. A debarking apparatus comprising:

5

a cutting body having a cutting surface and a first abutting surface, the cutting body including a first projection projecting from the first abutting surface, the first projection being configured to cooperate with a fastener; and

10

a holding body for removably holding the cutting body, the holding body having a leading surface, a trailing surface, and a second abutting surface, the holding body defining a first recess in the second abutting surface and defining a first opening extending between the first recess and the trailing surface, the second abutting surface being generally complementary to the first abutting surface for removable abutment with the first abutting surface, the first opening being sized to receive the fastener, and the first recess being generally complementary to the first projection to receive therein the first projection in a close surrounding fit when the first abutting surface abuts the second abutting surface;

15

20

25

30

wherein when the first abutting surface abuts the second abutting surface, the cutting surface is exposed for debarking and the fastener is configurable to pass through the first opening and to cooperate with the first projection and with the holding body to hold the first projection in the first recess in a close surrounding fit and to hold the first abutting surface against the second abutting surface.

2. The debarking apparatus of claim 1 wherein the cutting surface comprises at least one cutting tooth.

3. The debarking apparatus of claim 1 wherein the cutting surface comprises a plurality of cutting teeth.
- 5 4. The debarking apparatus of claim 1, 2 or 3 wherein when the first abutting surface abuts the second abutting surface, the cutting body and the holding body form a debarking assembly generally having a wedge shape.
- 10 5. The debarking apparatus of any one of claims 1 to 4 wherein when the first abutting surface abuts the second abutting surface, the cutting surface generally adjoins the leading surface and the trailing surface.
- 15 6. The debarking apparatus of any one of claims 1 to 5 wherein the first abutting surface includes first and second opposite and spaced apart lateral surfaces adjacent the cutting surface, and wherein the second abutting surface includes third and fourth opposite and spaced apart lateral surfaces generally complementary to the first and second lateral surfaces respectively.
- 20 7. The debarking apparatus of any one of claims 1 to 6 wherein the second abutting surface defines a cavity for receiving the cutting body, and wherein only the cutting surface of the cutting body is exposed when the cutting body is received in the cavity.
- 25 8. The debarking apparatus of any one of claims 1 to 7 wherein the holding body further has a coupling surface configured for being coupled to a portion of an exterior surface of a rotary debarker rotatable about an axis of the rotary debarker.
- 30 9. The debarking apparatus of claim 8 wherein the coupling surface includes a concave portion generally complementary to the portion of the exterior surface of the rotary debarker.

10. The debarking apparatus of any one of claims **1** to **9**:

5

wherein the cutting body further includes a second projection projecting from the first abutting surface and spaced apart from the first projection, the second projection being configured to cooperate with a second fastener;

10

wherein the holding body defines a second recess in the second abutting surface, the second recess being separated from the first recess and generally complementary to the second projection to receive therein the second projection in a close surrounding fit when the first abutting surface abuts the second abutting surface;

15

wherein the holding body defines a second opening extending between the second recess and the trailing surface, the second opening being sized to receive the second fastener; and

20

wherein when the first abutting surface abuts the second abutting surface, the second fastener is configurable to pass through the second opening and to cooperate with the second projection and with the holding body to hold the second projection in the second recess in a close surrounding fit and to hold the first abutting surface against the second abutting surface.

25

11. A debarking apparatus comprising:

30

a cutting body having a cutting surface and a first abutting surface, the cutting body including a first projection projecting from the first abutting surface, the first projection being configured to receive a fastener; and

5 a holding body for removably holding the cutting body, the
holding body having a leading surface, a trailing surface, and a
second abutting surface, the holding body defining a first recess
in the second abutting surface and defining a first opening
extending between the first recess and the trailing surface, the
second abutting surface being generally complementary to the
first abutting surface for releasable abutment with the first
10 abutting surface, and the first recess being generally
complementary to the first projection to receive therein the first
projection in a close surrounding fit when the first abutting
surface abuts the second abutting surface;

15 wherein when the first abutting surface abuts the second
abutting surface, the cutting surface is exposed for debarking
and the fastener is extendable through the first opening in the
trailing surface of the cutting body to engage the first projection
to hold the cutting body against the holding body.

20

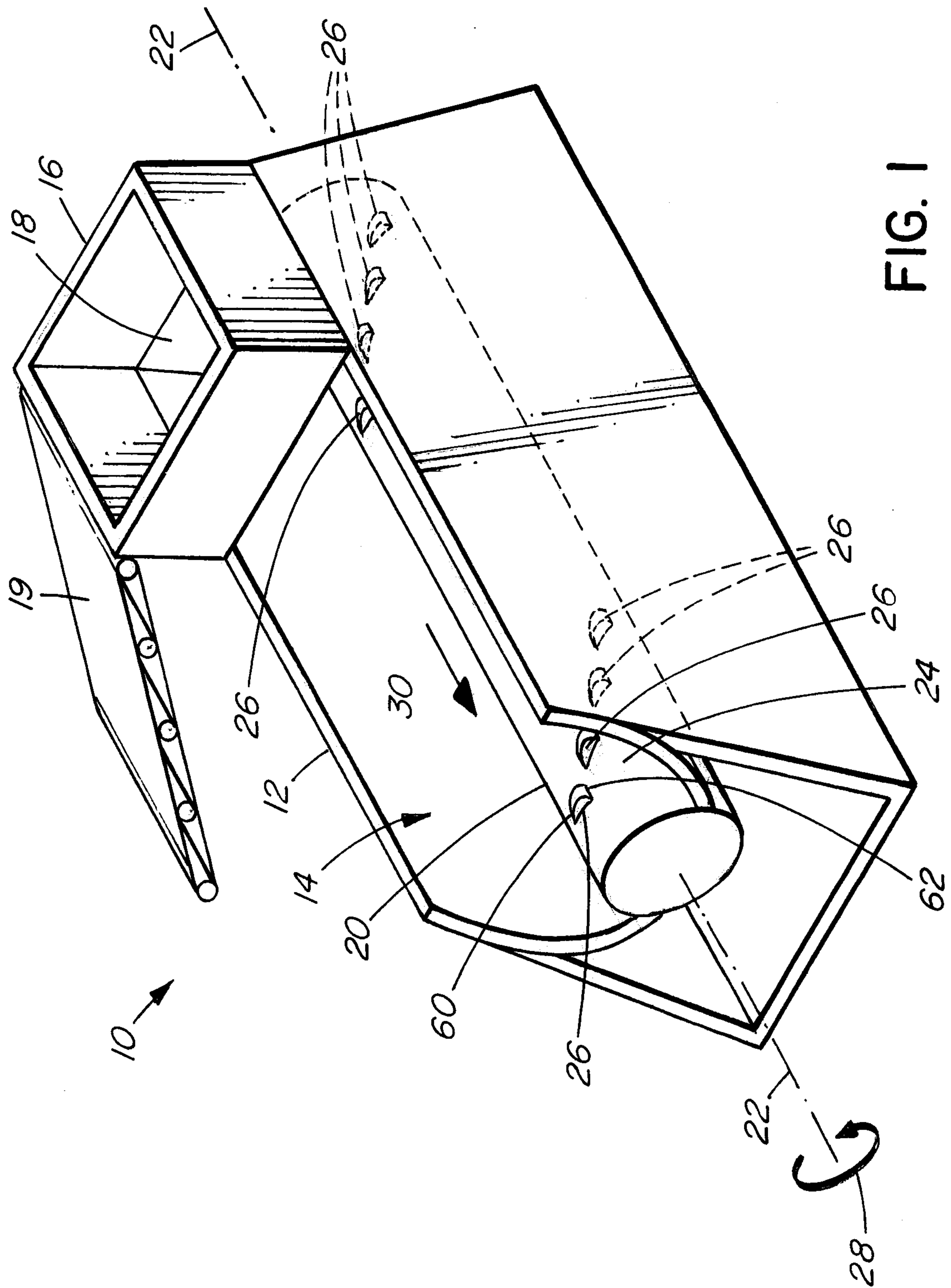

FIG. 1

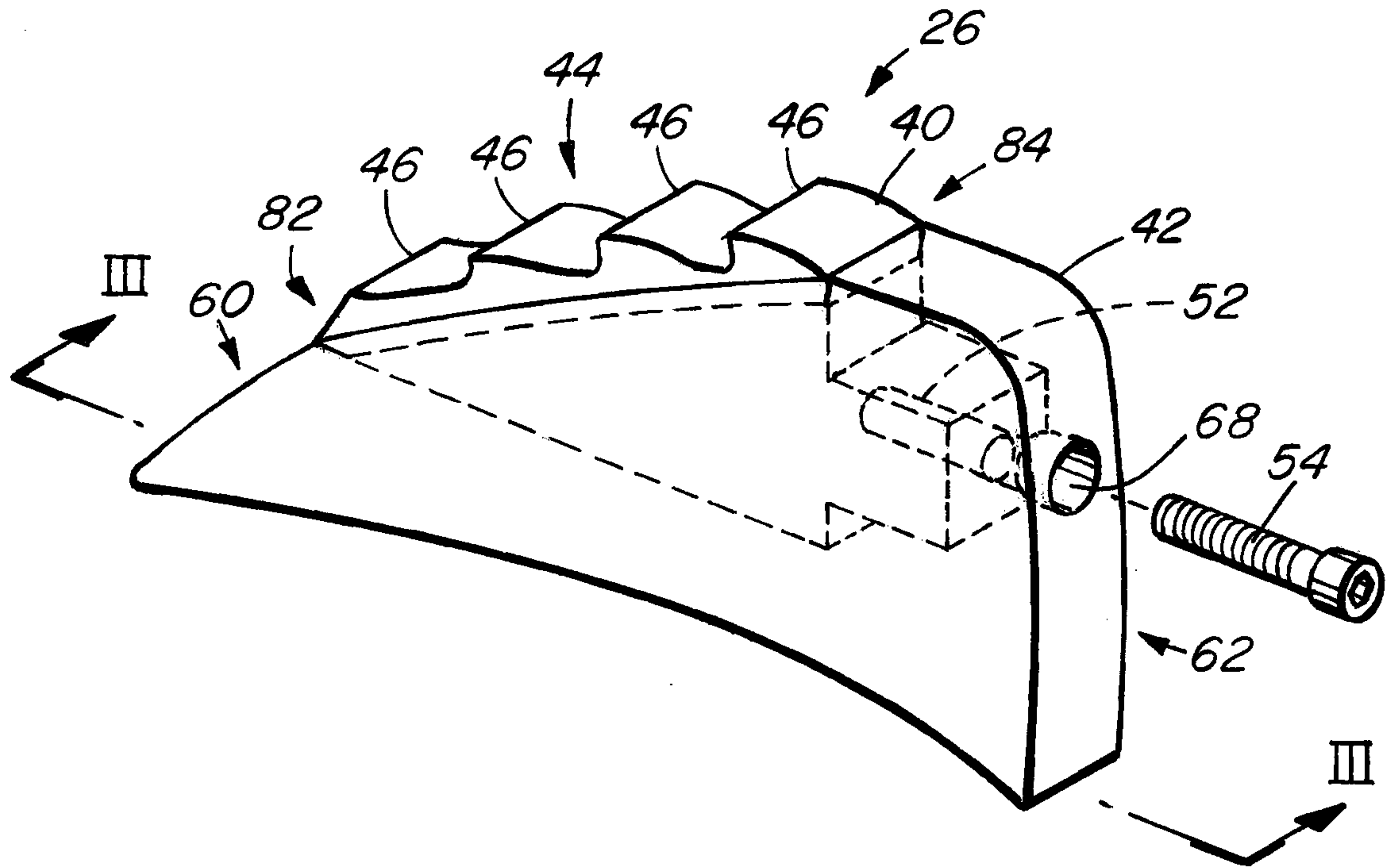

FIG. 2

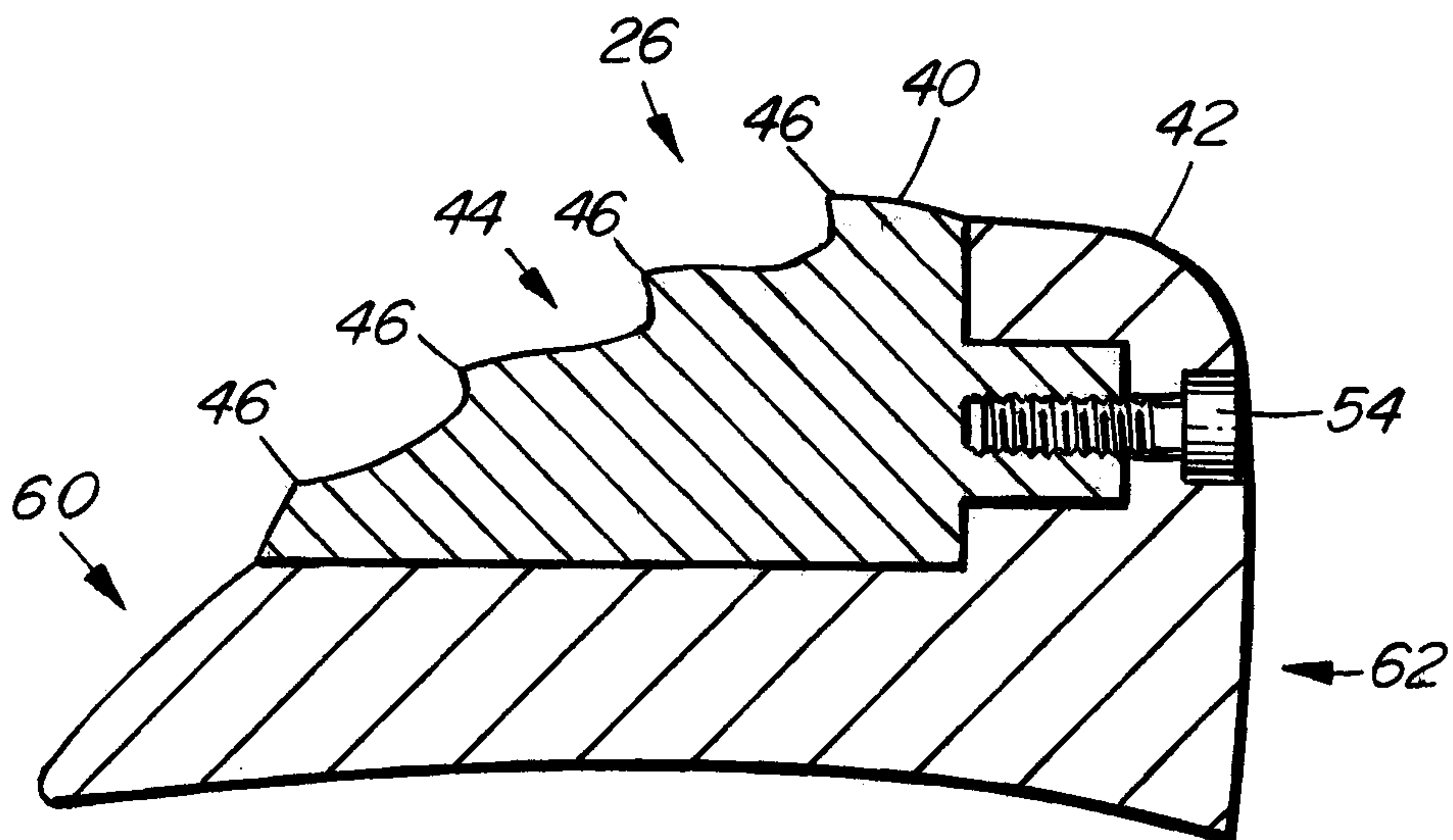

FIG. 3

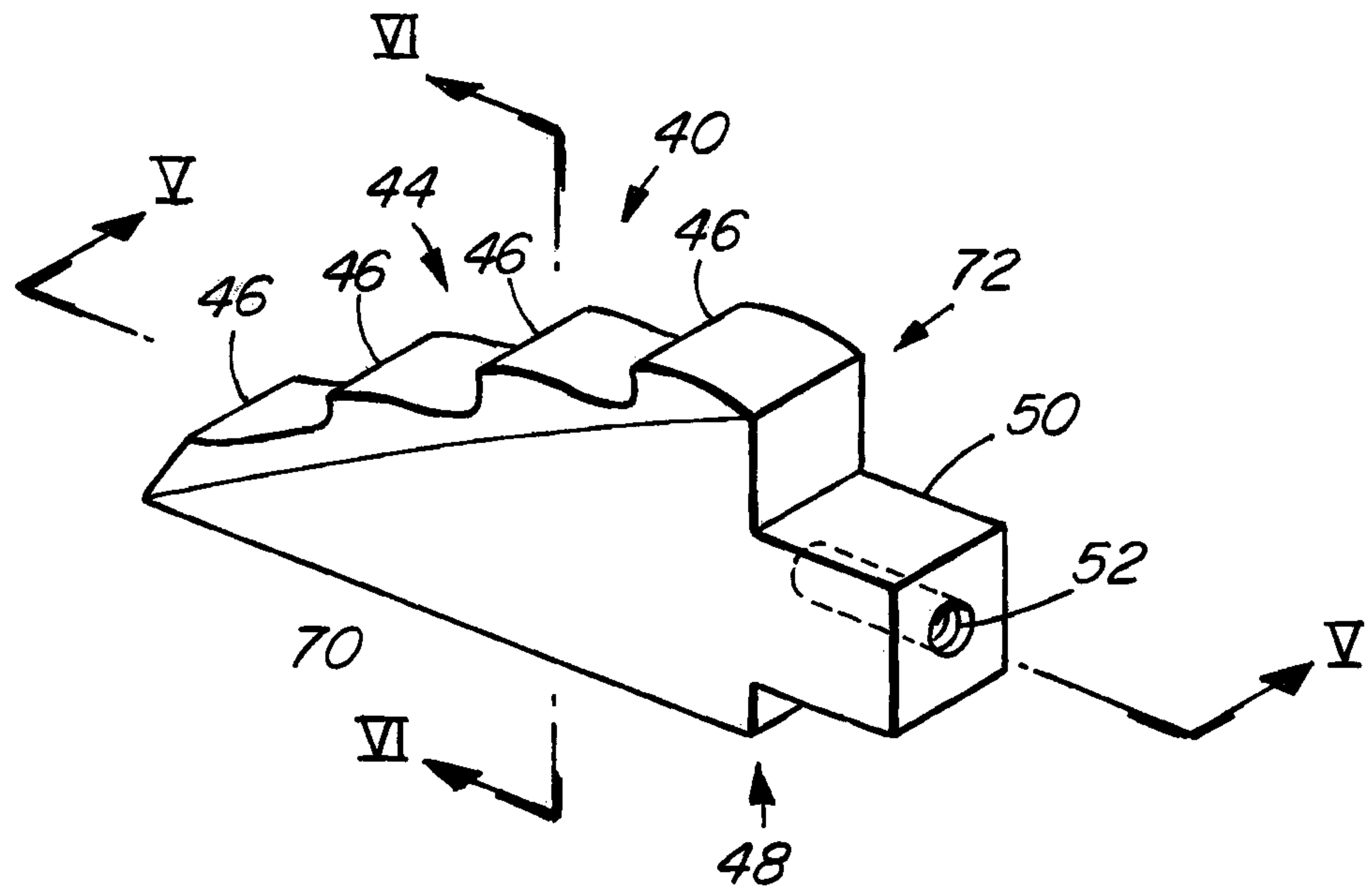

FIG. 4

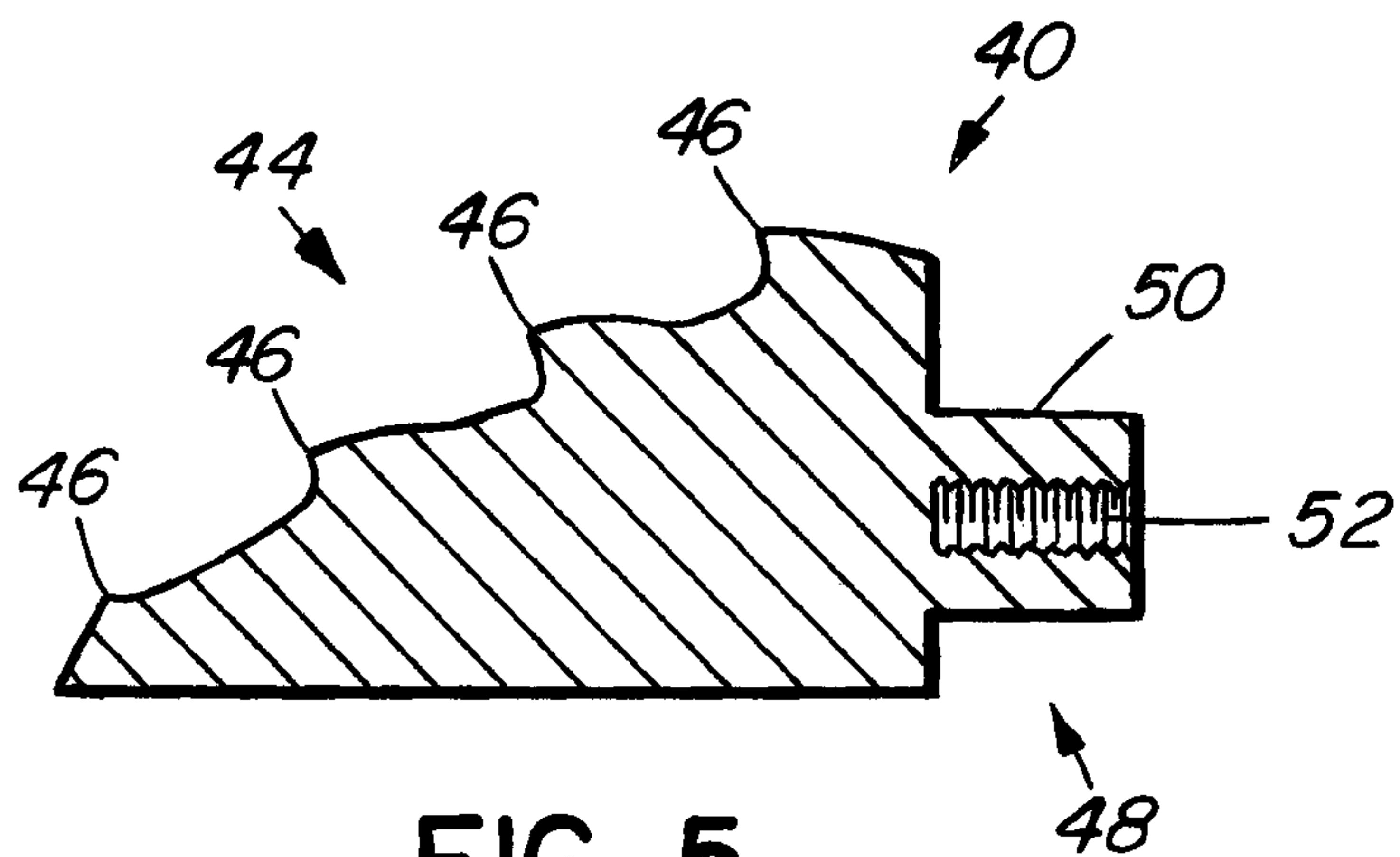

FIG. 5

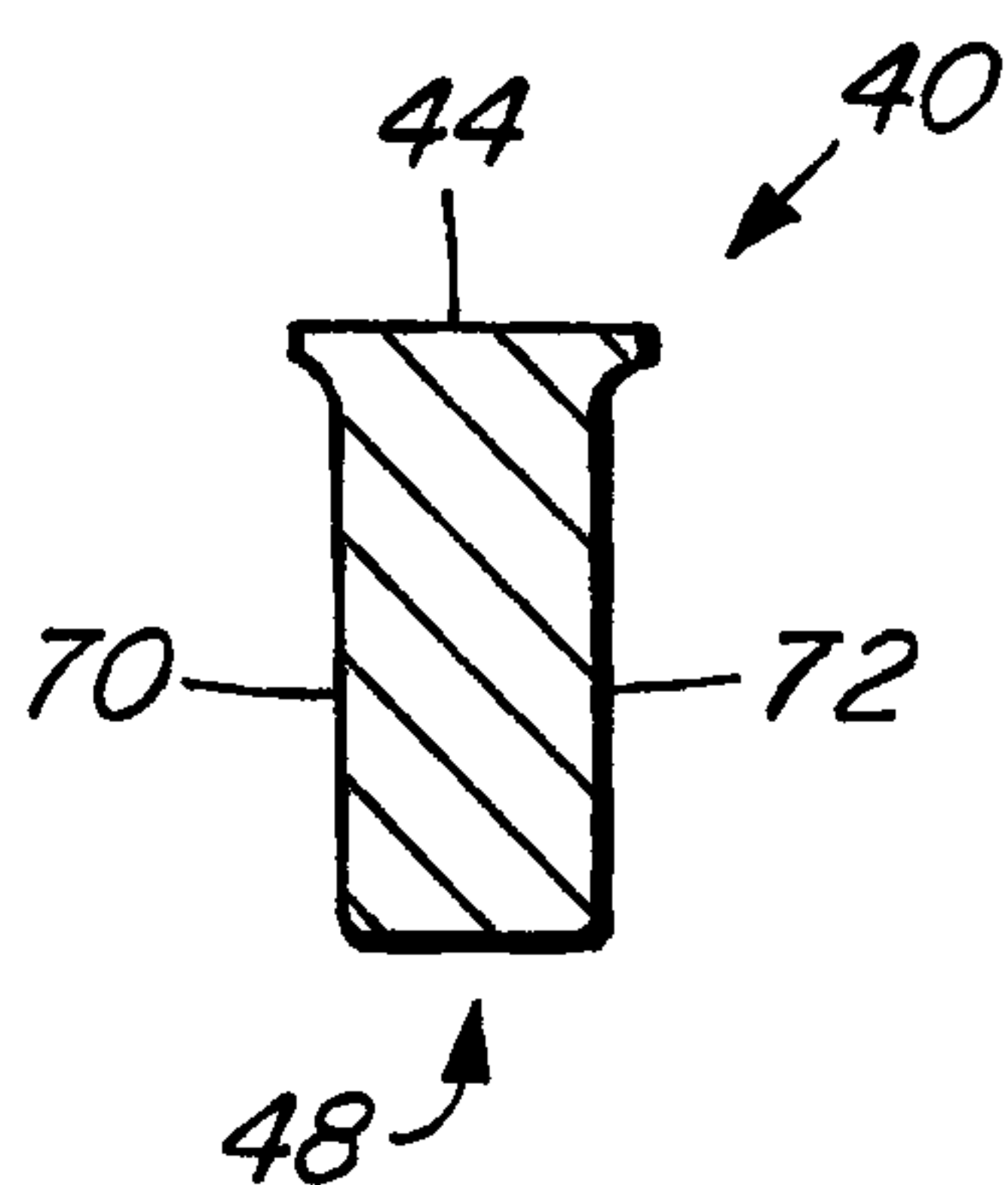

FIG. 6

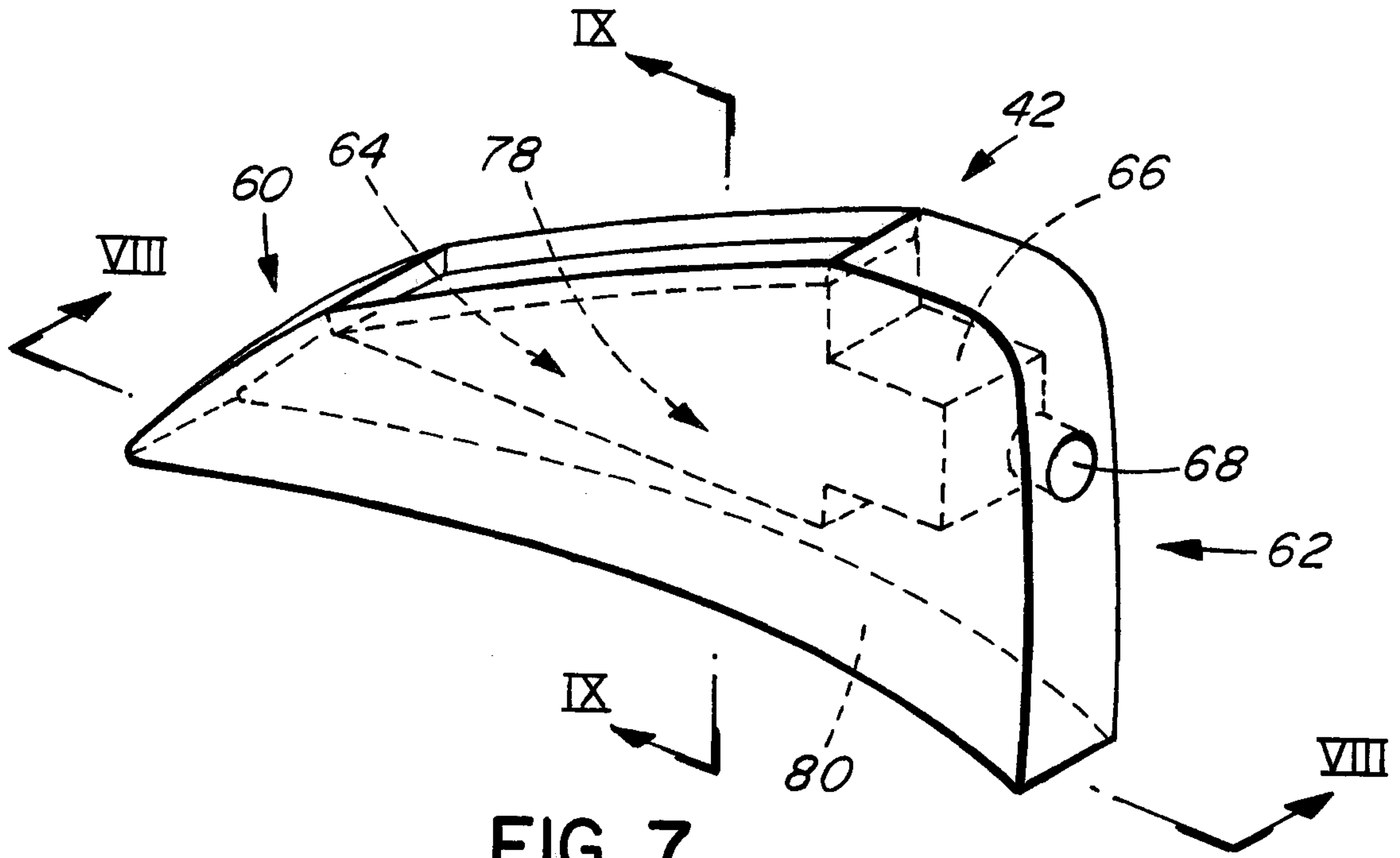

FIG. 7

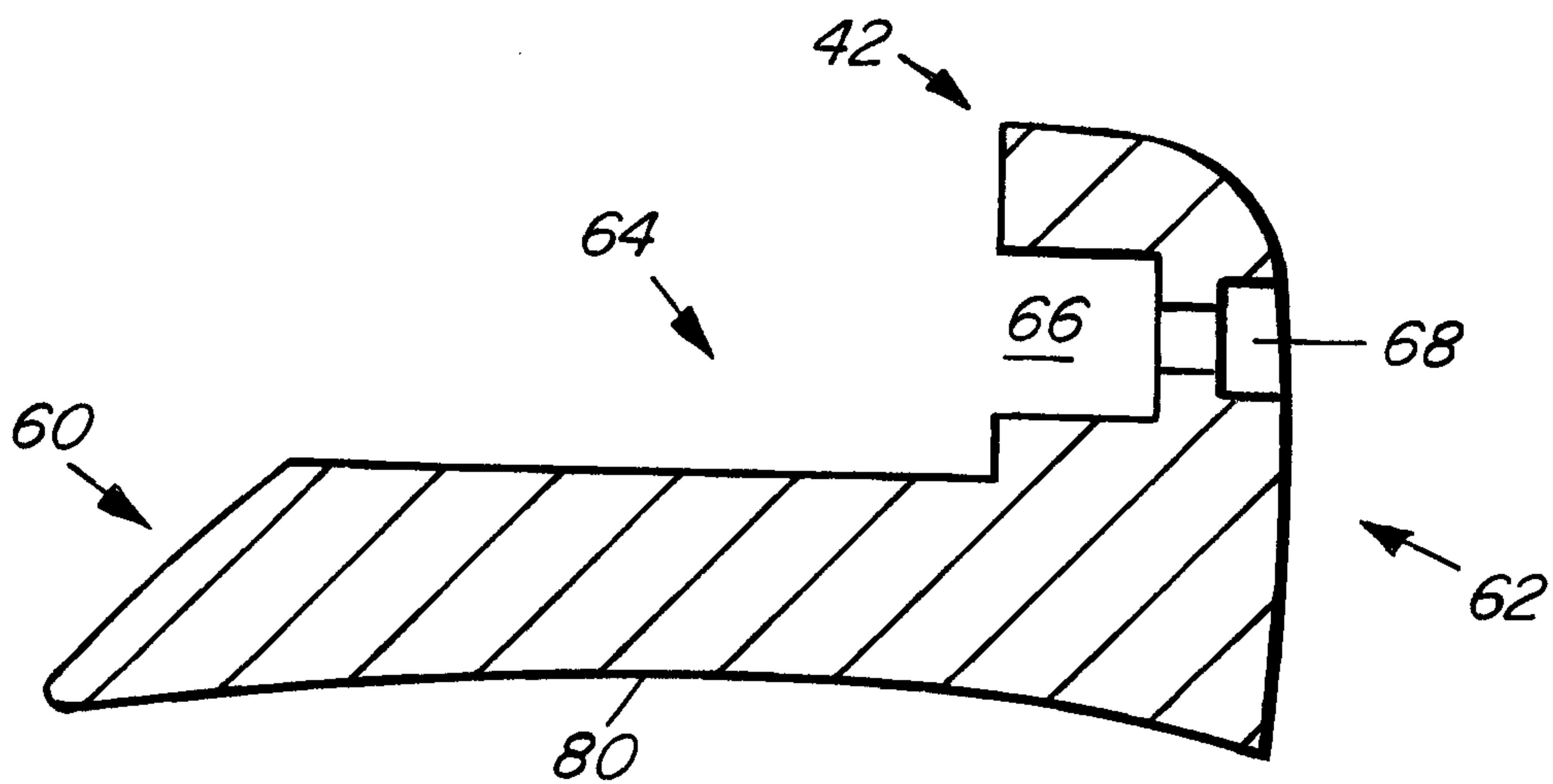

FIG. 8

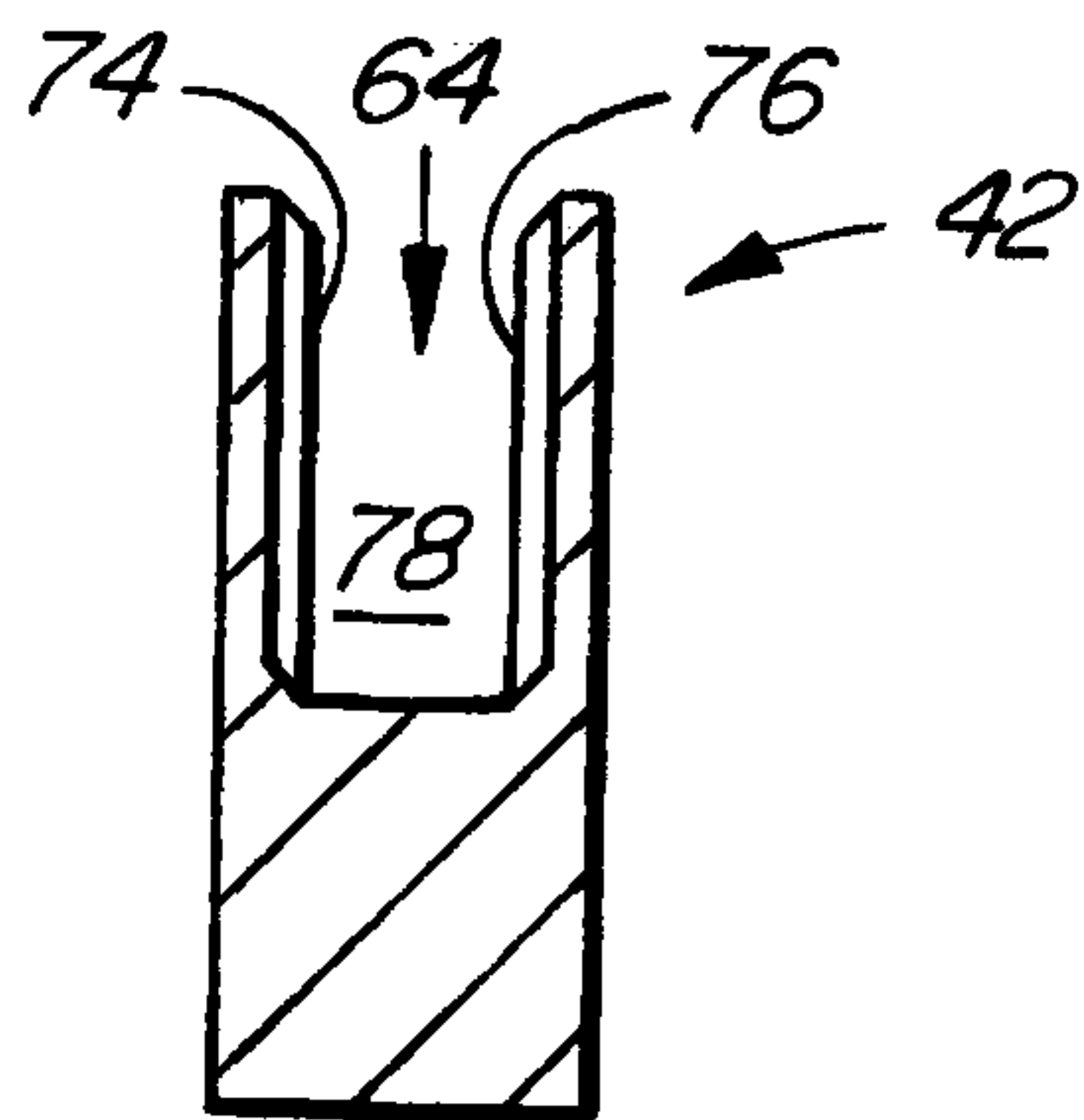

FIG. 9

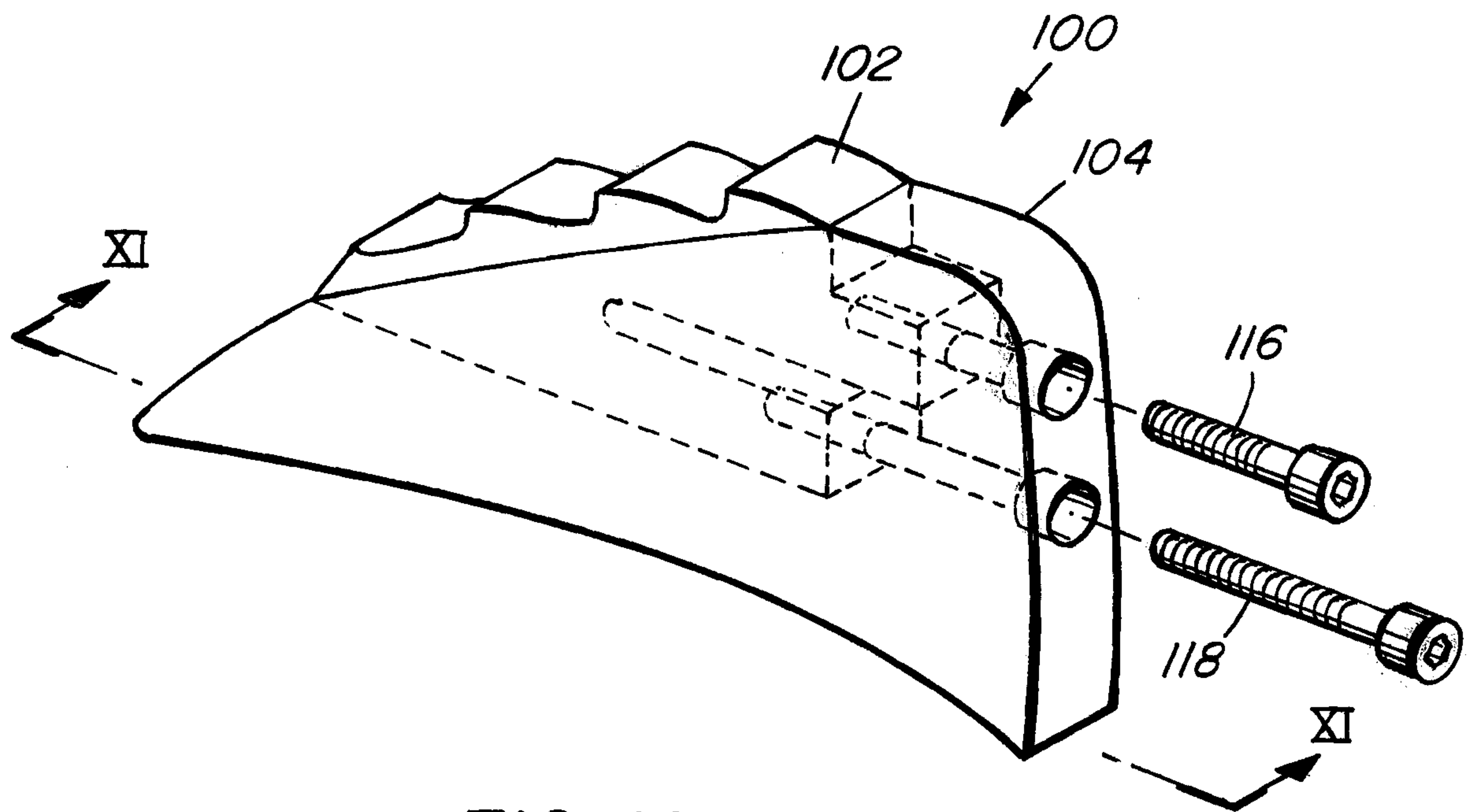

FIG. 10

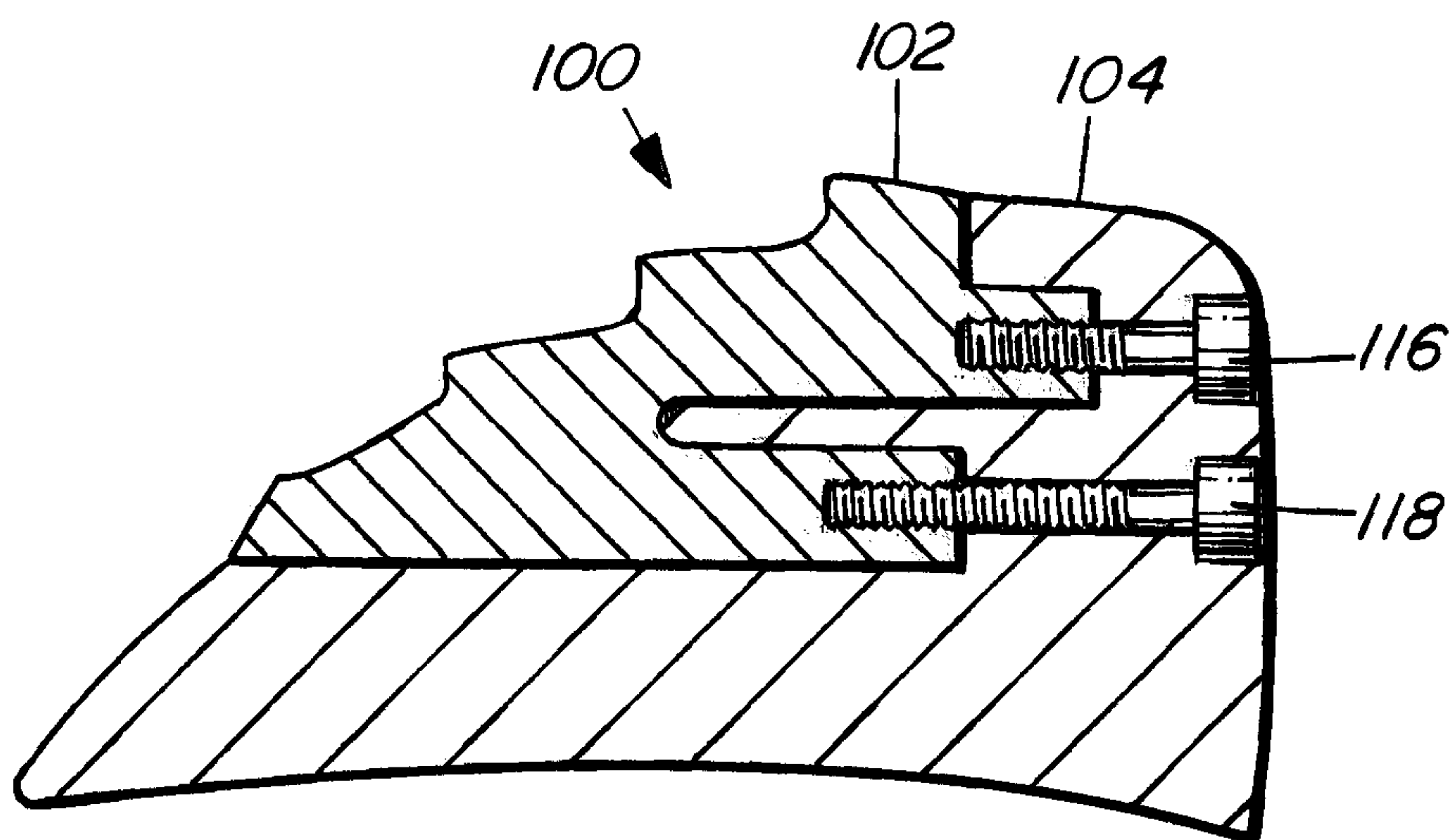

FIG. II

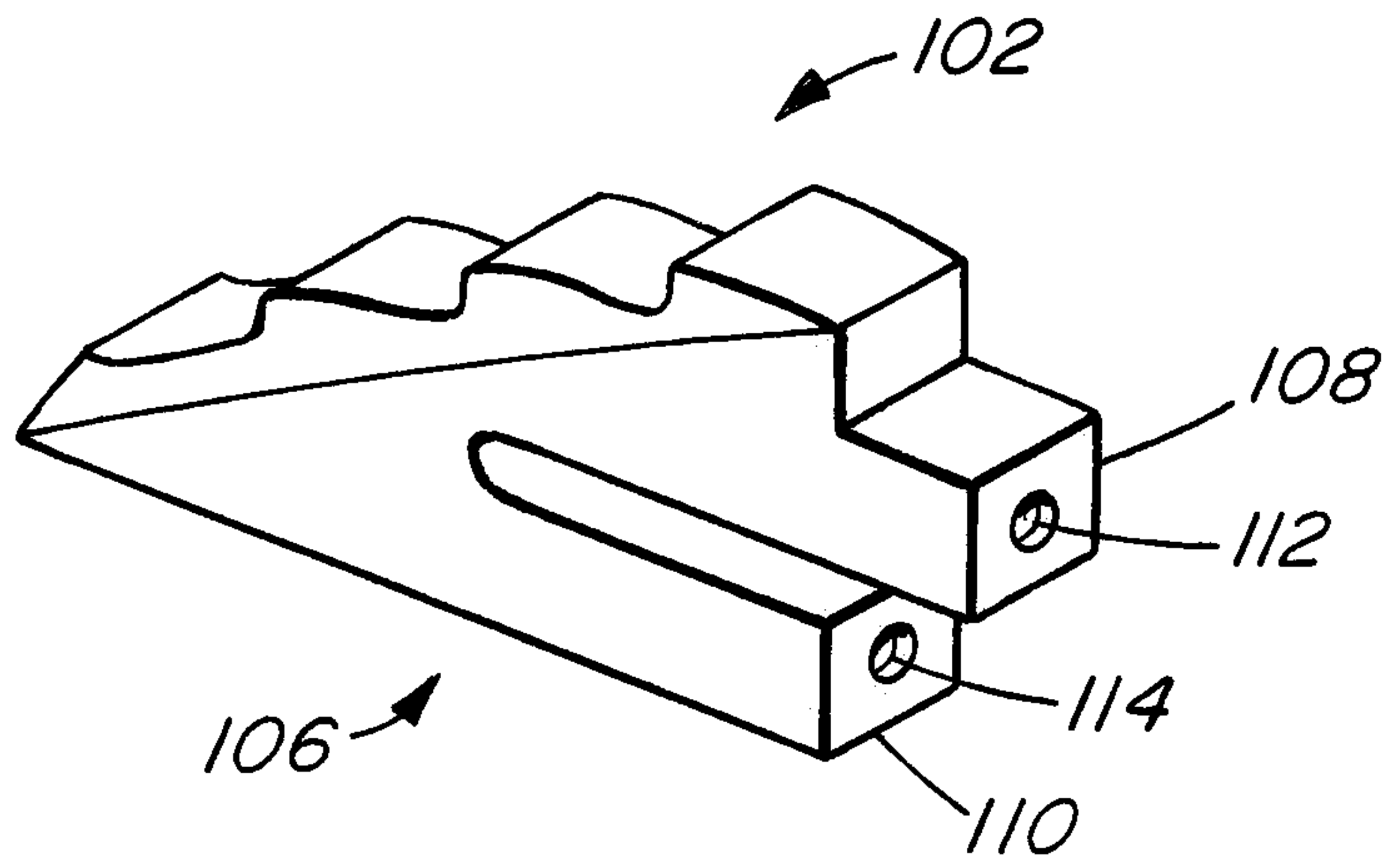

FIG. 12

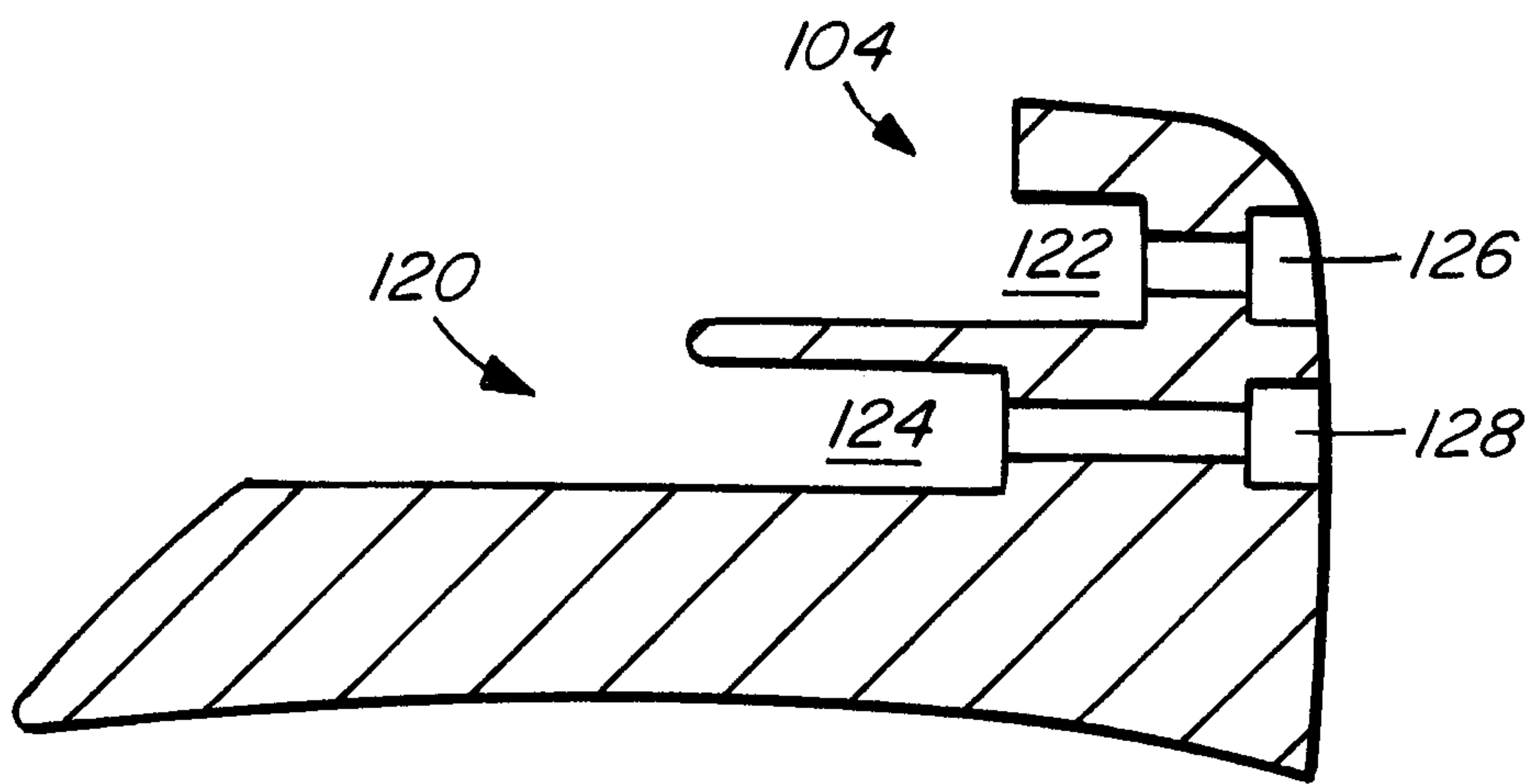

FIG. 13

