



(51) International Patent Classification:

A61M 25/06 (2006.01) A61B 17/22 (2006.01)
A61M 29/02 (2006.01)

(21) International Application Number:

PCT/US2012/055079

(22) International Filing Date:

13 September 2012 (13.09.2012)

(25) Filing Language:

English

(26) Publication Language:

English

(30) Priority Data:

61/534,018 13 September 2011 (13.09.2011) US

(72) Inventor; and

(71) Applicant : PIGOTT, John, P. [US/US]; 4539 Dove-wood, Sylvania, OH 43560 (US).

(74) Agent: BONDY, Brent, L.; MacMillan, Sobanski & Todd, LLC, One Maritime Plaza, 5th Floor, 720 Water Street, Toledo, OH 43604 (US).

(81) Designated States (unless otherwise indicated, for every kind of national protection available): AE, AG, AL, AM, AO, AT, AU, AZ, BA, BB, BG, BH, BN, BR, BW, BY, BZ, CA, CH, CL, CN, CO, CR, CU, CZ, DE, DK, DM,

DO, DZ, EC, EE, EG, ES, FI, GB, GD, GE, GH, GM, GT, HN, HR, HU, ID, IL, IN, IS, JP, KE, KG, KM, KN, KP, KR, KZ, LA, LC, LK, LR, LS, LT, LU, LY, MA, MD, ME, MG, MK, MN, MW, MX, MY, MZ, NA, NG, NI, NO, NZ, OM, PA, PE, PG, PH, PL, PT, QA, RO, RS, RU, RW, SC, SD, SE, SG, SK, SL, SM, ST, SV, SY, TH, TJ, TM, TN, TR, TT, TZ, UA, UG, US, UZ, VC, VN, ZA, ZM, ZW.

(84) Designated States (unless otherwise indicated, for every kind of regional protection available): ARIPO (BW, GH, GM, KE, LR, LS, MW, MZ, NA, RW, SD, SL, SZ, TZ, UG, ZM, ZW), Eurasian (AM, AZ, BY, KG, KZ, RU, TJ, TM), European (AL, AT, BE, BG, CH, CY, CZ, DE, DK, EE, ES, FI, FR, GB, GR, HR, HU, IE, IS, IT, LT, LU, LV, MC, MK, MT, NL, NO, PL, PT, RO, RS, SE, SI, SK, SM, TR), OAPI (BF, BJ, CF, CG, CI, CM, GA, GN, GQ, GW, ML, MR, NE, SN, TD, TG).

Published:

- with international search report (Art. 21(3))
- before the expiration of the time limit for amending the claims and to be republished in the event of receipt of amendments (Rule 48.2(h))

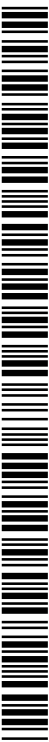

WO 2013/040160 A1

(54) Title: INTRAVASCULAR CATHETER HAVING AN EXPANDABLE INCISING PORTION

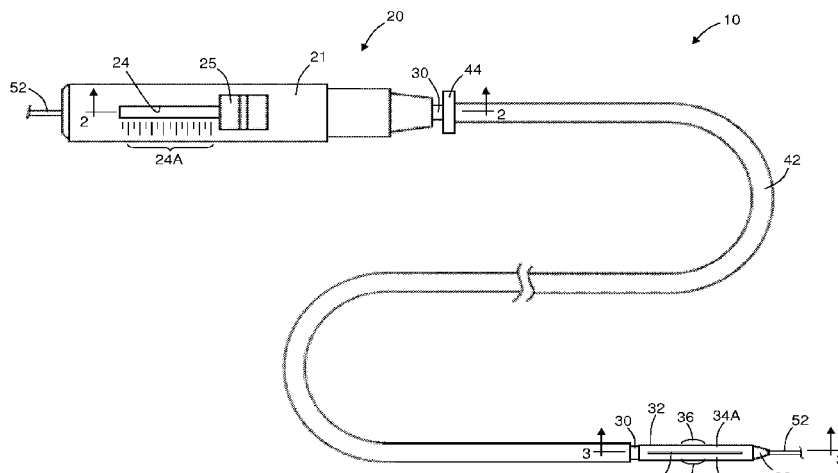

FIG. 1

(57) Abstract: An intravascular catheter device is provided for use during a surgical procedure. The catheter device includes a catheter tube having an expandable portion with a plurality of struts each defining an outer surface. The expandable portion is operable between a closed position, wherein the expandable portion has a first diameter, and an opened position, wherein the expandable portion has a second diameter that is larger than the first diameter. An incising element is provided on the outer surface of at least one of the struts. The incising element has a blade that extends outwardly in a radial direction from the outer surface of the strut for creating an incision in atherosclerotic material located within a blood vessel when the expandable portion is in the opened position.

TITLE

INTRAVASCULAR CATHETER HAVING AN EXPANDABLE INCISING
PORTION

CROSS-REFERENCE TO RELATED APPLICATIONS

[0001] This application claims the benefit of United States Provisional Application No. 61/534,018, filed September 13, 2011, the disclosure of which is incorporated herein by reference.

BACKGROUND OF THE INVENTION

[0002] This invention relates in general to intravascular catheters, such as can be used during minimally invasive surgical procedures. In particular, this invention relates to an intravascular catheter having an expandable incising portion.

[0003] Atherosclerosis is a chronic condition in which atheromatous plaque accumulates on the inner walls of a blood vessel. As a result, the blood vessel walls can become inflamed and, over time, may harden to form atherosclerotic lesions that cause a narrowing of the vessel lumen. In severe cases, the atherosclerotic lesions can rupture and induce the formation of thrombus (i.e., blood clots), which can prevent blood flow through the narrowed vessel lumen.

[0004] There are known procedures and devices for treating or otherwise reducing the risks associated with atherosclerosis. For example, an angioplasty is a procedure in which a balloon catheter is inserted into a narrowed region of the vessel lumen via a delivery catheter. The balloon catheter includes a flexible tube having an inflatable balloon at an end thereof. Once positioned in the narrowed region, the balloon is inflated in order to dilate the narrowed vessel lumen. The pressure in the balloon is generally sufficient to compress the accumulated plaque. However, in some cases it would be desirable to fragment the atherosclerotic lesions. Thus, it would be desirable to provide an intravascular catheter having an expandable portion that can be

selectively controlled by a user and adapted to create incisions in atherosclerotic material to facilitate fragmentation of the material during an angioplasty procedure.

SUMMARY OF THE INVENTION

[0005] This invention relates to an intravascular catheter device for use during a surgical procedure. The catheter device includes a catheter tube having an expandable portion with a plurality of struts each defining an outer surface. The expandable portion is operable between a closed position, wherein the expandable portion has a first diameter, and an opened position, wherein the expandable portion has a second diameter that is larger than the first diameter. An incising element is provided on the outer surface of at least one of the struts. The incising element has a blade that extends outwardly in a radial direction from the outer surface of the strut for creating an incision in atherosclerotic material located within a blood vessel when the expandable portion is in the opened position.

[0006] Various aspects of this invention will become apparent to those skilled in the art from the following detailed description of the preferred embodiments, when read in light of the accompanying drawings.

BRIEF DESCRIPTION OF THE DRAWINGS

[0007] Fig. 1 is a plan view of a catheter device that includes a handle assembly and a catheter tube having an expandable incising portion, in accordance with a first embodiment of this invention.

[0008] Fig. 2 is a cross-sectional side view of the handle assembly taken along section line 2-2 shown in Fig. 1 when the catheter device is in a first operating mode.

[0009] Fig. 3 is an enlarged cross-sectional side view of the catheter tube taken along section line 3-3 shown in Fig. 1 illustrating the expandable incising portion disposed within a blood vessel.

[0010] Fig. 4 is a cross-sectional end view of the expandable incising portion taken along section line 4-4 shown in Fig. 3.

- [0011]** Fig. 5 is a cross-sectional side view of the handle assembly taken along section line 2-2 shown in Fig. 1 when the catheter device is in a second operating mode.
- [0012]** Fig. 6 is an enlarged cross-sectional side view of the catheter tube taken along section line 3-3 shown in Fig. 1 illustrating the expandable incising portion in an opened position.
- [0013]** Fig. 7 is a cross-sectional end view of the expandable incising portion taken along section line 7-7 shown in Fig. 6.
- [0014]** Fig. 8 is an enlarged side view of a catheter tube having an expandable incising portion, in accordance with a second embodiment of this invention.
- [0015]** Fig. 9 is a side view of the catheter tube shown in Fig. 8 illustrating the expandable incising portion in an opened position.
- [0016]** Fig. 10 is a cross-sectional end view of the expandable incising portion taken along section line 10-10 shown in Fig. 9.
- [0017]** Fig. 11 is an enlarged side view of a catheter tube having an expandable incising portion, in accordance with a third embodiment of this invention.
- [0018]** Fig. 12 is a side view of the catheter tube shown in Fig. 11 illustrating the expandable incising portion in an opened position.
- [0019]** Fig. 13 is an end view of the catheter tube as shown in Fig. 12.
- [0020]** Fig. 14 is an enlarged side view of a catheter tube having an expandable incising portion, in accordance with a fourth embodiment of this invention.
- [0021]** Fig. 15 is a side view of the catheter tube shown in Fig. 14 illustrating the expandable incising portion in an opened position.
- [0022]** Fig. 16 is an end view of the catheter tube as shown in Fig. 15.

DETAILED DESCRIPTION OF THE PREFERRED EMBODIMENTS

- [0023]** Referring now to the drawings, there is illustrated in Fig. 1 a catheter device, indicated generally at 10, in accordance with this invention. The illustrated catheter device 10 is configured to treat or reduce the risks associated with atherosclerosis. In general, the catheter device 10 includes an expandable incising

portion that can be inserted into a blood vessel and expanded to create incisions in atherosclerotic material that has accumulated on inner walls of the blood vessel. The incisions facilitate the fragmentation of the atherosclerotic material during a subsequent angioplasty or atherectomy procedure. Although the catheter device 10 will be described and illustrated in the context of treating atherosclerosis, it should be appreciated that the catheter device 10 can be used in any desired environment and for any desired purpose.

[0024] Referring now to Figs. 1 and 2, the illustrated catheter device 10 includes a handle assembly, indicated generally at 20. The illustrated handle assembly 20 includes an elongated, cylindrical handle body 21. The handle body 21 may alternatively have any other shape that is suitable for easy handling by a surgeon. Further, the handle body 21 can be made from any suitably rigid material including, but not limited to, stainless steel or polymers.

[0025] As shown in Fig. 2, the illustrated handle body 21 defines an internal chamber 22. A passage 23 extends into an end portion of the handle body 21 for communication with the internal chamber 22. The handle body 21 further includes a slot 24 that extends through a side wall thereof for communication with the internal chamber 22. The illustrated slot 24 may have any length or width as desired. As shown in Fig. 1, an indicator 24A may be provided on the handle body 21 adjacent to the slot 24. For example, the indicator 24A can be a visual scale or any other indicating means, the purpose of which will be explained below.

[0026] The illustrated handle assembly 20 also includes a control member 25 that is supported on the handle body 21 for sliding movement within the slot 24. For example, the control member 25 is movable between a forward position (shown in Fig. 2), a rearward position (shown in Fig. 5), or any position therebetween, which will be further explained below. As shown in Fig. 2, the illustrated control member 25 includes a base portion 26 that is disposed within the internal chamber 22 of the handle body 21. The base portion 26 may define an outer cross-sectional shape that generally corresponds with a cross-sectional shape of the internal chamber 22, although such is not required. Alternatively (or in addition), the control member 25

may be movably supported on the handle body 21 by a bearing, a bushing, a guide rail, or any other structural means. In other embodiments, the control member 25 may be supported for rotational movement, pivotal movement, or any other type of movement relative to the handle body 21, the purpose of which will become apparent below. The visual indicator 24A, described above, is configured to identify the relative position of the control member 25 with respect to the handle body 21.

[0027] The illustrated handle assembly 20 also includes a locking mechanism 27 that is configured to temporarily secure the control member 25 in a desired position, although such is not required. As shown in Fig. 2, the illustrated locking mechanism 27 includes a plurality of protrusions that are spaced apart from one another along an inner surface of the slot 24. The control member 25 frictionally engages the protrusions to hold the control member 25 in the desired position. Alternatively, the locking mechanism 27 may be a threaded fastener, a pivotal latch, a push-button release, or any other mechanism that is configured to secure the control member 25 in a desired position.

[0028] Referring now to Figs. 1 through 3, the illustrated catheter device 10 also includes a catheter tube 30 that extends from the handle assembly 20. The catheter tube 30 is an elongated, flexible member having a proximal end that is secured to the handle assembly 20 and a distal end that extends therefrom. The catheter tube 30 can be made from any biocompatible material including, but not limited to, polyvinyl, polyethylene, nitinol, or stainless steel. Further, the catheter tube 30 can have any outer diameter, length, or wall thickness.

[0029] As shown in Fig. 2, the proximal end of the catheter tube 30 is secured to the handle body 21 and communicates with the internal cavity 22 through the passage 23. The catheter tube 30 may be secured to the handle body 21 using a flanged connection, a fused connection, an adhesive, a press-fit connection, a threaded connection, or any other securing means. Alternatively, the catheter tube 30 may be secured to the handle body 21 using a connector or any other type of attachment device.

[0030] As shown in Figs. 1 and 3, an expandable portion 32 is provided on the distal end of the catheter tube 30. The illustrated expandable portion 32 is a cylindrical member having a longitudinal axis. The expandable portion 32 can be made from a generally resilient material that is able to flex between various positions, such as polyvinyl, polyethylene, nitinol, or stainless steel. The expandable portion 32 can be secured to the catheter tube 30 in any manner including, but not limited to, a fused connection, an adhesive, a press-fit connection, a threaded connection, or any other securing means. Alternatively, the expandable portion 32 can be integrally formed from the catheter tube 30. Further, the expandable portion 32 can have any outer diameter, length, or wall thickness.

[0031] The illustrated expandable portion 32 has a pair of struts 34A and 34B. The illustrated struts 34A and 34B are separated by a pair of longitudinally extending slits 35A and 35B that extend through side walls of the expandable portion 32. As shown in Fig. 4, the slits 35A and 35B are equally spaced apart from one another around the circumference of the expandable portion 32 such that the struts 34A and 34B have the same circumferential widths, although such is not required. The struts 34A and 34B may have any length, circumferential width, or cross-sectional shape as desired.

[0032] As shown in Figs. 3 and 4, the illustrated expandable portion 32 also includes a pair of incising elements 36 that are respectively provided along outer surfaces of the struts 34A and 34B. The incising elements 36 can be atherotomes or other incising members having arcuate shaped blades, for example, that are configured to create incisions in atherosclerotic material as will be explained below. The illustrated incising elements 36 extend parallel with the longitudinal axis of the expandable portion 32 and outwardly in a radial direction therefrom. The incising elements 36 are equally spaced apart from one another around the circumference of the expandable portion 32. The expandable portion 32 may, however, have any number or configuration of incising elements 36 provided around the circumference thereof. Further, the incising elements 36 can have any cross-sectional shape, longitudinal length, or blade height and can be made from any suitable material including, but not limited to, tempered steel, stainless steel, high carbon steel, or

ceramics. The incising elements 36 can be molded with the struts 34A and 34B or may otherwise be secured thereto in any manner such as, for example, using a welded or soldered connection, an adhesive, or any other fastening means.

[0033] The distal end of the expandable portion 32 may optionally include a tip member 38. The illustrated tip member 38 has a generally conical shape that facilitates insertion of the catheter tube 30 within a blood vessel 50 (see Figs. 3 and 4) and subsequent travel therethrough. The tip member 38 may, however, have any desired shape. An aperture may axially extend through the tip member 38, the purpose of which will be explained below. The tip member 38 can be integrally formed with the expandable portion 32 or may be secured thereto, such as with an adhesive or the like. Further, the tip member 38 can be made from any biocompatible material including, but not limited to, polyvinyl, polyethylene, nitinol, stainless steel, or polyether block amide.

[0034] As shown in Figs. 2 through 4, the illustrated catheter device 10 also includes an inner sleeve 40, although such is not required. The inner sleeve 40 is a flexible, tubular member that is supported for sliding movement within the catheter tube 30, the purpose of which will be explained below. The inner sleeve 40 can be made from any biocompatible material including, but not limited to, polyvinyl, polyethylene, nitinol, stainless steel, or a woven material. Further, the inner sleeve 40 can have any outer diameter, length, or wall thickness. The inner sleeve 40 need not be a tubular member but may alternatively be a solid wire, a braided wire, or the like.

[0035] As shown in Fig. 2, a proximal end of the inner sleeve 40 extends from the catheter tube 30 and into the internal chamber 22 of the handle body 21. The proximal end of the inner sleeve 40 is secured to the base portion 26 of the control member 25 for sliding movement therewith, the purpose of which will be explained below. The inner sleeve 40 can be secured to the base portion 26 by a flanged connection, a fused connection, an adhesive, a threaded connection, or any other securing means.

[0036] As shown in Fig. 3, the inner sleeve 40 extends through an entire length of the catheter tube 30. A distal end of the inner sleeve 40 that is opposite the handle

assembly 20 is secured to the tip member 38, which is in turn secured to the expandable portion 32. The inner sleeve 40 may be secured to the tip member 38 in any manner including, but not limited to, a fused connection, an adhesive, a fastener, or the like.

[0037] Referring back to Figs. 1 and 2, the illustrated catheter device 10 also includes a protective sheath 42 that is supported for sliding movement along an outer surface of the catheter tube 30, although such is not required. The protective sheath 42 can be made from any biocompatible material including, but not limited to, polyvinyl, polyethylene, nitinol, or stainless steel. Further, the protective sheath 42 can have any outer diameter, length, or wall thickness. The purpose of the protective sheath 42 will be explained below.

[0038] The illustrated protective sheath 42 includes a flange 44 that facilitates sliding movement of the protective sheath 42 relative to the catheter tube 30. The illustrated flange 44 is an annular member that is located at an end of the protective sheath 42 nearest the handle assembly 20. The flange 44 can be integrally formed with the protective sheath 42 or may otherwise be secured thereto in any manner, such as with an adhesive or the like. It should be appreciated that the flange 44 can have any shape or may alternatively be configured in any manner to accomplish the functions described herein and below.

[0039] The operation of the catheter device 10 will now be described with reference to Figs. 1 through 7. Referring initially to Figs. 1 through 4, the catheter device 10 is illustrated in a first operating mode. In the first operating mode, the control member 25 on the handle assembly 20 is located in the forward position relative to the handle body 21. The inner sleeve 40 fully extends into the catheter tube 30 such that the expandable portion 32 is in a closed position, as shown in Figs. 3 and 4. In the closed position, the struts 34A and 34B are generally parallel with one another and with the inner sleeve 40. The slits 35A and 35B (illustrated by the dashed lines in Fig. 3) remain in a generally closed configuration. As such, the expandable portion 32 defines an initial diameter D1, which is generally the same diameter as the

remaining length of the catheter tube 30. The initial diameter D1 of the expandable portion 32 may, however, be any desired dimension.

[0040] When the catheter device 10 is in the first operating mode, the distal end of the catheter tube 30 can be percutaneously inserted into a blood vessel 50, as shown in Figs. 3 and 4. The illustrated catheter tube 30 is then advanced through the blood vessel 50 along a guide wire 52, which extends through the catheter device 10. For example, the guide wire 52 may fully extend through the inner sleeve 40, into the internal chamber 22 of the handle body 21, and exit a rear end of the handle assembly 20 (see Fig. 2). The catheter tube 30 is advanced along the guide wire 52 until the expandable portion 32 is positioned in a narrowed region of the blood vessel 50 caused by atherosclerotic material 54. Alternatively, the catheter tube 30 can be inserted into the blood vessel 50 and guided therethrough by a delivery catheter (not shown) or any other suitable procedure. During insertion and advancement of the catheter tube 30 through the blood vessel 50, the optional protective sheath 42 is preferably positioned over the expandable portion 32, thereby preventing the incising elements 36 from coming into contact with inner walls of the blood vessel 50.

[0041] Once the expandable portion 32 is positioned in the narrowed region of the blood vessel 50, the incising elements 36 can be exposed by sliding the protective sheath 42 back from the distal end of the catheter tube 30, as indicated by the direction arrows in Fig. 3. The illustrated protective sheath 42 can be moved in this manner by pulling the flange 44 towards the handle assembly 20, which is indicated by the direction arrows in Fig. 2.

[0042] Referring now to Figs. 5 through 7, the catheter device 10 is illustrated in a second operating mode. To achieve the second operating mode, the control member 25 is moved from the forward position to the rearward position, as indicated by the direction arrow in Fig. 5. As the control member 25 is moved to the rearward position, the inner sleeve 40 is drawn within the catheter tube 30 thereby reducing the relative length of the inner sleeve 40 with respect to the catheter tube 30. The distal end of the inner sleeve 40 is attached to the tip member 38, as described above, causing the expandable portion 32 to become axially compressed between the tip

member 38 and the distal end of the catheter tube 30. As a result, the struts 34A and 34B bow or expand outwardly in a generally arcuate fashion thereby defining an opened position. In the opened position, the expandable portion 32 defines a second diameter D2 that is larger than the initial diameter D1 when the expandable portion 32 is in the closed position. As shown in Fig. 6, the incising elements 36 are respectively positioned along the radially outer most surfaces of the struts 34A and 34B. Further, the outer most surfaces of the struts 34A and 34B may define a generally flat portion along a length thereof in the opened position, the purpose of which will be explained below, although such is not required. It should be appreciated that the struts 34A and 34B can have any lengths such that the expandable portion 32 can achieve a desired overall second diameter D2 in the opened position.

[0043] During operation of the catheter device 10, the second diameter D2 can be increased or decreased by selective movement of the control member 25 between the forward and rearward positions. For example, a larger second diameter D2 can be achieved by moving the control member 25 further towards the rearward position. Conversely, a smaller second diameter D2 can be achieved by moving the control member 25 further towards the forward position. The visual indicator 24A can be used to identify the instantaneous second diameter D2 of the expandable portion 32. Alternatively (or in addition), the struts 34A and 34B may be biased in the opened position so as to automatically expand outwardly to the second diameter D2 when the protective sheath 42 is slid back from the expandable portion 32. As such, sliding movement of the protective sheath 42 relative to the struts 34A and 34B can be used to selectively control the second diameter D2. In this configuration, the inner sleeve 40 and the movable components of the handle assembly 20 may not be necessary.

[0044] When the catheter device 10 is in the second operating mode, the expandable portion 32 can be pulled along the guide wire 52 through the narrowed region of the blood vessel 50. This can be accomplished by pulling on the handle assembly 20. In doing so, the incising elements 36 engage the atherosclerotic material 54 and create longitudinal incisions 56 therein. As shown in Figs. 6 and 7, the outer surface area of the arcuate shaped struts 34A and 34B, which is adjacent to the

incising element 36s, is configured to ride along a surface of the atherosclerotic material 54, thereby limiting the depth of the incisions 56 and preventing the incising members 36 from cutting the walls of the blood vessel 50. The expandable portion 32 can be moved any distance along the guide wire 52 to create incisions 56 having any desired length. After the incisions 56 are made in the atherosclerotic material 54, the catheter device 10 can be returned to the first operating mode (shown in Figs. 1 through 4) by moving the control member 25 to the forward position. In doing so, the expandable portion 32 returns to the closed position. The protective sheath 42 can be slid over the expandable portion 32 and the catheter tube 30 may be removed from the blood vessel 50.

[0045] Alternatively, the catheter device 10 can be used to create additional incisions 56 in the atherosclerotic material 54. For example, after the catheter device 10 has been returned to the first operating mode, the expandable portion 32 can be relocated within the narrowed region of the blood vessel 50. The catheter tube 30 can then be rotated within the blood vessel 50 by rotating the handle assembly 20 so as to align the incising elements 36 with other portions of the atherosclerotic material 54. The previous steps can then be repeated any number of times to make multiple passes through the narrowed region of the blood vessel 50 and create additional incisions in the atherosclerotic material 54.

[0046] Thus, it should be appreciated that the illustrated catheter device 10 is advantageous in many respects. In one example, the second diameter D2 of the expandable portion 32 can be selectively controlled by operation of the handle assembly 20 or by sliding movement of the protective sheath 42. This enables the catheter device 10 to be adapted for use in blood vessels 50 of different sizes or varying diameters. In another example, the illustrated catheter device 10 can apply varying magnitudes of radial forces to the atherosclerotic material 54 by controlling the amount of force being applied to the control member 25 on the handle assembly 20. This enables the catheter device 10 to generate sufficient radial force to create incisions 56 in atherosclerotic material 54 while reducing the potential for tearing the walls of the blood vessel 50. In yet another example, the catheter device 10 can be

used to make any number of passes during a single procedure to make multiple incisions 56 in atherosclerotic material 54 of varying lengths and shapes.

[0047] Referring now to Figs. 8 through 10, there is illustrated a catheter tube 130 having an expandable portion 132, in accordance with a second embodiment of this invention. The catheter tube 130 and the expandable portion 132 may include any structural features as described and illustrated above in the previous embodiment, although such is not required. Similar features have been numbered with common reference numerals but have been increased by 100 (i.e., 110, 120, 130, etc.). It should be appreciated that similar features are structured similarly, operate similarly, and/or have the same function unless otherwise indicated by the drawings or this specification.

[0048] For example, the catheter tube 130 may extend from a handle assembly (not shown) as described above in the first embodiment. The expandable portion 132 is provided on a distal end of the catheter tube 130 and may include a tip member 138. The catheter tube 130 may also include an inner sleeve 140 and a protective sheath (not shown), which is also described above in the first embodiment.

[0049] In the illustrated embodiment, however, the expandable portion 132 includes four struts 134A, 134B, 134C, and 134D that are respectively separated by four longitudinally extending slits 135A, 135B, 135C, and 135D. The illustrated struts 134A, 134B, 134C, and 134D each include an incising element 136, although such is not required. It should be appreciated that the expandable portion 132 may have any number or configuration of struts and incising elements as desired.

[0050] As shown in Fig. 8, the illustrated expandable portion 132 further includes recessed portions 160 that respectively extend into the outer surfaces of the struts 134A, 134B, 134C, and 134D. For example, the struts 134A, 134B, 134C, and 134D can be slightly bowed inwardly toward the inner sleeve 140 when in the closed position or, alternatively, may have a reduced thickness along a central portion thereof to create the recessed portions 160. The illustrated incising elements 136 are respectively disposed within the recessed portions 160. Thus, when the catheter tube 130 is inserted into a blood vessel, as described above, the recessed portions 160 help

to prevent the incising elements 136 from coming into contact with inner walls of the blood vessel. On the other hand, when the expandable portion 132 is expanded to an opened position, as explained below, the incising elements 136 become exposed from the recessed portions 160. It should be appreciated that the recessed portions 160 can eliminate or reduce the need for the protective sheath (not shown).

[0051] The expandable portion 132 can be operated between a closed position (shown in Fig. 8) and an opened position (shown in Figs. 9 and 10) by selective movement of the inner sleeve 140 relative to the catheter tube 130, as described above in the first embodiment. Alternatively (or in addition), the struts 134A, 134B, 134C, and 134D can be biased in the opened position. In such an embodiment, the protective sheath (not shown) can be used to effect movement of the expandable portion 132 between the closed position and the opened position.

[0052] Referring now to Figs. 11 through 13, there is illustrated a catheter tube 230 having an expandable portion 232, in accordance with a third embodiment of this invention. The catheter tube 230 and the expandable portion 232 may include any structural features as described and illustrated above in the previous embodiments, although such is not required. Similar features have been numbered with common reference numerals but have been increased by 200 (i.e., 210, 220, 230, etc.). It should be appreciated that similar features are structured similarly, operate similarly, and/or have the same function unless otherwise indicated by the drawings or this specification.

[0053] For example, the catheter tube 230 may extend from a handle assembly (not shown) as described above in the first embodiment. The expandable portion 232 is provided on a distal end of the catheter tube 230 and includes a pair of struts 234A and 234B that are separated by a pair of longitudinally extending slits 235A and 235B. The catheter tube 230 may also include a tip member 238, an inner sleeve 240, and a protective sheath (not shown), which is described above in the first embodiment.

[0054] In the illustrated embodiment, however, the expandable portion 232 includes a first pair of weakened regions 237A, 237B and a second pair of weakened regions 239A, 239B that are respectively located at opposite ends of the struts 234A

and 234B. The illustrated weakened regions 237A, 237B and 239A, 239B are formed by enlarged apertures that extend through side walls of the expandable portion 232 that function as hinges. The weakened regions 237A, 237B and 239A, 239B may help reduce the amount of bending stress in the side walls of the expandable portion 232 when the struts 234A and 234B are moved to an opened position. The struts 234A and 234B may include any number or configuration of weakened regions. Further, it should be appreciated that any of the other embodiments in this disclosure may also include weakened regions 237A, 237B and 239A, 239B.

[0055] The illustrated struts 234A and 234B remain generally flat along respective lengths thereof in both a closed position (shown in Fig. 11) and an opened position (shown in Figs. 12 and 13) so as to form an apex, although such a configuration is not required. The incising elements 236 are provided along the generally flat portion of the respective struts 234A and 234B. As such, the incising elements 236 may also function as stiffening members for increasing the strength of the struts 234A and 234B. Further, this configuration can reduce the amount of stress in the connection between the incising elements 236 and the struts 234A and 234B, which may otherwise be caused by bowing of the struts 234A and 234B.

[0056] As shown in Fig. 12, end portions of the incising elements 236 may extend beyond the apex that is formed by each of the respective struts 234A and 234B. This configuration can increase the effective blade height of the incising elements 236 when the expandable portion 232 is in the opened position. As such, the incising elements 236 may have a reduced blade height when the expandable portion 232 is in the closed position, which may eliminate the need for the protective sheath (not shown).

[0057] The expandable portion 232 can be operated between the closed position and the opened position by selective movement of the inner sleeve 240 relative to the catheter tube 230, as described above in the first embodiment. Alternatively (or in addition), the struts 234A and 234B can be biased in the opened position. In such an embodiment, the protective sheath (not shown) can be used to effect movement of the expandable portion 232 between the closed position and the opened position.

[0058] Referring now to Figs. 14 through 16, there is illustrated a catheter tube 330 having an expandable portion 332, in accordance with a fourth embodiment of this invention. The catheter tube 330 and the expandable portion 332 may include any structural features as described and illustrated above in the previous embodiments, although such is not required. Similar features have been numbered with common reference numerals but have been increased by 300 (i.e., 310, 320, 330, etc.). It should be appreciated that similar features are structured similarly, operate similarly, and/or have the same function unless otherwise indicated by the drawings or this specification.

[0059] For example, the catheter tube 330 may extend from a handle assembly (not shown) as described above in the first embodiment. The expandable portion 332 is provided on a distal end of the catheter tube 330 and may include a tip member 338. The catheter tube 330 may also include an inner sleeve 340 that is attached to the tip member 338 and a protective sheath (not shown), which is also described above in the first embodiment.

[0060] In the illustrated embodiment, however, the expandable portion 332 includes a pair of struts 334A and 334B that are supported thereon in a cantilevered manner (i.e., not attached to one another or to the tip member 338 at their distal ends), the purpose of which will be explained below. The struts 334A and 334B are separated by a pair of longitudinally extending slits 335A and 335B that extend from the end of the expandable portion 332. A pair of incising elements 336 is respectively provided along outer surfaces of the struts 334A and 334B. It should be appreciated, however, that the expandable portion 332 may have any number or configuration of struts and incising elements as desired.

[0061] As shown in Figs. 15 and 16, the illustrated struts 334A and 334B are supported on the expandable portion 332 so that they can be splayed open in a Y-shaped configuration. For example, the struts 334A and 334B can be splayed open by drawing the inner sleeve 340 within the catheter tube 330, as described above in the first embodiment. In doing so, the tip member 338 slides along the inner surfaces of the struts 334A and 334B and pivots them outwardly. Alternatively (or in

addition), the struts 334A and 334B can be biased in the splayed open position. In such an embodiment, the protective sheath (not shown) can be used to effect movement of the expandable portion 332 between a closed position and the splayed open position.

[0062] The struts 334A and 334B remain generally flat along their respective lengths in both a closed position (shown in Fig. 14) and the splayed open position, although such is not required. As such, the incising elements 336 may also function as stiffening members for increasing the strength of the struts 334A and 334B. Further, this configuration can reduce the amount of stress in the connection between the incising elements 336 and the struts 334A and 334B, which may otherwise be caused by bowing of the struts 334A and 334B.

[0063] As shown in Fig. 15, end portions of the incising elements 336 may extend beyond the distal ends of the respective struts 334A and 334B. This configuration can increase the effective blade height of the incising elements 336 when the expandable portion 332 is in the splayed open position. As such, the incising elements 336 may have a reduced blade height when the expandable portion 332 is in the close position, which may eliminate the need for the protective sheath (not shown).

[0064] The principle and mode of operation of this invention have been explained and illustrated in its preferred embodiments. However, it must be understood that this invention may be practiced otherwise than as specifically explained and illustrated without departing from its spirit or scope.

What is claimed is:

1. An intravascular catheter device comprising:
a catheter tube including an expandable portion having a plurality of struts each defining an outer surface, the expandable portion being operable between a closed position, wherein the expandable portion has a first diameter, and an opened position, wherein the expandable portion has a second diameter that is larger than the first diameter; and
an incising element provided on the outer surface of at least one of the struts, the incising element having a blade that extends outwardly in a radial direction from the outer surface of the strut for creating an incision in atherosclerotic material located within a blood vessel when the expandable portion is in the opened position.
2. The intravascular catheter device of Claim 1, wherein the blade of the incising element extends parallel with a longitudinal axis of the expandable portion.
3. The intravascular catheter device of Claim 1, wherein the struts are respectively attached to one another at their opposite ends and bow outwardly in the opened position.
4. The intravascular catheter device of Claim 3, wherein the outer surface of each strut defines an arcuate member having a surface area adjacent the incising member that limits the depth of an incision created by the incising member and prevents the incising member from cutting a wall of the blood vessel.
5. The intravascular catheter device of Claim 3 further including an inner sleeve that is supported for sliding movement within the catheter tube, the inner sleeve being connected to a distal end of the expandable portion for selectively controlling movement of the struts between the closed position and the opened position.

6. The intravascular catheter device of Claim 5, wherein the catheter tube extends from a handle assembly and the inner sleeve is connected to a control member that is movably supported on the handle assembly for selectively controlling movement of the expandable portion between the closed position and the opened position.

7. The intravascular catheter device of Claim 6, wherein the handle assembly includes an indicator that identifies the relative position of the control member on the handle assembly.

8. The intravascular catheter device of Claim 6, wherein the handle assembly includes a locking mechanism for securing the control member in a selected position on the handle assembly.

9. The intravascular catheter device of Claim 3, wherein the expandable portion defines weakened regions that are respectively located at opposite ends of each strut and adapted to function as hinges.

10. The intravascular catheter device of Claim 3, wherein a portion of each strut remains generally flat along a length thereof in both the closed position and the opened position, and the incising element is supported on the flat portion of at least one strut.

11. The intravascular catheter device of Claim 3, wherein the struts are biased in the opened position.

12. The intravascular catheter device of Claim 11 further including a protective sheath that is supported for sliding movement along an outer surface of the catheter tube to control movement of the expandable portion between the closed position and the opened position.

13. The intravascular catheter device of Claim 1, wherein the struts are supported in a cantilevered fashion on the expandable portion so as to be splayed open when in the opened position.

14. The intravascular catheter device of Claim 13 further including a tip member that is supported for sliding movement along inner surfaces of the struts so as to pivot the struts between the closed position and the opened position.

15. The intravascular catheter device of Claim 14, wherein the tip member is attached to an inner sleeve that is supported for sliding movement within the catheter tube.

16. The intravascular catheter device of Claim 15, wherein the catheter tube extends from a handle assembly and the inner sleeve is connected to a control member that is movably supported on the handle assembly for selectively controlling movement of the expandable portion between the closed position and the opened position.

17. The intravascular catheter device of Claim 16, wherein the handle assembly includes an indicator that identifies the relative position of the control member on the handle assembly.

18. The intravascular catheter device of Claim 13, wherein the struts are biased in the opened position.

19. The intravascular catheter device of Claim 18 further including a protective sheath that is supported for sliding movement along an outer surface of the catheter tube to control movement of the expandable portion between the closed position and the opened position.

20. An intravascular catheter device comprising:

a handle assembly including a control member that is movably supported thereon;

a catheter tube extending from the handle assembly and including an expandable portion defining a longitudinal axis and having a plurality of struts each defining an outer surface, the expandable portion being operable between a closed position, wherein the expandable portion has a first diameter, and an opened position, wherein the expandable portion has a second diameter that is larger than the first diameter;

an incising element provided on the outer surface of at least one of the struts, the incising element having a blade that extends parallel with the longitudinal axis of the expandable portion and outwardly in a radial direction therefrom; and

an inner sleeve that is supported for sliding movement within the catheter tube, the inner sleeve is connected between the control member on the handle assembly and a distal end of the expandable portion for selectively controlling movement of the expandable portion between the closed position and the opened position.

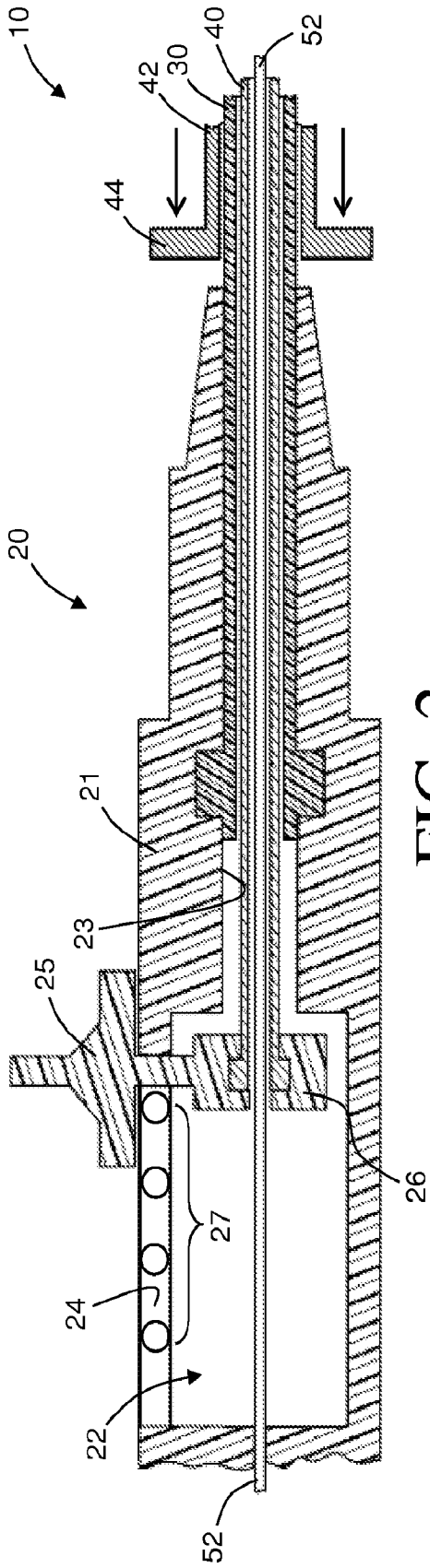

FIG. 2

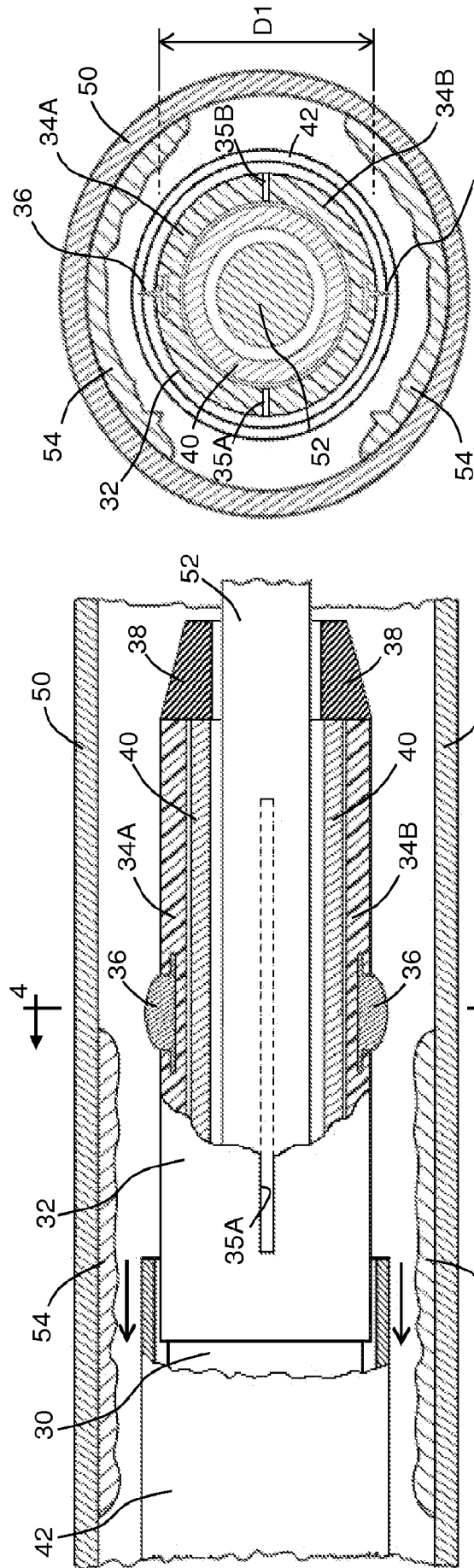

FIG. 4

FIG. 3

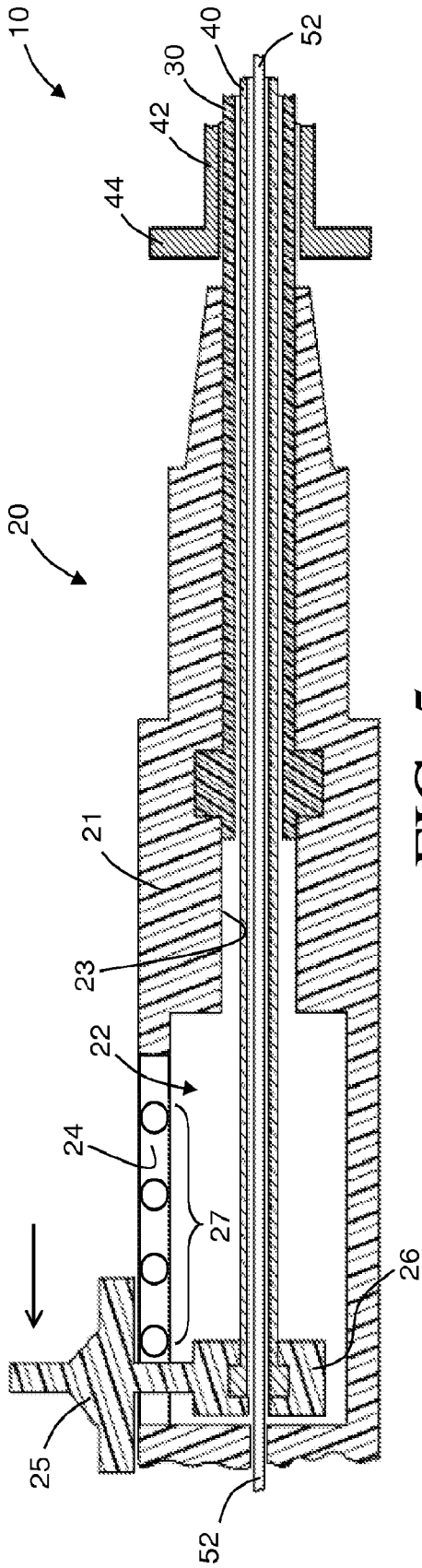

FIG. 5

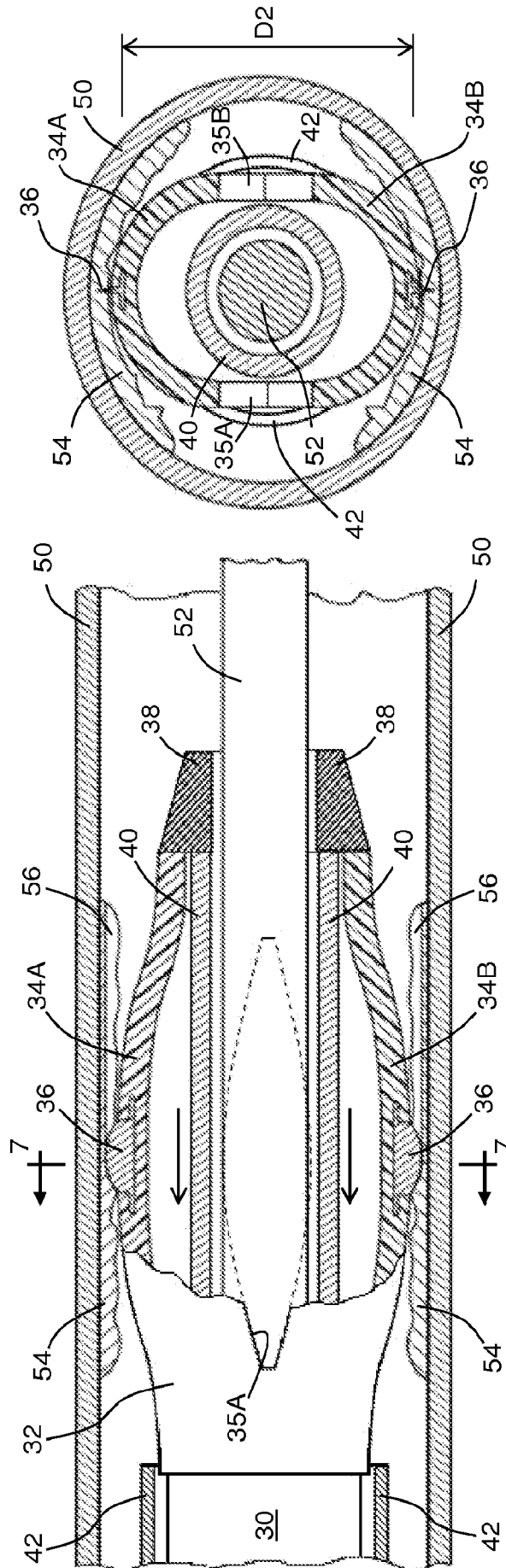

FIG. 7

FIG. 6

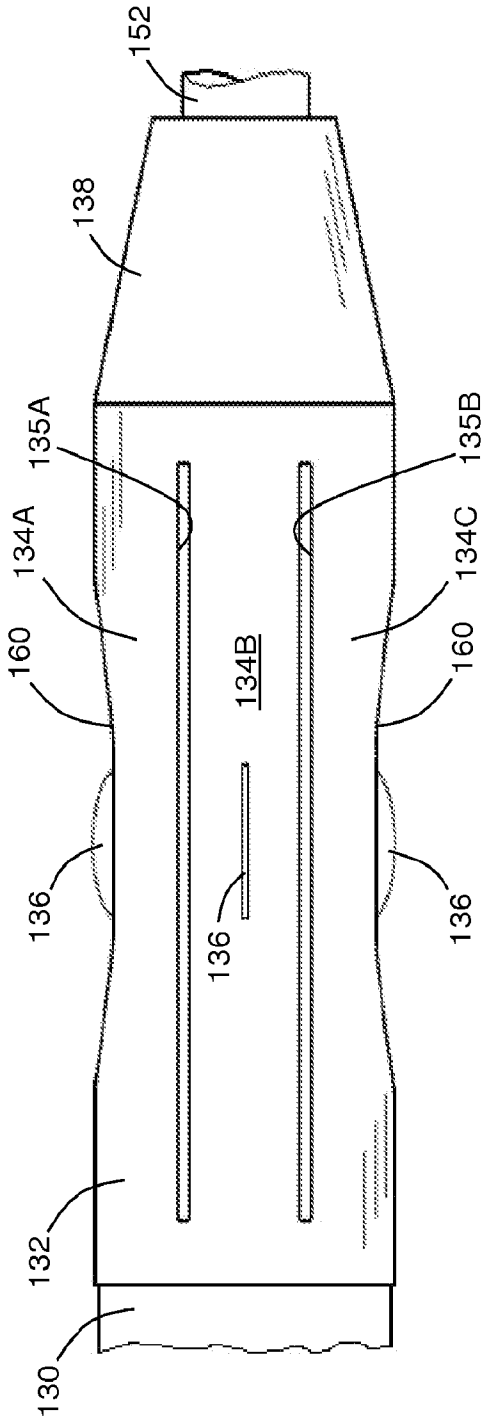

FIG. 8

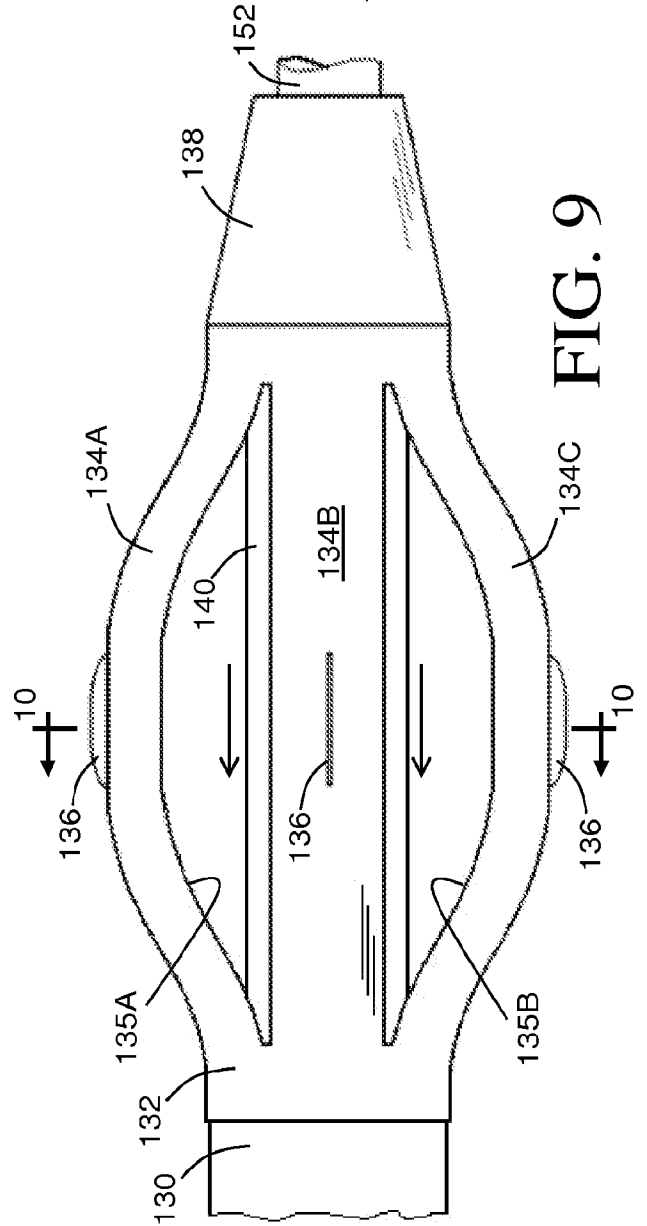

FIG. 9

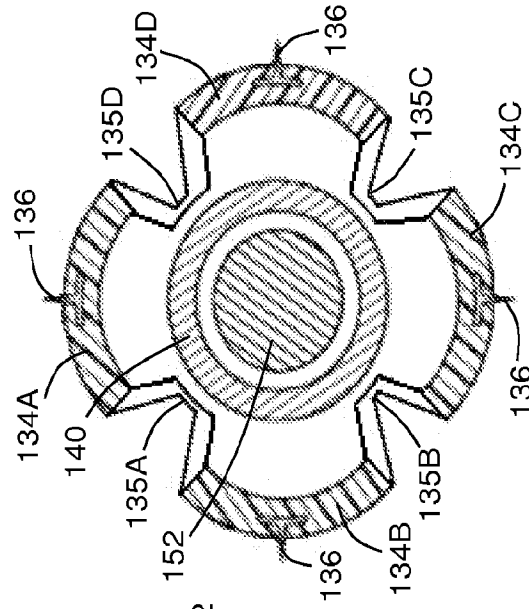

FIG. 10

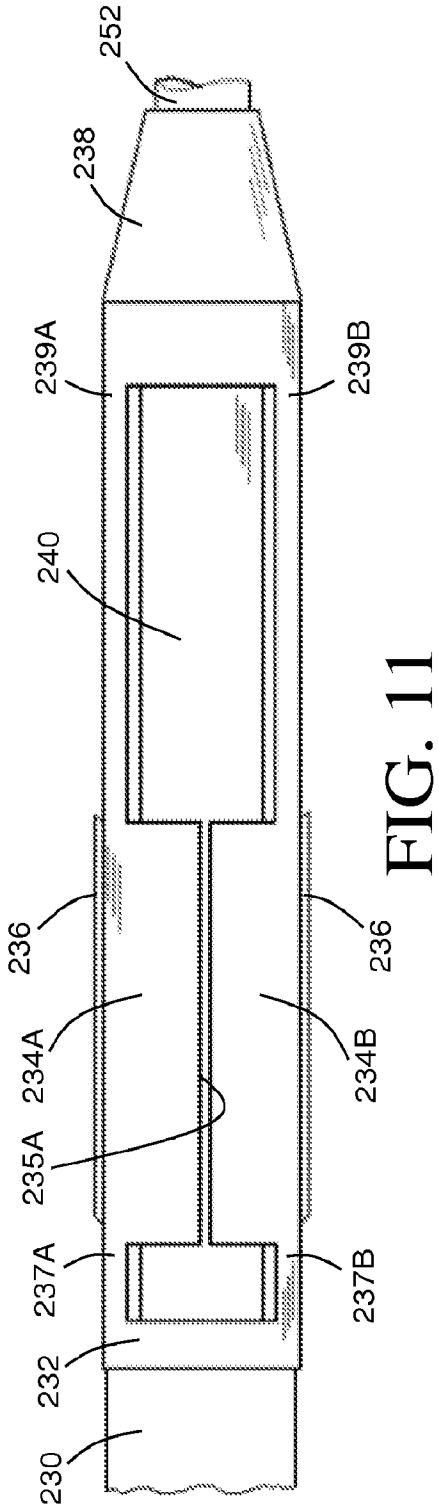

FIG. 11

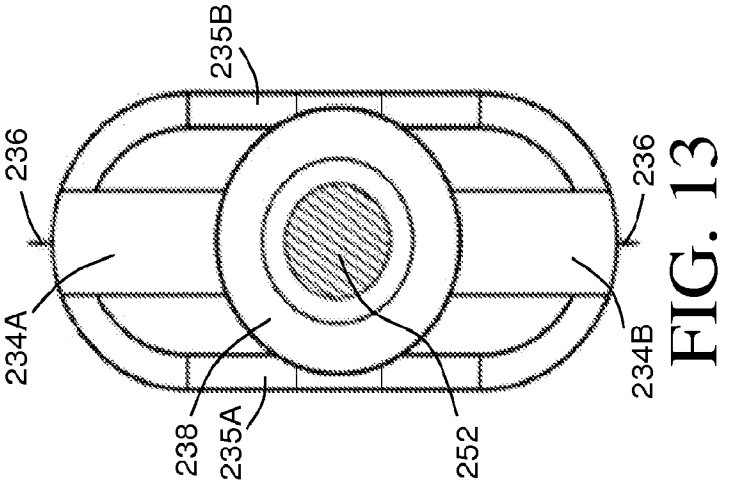

FIG. 13

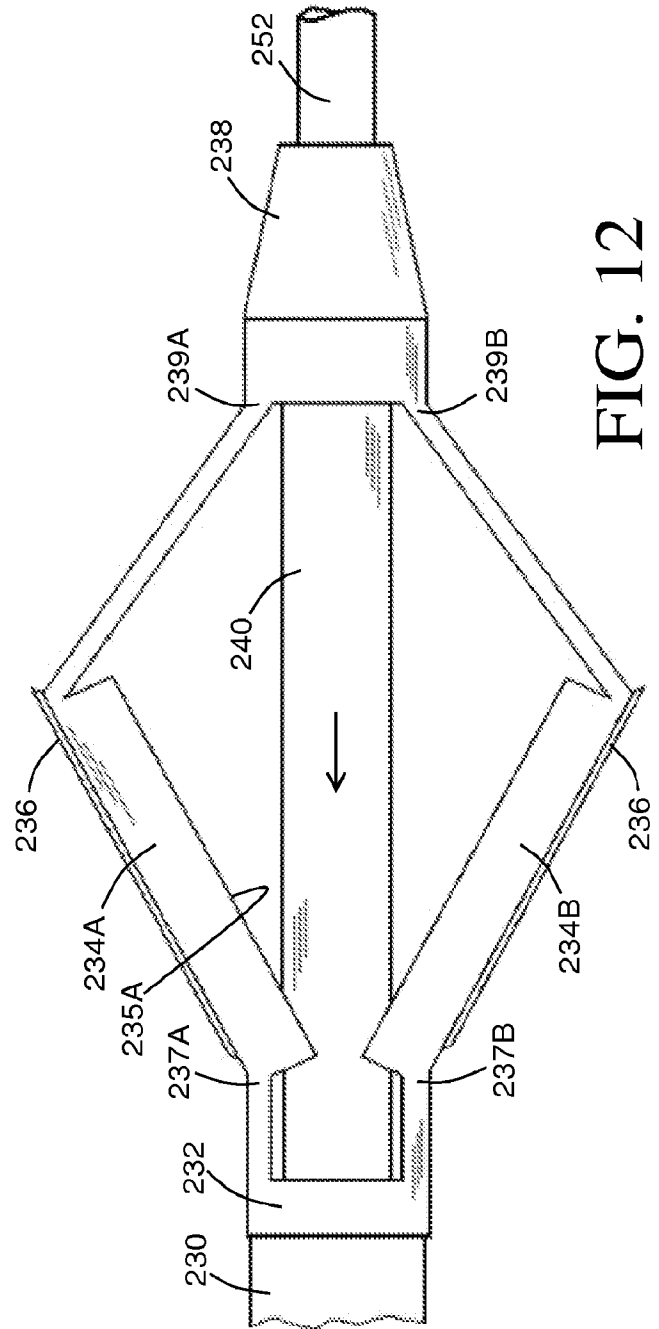
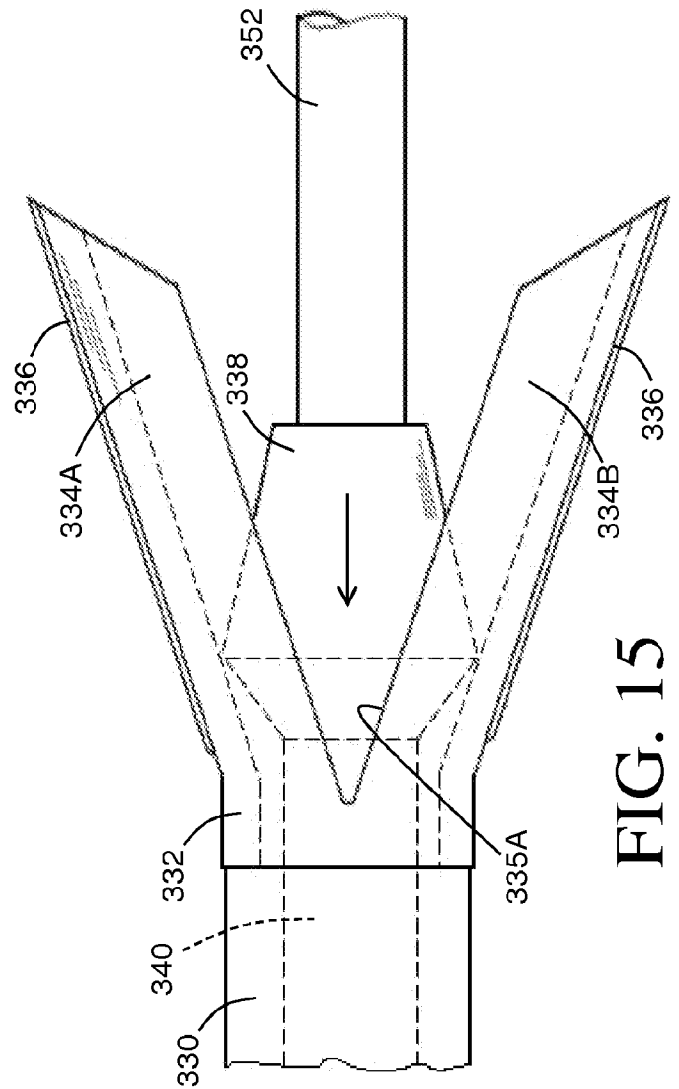
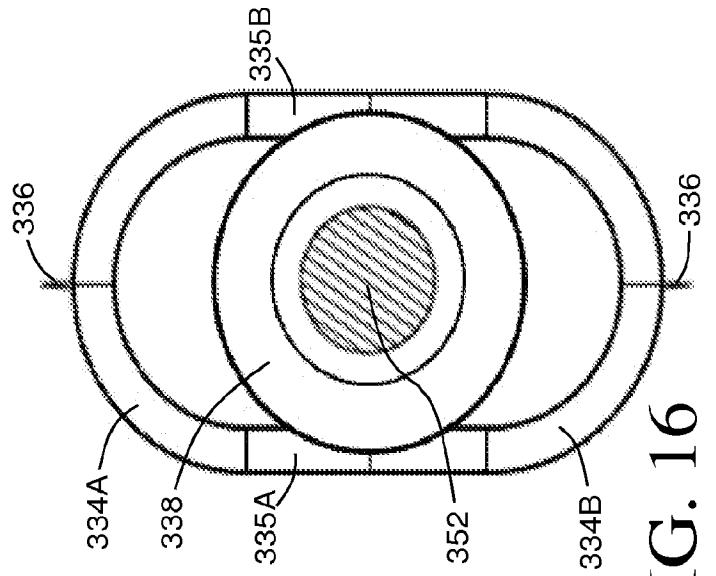
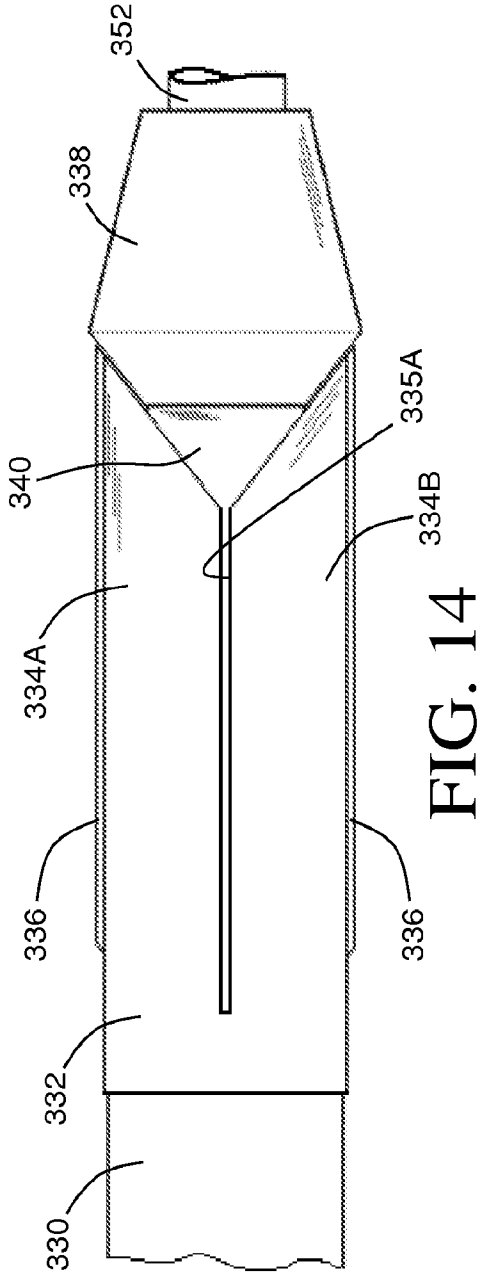

FIG. 12



A. CLASSIFICATION OF SUBJECT MATTER*A61M 25/06(2006.01)i, A61M 29/02(2006.01)i, A61B 17/22(2006.01)i*

According to International Patent Classification (IPC) or to both national classification and IPC

B. FIELDS SEARCHED

Minimum documentation searched (classification system followed by classification symbols)

A61M 25/06; A61B 18/14; A61B 17/22

Documentation searched other than minimum documentation to the extent that such documents are included in the fields searched

Korean utility models and applications for utility models

Japanese utility models and applications for utility models

Electronic data base consulted during the international search (name of data base and, where practicable, search terms used)

eKOMPASS(KIPO internal) & Keywords: catheter, expandable, incising element

C. DOCUMENTS CONSIDERED TO BE RELEVANT

Category*	Citation of document, with indication, where appropriate, of the relevant passages	Relevant to claim No.
Y A	US 7850685 B2 (CHRISTOPHER G. KUNIS et al.) 14 December 2010. See claim 1; column 10, lines 3-22, lines 31-36; column 12, lines 54-61; column 26, lines 16-27; and figures 1, 4.	1-3, 5, 6, 8, 12-16, 19 ,20 4, 7, 9-11, 17, 18
Y A	US 2010-0010521 A1 (MICHAEL R. KURRUS) 14 January 2010. See claims 1-3; paragraphs [0021], [0024], [0039]; and figures 2, 6.	1-3, 5, 6, 8, 12-16, 19 ,20
A	US 2010-0168737 A1 (DEBBY ESTHER GRUNEWALD) 01 July 2010. See the entire document.	1-20
A	US 2005-0240176 A1 (HAKAN ORAL et al.) 27 October 2005. See the entire document.	1-20
A	US 2006-0089637 A1 (RANDELL L. WERNETH et al.) 27 April 2006. See the entire document.	1-20

 Further documents are listed in the continuation of Box C. See patent family annex.

* Special categories of cited documents:

"A" document defining the general state of the art which is not considered to be of particular relevance

"E" earlier application or patent but published on or after the international filing date

"L" document which may throw doubts on priority claim(s) or which is cited to establish the publication date of citation or other special reason (as specified)

"O" document referring to an oral disclosure, use, exhibition or other means

"P" document published prior to the international filing date but later than the priority date claimed

"T" later document published after the international filing date or priority date and not in conflict with the application but cited to understand the principle or theory underlying the invention

"X" document of particular relevance; the claimed invention cannot be considered novel or cannot be considered to involve an inventive step when the document is taken alone

"Y" document of particular relevance; the claimed invention cannot be considered to involve an inventive step when the document is combined with one or more other such documents, such combination being obvious to a person skilled in the art

"&" document member of the same patent family

Date of the actual completion of the international search

31 JANUARY 2013 (31.01.2013)

Date of mailing of the international search report

31 JANUARY 2013 (31.01.2013)

Name and mailing address of the ISA/KR



Facsimile No. 82-42-472-7140

Authorized officer

CHANG, Bong Ho

Telephone No. 82-42-481-3353



INTERNATIONAL SEARCH REPORT

Information on patent family members

International application No.

PCT/US2012/055079

Patent document cited in search report	Publication date	Patent family member(s)	Publication date
US 7850685 B2	14.12.2010	AU 2006-262447 A1	04.01.2007
		CA 2612679 A1	04.01.2007
		CN 101309651 A	19.11.2008
		CN 101309651 B	07.12.2011
		EP 1895927 A2	12.03.2008
		EP 1895927 A4	09.03.2011
		IL 188882 D0	13.04.2008
		JP 2009-500052 A	08.01.2009
		US 2007-0083194 A1	12.04.2007
		US 2011-0106074 A1	05.05.2011
		US 8337492 B2	25.12.2012
		WO 2007-001981 A2	04.01.2007
		WO 2007-001981 A3	05.04.2007
		US 2010-0010521 A1	14.01.2010
US 2010-0168737 A1	01.07.2010	AU 2009-251154 A1	15.07.2010
		CA 2688972 A1	30.06.2010
		CN 101797181 A	11.08.2010
		EP 2204135 A2	07.07.2010
		EP 2204135 A3	01.09.2010
		EP 2335633 A2	22.06.2011
		EP 2335633 A3	28.12.2011
		JP 2010-155082 A	15.07.2010
US 2005-0240176 A1	27.10.2005	AT 514389 T	15.07.2011
		AU 2003-286717 A1	13.05.2004
		AU 2003-286717 B2	22.10.2009
		AU 2005-254070 A1	29.12.2005
		CA 2512216 A1	06.05.2004
		CA 2570207 A1	29.12.2005
		EP 1572019 A2	14.09.2005
		EP 1572019 A4	17.05.2006
		EP 1572019 B1	29.06.2011
		EP 1781199 A1	09.05.2007
		JP 04473131 B2	02.06.2010
		JP 2006-503660 A	02.02.2006
		JP 2008-502427 A	31.01.2008
		US 2004-0082947 A1	29.04.2004
		US 2005-0033137 A1	10.02.2005
		US 2005-0251132 A1	10.11.2005
		US 2007-0106293 A1	10.05.2007
		US 2008-0161803 A1	03.07.2008
		US 2011-257648 A1	20.10.2011
		US 7857808 B2	28.12.2010
US 7993333 B2	09.08.2011		
WO 2004-037072 A2	06.05.2004		
WO 2004-037072 A3	26.08.2004		
WO 2005-122939 A1	29.12.2005		

INTERNATIONAL SEARCH REPORT

Information on patent family members

International application No.

PCT/US2012/055079

Patent document cited in search report	Publication date	Patent family member(s)	Publication date
US 2006-0089637 A1	27.04.2006	AU 2005-295471 A1	27.04.2006
		CA 2584016 A1	27.04.2006
		EP 1814482 A2	08.08.2007
		EP 1814482 A4	25.03.2009
		US 2009-030411 A1	29.01.2009
		WO 2006-044794 A2	27.04.2006
		WO 2006-044794 A3	02.11.2006